



# HEAVY-DUTY 11.0 AMP ORBITAL SUPER SAWZALL® KIT

## ORBITAL ACTION



6521-21



**FASTEST CUTTING  
POWERFUL 11.0 AMPS  
0-3200 SPM!**

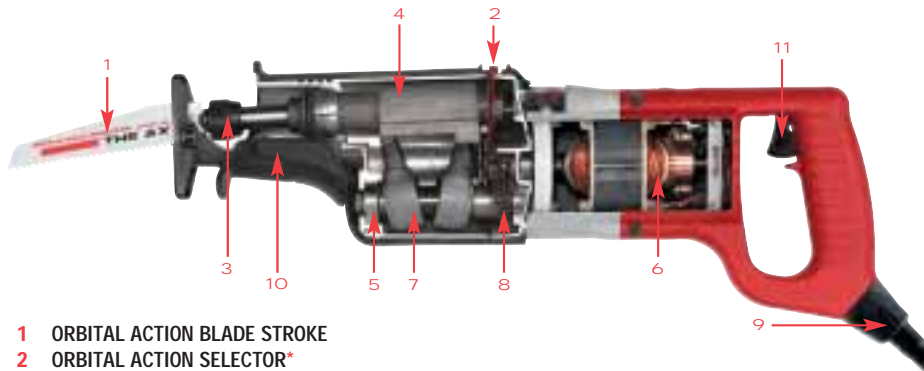

- 1 ORBITAL ACTION BLADE STROKE
- 2 ORBITAL ACTION SELECTOR\*
- 3 HEAVY-DUTY STEEL QUIK-LOK™ BLADE CLAMP™ SYSTEM\*
- 4 SMOOTH COUNTER-BALANCED MECHANISM\*
- 5 PRECISION BALL AND ROLLER BEARINGS
- 6 POWERFUL 11 AMP, 3,200 SPM MILWAUKEE-BUILT MOTOR
- 7 HEAVY-DUTY STEEL DOUBLE WOBBLE PLATE MECHANISM\*
- 8 GEAR PROTECTING CLUTCH\*
- 9 QUIK-LOK® CORD
- 10 NEW KEYLESS ADJUSTABLE SHOE\*
- 11 VARIABLE SPEED SWITCH



■ **Orbital Action Selector\***  
Allows the user to set the degree of orbital action.



■ **Heavy-Duty Steel Quik-Lok™ Blade Clamp System\***

- Fast easy blade changes with no hex key to lose.
- Blades may be clamped upside down.
- Accepts standard 1/2" shank Sawzall blades.
- Return spring\* forces spindle outward so blade clamp is accessible.

■ **Gear Protecting Clutch\***



Unique gear clutch absorbs high impact forces caused by sudden blade lock-ups. Extends life of tool in extreme cutting applications.

■ **Counter Balance Mechanism\***



Anti-Vibration System. Smoothest operating, most vibration free saw in the world.

■ **1-1/4" Blade Stroke & Orbital Blade Stroke**  
For fastest cutting in thick materials.

■ **Heavy-Duty Double Bearing Wobble Plate Mechanism\* For Extra Long Life**

■ **Powerful Milwaukee Built Motor**

■ **Orbital Action Selector\***  
Allows the user to set the degree of orbital versus straight reciprocating action.

■ **Trigger Speed Control**

■ **Dial Speed Selector Switch\***  
Matches the correct speed with application for improved control.



■ **Shoe Release Lever\***  
Adjusts shoe without use of tools. Allows more efficient use of blade and depth-of-cut control.

■ **Pivot Shoe\* For Maximum Support Against Work Surface**

■ **Reversible Blade Mounting for Flush Cuts**

■ **Rubber Boot For Superior Gripping and Operator Comfort**

■ **All Ball And Roller Bearings**

■ **Quik-Lok® Cord**  
Instant field repair and safe replacement. Tool comes with 2-wire, 10'-16 gauge construction cord No. 48-76-5010. A 25' cord No. 48-76-5025 is also available.

\*Patented

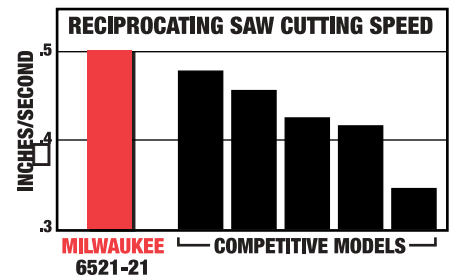

Source: Professional Service Industries, Inc.  
Note: Speed of cut in 1-1/8" particle board – 3 sheets clamped together

## SPECIFICATIONS

CATALOG NUMBER	VOLTS AC ONLY	AMPS	STROKES PER MINUTE	STEEL QUIK-LOK BLADE CLAMP	IMPACT PROTECTION	LENGTH OF STROKE	OVERALL LENGTH	NET WGT. LBS.	SHIP. WGT. LBS.
6521-21	120	11.0	0-3200	YES	YES	1-1/4"	18-1/8"	8.9	14.5

STANDARD EQUIPMENT: FOR 6521-21 – Includes Orbital Sawzall with Heavy-Duty Steel Quik-Lok Blade Clamp, Impact Resistant Carrying Case, 10' 2-Wire Quik-Lok Cord and One Wood Cutting Sawzall Blade And One Metal Cutting Sawzall Blade.