

COFFING HOISTS

PROUDLY PRESENTS

A Concert Line





Coffing Model UJL

COFFING UJL Models are designed to meet your toughest rigging applications. Whether flying truss for lighting and sound, or moving sets and backdrops, the UJL is your rigging solution. Compact and quiet, the UJL features multiple disc motor brake, mechanical overload clutch, and chain end stop for safety.

- **CROWD PLEASER** - Rated loads from 1/2 to 2 ton, lifts to 120 feet, and speeds of 8, 16, and 32 FPM.
- **ROAD WARRIOR** - Rugged aluminum housing withstands setup and tear down show after show.
- **POWERFUL** - Dual voltage, industrial duty motors for long service. 115-volt control standard, 24 VC optional.
- **QUIET** - Five-pocket load sheave for smooth, quiet operation and reduced chain wear.
- **COOL** - Oil bath transmission runs cooler, lasts longer.
- **VERSATILE PERFORMER** - Spring-loaded contactor allows for inverted or upright lifting.
- **“NO WORRIES, MON”** - Hoist motor, electrical panel, and chaining parts are easily accessible for maintenance and repair without disassembly of transmission.
- **TOUGH ACT TO FOLLOW** - Lifetime warranty against defective workmanship and materials.
- **LOCAL GIG** - Made in USA.



Hoist Specifications

Model* Number	Rated Load (Lbs.)	Number of Chains	Max Lift (Ft.)	Lifting Speed (FPM)	Motor H.P.	Motor Voltage / Phase / Hertz**			Ship Wt. Unit Less Chain (Lbs.)	Net Wt. Unit Less Chain (Lbs.)	
							Amps	Amps			
UJL-1016-1	1000	1	120	16	1/2	115/1/60	7.6	230/1/60	3.8	73	68
UJL-1016-3	1000	1	120	16	1/2	230/3/60	1.9	460/3/60	.95	68	63
UJL-1032-1	1000	1	120	32	1	115/1/60	14.0	230/1/60	7.0	86	81
UJL-1032-3	1000	1	120	32	1	230/3/60	3.0	460/3/60	1.5	75	70
UJL-2016-1	2000	1	120	16	1	115/1/60	14.0	230/1/60	7.0	86	81
UJL-2016-3	2000	1	120	16	1	230/3/60	3.0	460/3/60	1.5	75	70
UJL-4008-1	4000	2	60	8	1	115/1/60	14.0	230/1/60	7.0	96	91
UJL-4008-3	4000	2	60	8	1	230/3/60	3.0	460/3/60	1.5	85	80

* All units are less chain and less control pendant. Specify lift, number of pigtails, and control pendant, if required.

** All motors are dual voltage. 3-phase and 1-phase motors will operate on 50 hertz power, but will only run 5/6 nominal speed. Optional 3-phase voltages — 208, 380, 415,

Lightweight • Quiet • Rugged • Portable



***We raise the house—
so you can bring it down!***

UJL Dimensional Specifications

Dimensions in Parenthesis are in Millimeters

SINGLE Chain

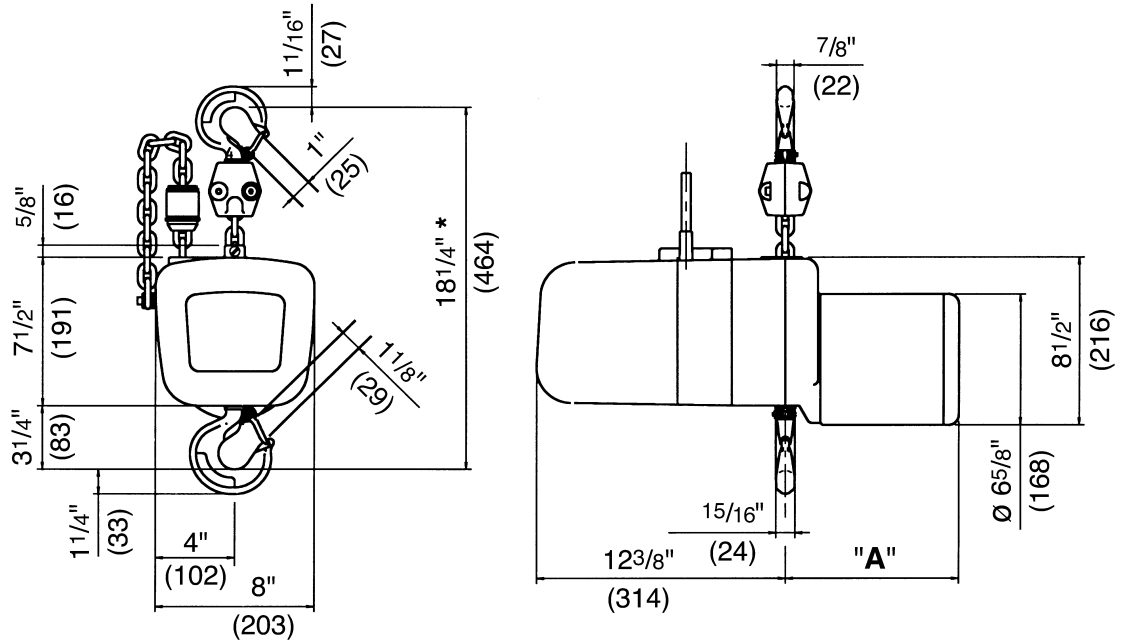

DOUBLE Chain

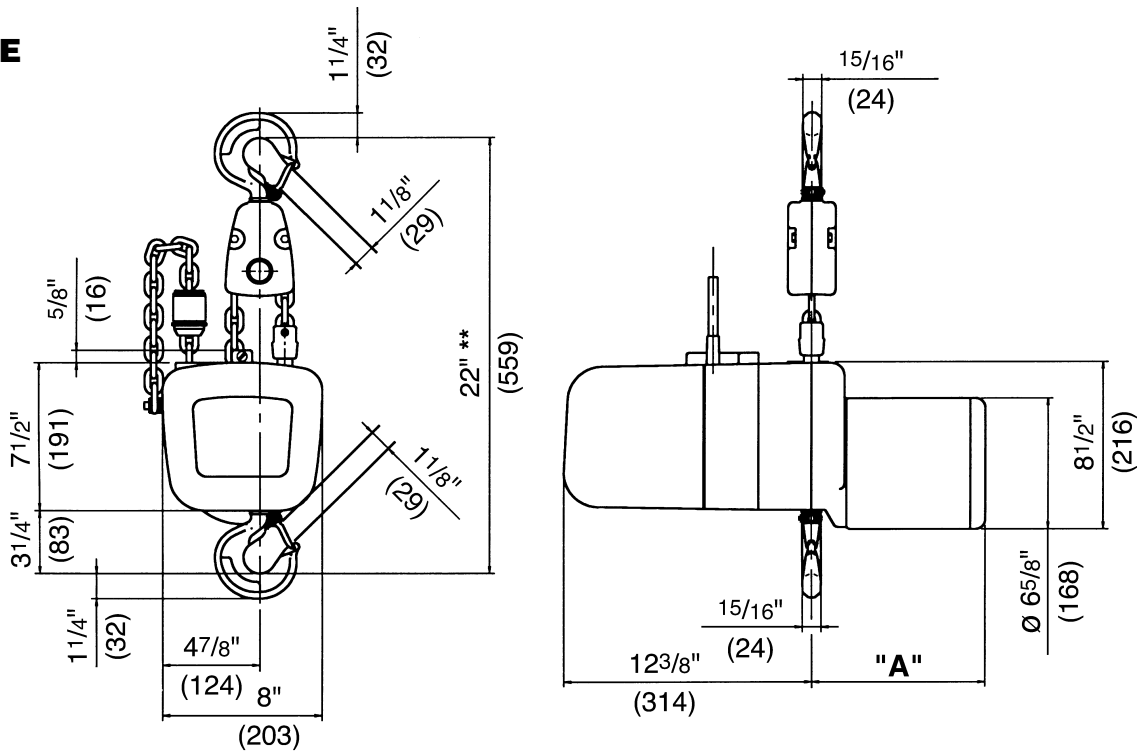

Hoist Dimensions

Model Number	Rated Load (Lbs.)	A 1-PH (In.)	A 3-PH (In.)
UJL-1016	1000	9	8 1/4
UJL-1032	1000	10 1/2	8 5/8
UJL-2016	2000	10 1/2	8 5/8
UJL-4008	4000	10 1/2	8 5/8

UJL Outstanding Features

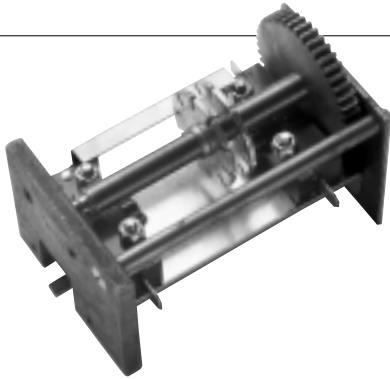

Limit Switch Assembly

Regulates upper and lower chain travel. Brass nuts standard for consistent hoist positioning. Consult factory for encoder mounting.



Five-Pocket Load Sheave

Increases chain and sheave engagement 25% over hoists with conventional four-pocket sheaves. Provides smoother lifting, less vibration, and reduces chain wear. Zinc plated chain optional.

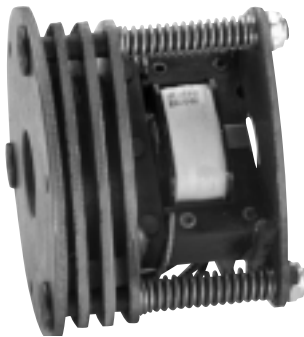

Multiple Disc Motor Brake

Heavy duty design for reliable, safe operation. Direct acting for positive load holding and spotting.



Shur-Loc[®] Hook

Available as an *option* to standard swivel hook—wider throat opening for easier rigging.



Dual Voltage Hoist Motor

Totally enclosed, non-ventilated, high torque, hoist duty rated motor with class F insulation.



Mechanical Overload Protection Device

Protects hoist, operator, and supporting structures from damaging overloads, chain jamming & reverse phasing.



Solid State Starting Switch

Standard on single phase units. Provides greater reliability and starting consistency with fewer components to wear out or fail.

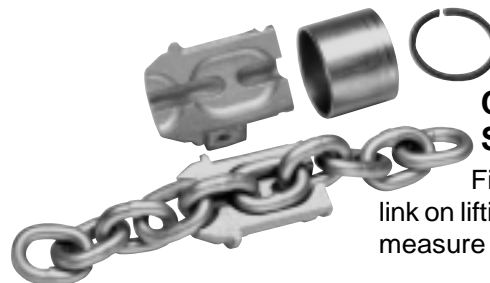

Chain End Stop Assembly

Fits below dead end link on lifting chain for added measure of safety.

ACT 2

Related Products & Accessories

ProStar models are designed and built for the unique rigging applications encountered at smaller venues. Lightweight and portable, the **ProStar** features a dual braking system and overload protection for the hoist and operator. *Take the stage with ProStar.*

- **COMPACT PACKAGE** - Aluminum housing is strong and lightweight; measuring only 12¹/₂" in length.
- **SMOOTH OPERATOR** - Heat treated alloy steel load sheave for smooth, quiet lifting.
- **VERSATILE PERFORMER** - Models range in capacities 300 lbs. to 1000 lbs. with 8 and 16 FPM lifting speeds.
- **CRANK UP THE VOLUME** - Voltages range from 115-1-60 to 460-3-50/60; and most voltages in-between.
- **TOUGH ACT TO FOLLOW** - Lifetime warranty against defective workmanship and materials.
- **LOCAL GIG** - Made in USA.

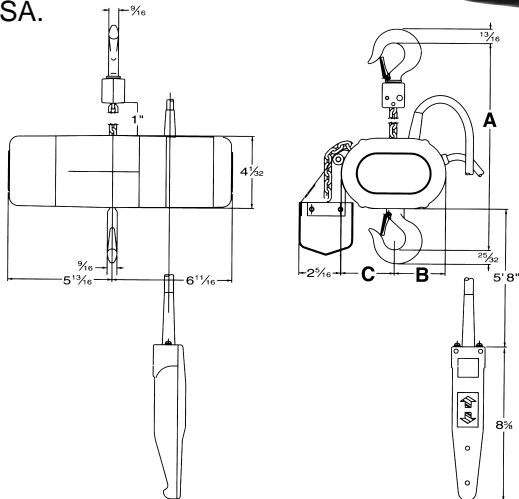
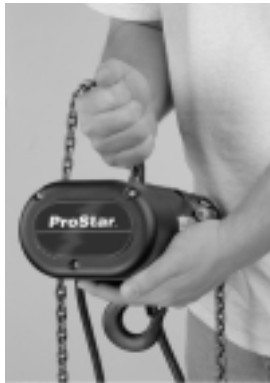

300 - 1000 Lbs.

*Made In USA
from Columbus
McKinnon
Entertainment
Division*

Reeving	A	B	C
single	11 ¹ / ₁₆	3	2 ¹⁵ / ₁₆
double	12 ¹ / ₈	3 ⁹ / ₁₆	2 ³ / ₈

All dimensions in inches

Hoist Specifications

Product Code	Capacity (Lbs.)	Voltage	Lifting Speed (FPM)	Number of Chains	Standard Lifts* (Ft.)	Motor H.P.	Approx. Shipping Wt. (Lbs.)
2049S	300	115-1-60	16	1	60	1/6	49
2041S†	300	220-1-50	16	1	60	1/6	49
2042S	300	230-1-50/60	16	1	60	1/6	49
2043S	300	380/415-3-50 440/460-3-60	16	1	60	1/6	49
2127S	500	230-3-50/60	16	1	60	1/6	49
2128S	500	380/415-3-50 440-460-3-60	16	1	60	1/6	49
2050S	600	115-1-60	8	2	60	1/6	67
2044S†	600	220-1-50	8	2	60	1/6	67
2045S	600	230-3-50/60	8	2	60	1/6	67
2046S	600	380/415-3-50 440/460-3-60	8	2	60	1/6	67
2129S	1000	230-3-50/60	8	2	60	1/6	67
2130S	1000	380/415-3-50 440/460-3-60	8	2	60	1/6	67

Chain Containers

Product Code	Max. Length of Lift		Shipping Wt. (Lb.)
	1-Chain Single (Ft.)	2-Chain Double (Ft.)	
2063	10	N/A	1
2064	20	10	1.5
2065	40	20	1.5
2066	80	40	1.5
2067	120	60	2.25

All models, contactor located in hoist body. * Base model, longer or shorter lifts available.

† Hoists are 220-1-50 single phase only - not available 220-1-60.



Beam Clamps

- **RELIABLE AND RUGGED** - All steel construction is lightweight and durable.
- **PORTABLE** - For permanent or temporary mounting.
- **ADJUSTABLE** - Fits securely on a wide range of flange widths and beam sizes.
- **SPECIAL DESIGN** - Clamp jaw design reduces flange stress by distributing load away from flange edge.
- **LOW HEADROOM** - Built-in suspension bar provides close mounting.



UJL Chain Bags

- **TOUGH** - heavy-duty, Cordura nylon construction
- **SNUG** - Close-fit design
- **ON AND OFF** - Quick mount hooks with specially engineered mounting bracket



Wire Grips

- **CAPACITIES** - 1, 2¹/₂, and 5 ton.
- **RUGGED AND PORTABLE** - All steel construction is lightweight and durable.
- **EASY TO USE** - Spring-loaded design automatically holds wire, but then releases instantly to quickly insert or remove wire.



UJL Road Case

- **CUSTOM DESIGN** - Engineered to secure and cradle 1/2, 1 or 2 ton UJL models.
- **TRUCK PACK DIMENSIONS** - 45" wide (1/2 pack) X 22¹/₂" deep (1/4 pack) X 26¹/₂" high.
- **ISOLATED COMPARTMENTS** - Accommodate hoists, load chain, chain containers, hooks, shackles, slings, beam clamps, wire grips, and other rigging gear. Fully lined, hard Etha foam in lid locks all compartments in place.
- **BUILT TO LAST** - 3/8" 7-ply birch case construction with 3/4" 13-ply birch cradle holds hoists in position. Textured surface of .05" thick, high pressure laminate for case durability. Dual interlocked corner material riveted every 5" with extra deep tongue and groove extrusion for case strength.
- **READY TO ROLL** - Full 3/4" wheel plate with high strength polyurethane casters, rated at 400 lbs. each, make loading in and out easy.
- **MADE IN USA**



Every hoist is thoroughly inspected and tested prior to shipment from the factory. Should any problem develop, return the complete hoist prepaid to your nearest Coffing Hoists Authorized Warranty Repair Station. If inspection reveals that the problem is caused by defective workmanship or material, repairs will be made without charge and the hoist will be returned, transportation prepaid. This warranty does not apply where: **(1)** deterioration is caused by normal wear, abuse, improper or inadequate power supply, eccentric or side loading, overloading, chemical or abrasive actions, improper maintenance, or excessive heat; **(2)** problems resulted from repairs, modifications, or alterations made by persons other than factory or Coffing Authorized Warranty Repair Station personnel; **(3)** the hoist has been abused or damaged as a result of an accident; **(4)** repair parts or accessories other than those supplied by Coffing Hoists are used on the hoist. Equipment and accessories not of the seller's manufacture are warranted by the manufacturer. Except as stated herein, Coffing Hoists makes no other warranties, express or implied, including warranties of merchantability and fitness for a particular purpose.

⚠ WARNING

Overloading and Improper Use Can Result In Injury

To Avoid Injury:

- Do not exceed working load limit, load rating, or capacity.
- Do not use to lift people or loads over people.
- Use only alloy chain and attachments for overhead lifting.
- Read and follow all instructions.

High Performance Lifting

COFFING[®] **HOISTS**

Country Club Road • PO Box 779 Wadesboro, NC 28170 USA

Phone: (800) 477-5003 (704) 694-2156

FAX: (800) 374-6853 (704) 694-6829

www.coffinghoists.com • e-mail: coffing@cmworks.com