

# Dimensional DataBook

*Dimensional Information  
Little Mule Products  
Publications LMC-2 and LMU-3*

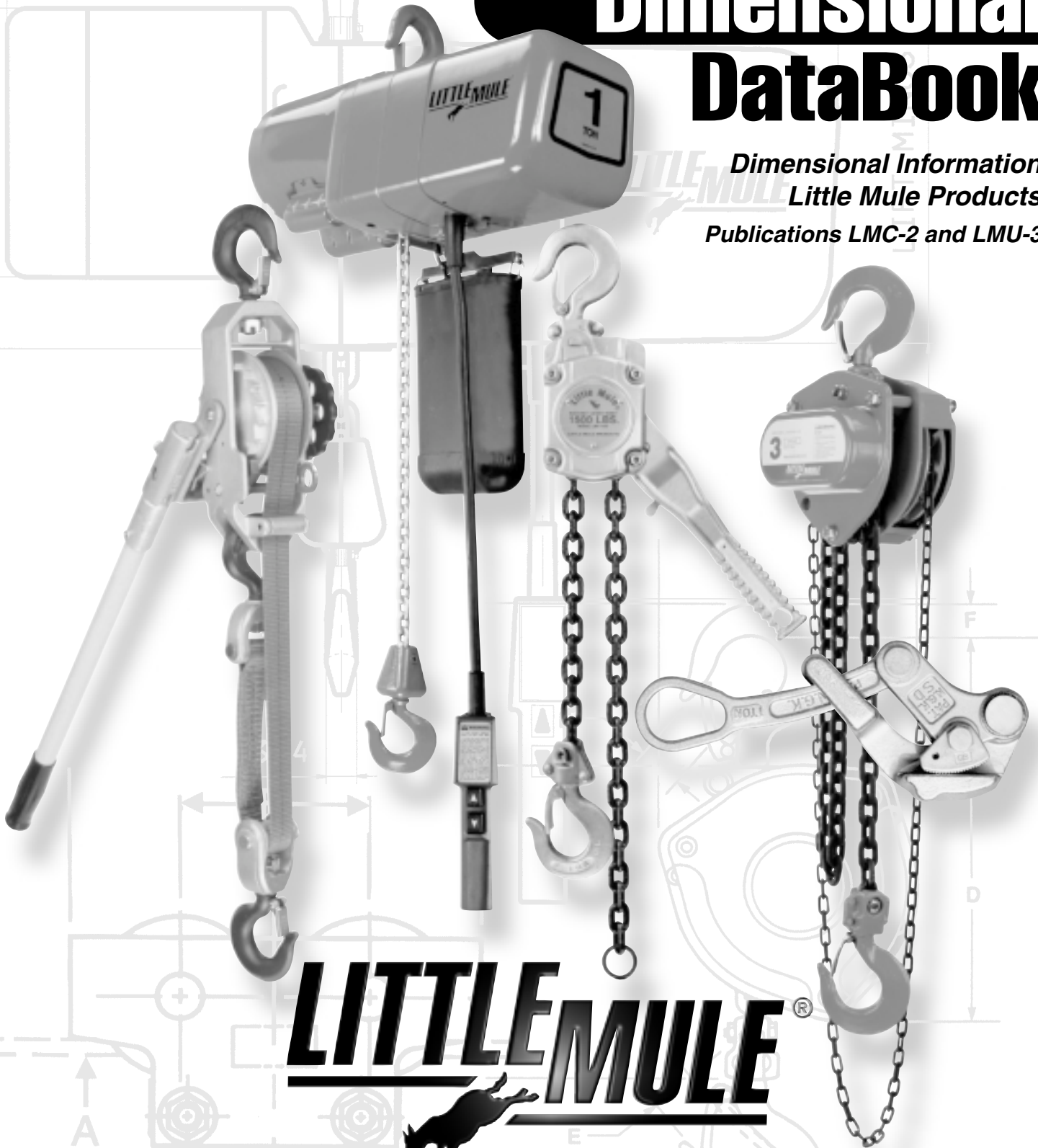

# **LITTLE MULE**®



Cable • Lineman's Strap • Ratchet Lever • Hand Chain • Electric Chain Hoists • Wire Grips • Trolleys • Beam Clamps • Accessories

# ***Products To Pull You Through The Tough Jobs***



***Little Mule® Products  
Make Your Job Easier and  
Keep Your Costs Down***

***LITTLE MULE®***  

***Please Call (800) 477-5003 For More Information***

# TABLE OF CONTENTS



**4, 5** Hoisting Do's & Don'ts

**6** Cable Puller

**7** Lineman's Strap Hoist

**8** LMSB

**9** LMR

**10** LMHA

**11** FEL

**12** SLM

**13** LMES

**14** LMTD

**15** LMTP (G)

**16** Wire Grips

**17** Beam Clamp

**18** RA

**19** G Model

**20** Warranty

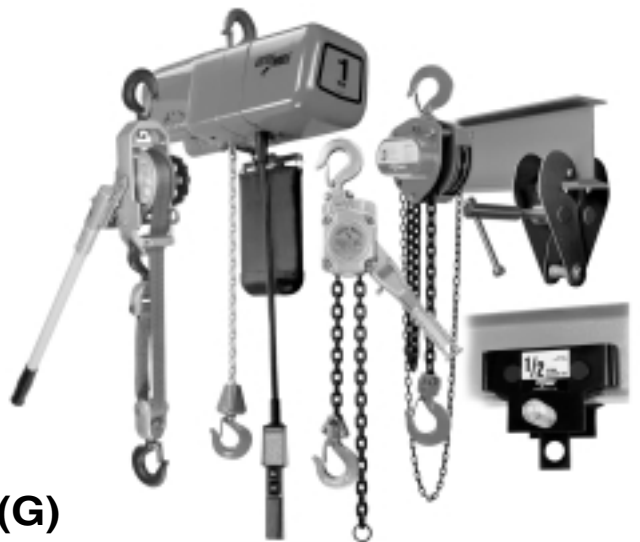
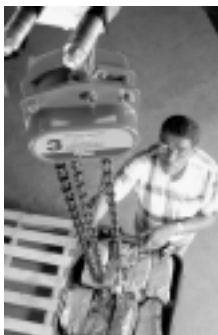

# Safe Hoisting Operations

## Recommendations To Avoid Injury and Property Damage



### Do's

1. **Do** read *ASME/ANSI B30 Series Safety Standard for Manually Operated Hoists* and check with ANSI for any further revisions.
2. **Do** read Hoist Manufacturer's Operating and Maintenance Instructions.
3. **Do** be familiar with operating controls, procedures, and warnings on the unit.
4. **Do** make sure that the unit is securely attached to a suitable support before applying load.
5. **Do** maintain firm footing or be otherwise secured when operating unit.
6. **Do** make sure that load slings or other approved single attachments are properly sized and seated in the hook saddle.
7. **Do** make sure the hook latches, if used, are closed and not supporting any part of the load.
8. **Do** make sure that the load is free to move and will clear all obstructions.
9. **Do** take up slack carefully, check the load balance, move the load a few inches, and check load holding action before continuing.
10. **Do** make sure all persons stay clear of the suspended or supported load.
11. **Do** avoid swinging of load or load hook.
12. **Do** protect load chain from weld spatter or other damaging contaminants.
13. **Do** avoid "fly-back" by keeping a firm grip on the lever (ratchet lever hoist) until operating stroke is completed and the lever is at rest.
14. **Do** promptly report any malfunction, unusual performance, or damage of the unit.
15. **Do** inspect unit regularly, replace damaged or worn parts, and keep appropriate records of maintenance.
16. **Do** use the Hoist Manufacturer's recommended parts when repairing unit.
17. **Do** use hook latches wherever possible.
18. **Do** apply lubricant to load chain as recommended by the Hoist Manufacturer.



### Don'ts

1. **Do Not** lift or pull more than rated load.
2. **Do Not** use hoist load limiting device to measure the load.
3. **Do Not** use damaged hoist or hoist that is not working correctly.
4. **Do Not** use hoist with twisted, kinked, damaged, or worn chain.
5. **Do Not** lift a load unless chain is properly seated in chain wheel(s) or sprocket(s).
6. **Do Not** use load chain as a sling or wrap load chain around the load.
7. **Do Not** lift a load if any binding prevents equal loading on all supporting chains.
8. **Do Not** apply the load to the tip of the hook.
9. **Do Not** operate unless load is centered under hoist.
10. **Do Not** operate the unit when it is restricted from adjusting itself to form a straight line with the direction of loading.
11. **Do Not** operate hoist with other than manual power.
12. **Do Not** permit more than one operator to pull on a single hand chain or lever at one time.
13. **Do Not** operate unit with any lever extension (cheater bar).
14. **Do Not** allow your attention to be diverted from operating the hoist.
15. **Do Not** operate hoist beyond limits of load chain travel.
16. **Do Not** use hoist to lift, support, or transport people.
17. **Do Not** lift loads over people.
18. **Do Not** leave a suspended load unattended unless specific precautions have been taken.
19. **Do Not** attempt to "free chain" unit with any load applied.
20. **Do Not** allow sharp contact between two hoists or between hoist and obstructions.
21. **Do Not** allow the chain or hook to be used as a ground for welding.
22. **Do Not** allow the chain or hook to be touched by a live welding electrode.
23. **Do Not** remove or obstruct the warnings on the hoist.
24. **Do Not** adjust or repair a hoist unless qualified to perform hoist maintenance.
25. **Do Not** attempt to lengthen the load chain or repair damaged load chain.

# Safe Hoisting Operations

## Recommendations To Avoid Injury and Property Damage



### Do's

1. **Do** read *ASME/ANSI B30 Series Safety Standard for Electric and Air Powered Hoists* and check with ANSI for any further revisions.
2. **Do** read Hoist Manufacturer's Operating and Maintenance Instructions.
3. **Do** be familiar with operating controls, procedures, and warnings on the unit.
4. **Do** make sure hook travel is in the same direction as shown on controls.
5. **Do** make sure hoist limit switches function properly.
6. **Do** maintain firm footing when operating hoist.
7. **Do** make sure that load slings or other approved single attachments are properly sized and seated in the hook saddle.
8. **Do** make sure the hook latches, if used, are closed and not supporting any part of the load.
9. **Do** make sure that the load is free to move and will clear all obstructions.
10. **Do** take up slack carefully, check the load balance, move the load a few inches, and check load holding action before continuing.
11. **Do** avoid swinging of load or load hook.
12. **Do** make sure that all persons stay clear of the suspended load.
13. **Do** warn personnel of an approaching load.
14. **Do** protect wire rope and load chain from weld spatter or other damaging contaminants.
15. **Do** promptly report any malfunction, unusual performance, or damage of the unit.
16. **Do** inspect unit regularly, replace damaged or worn parts, and keep appropriate records of maintenance.
17. **Do** use the Hoist Manufacturer's recommended parts when repairing unit.
18. **Do** use hook latches wherever possible.
19. **Do** apply lubricant to the wire rope or load chain as recommended by the Hoist Manufacturer.



### Don'ts

1. **Do Not** lift more than rated load.
2. **Do Not** use hoist load limiting device to measure the load.
3. **Do Not** use damaged hoist or hoist that is not working correctly.
4. **Do Not** use hoist with twisted, kinked, damaged, or worn wire rope or chain.
5. **Do Not** lift a load unless wire rope is properly seated in its groove(s) or unless chain is properly seated in chain wheel(s) or sprocket(s).
6. **Do Not** use load rope or load chain as a sling or wrap load rope or load chain around the load.
7. **Do Not** lift a load if any binding prevents equal loading on all supporting ropes and chains.
8. **Do Not** apply the load to the tip of the hook.
9. **Do Not** operate unless load is centered under hoist.
10. **Do Not** allow your attention to be diverted from operating the hoist.
11. **Do Not** operate hoist beyond limits of load rope or load chain travel.
12. **Do Not** use limit switches as routine operating stops unless recommended. They are emergency devices only.
13. **Do Not** use hoist to lift, support, or transport people.
14. **Do Not** lift loads over people.
15. **Do Not** leave a suspended load unattended unless specific precautions have been taken.
16. **Do Not** allow sharp contact between two hoists or between hoist and obstructions.
17. **Do Not** allow the wire rope, chain, or hook to be used as a ground for welding.
18. **Do Not** allow the wire rope, chain, or hook to be touched by a live welding electrode.
19. **Do Not** remove or obstruct the warnings on the hoist.
20. **Do Not** adjust or repair a hoist unless qualified to perform hoist maintenance.
21. **Do Not** attempt to lengthen the load chain or repair damaged load chain.



## CABLE PULLER HOISTS

Country Club Road  
 P.O. Box 779  
 Wadesboro, NC 28170  
**Phone** (800) 477-5003  
**FAX** (800) 374-6853  
**e-Mail** coffing@cmworks.com

**Cable** 1/2 - 2 Ton

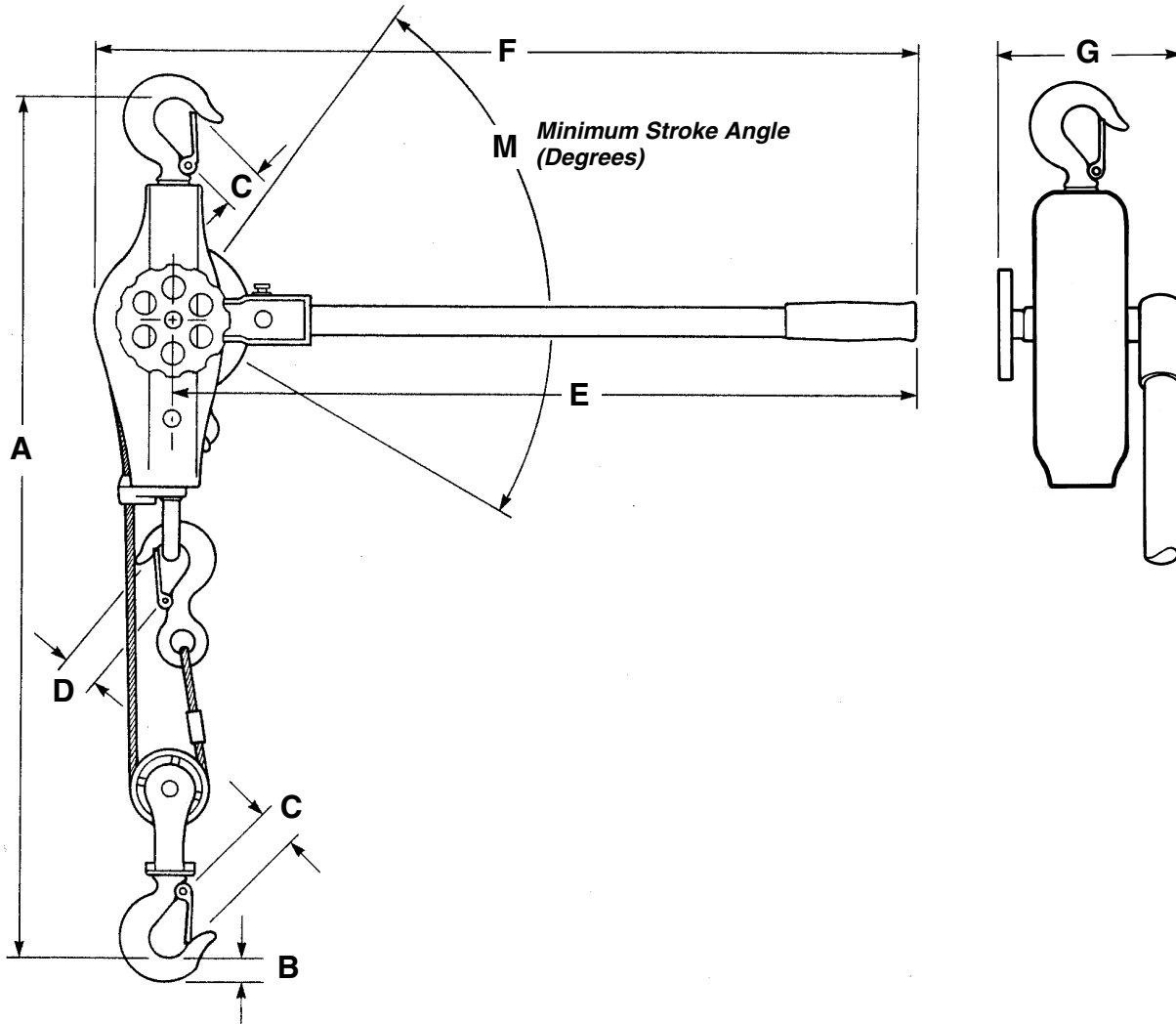

### Dimensions

All Dimensions in Inches Except M

Model Number	Rated Load (Lbs.)		A single	A double	B	C	D	E	F	G	M
	single	double									
115SA	1000	—	19 <sup>1</sup> / <sub>4</sub>	—	1	7/8	1	16 <sup>5</sup> / <sub>8</sub>	18 <sup>3</sup> / <sub>4</sub>	6	21°
115DA	1000	2000	19 <sup>1</sup> / <sub>4</sub>	27 <sup>1</sup> / <sub>2</sub>	1	7/8	1	16 <sup>5</sup> / <sub>8</sub>	18 <sup>3</sup> / <sub>4</sub>	6	21°
505NA	1500	—	19 <sup>3</sup> / <sub>4</sub>	—	1	7/8	1	20 <sup>3</sup> / <sub>4</sub>	23	6	21°
202WNA	1500	3000	19 <sup>3</sup> / <sub>4</sub>	27 <sup>7</sup> / <sub>8</sub>	1	7/8	1	20 <sup>3</sup> / <sub>4</sub>	23	6	21°
434WNA	1500	3000	20 <sup>3</sup> / <sub>4</sub>	29 <sup>1</sup> / <sub>4</sub>	1 <sup>1</sup> / <sub>16</sub>	7/8	1	21 <sup>1</sup> / <sub>4</sub>	23 <sup>3</sup> / <sub>4</sub>	6 <sup>1</sup> / <sub>2</sub>	19°
430CDPA	1500	3000	22 <sup>3</sup> / <sub>4</sub>	33 <sup>3</sup> / <sub>4</sub>	1 <sup>3</sup> / <sub>16</sub>	1 <sup>3</sup> / <sub>16</sub>	1 <sup>1</sup> / <sub>4</sub>	21 <sup>1</sup> / <sub>4</sub>	23 <sup>3</sup> / <sub>4</sub>	6 <sup>1</sup> / <sub>2</sub>	19°
404WNA	2000	4000	21 <sup>1</sup> / <sub>4</sub>	29 <sup>1</sup> / <sub>2</sub>	1 <sup>1</sup> / <sub>16</sub>	7/8	1	25 <sup>1</sup> / <sub>4</sub>	27 <sup>3</sup> / <sub>4</sub>	6 <sup>1</sup> / <sub>2</sub>	19°

**Strap** 3/4 - 2 Ton

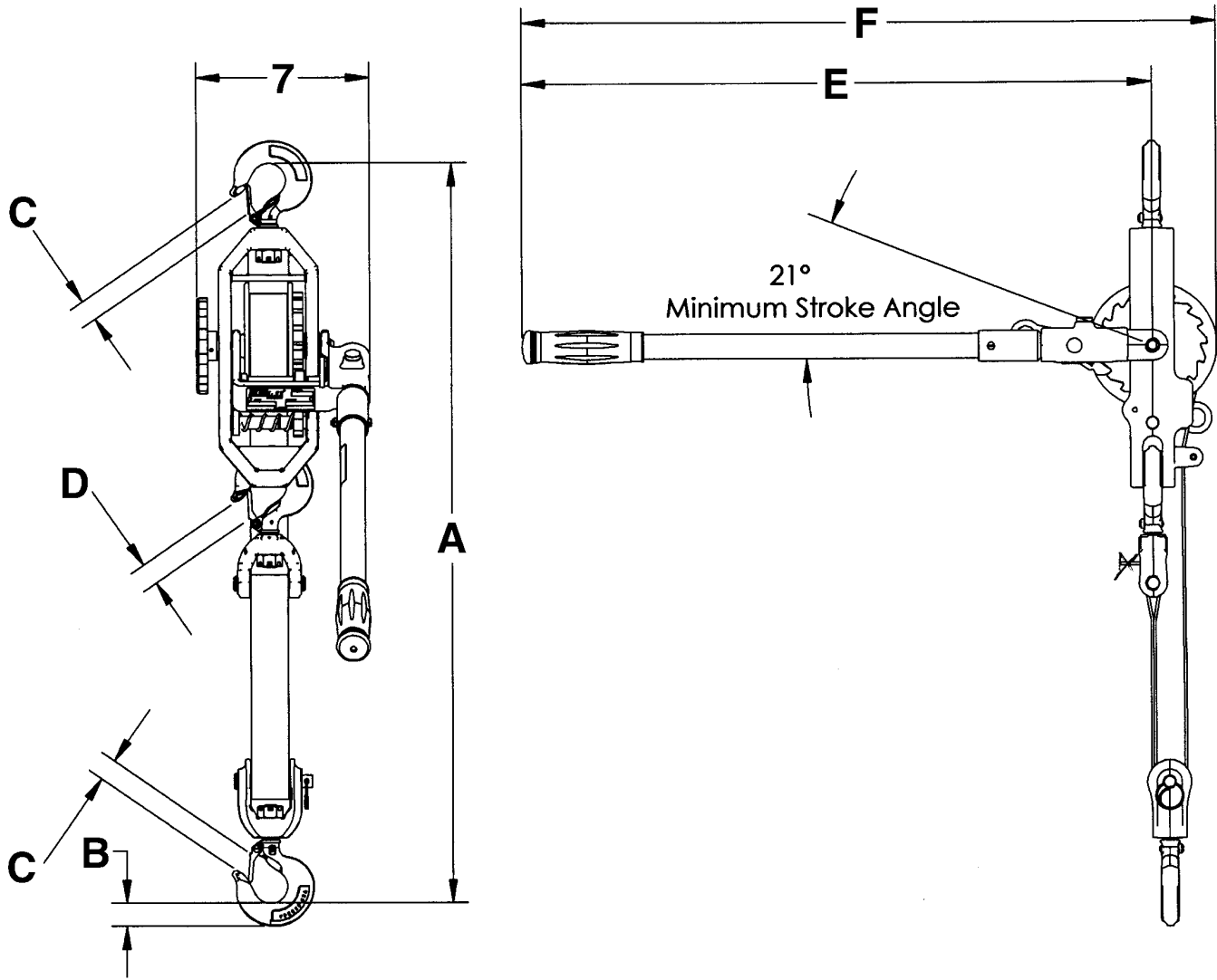

**Dimensions**

Model Number	Rated Load (Lbs.)		A*		B	C	D	E <sup>∞</sup>	F <sup>∞</sup>
	SingleLine	DoubleLine	SingleLine	DoubleLine					
<b>322B</b>	1500	3000	19	23	0.94	0.97	0.97	25.5	27.75
<b>344B</b>	2000	4000	19.32	29.32	1.06	1.06	0.97	31.5	33.75

**Note:** All Dimensions in Inches

- \* With idler removed.
- \*\* Model 322B (stitching is wrapped around idler)  
Model 344B (stitching will NOT wrap around idler)
- ∞ For Hotstick Models add 1.5" to dimension E and F



# RATCHET LEVER HOISTS

Country Club Road  
P.O. Box 779  
Wadesboro, NC 28170  
**Phone** (800) 477-5003  
**FAX** (800) 374-6853  
**e-Mail** [coffing@cmworks.com](mailto:coffing@cmworks.com)

## LMSC 3/4 - 6 Ton

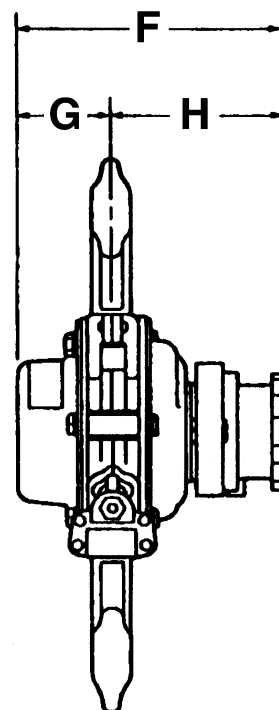
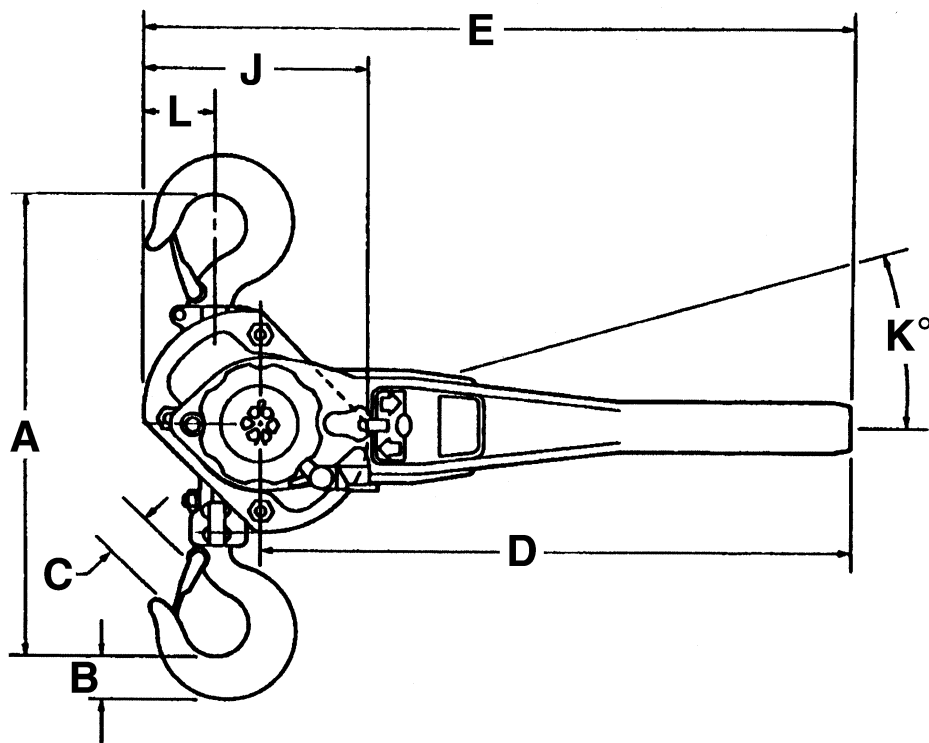

### Dimensions

Model No.	Rated Load (Lbs.)	A	B	C	D	E	F	G	H	J	K	L	No. of Load Chains
LMSC1500	1500	11 <sup>5</sup> / <sub>8</sub>	1 <sup>3</sup> / <sub>16</sub>	1 <sup>5</sup> / <sub>16</sub>	9 <sup>1</sup> / <sub>4</sub>	11 <sup>7</sup> / <sub>16</sub>	5.59	2.06	3.54	4.72	9°	1.50	1
LMSC3000	3000	13	1 <sup>1</sup> / <sub>16</sub>	1 <sup>1</sup> / <sub>4</sub>	14 <sup>9</sup> / <sub>16</sub>	17	6.42	2.54	3.87	5.45	9°	1.62	1
LMSC6000	6000	16 <sup>15</sup> / <sub>16</sub>	1 <sup>3</sup> / <sub>8</sub>	1 <sup>7</sup> / <sub>32</sub>	14 <sup>9</sup> / <sub>16</sub>	18 <sup>3</sup> / <sub>16</sub>	7.28	3.22	4.03	7.00	9°	2.10	1
LMSC12000	12000	22 <sup>3</sup> / <sub>4</sub>	2 <sup>1</sup> / <sub>16</sub>	1 <sup>3</sup> / <sub>4</sub>	14 <sup>9</sup> / <sub>16</sub>	20 <sup>5</sup> / <sub>16</sub>	7.28	3.22	4.03	10.20	9°	3.34	2

All dimensions are in inches unless otherwise indicated.



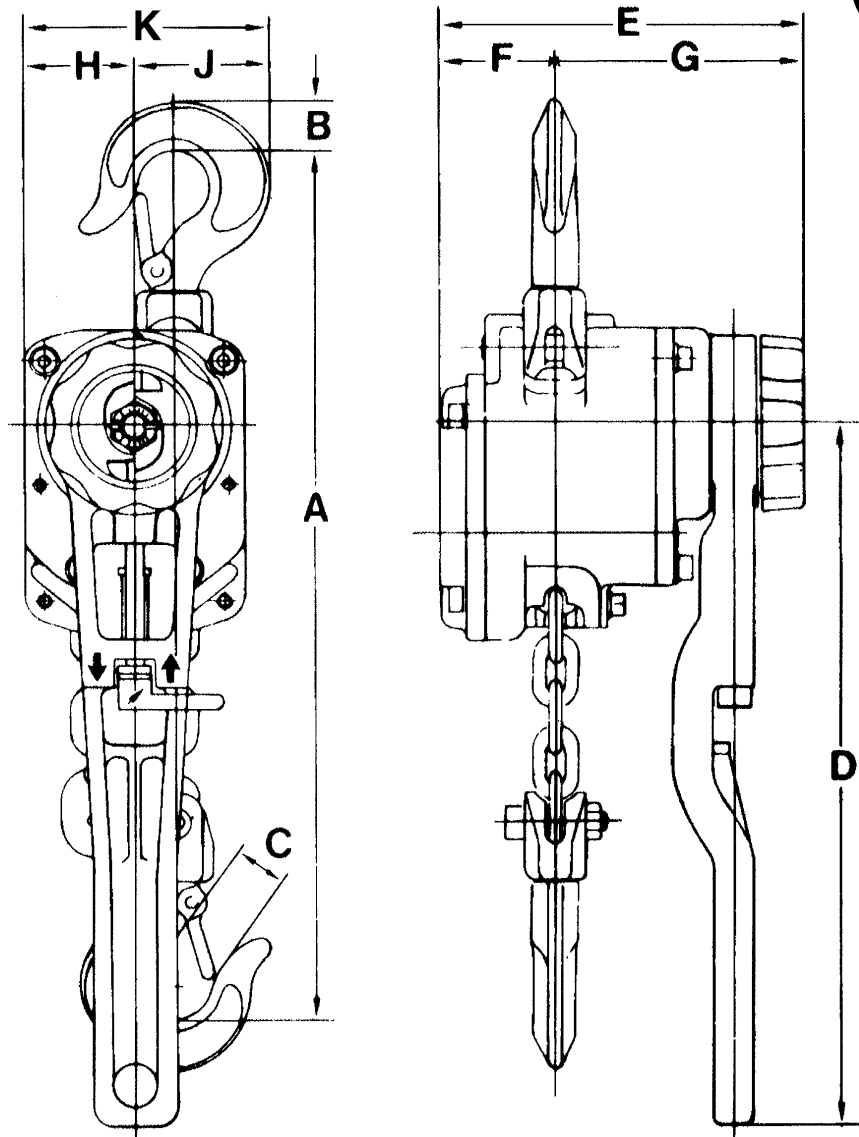

**Dimensions**

Model Number	Rated Load (Ton)	A	B	C	D	E	F	G	H	J	K
LMR-1500	3/4	12	13/16	3/4	12	6 1/4	2	4 1/4	1 7/8	2 1/4	4 1/8
LMR-2000	1	13	1	1	12	6 1/4	2	4 1/4	1 7/8	2 5/8	4 1/2
LMR-3000	1 1/2	14 1/2	1 3/16	1 1/8	12	7	3	4 1/4	2 3/8	3 1/4	5 5/8
LMR-6000	3	17 1/2	1 3/8	1 3/8	16	8 1/2	3 3/4	4 1/4	3	3 3/4	6 3/4

All dimensions are in inches unless otherwise indicated.



# HAND CHAIN HOISTS

Country Club Road  
 P.O. Box 779  
 Wadesboro, NC 28170  
**Phone** (800) 477-5003  
**FAX** (800) 374-6853  
**e-Mail** coffing@cmworks.com

## LMHA 1/2 - 50 Ton

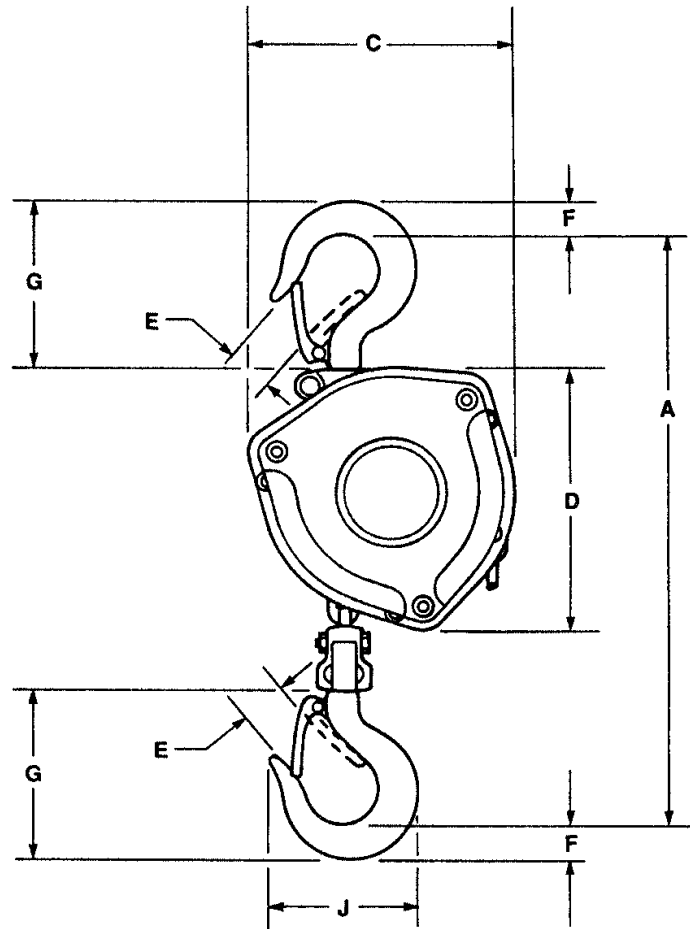
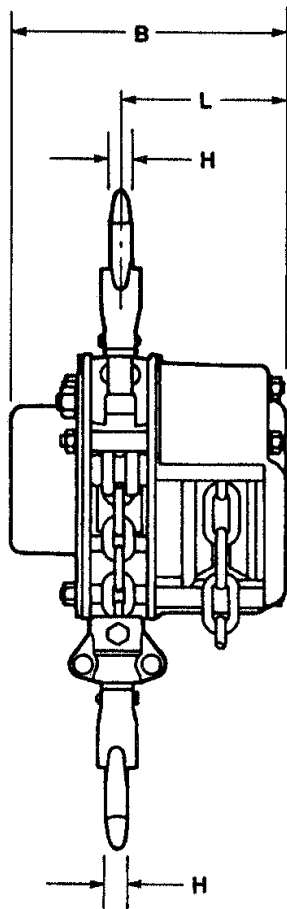

### Dimensions

Model Number	Rated Load (Ton)	A	B	C	D	E	F	G	H	J	K	No. of Load Chains
LMHA-1/2B	1/2	10 <sup>1</sup> / <sub>4</sub>	5 <sup>7</sup> / <sub>16</sub>	5 <sup>7</sup> / <sub>16</sub>	5 <sup>1</sup> / <sub>4</sub>	5 <sup>5</sup> / <sub>16</sub>	5 <sup>5</sup> / <sub>8</sub>	3 <sup>3</sup> / <sub>8</sub>	7 <sup>1</sup> / <sub>16</sub>	2 <sup>15</sup> / <sub>16</sub>	3 <sup>1</sup> / <sub>4</sub>	1
LMHA-1B	1	11 <sup>3</sup> / <sub>16</sub>	5 <sup>15</sup> / <sub>16</sub>	6 <sup>1</sup> / <sub>4</sub>	6	1 <sup>1</sup> / <sub>8</sub>	5 <sup>5</sup> / <sub>16</sub>	4 <sup>1</sup> / <sub>16</sub>	5 <sup>5</sup> / <sub>8</sub>	3 <sup>19</sup> / <sub>32</sub>	3 <sup>7</sup> / <sub>16</sub>	1
LMHA-1 <sup>1</sup> / <sub>2</sub> B	1 <sup>1</sup> / <sub>2</sub>	15 <sup>3</sup> / <sub>4</sub>	6 <sup>1</sup> / <sub>2</sub>	7 <sup>1</sup> / <sub>4</sub>	6 <sup>1</sup> / <sub>8</sub>	1 <sup>5</sup> / <sub>16</sub>	1 <sup>1</sup> / <sub>8</sub>	3 <sup>9</sup> / <sub>16</sub>	1 <sup>3</sup> / <sub>16</sub>	4	3 <sup>5</sup> / <sub>8</sub>	1
LMHA-2B	2	15	7 <sup>1</sup> / <sub>4</sub>	8 <sup>7</sup> / <sub>16</sub>	8 <sup>1</sup> / <sub>2</sub>	1 <sup>3</sup> / <sub>8</sub>	1 <sup>1</sup> / <sub>4</sub>	4 <sup>15</sup> / <sub>16</sub>	7 <sup>7</sup> / <sub>8</sub>	4 <sup>9</sup> / <sub>16</sub>	3 <sup>7</sup> / <sub>8</sub>	1
LMHA-3B	3	17 <sup>1</sup> / <sub>8</sub>	7 <sup>13</sup> / <sub>16</sub>	10	10	1 <sup>9</sup> / <sub>16</sub>	1 <sup>1</sup> / <sub>2</sub>	5 <sup>3</sup> / <sub>4</sub>	1 <sup>1</sup> / <sub>8</sub>	5 <sup>7</sup> / <sub>16</sub>	4 <sup>3</sup> / <sub>8</sub>	1
LMHA-5B	5	22 <sup>5</sup> / <sub>8</sub>	6 <sup>1</sup> / <sub>2</sub>	11 <sup>1</sup> / <sub>8</sub>	7 <sup>5</sup> / <sub>16</sub>	1 <sup>7</sup> / <sub>8</sub>	1 <sup>13</sup> / <sub>16</sub>	6 <sup>13</sup> / <sub>16</sub>	1 <sup>3</sup> / <sub>8</sub>	6 <sup>1</sup> / <sub>2</sub>	3 <sup>5</sup> / <sub>8</sub>	3
LMHA-8B	8	32 <sup>1</sup> / <sub>2</sub>	7 <sup>13</sup> / <sub>16</sub>	15 <sup>1</sup> / <sub>16</sub>	—	2 <sup>3</sup> / <sub>4</sub>	2 <sup>1</sup> / <sub>2</sub>	9 <sup>17</sup> / <sub>32</sub>	1 <sup>13</sup> / <sub>16</sub>	8 <sup>3</sup> / <sub>4</sub>	4 <sup>3</sup> / <sub>16</sub>	3
LMHA-10B	10	32 <sup>1</sup> / <sub>2</sub>	7 <sup>13</sup> / <sub>16</sub>	15 <sup>1</sup> / <sub>16</sub>	—	2 <sup>3</sup> / <sub>4</sub>	2 <sup>1</sup> / <sub>2</sub>	9 <sup>17</sup> / <sub>32</sub>	1 <sup>13</sup> / <sub>16</sub>	8 <sup>3</sup> / <sub>4</sub>	4 <sup>3</sup> / <sub>16</sub>	3
LMHA-12B	12	50 <sup>5</sup> / <sub>8</sub>	7 <sup>13</sup> / <sub>16</sub>	20 <sup>5</sup> / <sub>16</sub>	—	2 <sup>15</sup> / <sub>16</sub>	2 <sup>27</sup> / <sub>32</sub>	11 <sup>3</sup> / <sub>16</sub>	2 <sup>7</sup> / <sub>16</sub>	10 <sup>11</sup> / <sub>16</sub>	4 <sup>3</sup> / <sub>16</sub>	5
LMHA-15B	15	50 <sup>5</sup> / <sub>8</sub>	7 <sup>13</sup> / <sub>16</sub>	20 <sup>5</sup> / <sub>16</sub>	—	2 <sup>15</sup> / <sub>16</sub>	2 <sup>27</sup> / <sub>32</sub>	11 <sup>3</sup> / <sub>16</sub>	2 <sup>7</sup> / <sub>16</sub>	10 <sup>11</sup> / <sub>16</sub>	4 <sup>3</sup> / <sub>16</sub>	5
LMHA-20B	20	52 <sup>3</sup> / <sub>8</sub>	12 <sup>1</sup> / <sub>8</sub>	28 <sup>7</sup> / <sub>8</sub>	—	3 <sup>1</sup> / <sub>8</sub>	3 <sup>9</sup> / <sub>16</sub>	12 <sup>9</sup> / <sub>16</sub>	3 <sup>9</sup> / <sub>16</sub>	12 <sup>1</sup> / <sub>2</sub>	6 <sup>1</sup> / <sub>16</sub>	6
LMHA-25B	25	52 <sup>7</sup> / <sub>8</sub>	14 <sup>1</sup> / <sub>2</sub>	28 <sup>7</sup> / <sub>8</sub>	—	3 <sup>1</sup> / <sub>8</sub>	3 <sup>1</sup> / <sub>2</sub>	12 <sup>9</sup> / <sub>16</sub>	3 <sup>9</sup> / <sub>16</sub>	12 <sup>1</sup> / <sub>2</sub>	7 <sup>1</sup> / <sub>4</sub>	8
LMHA-30B	30	65	16 <sup>7</sup> / <sub>8</sub>	29 <sup>5</sup> / <sub>8</sub>	—	4 <sup>3</sup> / <sub>16</sub>	4 <sup>31</sup> / <sub>32</sub>	18 <sup>3</sup> / <sub>16</sub>	4 <sup>7</sup> / <sub>16</sub>	15 <sup>3</sup> / <sub>16</sub>	8 <sup>7</sup> / <sub>16</sub>	10
LMHA-40B	40	73 <sup>5</sup> / <sub>16</sub>	20 <sup>1</sup> / <sub>8</sub>	29 <sup>5</sup> / <sub>8</sub>	—	4 <sup>1</sup> / <sub>16</sub>	6 <sup>3</sup> / <sub>16</sub>	22 <sup>1</sup> / <sub>4</sub>	5 <sup>1</sup> / <sub>4</sub>	17 <sup>5</sup> / <sub>8</sub>	10 <sup>1</sup> / <sub>16</sub>	14
LMHA-50B	50	77 <sup>5</sup> / <sub>8</sub>	25 <sup>7</sup> / <sub>8</sub>	29 <sup>5</sup> / <sub>8</sub>	—	4 <sup>3</sup> / <sub>4</sub>	6 <sup>3</sup> / <sub>4</sub>	23 <sup>3</sup> / <sub>4</sub>	6 <sup>7</sup> / <sub>8</sub>	20 <sup>1</sup> / <sub>4</sub>	12 <sup>15</sup> / <sub>16</sub>	20

Dimensions are in inches unless otherwise indicated.

**FEL** 1/4 - 2 Ton

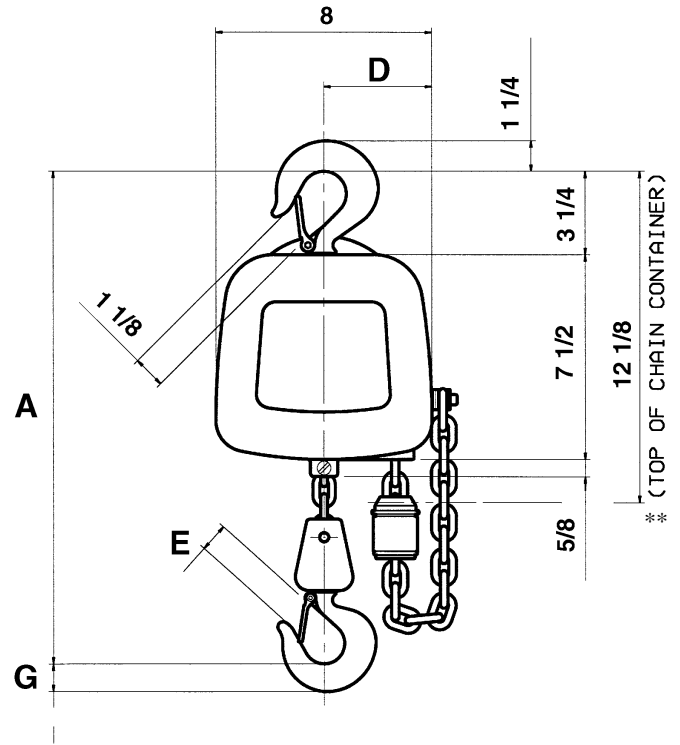
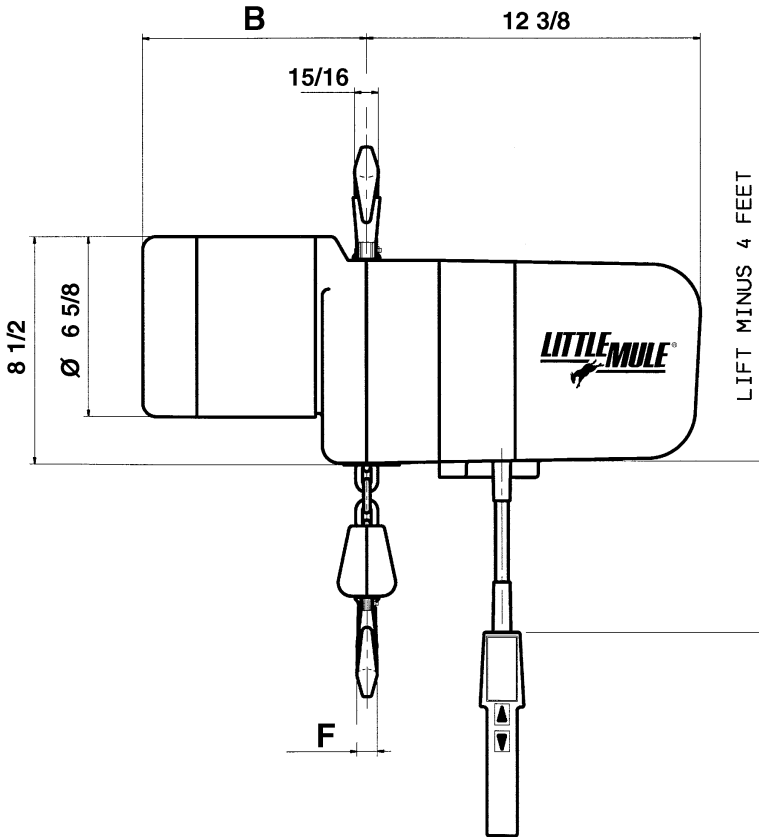

**Hoist Dimensions**

Model Number	Rated Load (Lbs.)	B	
		1-PH	3-PH
FEL-0232	250	9 1/8"	8 1/8"
FEL-0516	500	9 1/8"	8 1/8"
FEL-0532	500	9 1/8"	8 1/8"
FEL-1016	1000	9 1/8"	8 1/8"
FEL-1032	1000	10 1/8"	8 5/8"
FEL-2016	2000	10 1/8"	8 5/8"
FEL-4008	4000	10 1/8"	8 5/8"

**Hoist Dimensions**

Number Of Chains	A*	D	E	F	G
	SINGLE	18"	4"	1"	7/8"
DOUBLE	22"	4 7/8"	1 1/8"	15/16"	1 1/4"

**NOTE:** All units single chain except 2 ton.  
\* "A" Dimension allows 2" clearance between load block and underside of hoist on single chain models and 1" on double chain models.

**CHAIN CONTAINER**

Part Number	C	Capacity (Hoist Lift In Feet)	
		FEL 1 Ton & Under (Single Chain)	FEL 2 Ton (Double Chain)
JL927-1	11 1/2"	20'	10'
JL927-3	18 1/2"	35'	17'
JL927-4	27"	50'	25'

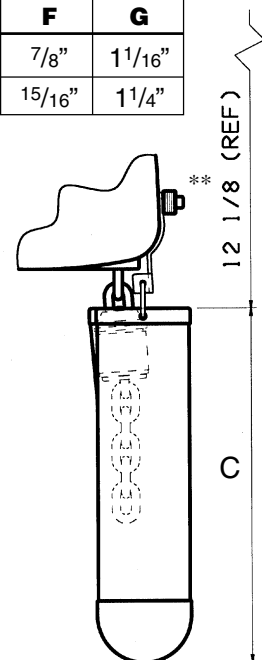

**Chain Container Option**



ELECTRIC CHAIN HOISTS

Country Club Road  
 P.O. Box 779  
 Wadesboro, NC 28170  
**Phone** (800) 477-5003  
**FAX** (800) 374-6853  
**e-Mail** coffing@cmworks.com

**SLC** 1/8 - 1/2 Ton

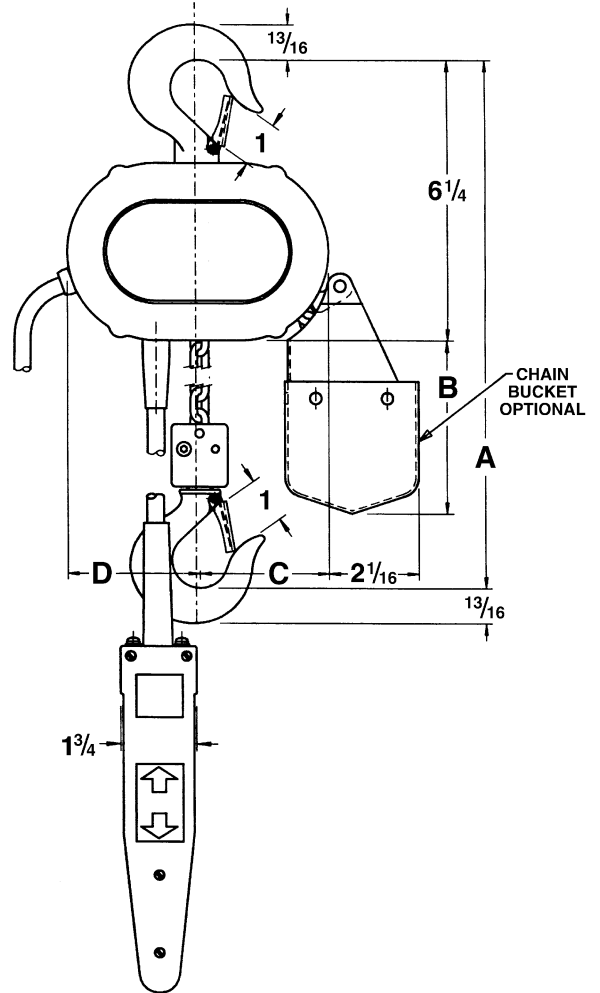
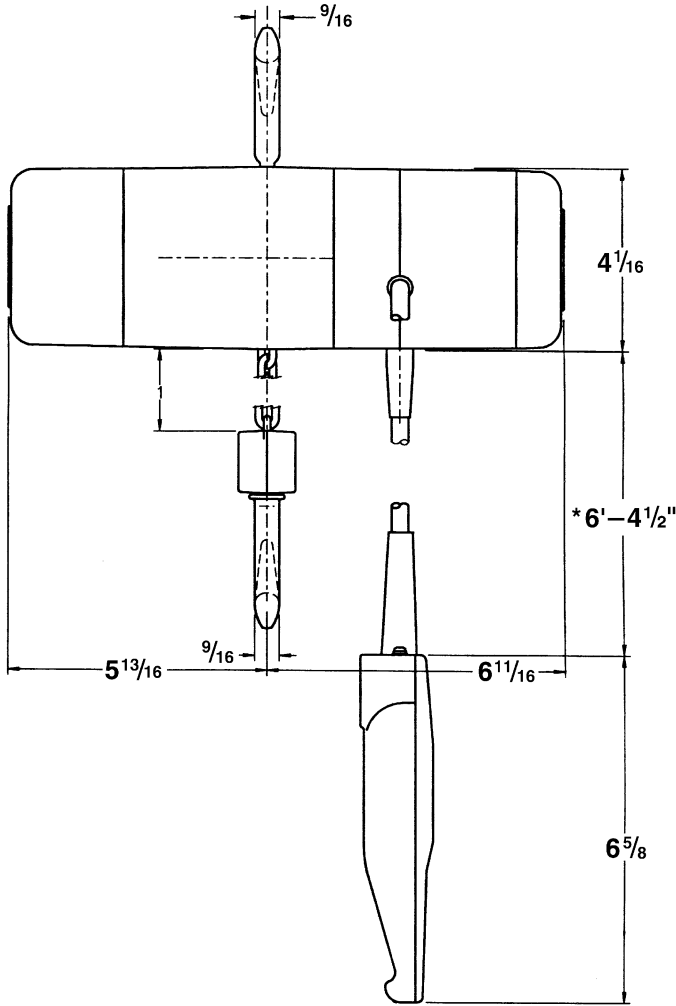

Reeving	A	B	C	D
single	11 <sup>1</sup> / <sub>16</sub>	3 <sup>7</sup> / <sub>8</sub>	2 <sup>15</sup> / <sub>16</sub>	3
double	12 <sup>1</sup> / <sub>8</sub>	5 <sup>3</sup> / <sub>4</sub>	2 <sup>3</sup> / <sub>8</sub>	3 <sup>9</sup> / <sub>16</sub>

All dimensions in inches

\* Dimension based on 10 ft. lift—  
 will vary depending on actual lift

**LMES** 1/4 - 1/2 Ton

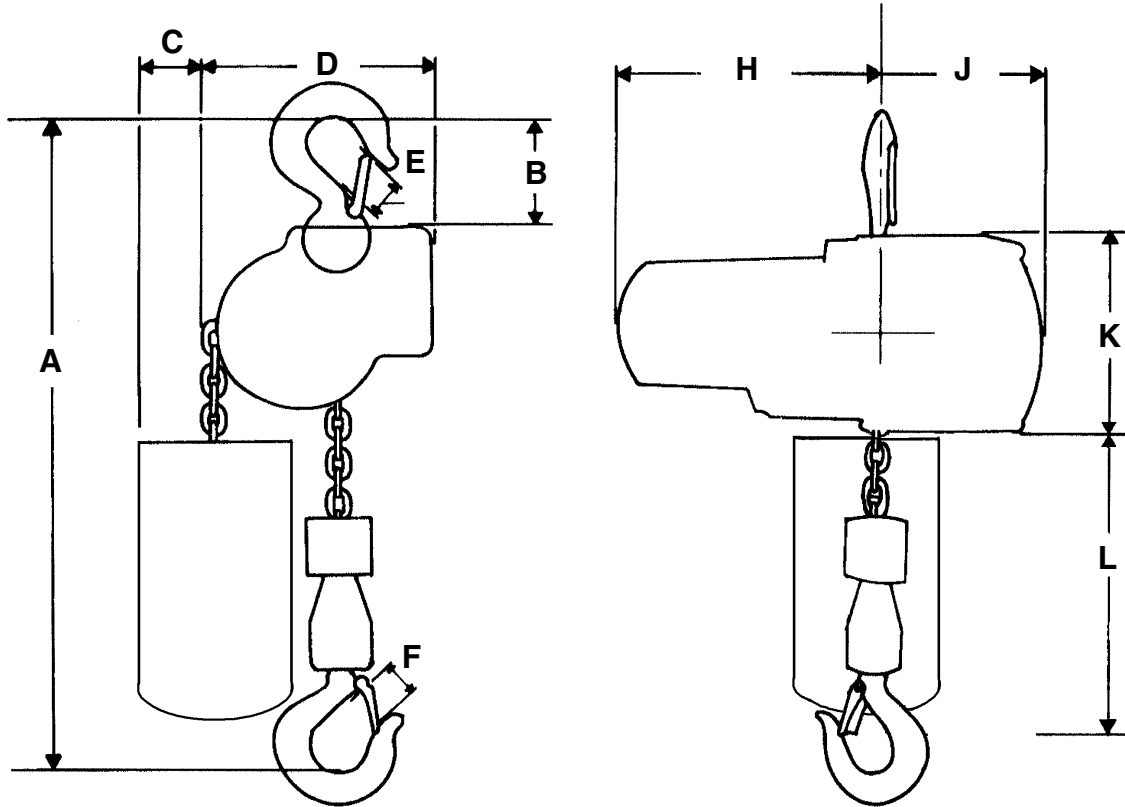

**Dimensions**

Model Number	Rated Load (Ton)	A	B	C	D	E	F	H	J	K	L
LMES-0512-10	1/4	15	3	2	5 1/4	3/4	3/4	6	3 3/4	4 1/4	8 1/2
LMES-0512-20	1/4	15	3	2	5 1/4	3/4	3/4	6	3 3/4	4 1/4	8 1/2
LMES-0512-10	1/2	15	3	2	5 1/4	3/4	3/4	6	3 3/4	4 1/4	8 1/2

Dimensions are in inches unless otherwise indicated.



PLAIN TROLLEYS

Country Club Road  
P.O. Box 779  
Wadesboro, NC 28170  
**Phone** (800) 477-5003  
**FAX** (800) 374-6853  
**e-Mail** [coffing@cmworks.com](mailto:coffing@cmworks.com)

**LMTD** 1/4 - 5 Ton

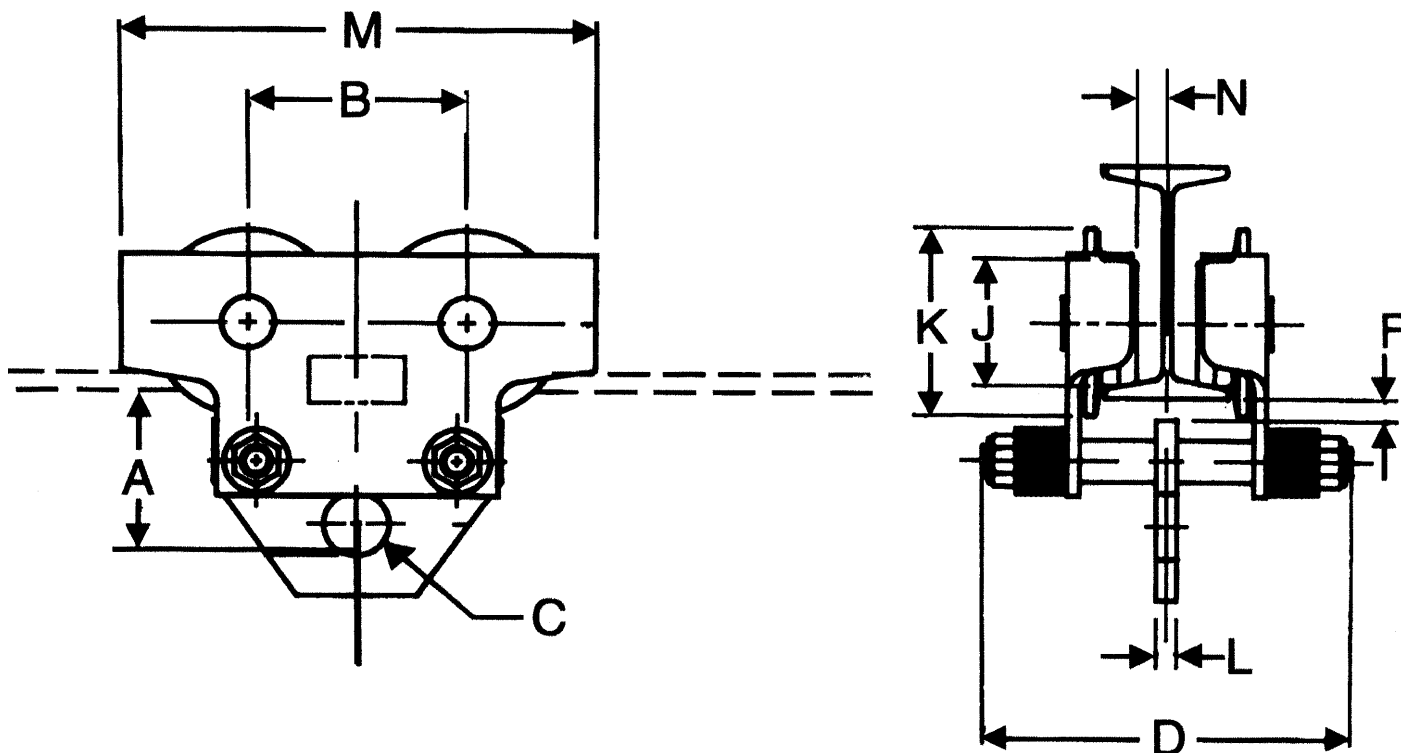

**Dimensions**

Model Number	Rated Load (Ton)	A	B	C	D	F	J	K	L	M	N	Flange Width	Radius
LMTD-500	1/4	37/8	4 1/8	1 17/64	11 3/4	9/16	2 1/4	37/16	3/8	89/16	7/8	2.66 - 8.05	36
LMTD-1000	1/2	37/8	4 1/8	1 17/64	11 3/4	9/16	2 1/4	37/16	3/8	89/16	7/8	2.66 - 8.05	36
LMTD-2000	1	37/8	49/16	2 1/4	12	1/2	2 3/4	4 1/16	1/2	97/8	7/8	3.00 - 8.05	48
LMTD-3000	1 1/2	47/8	6 1/4	2 1/4	12 5/8	5/8	4 1/4	5 3/4	1/2	13 1/2	1 1/4	3.33 - 8.05	60
LMTD-4000	2	47/8	6 1/4	2 1/4	12 5/8	5/8	4 1/4	5 3/4	1/2	13 1/2	1 1/4	3.33 - 8.05	60
LMTD-6000	3	4 5/8	6 3/8	2 1/4	13 3/8	23/32	4 1/4	5 3/4	1/2	14 1/8	1 1/4	4.00 - 8.05	60
LMTD-10000	5	5 3/8	6 3/4	2 1/2	14 3/4	15/16	4 3/8	6 3/16	5/8	15 7/16	1 5/8	4.60 - 8.05	60

**NOTE:** All dimensions in inches unless otherwise indicated.

**LMTP(G) 8 - 16 Ton**

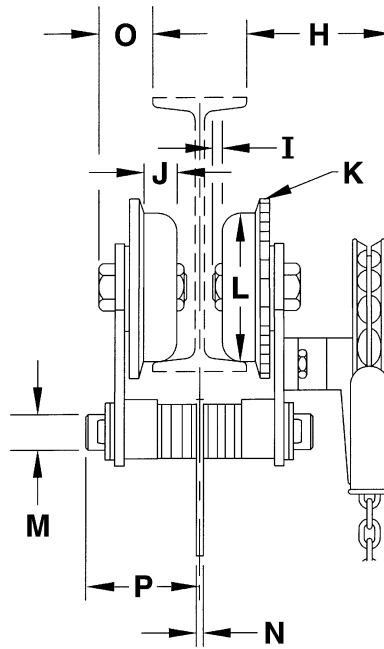
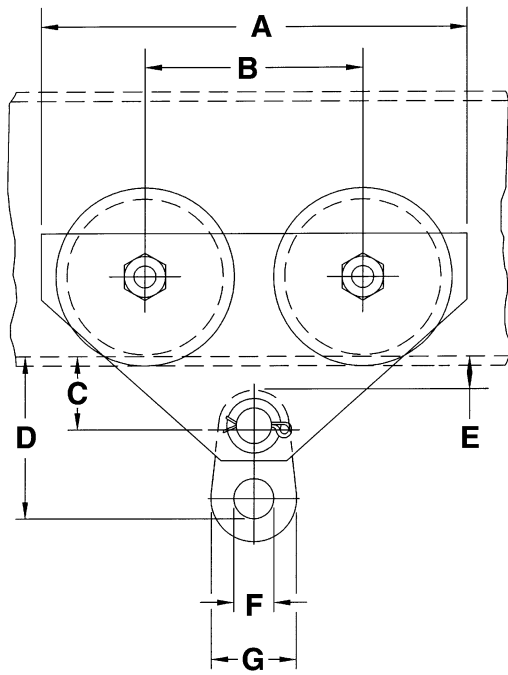

GEARED

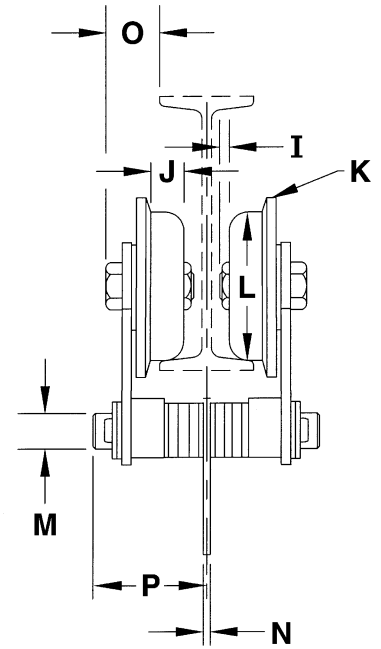

PLAIN

Model Number	Rated Load (Tons)	A	B	C	D	E	F	G	H	I	J	K	L	M	N	O	P
LMTP(G)-16000	8	23 <sup>5</sup> / <sub>8</sub>	10 <sup>5</sup> / <sub>8</sub>	3 <sup>7</sup> / <sub>8</sub>	10 <sup>5</sup> / <sub>8</sub>	1 <sup>3</sup> / <sub>8</sub>	3 <sup>1</sup> / <sub>2</sub>	6 <sup>1</sup> / <sub>2</sub>	9	1 <sup>1</sup> / <sub>8</sub>	11 <sup>11</sup> / <sub>16</sub>	10	8 <sup>1</sup> / <sub>4</sub>	2 <sup>1</sup> / <sub>2</sub>	3 <sup>3</sup> / <sub>4</sub>	3 <sup>1</sup> / <sub>4</sub>	6 <sup>7</sup> / <sub>8</sub>
LMTP(G)-20000	10	23 <sup>5</sup> / <sub>8</sub>	10 <sup>5</sup> / <sub>8</sub>	3 <sup>7</sup> / <sub>8</sub>	11 <sup>1</sup> / <sub>8</sub>	1 <sup>3</sup> / <sub>8</sub>	4 <sup>1</sup> / <sub>2</sub>	8	9	1 <sup>1</sup> / <sub>8</sub>	11 <sup>11</sup> / <sub>16</sub>	10	8 <sup>1</sup> / <sub>4</sub>	2 <sup>1</sup> / <sub>2</sub>	1	3 <sup>1</sup> / <sub>4</sub>	6 <sup>7</sup> / <sub>8</sub>
LMTP(G)-24000	12	23 <sup>5</sup> / <sub>8</sub>	10 <sup>5</sup> / <sub>8</sub>	3 <sup>7</sup> / <sub>8</sub>	11 <sup>1</sup> / <sub>8</sub>	1 <sup>3</sup> / <sub>8</sub>	4 <sup>1</sup> / <sub>2</sub>	8	9	1 <sup>1</sup> / <sub>8</sub>	11 <sup>11</sup> / <sub>16</sub>	10	8 <sup>1</sup> / <sub>4</sub>	2 <sup>1</sup> / <sub>2</sub>	1	3 <sup>1</sup> / <sub>4</sub>	6 <sup>7</sup> / <sub>8</sub>
LMTP(G)-32000	16	28 <sup>1</sup> / <sub>4</sub>	14	5 <sup>7</sup> / <sub>8</sub>	15 <sup>1</sup> / <sub>4</sub>	2 <sup>1</sup> / <sub>2</sub>	4	9	14 <sup>1</sup> / <sub>2</sub>	5 <sup>5</sup> / <sub>16</sub>	2	13 <sup>1</sup> / <sub>2</sub>	11 <sup>3</sup> / <sub>4</sub>	3 <sup>1</sup> / <sub>4</sub>	1 <sup>1</sup> / <sub>2</sub>	7	8

**Notes:** All dimensions are in inches.  
Wheels with convex treads are standard on all capacities.  
20, 25, 30 and 40 ton trolleys can be furnished in tandem construction - 30 and 40 ton dimensions furnished upon application.

\* Dimensions shown are for minimum beam size and will vary proportionately for larger beams.

Model Number	Radius	Beam Size
LMTP(G)16000	72	10 - 24
LMTP(G)20000	72	10 - 24
LMTP(G)24000	72	10 - 24
LMTP(G)32000	96	18 - 24

**WG** 1/2 - 10 Ton

**SPECIFICATIONS**

**Standard and Hot Line Models 1,000 - 20,000 Lbs.**

Model Number	Type	Capacity (Lbs.)	Net Weight (Lbs.)	Wire Size				Handle Eye Opening (In.)
				Minimum		Maximum		
				Size (In.)	Gauge	Size (In.)	Gauge	
LMG1000	Standard Grip Spring Loaded	1000	1/2	.04	18AWG	.394	1/0AWG	.625 dia.
LMG2000		2000	1	.109	8AWG	.594	4/0AWG	1 x 1 1/2
LMG4500		5000	3 1/4	.18	6AWG	.60	4/0AWG	1 1/4 x 1 3/4
LMG4600		10000	4 1/2	.30	1AWG	.80	450MCM	1 1/4 x 1 3/4
LMG4800		12000	8	.70	397MCM	1.25	1130MCM	1 1/4 x 1 3/4
LMG4700		20000	21	.70	397MCM	1.25	1130MCM	2 1/2 x 3 1/2
LMG4501	Hot Line Grip Spring Loaded Notched Handle	5000	3 1/4	.18	6AWG	.60	4/0AWG	1 1/4 x 1 3/4
LMG4601		10000	4 1/2	.30	1AWG	.80	450MCM	1 1/4 x 1 3/4
LMG4801		12000	8	.70	397MCM	1.25	1130MCM	1 1/4 x 1 3/4
LMG4701		20000	21	.70	397MCM	1.25	1130MCM	2 1/2 x 3 1/2
LMG4502	Hot Line Grip No Spring No Notch	5000	3 1/4	.18	6AWG	.60	4/0AWG	1 1/4 x 1 3/4
LMG4602		10000	4 1/2	.30	1AWG	.80	450MCM	1 1/4 x 1 3/4
LMG4802		12000	8	.70	397MCM	1.25	1130MCM	1 1/4 x 1 3/4
LMG4702		20000	21	.70	397MCM	1.25	1130MCM	2 1/2 x 3 1/2

*Note: 1000 and 2000 lb. models have Bulldog-type jaw with aggressive teeth. All other models have parallel jaw. All dimensions in inches.*

**DIMENSIONAL DRAWING - Wire Grips**

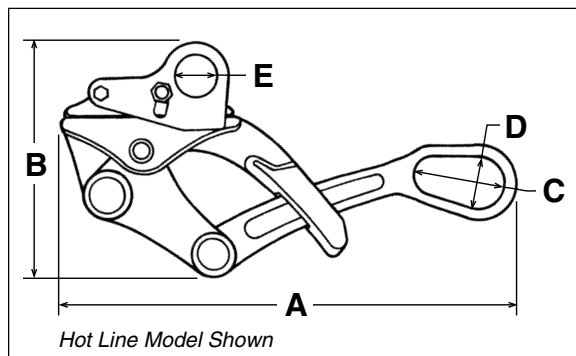

Model	A	B	C	D	E
LMG1000	5 5/16	2 7/16	5/8	5/8	—
LMG2000	7 3/4	3 1/8	1 1/2	1	—
LMG4500	11	4 1/4	2	1 1/4	—
LMG4600	11 3/4	5 1/4	2 1/4	1 3/8	—
LMG4800	13 3/4	5 1/4	2 1/4	1 3/8	—
LMG4700	19 5/8	7 1/4	3 5/8	2 9/16	—
LMG4501	11	5	2	2 1/4	1
LMG4601	12 3/4	5 7/8	2 1/4	1 3/8	1 3/16
LMG4801	13 3/4	6 1/2	2 1/4	1 3/8	1 3/16
LMG4701	19 5/8	8 1/4	3 5/8	2 9/16	1
LMG4502	11	5	2	1 1/4	1
LMG4602	12 3/4	5 7/8	2 1/4	1 3/8	1 3/16
LMG4802	13 3/4	6 1/2	2 1/4	1 3/8	1 3/16
LMG4702	19 5/8	8 1/4	3 5/8	2 9/16	1



**BC** 1 - 10 Ton

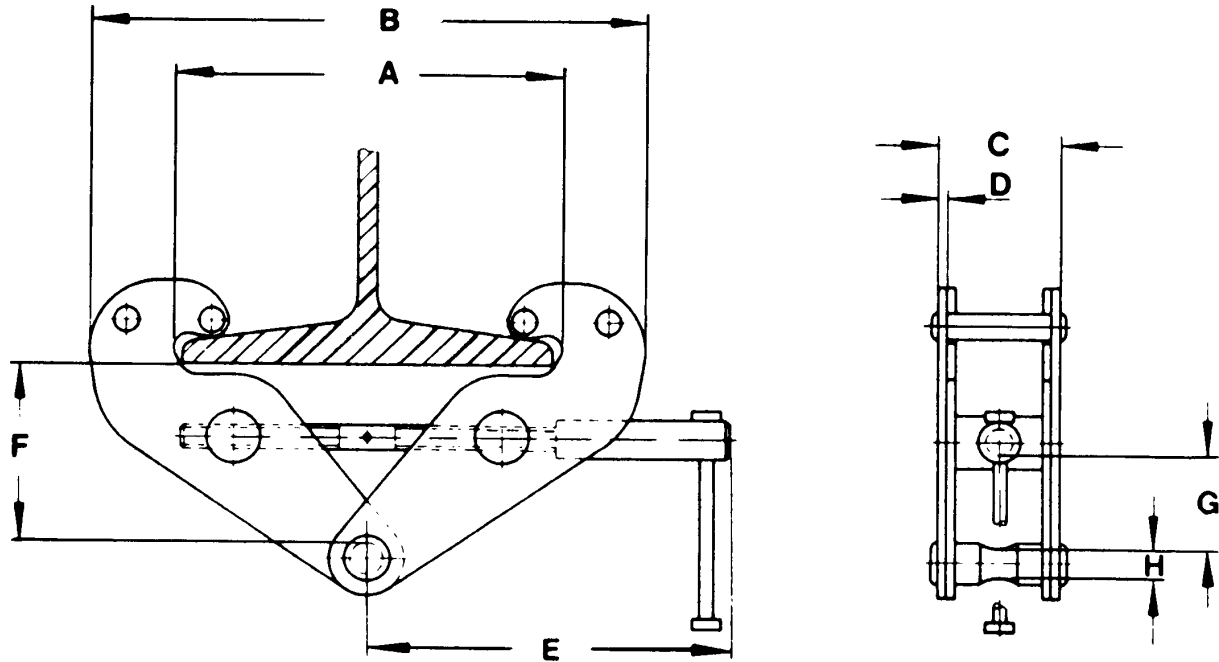

**Specifications**

Model Number	Rated Load (Lbs.)	Flange Width (Ins.)	Net Weight (Lbs.)
BC-1	2000	3-9	8.8
BC-2	4000	3-9	13.2
BC-3	6000	3.2 - 12.6	17.6
BC-5	10000	3.6 - 12.2	22.0
BC-10	20000	3.6 - 12.6	32.0

**Dimensions**

Model Number	A Max.	B		C (In.)	D (In.)	E (In.)	F		G Min.	H
		Min.	Max.				Max.	Min.		
BC-1	10.6	6.9	14.4	2.9	0.2	8.4	5.4	2.9	1.2	.80
BC-2	10.6	7.3	15.0	2.9	0.2	8.4	5.4	2.9	1.2	.80
BC-3	11.6	8.7	16.7	4.0	0.3	10.0	6.3	4.1	2.4	.87
BC-5	12.6	9.8	18.7	4.0	0.3	10.0	6.3	3.5	1.8	1.10
BC-10	12.6	10.5	18.9	4.6	0.47	10.8	7.2	5.2	2.6	1.50

All dimensions are in inches unless otherwise indicated.

**RA** 3/4 - 6 Ton

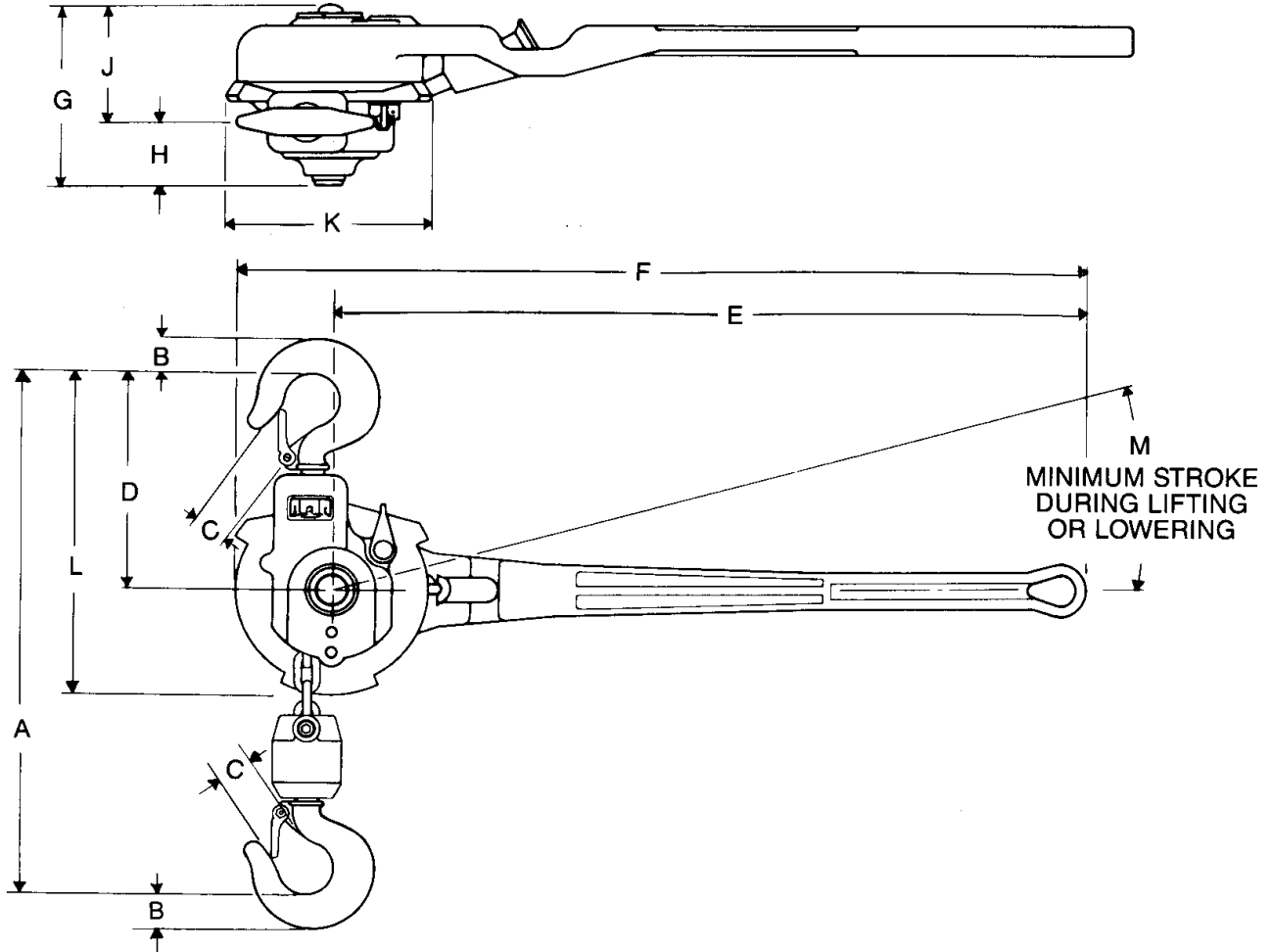

**Dimensions**

Model Number	Rated Load		A	B	C*	D	E	F	G	H	J	K	L	M
	(Lbs.)	(Ton)												
RA-15	1500	3/4	12 <sup>7</sup> / <sub>16</sub>	1	1	6	20 <sup>1</sup> / <sub>2</sub>	23	4 <sup>5</sup> / <sub>8</sub>	1 <sup>5</sup> / <sub>8</sub>	3	5 <sup>1</sup> / <sub>4</sub>	9	36°
RA-20	2000	3/4	12 <sup>7</sup> / <sub>16</sub>	1	1	6	20 <sup>1</sup> / <sub>2</sub>	23	4 <sup>5</sup> / <sub>8</sub>	1 <sup>5</sup> / <sub>8</sub>	3	5 <sup>1</sup> / <sub>4</sub>	9	36°
RA-15-2	3000	1 <sup>1</sup> / <sub>2</sub>	17 <sup>1</sup> / <sub>4</sub>	1 <sup>5</sup> / <sub>16</sub>	1	7 <sup>1</sup> / <sub>8</sub>	20 <sup>1</sup> / <sub>2</sub>	23 <sup>3</sup> / <sub>4</sub>	4 <sup>5</sup> / <sub>8</sub>	1 <sup>5</sup> / <sub>8</sub>	3	5 <sup>5</sup> / <sub>8</sub>	10 <sup>1</sup> / <sub>8</sub>	36°
RA-30	3000	1 <sup>1</sup> / <sub>2</sub>	13 <sup>3</sup> / <sub>4</sub>	1 <sup>1</sup> / <sub>8</sub>	1 <sup>1</sup> / <sub>8</sub>	7 <sup>1</sup> / <sub>4</sub>	20 <sup>1</sup> / <sub>2</sub>	24 <sup>3</sup> / <sub>4</sub>	7	2 <sup>7</sup> / <sub>8</sub>	4 <sup>1</sup> / <sub>8</sub>	6 <sup>7</sup> / <sub>8</sub>	10 <sup>1</sup> / <sub>4</sub>	36°
RA-40	4000	1 <sup>1</sup> / <sub>2</sub>	13 <sup>3</sup> / <sub>4</sub>	1 <sup>1</sup> / <sub>8</sub>	1 <sup>1</sup> / <sub>8</sub>	7 <sup>1</sup> / <sub>4</sub>	20 <sup>1</sup> / <sub>2</sub>	24 <sup>3</sup> / <sub>4</sub>	7	2 <sup>7</sup> / <sub>8</sub>	4 <sup>1</sup> / <sub>8</sub>	6 <sup>7</sup> / <sub>8</sub>	10 <sup>1</sup> / <sub>4</sub>	36°
RA-30-2	6000	2	17 <sup>1</sup> / <sub>4</sub>	1 <sup>1</sup> / <sub>4</sub>	1 <sup>11</sup> / <sub>16</sub>	6 <sup>7</sup> / <sub>8</sub>	20 <sup>1</sup> / <sub>2</sub>	24 <sup>3</sup> / <sub>4</sub>	7	2 <sup>7</sup> / <sub>8</sub>	4 <sup>1</sup> / <sub>8</sub>	7 <sup>1</sup> / <sub>4</sub>	9 <sup>7</sup> / <sub>8</sub>	36°
RA-30-3	9000	4 <sup>1</sup> / <sub>2</sub>	22	1 <sup>3</sup> / <sub>8</sub>	1 <sup>11</sup> / <sub>16</sub>	7 <sup>1</sup> / <sub>2</sub>	20 <sup>1</sup> / <sub>2</sub>	24 <sup>3</sup> / <sub>4</sub>	7	2 <sup>7</sup> / <sub>8</sub>	4 <sup>1</sup> / <sub>8</sub>	8 <sup>1</sup> / <sub>8</sub>	10 <sup>1</sup> / <sub>2</sub>	36°
RA-30-4	12000	6	22	1 <sup>3</sup> / <sub>4</sub>	1 <sup>11</sup> / <sub>16</sub>	8 <sup>1</sup> / <sub>2</sub>	20 <sup>1</sup> / <sub>2</sub>	24 <sup>3</sup> / <sub>4</sub>	7	2 <sup>7</sup> / <sub>8</sub>	4 <sup>1</sup> / <sub>8</sub>	9 <sup>3</sup> / <sub>4</sub>	11 <sup>1</sup> / <sub>2</sub>	36°

\* Hook throat opening with latch.

**Note:** Where clearance dimensions are critical, request certified print.

All dimensions are in inches unless otherwise indicated.

**G Model 3/4 - 15 Ton**

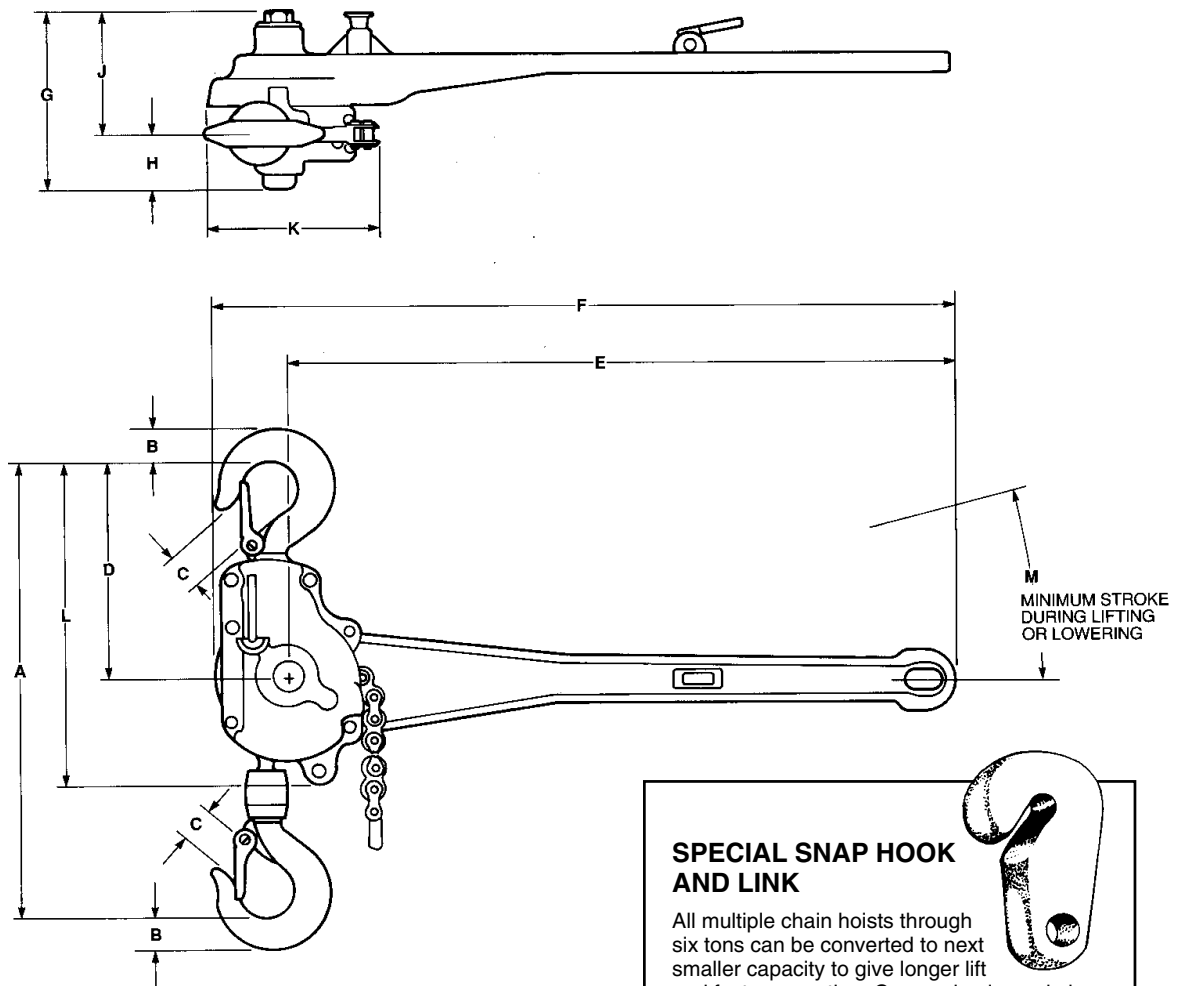

**SPECIAL SNAP HOOK AND LINK**

All multiple chain hoists through six tons can be converted to next smaller capacity to give longer lift and faster operation. Conversion is made by simply unhooking the special snap hook at the end of the chain. The snap hook acts as a lug and will not pass through the chain sprocket.



**Dimensions**

Model Number	A	B	C*	D	E	F	G	H	J	K	L	M
AG	13	1	1	6 <sup>1</sup> / <sub>4</sub>	18 <sup>3</sup> / <sub>4</sub>	20 <sup>3</sup> / <sub>4</sub>	5	1 <sup>1</sup> / <sub>2</sub>	3 <sup>1</sup> / <sub>2</sub>	4 <sup>1</sup> / <sub>2</sub>	9 <sup>1</sup> / <sub>4</sub>	60°
AGI <sup>1</sup>	13	1	1	6 <sup>1</sup> / <sub>4</sub>	18 <sup>3</sup> / <sub>4</sub>	20 <sup>3</sup> / <sub>4</sub>	5	1 <sup>1</sup> / <sub>2</sub>	3 <sup>1</sup> / <sub>2</sub>	4 <sup>1</sup> / <sub>2</sub>	9 <sup>1</sup> / <sub>4</sub>	30°
ATG <sup>2</sup>	15	1	1	6 <sup>1</sup> / <sub>4</sub>	18 <sup>3</sup> / <sub>4</sub>	20 <sup>3</sup> / <sub>4</sub>	5	1 <sup>1</sup> / <sub>2</sub>	3 <sup>1</sup> / <sub>2</sub>	4 <sup>1</sup> / <sub>2</sub>	9 <sup>1</sup> / <sub>4</sub>	60°
ATGI <sup>1, 2</sup>	15	1	1	6 <sup>1</sup> / <sub>4</sub>	18 <sup>3</sup> / <sub>4</sub>	20 <sup>3</sup> / <sub>4</sub>	5	1 <sup>1</sup> / <sub>2</sub>	3 <sup>1</sup> / <sub>2</sub>	4 <sup>1</sup> / <sub>2</sub>	9 <sup>1</sup> / <sub>4</sub>	30°
FG	16	1 <sup>1</sup> / <sub>8</sub>	1 <sup>1</sup> / <sub>8</sub>	7	27 <sup>5</sup> / <sub>8</sub>	29 <sup>7</sup> / <sub>8</sub>	6 <sup>1</sup> / <sub>4</sub>	1 <sup>3</sup> / <sub>4</sub>	4 <sup>1</sup> / <sub>2</sub>	5 <sup>3</sup> / <sub>4</sub>	10 <sup>1</sup> / <sub>4</sub>	60°
FGI <sup>1</sup>	16	1 <sup>1</sup> / <sub>8</sub>	1 <sup>1</sup> / <sub>8</sub>	7	27 <sup>5</sup> / <sub>8</sub>	29 <sup>7</sup> / <sub>8</sub>	6 <sup>1</sup> / <sub>4</sub>	1 <sup>3</sup> / <sub>4</sub>	4 <sup>1</sup> / <sub>2</sub>	5 <sup>3</sup> / <sub>4</sub>	10 <sup>1</sup> / <sub>4</sub>	30°
FTG <sup>3</sup>	17 <sup>5</sup> / <sub>8</sub>	1 <sup>1</sup> / <sub>8</sub>	1 <sup>1</sup> / <sub>8</sub>	7 <sup>3</sup> / <sub>8</sub>	27 <sup>5</sup> / <sub>8</sub>	29 <sup>7</sup> / <sub>8</sub>	6 <sup>1</sup> / <sub>4</sub>	1 <sup>3</sup> / <sub>4</sub>	4 <sup>1</sup> / <sub>2</sub>	5 <sup>3</sup> / <sub>4</sub>	10 <sup>5</sup> / <sub>8</sub>	60°
FTGI <sup>1, 3</sup>	17 <sup>5</sup> / <sub>8</sub>	1 <sup>1</sup> / <sub>8</sub>	1 <sup>1</sup> / <sub>8</sub>	7 <sup>3</sup> / <sub>8</sub>	27 <sup>5</sup> / <sub>8</sub>	29 <sup>7</sup> / <sub>8</sub>	6 <sup>1</sup> / <sub>4</sub>	1 <sup>3</sup> / <sub>4</sub>	4 <sup>1</sup> / <sub>2</sub>	5 <sup>3</sup> / <sub>4</sub>	10 <sup>5</sup> / <sub>8</sub>	30°
ZG-4 <sup>1</sup> / <sub>2</sub> <sup>4</sup> , ZG-6 <sup>5</sup>	25	1 <sup>13</sup> / <sub>16</sub>	1 <sup>11</sup> / <sub>16</sub>	8 <sup>1</sup> / <sub>4</sub>	33 <sup>5</sup> / <sub>8</sub>	36 <sup>1</sup> / <sub>8</sub>	6 <sup>1</sup> / <sub>8</sub>	1 <sup>11</sup> / <sub>16</sub>	4 <sup>7</sup> / <sub>16</sub>	6 <sup>1</sup> / <sub>8</sub>	12 <sup>7</sup> / <sub>8</sub>	60°
WG-9, WG-13 WG-11, WG-15	30	2 <sup>1</sup> / <sub>8</sub>	1 <sup>5</sup> / <sub>8</sub>	9 <sup>1</sup> / <sub>8</sub>	33 <sup>5</sup> / <sub>8</sub>	41 <sup>3</sup> / <sub>8</sub>	6 <sup>3</sup> / <sub>8</sub>	1 <sup>3</sup> / <sub>4</sub>	4 <sup>5</sup> / <sub>8</sub>	13 <sup>1</sup> / <sub>2</sub>	14 <sup>5</sup> / <sub>8</sub>	60°

<sup>1</sup>Double Pawls — can be operated with half strokes of lever for use in close quarters.

<sup>2</sup>Convertible model — 1 chain 3/4 ton, 112" lift. 2 chains 1 1/2 tons, 57" lift.

<sup>3</sup>Convertible model — 1 chain 1 1/2 tons, 112" lift. 2 chains 3 tons, 57" lift.

<sup>4</sup>Convertible model — 2 chain 3 tons, 76" lift. 3 chains 4 1/2 tons, 51" lift.

<sup>5</sup>Convertible model — 3 chain 4 1/2 tons, 70" lift. 4 chains 6 tons, 53" lift.

All dimensions are in inches unless otherwise indicated.

\*\*Minimum stroke on double locking pawl models (AGI, ATGI, FGI, FTGI) one-half (30°) that of single locking pawl models (AG, ATG, FG, FTG). Where clearance dimensions are critical, request certified print.



**Get a  
GRIP!**

## **WARRANTY**

**E**very Little Mule hoist is thoroughly inspected and performance tested prior to shipment from the factory. If any properly installed, maintained and operated hoist as outlined in the applicable accompanying Little Mule hoist manual develops a performance problem due to defective materials or workmanship as verified by Little Mule, repair or replacement of the hoist will be made to the original purchaser without charge and the hoist will be returned, transportation prepaid. This warranty does not apply where deterioration is caused by normal wear, abuse, improper or inadequate power supply,

improper or inadequate maintenance, eccentric or side loading, overloading, chemical or abrasive actions, excessive heat, unauthorized modifications or repairs, or use of non-Little Mule repair parts.

**EXCEPT AS STATED HEREIN, LITTLE MULE MAKES NO OTHER WARRANTIES, EXPRESSED OR IMPLIED, INCLUDING WARRANTIES OF MERCHANTABILITY AND FITNESS FOR A PARTICULAR PURPOSE.**

### **⚠ WARNING**

#### **Overloading and Improper Use Can Result In Injury**

**To Avoid Injury:**

- Do not exceed working load limit, load rating, or capacity.
- Do not use to lift people or loads over people.
- Use only alloy chain for overhead lifting.
- Read and follow all instructions.



**Little Mule Products** • Country Club Road • P.O. Box 779 • Wadesboro, North Carolina 28170 USA  
Tel: (800) 477-5003 • (704) 694-2156 • Fax: (800) 374-6853 • (704) 694-6829

E-Mail: [coffing@cmworks.com](mailto:coffing@cmworks.com) • [www.coffinghoists.com](http://www.coffinghoists.com)

©2003 Little Mule Products  
LMDB-1  
10M 07/03  
Printed In USA