



LMSC Ideal for Construction Field—Load Limiter Option Prevents Damaging Overloads

The industry's easiest-to-operate ratchet lever hoist just got better -- Little Mule LMSC Models are available with optional LOAD LIMITERS. Also featuring through-hardened load chain, these stamped steel ratchet lever hoists are lightweight, durable and are ideal for *construction and commercial* applications. All LMSC hoists are metric rated.



3/4 - 6 Ton

- **CAPACITIES & LIFT** - Rated loads of 3/4, 1 1/2, 3 and 6 tons, with 5, 10, 15 and 20 foot standard lifts. Other lifts available.
- **OPTIONAL LOAD LIMITER** - Load Limiter alerts operator of a possible overload by allowing the handle to rotate without lifting the higher-than capacity load. The load limiter can be field-installed.
- **RUGGED AND LIGHTWEIGHT** - Impact resistant, stamped steel housing withstands rigorous use. Compact design is portable and easy to rig.
- **LOW HANDLE EFFORT** - Double reduction gearing and short, cushioned-grip handle provide easy operation with minimal handle effort.
- **360° ROTATING HANDLE** - Provides versatile rigging options when used in confined spaces.
- **EASY FREE CHAINING** - State-of-the-art free wheeling mechanism allows quick and easy one-handed take-up and positioning of slack chain.
- **POSITIVE LOAD CONTROL** - Enclosed screw-and-disc type load brake stays clean and dry for positive load positioning. Latches on hooks provide positive load engagement.
- **LIFETIME WARRANTY**

SPECIFICATIONS

Model LMSC • 3/4 - 6 Ton

Capacity		Model Number	Lift (Ft.)	Strands of Load Chain	Minimum Distance Between Hooks (In.)	Handle Length (In.)	Average Handle Effort (Lbs.)	Net Weight (Lbs.)
Lbs.	Tons							
1500	3/4	LMSC-1500	5	1	11 ⁷ / ₈	9 ¹ / ₄	46	12
1500	3/4	LMSC-1510	10	1	11 ⁵ / ₈	9 ¹ / ₄	46	14
1500	3/4	LMSC-1515	15	1	11 ⁵ / ₈	9 ¹ / ₄	46	16
1500	3/4	LMSC-1520	20	1	11 ⁵ / ₈	9 ¹ / ₄	46	18
3000	1 1/2	LMSC-3000	5	1	13	14 ⁹ / ₁₆	59	21
3000	1 1/2	LMSC-3010	10	1	13	14 ⁹ / ₁₆	59	24
3000	1 1/2	LMSC-3015	15	1	13	14 ⁹ / ₁₆	59	27
3000	1 1/2	LMSC-3020	20	1	13	14 ⁹ / ₁₆	59	30
6000	3	LMSC-6000	5	1	16 ¹⁵ / ₁₆	14 ⁹ / ₁₆	75	35
6000	3	LMSC-6010	10	1	16 ¹⁵ / ₁₆	14 ⁹ / ₁₆	75	40
6000	3	LMSC-6015	15	1	16 ¹⁵ / ₁₆	14 ⁹ / ₁₆	75	45
6000	3	LMSC-6020	20	1	16 ¹⁵ / ₁₆	14 ⁹ / ₁₆	75	50
12000	6	LMSC-12000	5	2	22 ³ / ₄	14 ⁹ / ₁₆	76	67
12000	6	LMSC-12010	10	2	22 ³ / ₄	14 ⁹ / ₁₆	76	77
12000	6	LMSC-12015	15	2	22 ³ / ₄	14 ⁹ / ₁₆	76	88
12000	6	LMSC-12020	20	2	22 ³ / ₄	14 ⁹ / ₁₆	76	99

D I M E N S I O N A L D R A W I N G

Model LMSC

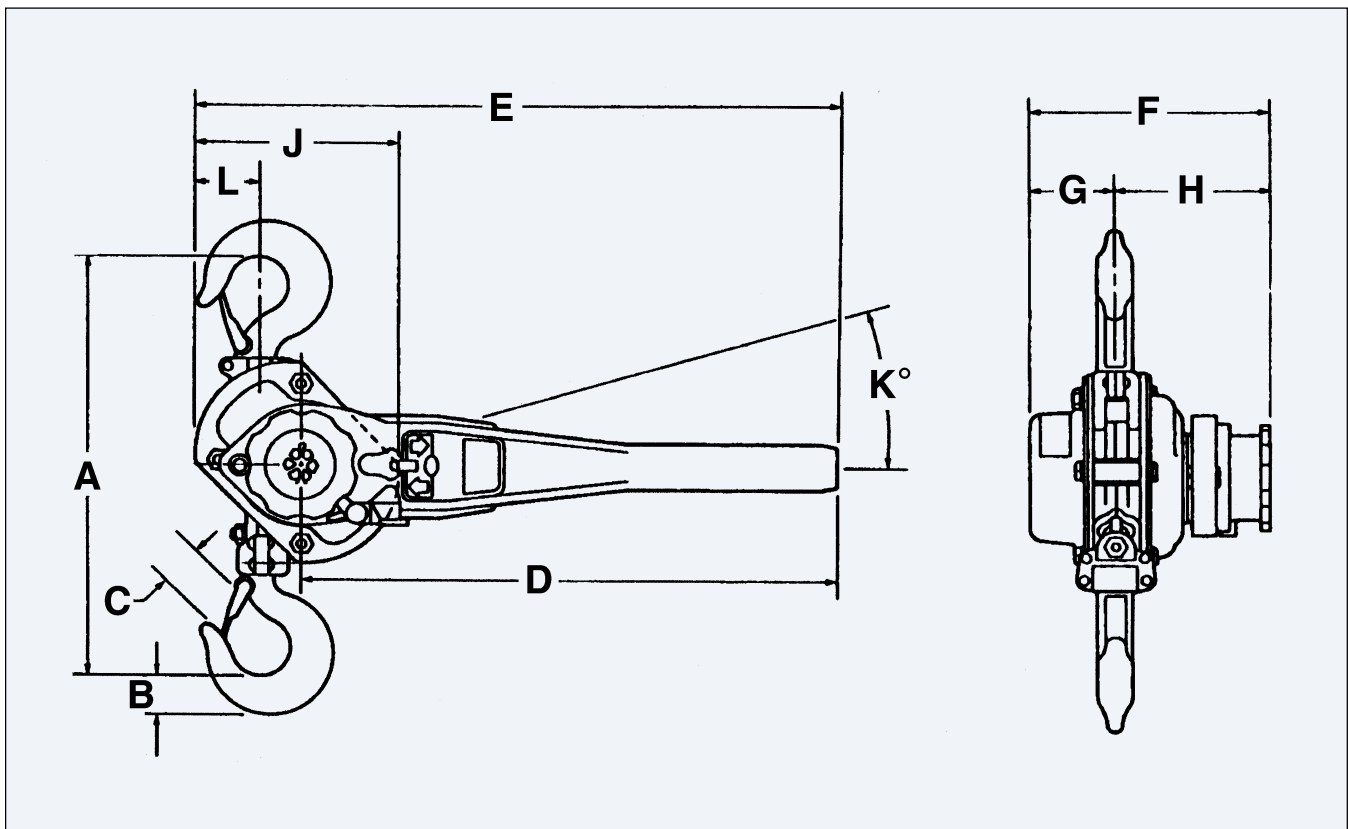

D I M E N S I O N S

All dimensions are in inches unless otherwise indicated.

Model No.	Rated Load (Lbs.)	A	B	C	D	E	F	G	H	J	K	L	No. of Load Chains
LMSC1500	1500	11 ⁵ / ₈	1 ³ / ₁₆	1 ⁵ / ₁₆	9 ¹ / ₄	11 ⁷ / ₁₆	5.59	2.06	3.54	4.72	9°	1.50	1
LMSC3000	3000	13	1 ¹ / ₁₆	1 ¹ / ₄	14 ⁹ / ₁₆	17	6.42	2.54	3.87	5.45	9°	1.62	1
LMSC6000	6000	16 ¹⁵ / ₁₆	1 ³ / ₈	1 ⁷ / ₃₂	14 ⁹ / ₁₆	18 ³ / ₁₆	7.28	3.22	4.03	7.00	9°	2.10	1
LMSC12000	12000	22 ³ / ₄	2 ¹ / ₁₆	1 ³ / ₄	14 ⁹ / ₁₆	20 ⁵ / ₁₆	7.28	3.22	4.03	10.20	9°	3.34	2



⚠ WARNING

Overloading and Improper Use Can Result In Injury

To Avoid Injury:

- Do not exceed working load limit, load rating, or capacity.
- Do not use to lift people or loads over people.
- Use only alloy chain and attachments for overhead lifting.
- Read and follow all instructions.

Products To Pull You Through The Tough Jobs



Country Club Road • PO Box 779
Wadesboro, NC 28170 USA

Phone: (800) 477-5003 (704) 694-2156

FAX: (800) 374-6853 (704) 694-6829

www.coffinghoists.com • e-mail: coffing@cmworks.com