

CB-22

# Model TB-602

High Performance Lifting

# COFFING<sup>®</sup> HOISTS

## This Handy Mini-Hoist Lifts Up to 550 Lbs. Convenient Toolbox Storage

The Coffing **TB-602** toolbox hoist is the most compact ratchet lever hoist in the market, performs just like the larger models, *plus* comes standard with these great features:

- Plated load chain is standard.
- Weston-type load brake.
- Rubber hand grip for better comfort and security.
- Lightweight design for ease of portability. Use in confined conditions with one-hand operation.
- Forged upper and lower hooks with latches standard.
- Impact resistant, all-steel frame, gear case and cover.
- Hardened link-type steel load chain for strength and long wear.
- Free wheeling feature serves to quickly attach the load.
- Metric rated.

**The  
Uses are  
Endless**

**Performs Just  
Like the Larger  
Hoists, but Small  
Enough to Fit in  
a Hard Hat**



**Model TB-602**

**550 Lb.  
Capacity**

**5 Ft. Lift  
Only**

**550 Lbs.**

### S P E C I F I C A T I O N S

Capacity (Lbs.)	Model Number	Product Code	Number of Chainfalls	Chain Dimensions d x t (In.)	Lift w/ One Full Lever Turn (In.)	Handle Pull @ W.L.L. (Lbs.)	Net Weight w/ Standard Lift (Lbs.)
550 Lbs.	TB-602	0210	1	.16 x .47	3.15	56.2	6.0

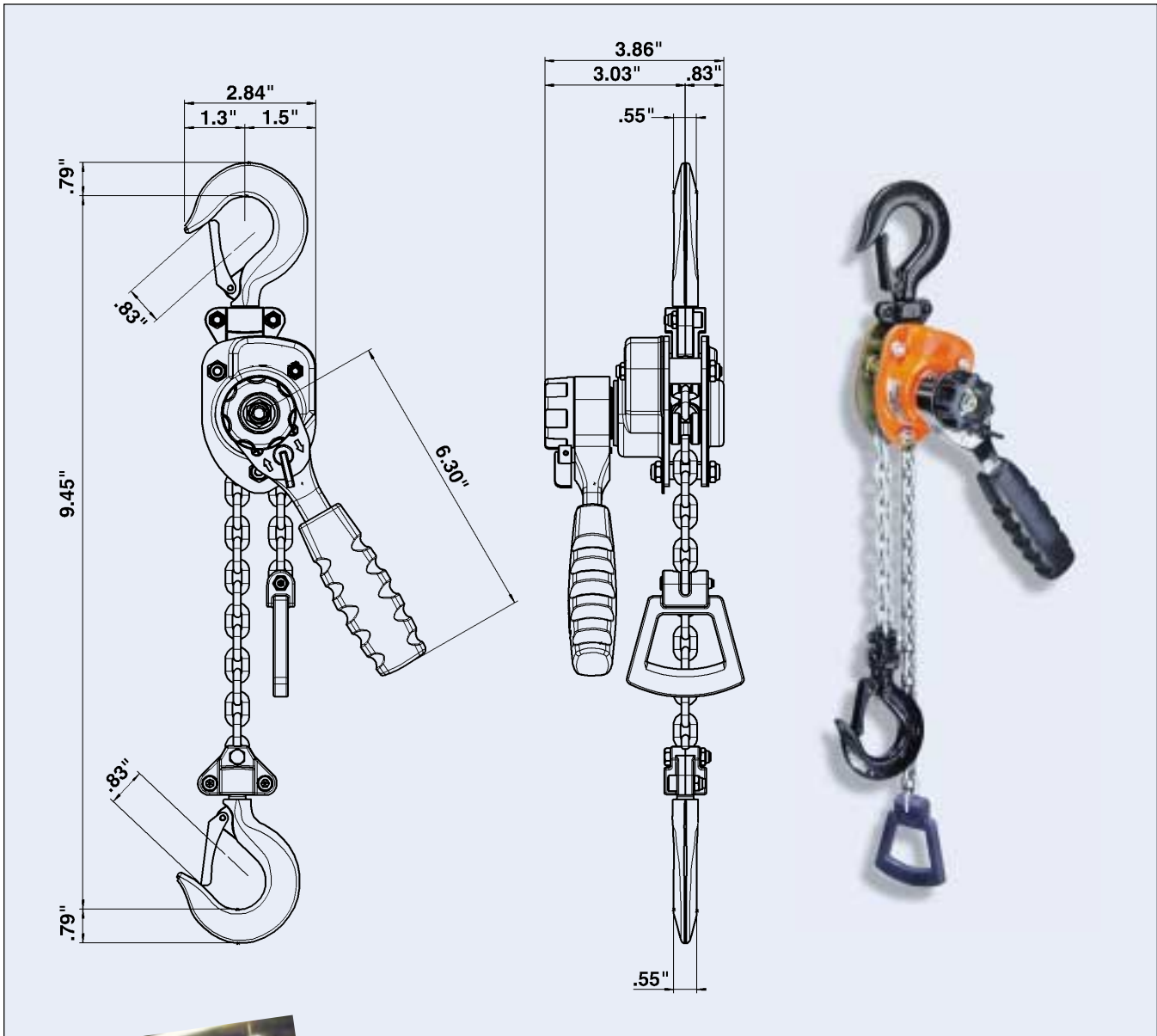

**⚠ WARNING**

Overloading and Improper Use Can Result In Injury

To Avoid Injury:

- Do not exceed working load limit, load rating, or capacity.
- Do not use to lift people or loads over people.
- Use only alloy chain and attachments for overhead lifting.
- Read and follow all instructions.

*High Performance Lifting*

**COFFING®**  
**HOISTS**

Country Club Road • PO Box 779  
Wadesboro, NC 28170 USA

Phone: (800) 477-5003 (704) 694-2156  
FAX: (800) 374-6853 (704) 694-6829

[www.coffinghoists.com](http://www.coffinghoists.com) e-mail: [coffing@cmworks.com](mailto:coffing@cmworks.com)