

High Performance Lifting

COFFING® HOISTS

Heavy Duty, Plain or Geared Trolleys — Industrial Grade, Superior Performance

The Coffing **CYA Trolleys** are designed for heavy duty service with fully sealed, precision bearings, heavy-duty side plates, and machined wheel tread provide superior performance and long life with minimal maintenance.

- **Capacities** - Available in capacities ranging from 4 through 25 ton; with 30, 40 and 50 ton trolleys available as tandem construction.
- **Dual Tread** - 4 through 12 ton capacity trolleys have dual tread wheels for standard and wide flange beams.
- **Bearings** - Trolleys are equipped with eight sealed, Timken tapered roller bearings and grease fittings.
- **Side Frames** - Heavy rolled steel frames extend beyond the wheels to act as bumpers.
- **Wheels Keep On Rolling** - Trolley wheels are machined from cast iron alloy and hardened for high strength and long life.
- **Swinging Chain Guide** - Geared versions have fully machined track wheel gears and incorporate a swinging chain guide, which keeps the hand chain aligned and free from jamming.
- **Requirements** - Consult factory for additional beam sizes and patented track applications.
- **Made In USA**



S P E C I F I C A T I O N S

4 - 25 Ton

Capacity (Tons)	Product Code Number		Beam Height (In.)	Flange Width (In.)	Minimum Radius Curve (In.)	Net Weight (Lbs.)	
	Plain	Geared				Plain	† Geared
4	1641-0400	1642-0400	8 - 24	4.00 - 7.00	36	155	184
5	1641-0500	1642-0500	8 - 24	4.00 - 7.00	36	160	188
6	1641-0600	1642-0600	8 - 24	4.00 - 7.00	36	160	180
8	1641-0800	1642-0800	10 - 24	4.63 - 8.00	60	300	347
10	1641-1000	1642-1000	10 - 24	4.63 - 8.00	60	310	360
12	1641-1200	1642-1200	10 - 24	4.63 - 8.00	60	310	360
16	1631-1600	1632-1600	18 - 24	6.00 - 8.00	96	800	895
20	1631-2000	1632-2000	18 - 24	6.00 - 8.00	96	845	955
25	1631-2500	1632-2500	18 - 24	6.00 - 8.00	120	1045	1200

For wide flange beam adaptation, patented track or for beams larger than standard - consult factory.

Specify curve on order. Wheels are modified to negotiate curves. **8 Ft. standard hand chain drop on geared trolley.**

† Weight less hand chain.

DIMENSIONAL DRAWING

Model CYA

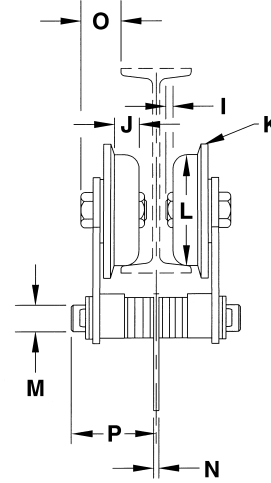
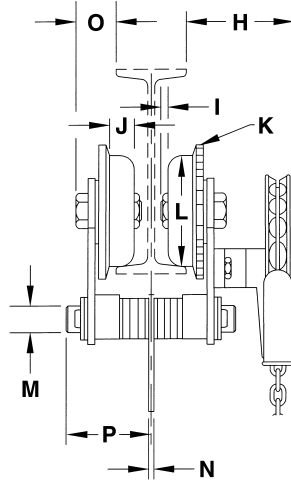
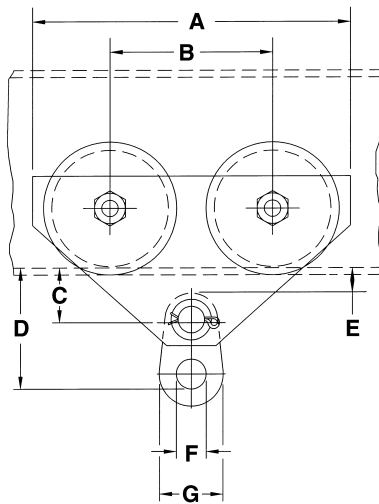

GEARED

PLAIN

CLEARANCE DIMENSIONS (In.)

Cap. (Tons)	A	B	C	D	E	F	G	H	I	J	K	L	M	N	O	P
4	18 ³ / ₄	8 ¹ / ₂	3 ¹ / ₄	8 ³ / ₈	1 ¹ / ₄	2 ³ / ₄	4 ³ / ₄	8 ¹ / ₈	1 ¹ / ₈	1 ³ / ₈	8	6 ³ / ₈	2	5 ⁵ / ₈	2 ⁵ / ₈	6 ¹ / ₈
5	18 ³ / ₄	8 ¹ / ₂	3 ¹ / ₄	8 ⁵ / ₈	1 ¹ / ₄	3	5 ¹ / ₂	8 ¹ / ₈	1 ¹ / ₈	1 ³ / ₈	8	6 ³ / ₈	2	5 ⁵ / ₈	2 ⁵ / ₈	6 ¹ / ₈
6	18 ³ / ₄	8 ¹ / ₂	3 ¹ / ₄	8 ⁵ / ₈	1 ¹ / ₄	3	5 ¹ / ₂	8 ¹ / ₈	1 ¹ / ₈	1 ³ / ₈	8	6 ³ / ₈	2	5 ⁵ / ₈	2 ⁵ / ₈	6 ¹ / ₈
8	23 ⁵ / ₈	10 ⁵ / ₈	3 ⁷ / ₈	10 ⁵ / ₈	1 ³ / ₈	3 ¹ / ₂	6 ¹ / ₂	9	1 ¹ / ₈	1 ¹¹ / ₁₆	10	8 ¹ / ₄	2 ¹ / ₂	3 ³ / ₄	3 ¹ / ₄	6 ⁷ / ₈
10	23 ⁵ / ₈	10 ⁵ / ₈	3 ⁷ / ₈	11 ¹ / ₈	1 ³ / ₈	4 ¹ / ₂	8	9	1 ¹ / ₈	1 ¹¹ / ₁₆	10	8 ¹ / ₄	2 ¹ / ₂	1	3 ¹ / ₄	6 ⁷ / ₈
12	23 ⁵ / ₈	10 ⁵ / ₈	3 ⁷ / ₈	11 ¹ / ₈	1 ³ / ₈	4 ¹ / ₂	8	9	1 ¹ / ₈	1 ¹¹ / ₁₆	10	8 ¹ / ₄	2 ¹ / ₂	1	3 ¹ / ₄	6 ⁷ / ₈
16	28 ¹ / ₄	14	5 ⁷ / ₈	15 ¹ / ₄	2 ¹ / ₂	4	9	14 ¹ / ₂	5 ⁵ / ₁₆	2	13 ¹ / ₂	11 ³ / ₄	3 ¹ / ₄	1 ¹ / ₂	7	8
20	28 ¹ / ₄	14	5 ⁷ / ₈	16 ⁵ / ₈	2 ¹ / ₂	4	10	14 ¹ / ₂	5 ⁵ / ₁₆	2	13 ¹ / ₂	11 ³ / ₄	3 ¹ / ₄	1 ³ / ₄	7	8 ¹ / ₄
25	28 ¹ / ₄	14	5 ⁷ / ₈	16 ³ / ₄	2 ¹ / ₈	4	10	14 ¹ / ₂	5 ⁵ / ₁₆	2	13 ¹ / ₂	11 ³ / ₄	3 ¹ / ₄	1 ³ / ₄	7	8 ¹ / ₄

Notes: All dimensions are in inches.
 Wheels with convex treads are standard on all capacities.
 20, 25, 30 and 40 ton trolleys can be furnished in tandem construction - 30 and 40 ton dimensions furnished upon application.

* Dimensions shown are for minimum beam size and will vary proportionately for larger beams.

⚠ WARNING

Overloading and Improper Use Can Result In Injury

- To Avoid Injury:**
- Do not exceed working load limit, load rating, or capacity.
 - Do not use to lift people or loads over people.
 - Use only alloy chain and attachments for overhead lifting.
 - Read and follow all instructions.

High Performance Lifting

COFFING®

HOISTS

Country Club Road • PO Box 779
 Wadesboro, NC 28170 USA

Phone: (800) 477-5003 (704) 694-2156

FAX: (800) 374-6853 (704) 694-6829

www.coffinghoists.com e-mail: coffing@cmworks.com