

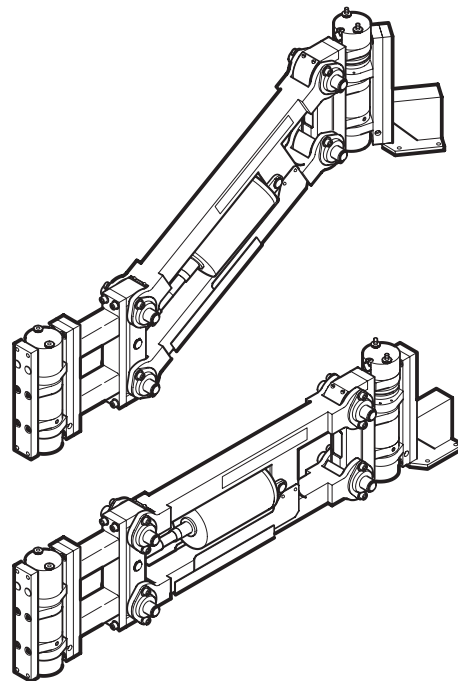

PARTS, OPERATION AND MAINTENANCE MANUAL for MEDIUM DUTY TOOL ARM

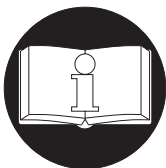

(Dwg. MHP1717)



READ THIS MANUAL BEFORE USING THESE PRODUCTS. This manual contains important safety, installation, and maintenance information. Make this manual available to all persons responsible for the operation, installation and maintenance of these products.

! WARNING

This equipment is intended for industrial use only and should not be used for lifting, supporting, or transporting people or lifting or supporting loads over people.

Always operate, inspect and maintain this unit in accordance with applicable safety codes and regulations.

Refer all communications to the nearest Ingersoll-Rand Material Handling Office or Distributor.

SAFETY INFORMATION

This manual provides important information for all personnel involved with the safe installation, operation and proper maintenance of this product. Even if you feel you are familiar with this or similar equipment, you should read this manual before operating the product.

Danger, Warning, Caution and Notice

Throughout this manual there are steps and procedures which, if not followed, may result in a hazard. The following signal words are used to identify the level of potential hazard.

DANGER

Danger is used to indicate the presence of a hazard which **will** cause **severe** injury, death, or substantial property damage if the warning is ignored.

WARNING

Warning is used to indicate the presence of a hazard which **can** cause **severe** injury, death, or substantial property damage if the warning is ignored.

CAUTION

Caution is used to indicate the presence of a hazard which **will** or **can** cause injury or property damage if the warning is ignored.

NOTICE

Notice is used to notify people of installation, operation, or maintenance information which is important but not hazard-related.

Safety Summary

Personal protective and safety equipment must be used and maintained in accordance with the manufacturer's instructions. The Tool Arm should not be left suspended when not in use, lower the tool to the floor or a suitable location.

WARNING

- **Do not use this unit or attached equipment for lifting, supporting, or transporting people or lifting or supporting loads over people.**
- **The supporting structures and load-attaching devices used in conjunction with these units must provide a safety factor of at least three times the rated capacity of the unit. This is the customer's responsibility. If in doubt, consult a registered structural engineer.**
- **If system air pressure is lost, lower the tool immediately. Operator's must stay out of the vertical path of the tool.**

NOTICE

- **Lifting and handling equipment is subject to different regulations in each country. These regulations may not be specified in this manual.**

Employees who work near suspended loads or assist in positioning or arranging a load should be instructed to keep out from under the load. From a safety standpoint, one factor is paramount: conduct all lifting and positioning operations in such a manner that if there were an equipment failure, no personnel would be injured. This means keep out from under a raised tool and keep out of the intended path of the tool.

It is the owner's and user's responsibility to determine the suitability of a product for any particular use. It is recommended that all applicable industry, trade association, federal, state and local regulations be checked. Read all operating instructions and warnings before operation.

This manual has been produced by **Ingersoll-Rand** to provide dealers, mechanics, operators and company personnel with the information required to install, operate, maintain and repair the products described herein.

It is extremely important that mechanics and operators be familiar with the servicing procedures of these products, or like or similar products, and are physically capable of conducting the procedures. These personnel shall have a general working knowledge that includes:

1. Proper and safe use and application of mechanic's common hand tools as well as special **Ingersoll-Rand** or recommended tools.
2. Safety procedures, precautions and work habits established by accepted industry standards.

Ingersoll-Rand cannot know of, or provide all the procedures by which product operations or repairs may be conducted and the hazards and/or results of each method. If operation or maintenance procedures not specifically recommended by the manufacturer are conducted, it must be ensured that product safety is not endangered by the actions taken. If unsure of an operation or maintenance procedure or step, personnel should place the product in a safe condition and contact supervisors and/or the factory for technical assistance.

SAFE OPERATING INSTRUCTIONS

The following warnings and operating instructions are intended to avoid unsafe operating practices which might lead to injury or property damage.

Ingersoll-Rand recognizes that most companies using this type of equipment have a safety program in force at their facility. If you are aware that some conflict exists between a rule set forth in this publication and a similar rule already set by an individual company, the more stringent of the two should take precedence.

This manual supports a fully installed system. Operators should be familiar with the operation of the unit before use.

Safe Operating Instructions are provided to make an operator aware of dangerous practices to avoid and are not necessarily limited to the following list. Refer to specific sections in the manual for additional safety information.

1. Only allow personnel trained in, safety and operation on this product to operate and maintain the system.
2. Only operate unit if you are physically fit to do so.
3. When a “**DO NOT OPERATE**” sign is placed on the system, do not operate the unit until the sign has been removed by designated personnel.
4. Before each shift, check the unit for wear and damage. Never use a unit that inspection indicates is worn or damaged.
5. Never exceed the tool capacity of the unit.
6. Be certain the tool holder and tool extension are properly secured.
7. Pay attention to the tool at all times when operating the unit.
8. Make sure everyone is clear of the tool arm path. Do not operate over people.
9. Never use the unit for lifting or lowering people, and never allow anyone to stand on the tool holder.
10. Never weld or cut on components connected to the unit.
11. Shut off air supply before performing any maintenance.
12. Use good posture when operating the system.
13. Check air connections for leakage.

SPECIFICATIONS

Description

The Tool Arm is designed in modular sections which can be assembled to suit specific applications. When these sections are assembled as a group they maximize interaction between man and machine.

The Tool Arm can be mounted to an overhead or vertical structure depending on application requirements.

Assembly	Length		Height		Width		Weight	
	inches	mm	inches	mm	inches	mm	lbs	kg
Parallel Link Arm	27.2	690	10.5	266	4.6	117	28.7	13
Pivot	4.7	120	10.7	274	2.9	75	7.5	3.4
Pivot Brake	3.1	78	3.0	77			2.2	1
Extension (120 mm)	4.7	120	10.4	265	2.0	50	3.88	1.76
Extension (500 mm)	19.7	500					6.4	2.9
Extension (1000 mm)	39.4	1000					9.7	4.4
Adapter Plate	4.7	120	11.0	280	3.9	100	2.9	1.3

Material	Anodized Aluminum	
Maximum Weight at end of Parallel Link Arm	66 lbs	30 kg
Maximum Torque Reaction	110 ft lbs	150 Nm
Single Parallel Link Arm maximum vertical range	20 inches	500 mm
Pivot rotational range	110° either side of center	

Typical Tool Arm Configurations

Maximum Pivot Rotation

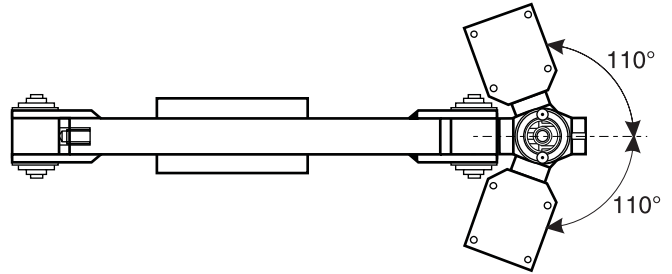
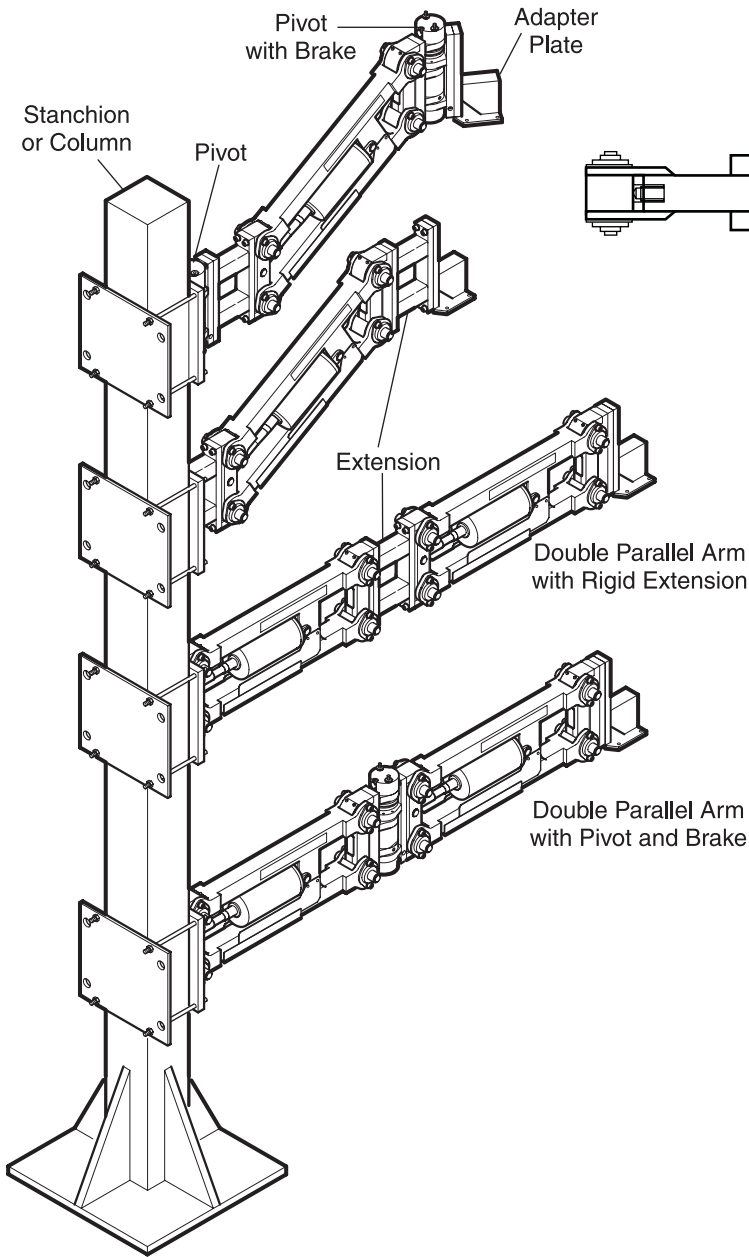

(Dwg. MHP1829)

(Dwg. MHP1742)

INSTALLATION

Prior to installing the unit, carefully inspect it for possible shipping damage.

⚠ CAUTION

- Owners and users are advised to examine specific, local or other regulations, including American National Standards Institute and/or OSHA Regulations which may apply to a particular type of use of this product before installing or putting the unit into use.
- Before installing, read “SAFETY INFORMATION”.

Ensure the unit is properly installed. A little extra time and effort in doing so can contribute a lot toward preventing accidents, injuries and will help achieve the best service possible.

NOTICE

- Lubrication of the Tool Arm is not recommended.

Ensure mounting structure and hardware provide adequate support to handle all anticipated loads. The Tool Arm must be capable of moving within its designated range without interfering with surrounding equipment and allow safe traffic flow of personnel and equipment in the area.

Mounting The Unit

Ensure the supporting member to which the Tool Arm is attached is strong enough to support the weight of the unit plus the weight of any attached optional components and a maximum rated tool load plus a generous factor of at least 300% of the combined weights. If in doubt, contact a registered structural engineer.

Ensure the installation area provides adequate room to safely operate the Tool Arm and attached components throughout the complete range of motion.

The Tool Arm may be mounted to a stationary foundation, beam, or vertical structure. Consult a registered structural engineer to determine a suitable installation configuration.

Ensure the Tool Arm is mounted to provide operators with the most ergonomically efficient operating range.

Air System

An air supply system is required for all Tool Arms. The air supply is connected to the cylinder and may be utilized for brake and, if suitable, for tool operation.

The supply air must be clean and free from water, water vapor and oil. 6.9 bar/690 kPa (100 psi) at the unit is required to provide rated capacity. Do not exceed 6.9 bar/690 kPa (100 psi).

⚠ WARNING

- Do not use an air line lubricator of any kind. Oil may damage internal components.

Check tool manufacturer’s specifications for correct air supply requirements.

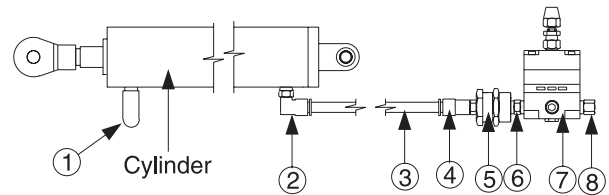

(Dwg. MHP1747)

Air System Parts List

Item No.	Description of Parts	Total Qty.	Part No.
*	Cylinder	1	58252222
1	Breather, Vent	1	58255175
2	Fitting, Elbow	1	58255142
3	Tube	1	58255159
4	Fitting, Tube Connector	1	58255126
5	Bulkhead	1	58255167
6	Fitting, Connector	1	58254582
7	BA Regulator	1	13830
8	Fitting *	1	58255134

* An elbow fitting, as shown in Dwg. MHP1831 on page 6 may be substituted.

Air Lines

The inside diameter of the air supply lines should not be smaller than 6 mm (1/4 inch) based on a maximum of 30 metres (100 feet) between the air supply and the unit. Contact the factory for recommended air line sizes for distances greater than 30 metres (100 feet). Before making final connections, all air supply lines should be purged. Supply lines should be as short and straight as installation conditions will permit. Long transmission lines and excessive use of fittings, elbows, tees, globe valves, etc. cause a reduction in pressure due to restrictions and surface friction in the lines. If quick-disconnect fittings are used at the inlet of the unit, they must have at least a 6 mm (1/4 inch) air passage. Use of smaller fittings may affect performance.

Air Line Filter

It is recommended that a filter/regulator package be used. Refer to “OPTIONS, ATTACHMENTS AND ACCESSORIES” section.

The air line strainer/filter should be installed as close as practical to the Tool Arm. The strainer/filter should provide 5 micron filtration and include a moisture trap. Clean the strainer/filter monthly to maintain its operating efficiency.

To maintain dry air, the frequency for draining the filter should also be based on the condition of the air supply. It is recommended that the filter be drained weekly at first. Depending on air supply condition, a proper filter drain schedule should be established.

Moisture in Air Lines

Moisture that reaches the Tool Arm and associated components through the supply lines is the chief factor in determining the length of time between service overhauls. Moisture traps can help to eliminate moisture. Other methods, such as an air receiver which collects moisture before it reaches the unit, or an aftercooler at the compressor that cools air prior to distribution through the supply lines are also helpful.

Attaching the Tool Holder

Refer to Dwg. MHP1699 or MHP1702 on page 18. Attach the tool holder to the lower flange of the tool bracket or tool extension using four capscrews, washers, nuts and two clamping plates. To position tool holder, loosen capscrews and rotate until desired position is achieved. Retighten capscrews. Torque fasteners to 30 Nm (22 ft lbs). Install tool in tool holder and tighten capscrews to clamp tool into position.

Air Cylinder

Parallel Link Arm assemblies are pre-assembled with the air cylinder. If it becomes necessary to replace the air cylinder refer "MAINTENANCE" section.

Brake (optional feature)

The brake assembly mounts on top of the swivel assembly. Connect 4 mm air hose to elbow fittings shown in Dwg. MHP1797 on page 6. Minimum pressure 5 bar (72 psi) and maximum pressure 10 bar (145 psi). Brake operation can be accomplished using a typical 5/2 pneumatic valve (not provided with brake option).

To apply the brake: supply air to the upper connector and port lower fitting to exhaust.

To release the brake: supply air to the lower fitting and port upper fitting to exhaust.

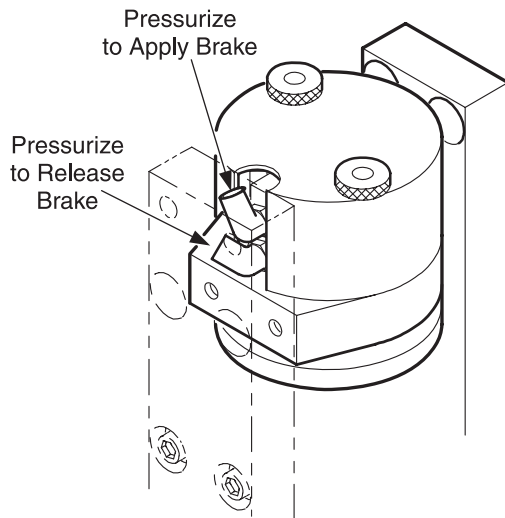

(Dwg. MHP1797)

Adjustments

Prior to operating the Tool Arm, but after installation, ensure the following adjustments, as they apply to your assembly and optional components, are made:

1. If necessary, adjust air regulator as described in this section. Refer to "Regulator Installation" and "Operational Adjustments".
2. Adjust pivot stops to suit application requirements. Refer to "MAINTENANCE" section.

Regulator Installation

Refer to Dwgs. MHP1831 on page 6 and MHP1747 on page 5.

The regulator should be installed between fittings (2) and (3). The check valve (8) must be threaded into the fitting (3), which is threaded into the regulator input. Refer to Dwg. MHP1747 on page 5. A tube must be connected between fitting (2) and elbow fitting on the air cylinder. Ensure flow direction is correct.

NOTICE

• **The arrow on the check valve (8) must be pointing towards the cylinder. If check valve is installed backwards, the cylinder will not function.**

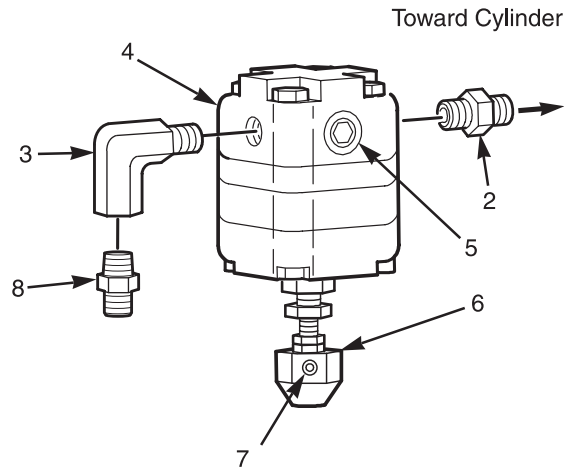

(Dwg. MHP1831)

Regulator Parts List

Item No.	Description of Parts	Qty. Total	Part No.
1	Regulator Assembly (Includes items 2 through 8)	1	13825
2	Fitting, Connector	1	10731
3	Fitting, Elbow	1	10375
4	Regulator	1	13830
5	Plug	2	10764
6	Control Knob	1	13832
7	Setscrew	1	13833
8	Check Valve	1	13270

Operational Adjustments

To establish a "zero gravity" condition for the operator to manipulate the tool, complete the following adjustment procedures:

⚠ WARNING

• **Prior to performing operational adjustments, or servicing, ensure air supply is off and unit is not under load.**

1. Turn adjustment knob (6) counterclockwise until unit stops.
2. Attach tool to unit. This will require the tool be installed in the tool holder. Connect coiled air tube.
3. Turn on air supply.
4. Turn the adjustment knob clockwise until the tool begins to move. The regulator is properly set when equal effort is required to raise and lower the tool.
5. Tighten locknut on regulator stem to lock adjustment in position.

OPERATION

The four most important aspects of operation are:

1. Follow all safety instructions when operating the unit.
2. Only allow people trained in safety and operation of this product to operate the unit.
3. Subject each unit to a regular inspection and maintenance program.
4. Be aware of the unit range and capacity at all times.

Ensure operators use suitable personnel protective equipment when operating Tool Arms and attached tools. Maintain personnel protective equipment in accordance with manufacturer's instructions.

At the end of each shift, or prior to turning off air supply, lower tool to its lowest position.

Description Of Operation

The Tool Arm is an integrated group of components designed to maximize the interaction of man and machine. Ease of operation minimizes operator fatigue and incorporates added safety during the performance of repetitive tasks.

Principles Of Operation

The Tool Arm is designed to allow vertical and/or horizontal (plane) operational control within a specific range of motion. During travel ensure the tool travel path is clear and pay attention to the direction of travel during movement.

Vertical raising and lowering of the tool should be easily accomplished by exerting force on the tool. Use the tool to move side to side and raise or lower the Tool Arm.

Tool Holder (optional feature)

Two Tool Holder designs are available.

Fixed Horizontal/Vertical (Two Axis):

To reposition tool either loosen tool clamp capscrews to rotate tool in holder, or loosen the four mounting capscrews to rotate complete tool holder assembly. Tighten capscrews when correct adjustment is obtained.

360° Tool Holder (Three Axis):

To rotate a tool held in tool holder, pull out plunger and rotate to desired position. Allow plunger to spring return to locked position. Rotate tool slightly to engage the locking pin. The tool holder may also be rotated by loosening the four mounting capscrews to rotate complete tool holder assembly. Tighten capscrews when correct adjustment is obtained.

Brake (optional feature)

To apply the brake depress the brake activation button.

To release the brake depress the brake release button.

In the event of air loss, the brake can be released by carefully loosening one of the brake line fittings. This should allow any trapped air to vent releasing the brake.

⚠ WARNING

- All new, altered or repaired equipment should be inspected and tested by personnel instructed in safety, operation and maintenance of this equipment to ensure safe operation at rated specifications before placing equipment in service.
- Never use a unit that inspection indicates is damaged.

The inspection intervals recommended in this manual are based on intermittent operation of the equipment eight hours each day, five days per week, in an environment relatively free of dust, moisture and corrosive fumes. If the equipment is operated almost continuously, or more than eight hours each day, more frequent inspections will be required.

Frequent and periodic inspections should be performed on equipment in regular service. Frequent inspections are visual examinations performed by operators or personnel trained in safety and operation of this equipment and include observations made during routine equipment operation. Periodic inspections are thorough inspections conducted by personnel trained in the safety, operation and maintenance of this equipment. Inspection intervals depend upon the nature of the critical components of the equipment and the severity of usage.

Careful inspection on a regular basis will reveal potentially dangerous conditions while still in the early stages, allowing corrective action to be taken before the condition becomes dangerous.

Deficiencies revealed through inspection, or noted during operation, must be reported to designated personnel instructed in safety, operation and maintenance of this equipment. A determination as to whether a condition constitutes a safety hazard must be made, and the correction of noted safety hazards accomplished and documented by written report before placing the equipment in service.

Records and Reports

Inspection records, listing all points requiring periodic inspection should be maintained for all load bearing equipment. Written reports, based on severity of service, should be made on the condition of critical parts as a method of documenting periodic inspections. These reports should be dated, signed by the person who performed the inspection, and kept on file where they are readily available for authorized review.

Frequent Inspections

For equipment in continuous service, frequent inspections should be made by operators at the beginning of each shift.

1. OPERATION. Check for visual signs or abnormal movement which could indicate a potential problem. Ensure Tool Arm and tool movements are smooth and unrestricted.
2. FASTENERS. Ensure fasteners are secure. Tighten loose and replace damaged fasteners.
3. TOOL HOLDER (optional feature). On 360° Tool Holders check tool holder clamps are not damaged. Check tool holder rotates freely and locking mechanism provides positive stop.
4. AIR SYSTEM. Visually inspect all connections, fittings, hoses and components for indication of air leaks. Repair any leaks or damage, tighten any loose connections.

Periodic Inspection

Frequency of periodic inspection depends on the severity of usage:

NORMAL	HEAVY	SEVERE
yearly	semiannually	quarterly

Disassembly may be required for HEAVY or SEVERE usage. Keep cumulative written records of periodic inspections to provide a basis for continuing evaluation.

Inspect all the items in "Frequent Inspection". Also inspect the following:

1. FASTENERS. Verify fasteners are tight. Torque fasteners to recommended torque levels.
2. AIR CYLINDER. Check cylinder vent is clean and unrestricted. Check cylinder for leaks and external damage. Replace or repair cylinder as required.
3. TOOL EXTENSION (optional feature). Check for wear and damage. Repair or replace as necessary.
4. PIVOT ASSEMBLY. Check Tool Arm pivots freely and limit stops are correctly adjusted. Refer to "MAINTENANCE" section for adjustments and repair information.
5. BRAKE ASSEMBLY. Check brake locks when brake is activated. Refer to "MAINTENANCE" section for adjustments and repair information.
6. GUARDS. Check guards are in good condition and fasteners are secure.

INSPECTION AND MAINTENANCE REPORT

Ingersoll-Rand

Tool Arm

Model Number:	Date:
	Inspected By:
Reason for Inspection: (Check Applicable Box)	
	1. Scheduled Periodic Inspection: _____ Quarterly _____ Semiannually _____ Yearly
	2. Discrepancies noted during Frequent Inspection
	3. Discrepancies noted during Maintenance
	4. Other: _____
Operating Environment: Normal _____ Heavy _____ Severe _____	

Refer to the Parts, Operation and Maintenance Manual "INSPECTION" section for general inspection criteria. Also, refer to appropriate National Standards and codes of practice. If in doubt about an existing condition, contact the nearest **Ingersoll-Rand** Distributor or the factory for technical assistance.

COMPONENT	CONDITION		CORRECTIVE ACTION		NOTES
	Pass	Fail	Repair	Replace	
Fasteners			---		
Bearings			---		
Pivot Pins			---		
Brake			---		
Tool Extension					
Supporting Structure					
Bushings			---		
Labels and Tags			---		
Air Cylinder					
Tool Holder					
Guards and Covers					
Air System					
Other Components (list in NOTES section)					

This page may be photocopied and used as an Inspection/Maintenance record.

TROUBLESHOOTING

This section provides basic troubleshooting information. Determination of specific causes to problems are best identified by thorough inspections performed by personnel instructed in safety, operation and maintenance of this equipment. The chart below provides a brief guide to possible problems and remedies.

Component	Problem	Remedy
Pivot Assembly	Movement is not smooth, or may be binding.	Inspect pivot assembly. Repair or replace as necessary to ensure pivot assembly movement is smooth and does not bind.
	Fasteners are loose.	Ensure fasteners are tightened to rated torque specifications.
	Pivot rotation angle is incorrect.	Adjust pivot rotation stops. Refer to "MAINTENANCE" section.
Control Hoses	Hose leaks at fittings or along length of hose.	Replace worn, leaking or damaged hoses and fittings.
	Hose binding at connections.	Ensure swivel connections operate correctly without sticking or binding. Replace fittings that stick or bind.
Brake Assembly	Arm does not pivot.	Brake is not releasing. Check pressure is exhausting from brake.
	Return spring may be damaged.	Replace spring.
	Brake does not activate.	Check brake piston for air leaks.
Cylinder	Effort to extend or retract Tool Arm is not equal.	Check regulator adjustment. Refer to "INSTALLATION" section.
		Check cylinder vent is clean and unrestricted.

MAINTENANCE

⚠ CAUTION

- Use of replacement parts other than genuine Ingersoll-Rand parts could result in damage to the unit and void the warranty.

⚠ WARNING

- Never perform maintenance on the Tool Arm while it is supporting a tool.
- Before performing maintenance, tag controls:
DANGER - DO NOT OPERATE - EQUIPMENT BEING REPAIRED.
- Only allow service personnel trained in safety and maintenance on this unit to perform maintenance.
- After performing any maintenance on the unit, adjust and test unit in specified application before returning to service.
- Shut off air system and depressurize air lines before performing any maintenance.

Maintenance Intervals

The Maintenance Interval chart is based on intermittent operation of the unit eight hours each day, five days per week. If unit operation exceeds eight hours per day, or use is under HEAVY or SEVERE conditions, more frequent maintenance should be performed. Refer to 'Periodic Inspection' in the "INSPECTION" section for interval guidance.

INTERVAL	MAINTENANCE CHECK
Start of each shift (Operator or Maintenance Personnel)	Make a thorough visual inspection of the Tool Arm and attached components for damage. Do not operate the unit, or components, if damaged. Operate the unit through the normal range of movements. Unit must operate smoothly without sticking, binding or abnormal noises.
3 Months (Maintenance Personnel)	Check brake operation. Clean or replace parts as required.
Yearly (Maintenance Personnel)	Inspect pivot assembly. Check all the supporting members, including the clamps, fasteners, nuts, cylinder, tool holder, etc. for indications of damage or wear. Repair or replace as required.

Adjustments

Regulator

Refer to "INSTALLATION" section for regulator adjustment.

Pivot Stops

Remove nuts (44) and cap (63) from the lower side of the swivel assembly. Loosen capscrews (61) in adjustment stop rings (59) and position tool for required operating range. Pins (60) will contact stop plate (58) to limit travel range. Torque capscrews to 6 Nm (4.4 ft lbs) and recheck range.

Reinstall cap (63), aligning holes with threaded rods (62), and secure with nuts (44).

Disassembly

Parallel Link Arm Disassembly

1. Lower parallel link arm.
2. Disconnect airline to cylinder (25), optional brake assembly (70), if installed, and tool. Remove retainer rings (4) from pins (27) and (20). Remove pivot assembly (40) and extensions (90) from parallel link arm.
3. Remove pins (27) and (20) and lift out cylinder.
4. Remove retainer rings (4) from pins (3) and carefully tap out pins.
5. Separate upper and lower arms from supports (2) and (26).
6. Remove capscrews (5) and washers (6) from bearings (7).
7. Remove bearings from arms.
8. **DO NOT** remove guards (22) unless they are damaged and must be replaced.

Brake Disassembly

1. Remove nuts (44) and cover (71).
2. Remove capscrews (42) and washers (43) that secure brake support (75) to support plate (54).
3. Remove brake support (75) complete with brake assembly.
4. Remove spring (80), cap screw (78), washer (77) and gear pinion (76).
5. Remove four capscrews (72) and lift off piston assembly (73).
6. Remove capscrews (82) and ring gears (81) and (83).

Pivot Disassembly

1. Remove nuts (44) and top cover (46) on units without a brake, or follow brake disassembly instructions for units with a brake.
2. Remove nuts (44) and lower cap (63).
3. Loosen capscrews in adjustment stop rings (59) and slide stop rings from pivot shaft (48).
4. Remove capscrews (42) and lockwashers (43) from support plates (41) and (54). Remove support plates.
5. Remove stop plate (58) from support plate (41).
6. Tap pin (56) out of center support (55) and pivot shaft (48).
7. Remove support plates and spacer (53) from pivot shaft (48).
8. Press bushings (50) out of support plates if they require replacement.

Cleaning, Inspection and Repair

Examine disassembled components and fasteners for wear or damage. If worn or damaged, do not reuse. During reassembly all damaged and worn components should be replaced to prevent component failure which may result in injury or property damage.

It is recommended that lockwashers be discarded and replaced with new ones after each use.

Use the following procedures to clean, inspect and repair the Tool Arm and associated components.

Cleaning

Thoroughly clean all Tool Arm components in solvent. The use of a stiff bristle brush will facilitate the removal of accumulated dirt and sediments on the columns. Wipe off each part after cleaning. Remove all old Loctite® residue.

Inspection

All disassembled parts should be inspected to determine their fitness for continued use. Pay particular attention to the following:

1. Inspect all threaded items and replace those having damaged threads.
2. Inspect all bearings for freeness of rotation and wear. Replace bearings if rotation is rough or bearings are worn.
3. Optional Pivot Assembly: inspect pivot assembly bushings. Replace worn bushings.
4. Optional Brake Assembly: inspect brake ring gears and pinion gear for damaged or worn gear teeth. Replace worn or damaged parts.
5. Inspect stop ring pins and stop plate for damage. Replace if worn or deformed.
6. Inspect all pivot pins for wear. Replace pins that are scored or worn.

Repair

Actual repairs are limited to the removal of small burrs and other minor surface imperfections. Use a fine stone or emery cloth for this work.

1. Worn or damaged parts must be replaced. Refer to the parts section for specific replacement parts information.
2. Inspect all remaining parts for evidence of wear or damage. Replace or repair any part which is in questionable condition. The cost of the part is often minor in comparison with the cost of redoing the job.
3. When fastening components, always use Loctite® 243 on capscrew threads.

Assembly

Parallel Link Arm Assembly Procedure

1. Ensure guards (22) are secure and not damaged.
2. Install bearings (7) at both end of each arm. Loosely secure with capscrews (5) and washers (6).
3. Assemble upper and lower arms to the end supports (2) and (26). Locate with pins (3).
4. Install retainer rings (4) to secure pins.
5. Torque capscrews (5) to 20 Nm (14.8 ft lbs) only after upper and lower arms, bearings and pins are assembled. This will allow proper alignment and avoid binding the bearings.
6. Position cylinder (25) between parallel arms and align rod end and cylinder end with locating pin holes in the parallel arm section.
7. Install pins (20) and (27) and secure in location with retainer rings (4).

Brake Assembly Procedure

1. Mount the lower ring gear (83) to the top support plate on the pivot assembly and secure with capscrews (82). Torque capscrews to 2 Nm (1.5 ft lbs).
2. Position second ring gear (81) to brake support plate (75) and align dowel pins (79). Secure with capscrews (82). Torque capscrews to 2 Nm (1.5 ft lbs).
3. Position piston assembly (73) on brake support plate, use capscrews (72) as a guide. Install pinion gear on opposite side and secure with washer (77) and capscrew (78).
4. Install spring (80) and mount assembly on pivot assembly. Torque capscrews (72) to 6 Nm (4.4 ft lbs).
5. Install capscrews (42) and washers (43) through support plate to secure brake assembly.
6. Install cover (71) and secure with nuts (44).

Pivot Assembly Procedure

1. Install bushings (50) in support plates. Ensure bushing flanges are correctly located. Drill pin hole through bushing wall for pin (56). Use flange hole as a guide.
2. Install pins (52) in support plates (28) and (31).
3. Assemble support plates on pivot shaft (48) with cover (53). Ensure bushing (50) flanges are toward each other.
4. Install center cross pin (56) to locate center support plate (55).
5. Install the stop plate (58) in side frame (41). Use Loctite® 243 on threads and torque to 6 Nm (4.4 ft lbs).
6. Assemble side frames (41) and (54) to support plates and secure with capscrews (42) and lockwashers (43). Use Loctite® 243 on threads and torque to 60 Nm (44.2 ft lbs).
7. Assemble support plates (26) and (34) with pivot shaft (25). Assemble side frame (21) to support plates (26) and (34) with capscrews (22). Use Loctite® 243 on capscrew threads and torque to 195 Nm (144 ft lbs).
8. Install pin (60) in adjustment stop rings (59) and install adjustment stop rings on pivot shaft (48). Lightly torque capscrews (61) to clamp. Adjustments will be made after assembly.
9. Install bushing (24) on pivot shaft (25). Engagement is only partial on pivot shaft. Bushing is not required if brake is not used.
10. Install spacer screws (62) in support plate (57) and install cover (63). Secure with nuts (44).
11. Adjust pivot stops as described in the "Adjustments" section on page 6.

Testing

Prior to initial use, all new, altered or repaired Tool Arms shall be tested to ensure proper operation.

1. Check Tool Arm movement through full operational range. Ensure movement is smooth and without binding. Ensure there are no obstructions through the operating range.
2. Ensure all guards are in place and undamaged.
3. Install tool expected to be used. Check position and regulator adjustments.
4. Check operation of optional brake, if installed. Ensure brake activates and releases in response to control operation.

PARTS ORDERING INFORMATION

The Tool Arm is designed and constructed to provide long, trouble-free service. In time it may become necessary to order and install new parts to replace those that have been subjected to wear.

The use of replacement parts other than genuine **Ingersoll-Rand** Material Handling may result in decreased performance, and may, at the company's option invalidate the warranty. For prompt service and genuine **Ingersoll-Rand** Material Handling parts, provide your nearest Distributor with the following:

1. Complete unit model number, or description.
2. Part number and part description as shown in this manual.
3. Quantity required.

For your convenience and future reference it is recommended that the following information be recorded:

Model Description _____

Date Purchased _____

Return Goods Policy

Ingersoll-Rand will not accept any returned goods for warranty or service work unless prior arrangements have been made and written authorization has been provided from the location where the goods were purchased.

NOTICE

• **Continuing improvement and advancement of design may produce changes to this unit which are not included in this manual. Manuals are periodically revised to incorporate changes. Always check the manual edition number on the front cover for the latest issue.**

Disposal

When the life of the unit has expired, it is recommended that the unit be disassembled, degreased and parts separated as to materials so that they may be recycled.

For additional information contact:

**Ingersoll-Rand Material Handling
Zimmerman Handling Systems**
29555 Stephenson Highway
Madison Heights, MI 48071-2387
Phone: (248) 398-6200
Fax: (248) 398-1374

or

**Ingersoll-Rand Material Handling
Douai Operations**
111, avenue Roger Salengro
59450 Sin Le Noble, France
Phone: (33) 3-27-93-08-08
Fax: (33) 3-27-93-08-00

For additional information on the following products order the publication by the referenced Part/Document Number listed:

Publication	Part/Document Number	Publication	Part/Document Number
Light Duty Tool Arm	MHD56174	Z-Rail System	MHD56159
Torque Tube	MHD56172	Valu-Trak Rail System	MHD56161

TOOL ARM ASSEMBLY PARTS DRAWING

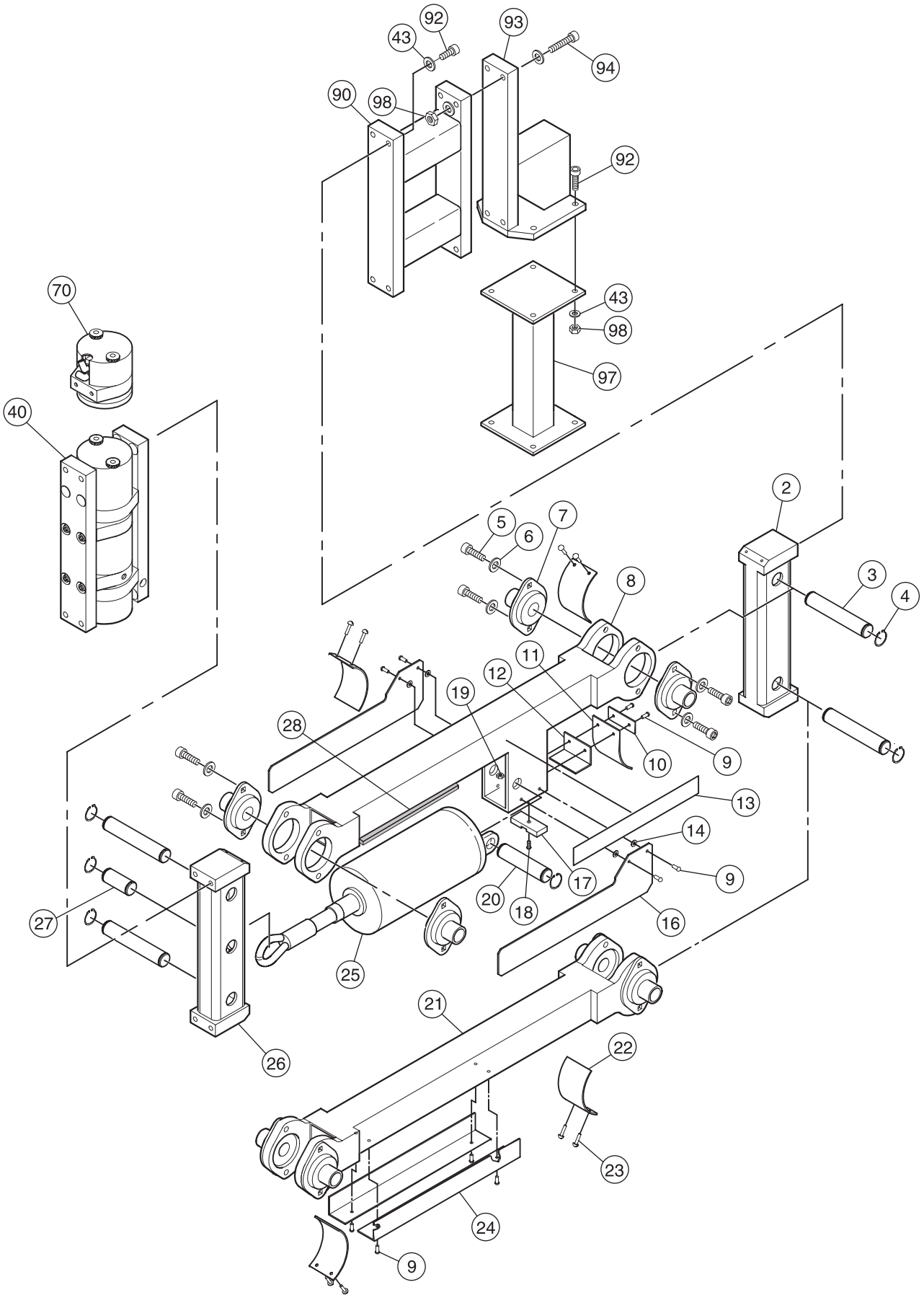

(Dwg. MHP1713)

TOOL ARM ASSEMBLY PARTS LIST

Item No.	Description of Part	Qty. Total	Part Number
1	Parallel Link Arm Assembly (includes items 2 through 27)	1	58252479
2	Support	1	58252651
3	Pin	4	58252677
4	Retainer Ring	10	58252271
5	Capscrew (M8 x 16)	16	58252255
6	Washer (M8)	16	58252289
7	Bearing	8	58252214
8	Arm (Upper)	1	58252610
9	Rivet	12	58253576
10	Plate	1	58253873
11	Shield	1	58253899
12	Bracket	1	58253865
13	Ingersoll-Rand Label	1	54065420
14	Spacer Washer	4	58253565
16	Guard	2	58253535
17	Plate	1	58253832
18	Capscrew	1	58253915
19	Nut	1	58253923
20	Pin with retainers (included with item 25)	1	- - -
21	Arm (Lower)	1	58252560
22	Cover	4	58253352
23	Rivet	8	58252297
24	Bracket	2	58253543
25	Cylinder (includes item 20)	1	58252222
26	Support	1	58252669
27	Pin	1	58253345
28	Foam Pad	2	58254285
40	Pivot Assembly (Refer to page 17)	-	58252487
43	Washer (M10)	As Req'd	58253394
70	Brake Assembly	-	58252495
90	Extension (120 mm Long shown)	As Req'd	*
92	Capscrew (M10 x 40)	As Req'd	58254053
93	90° Adapter Plate	1	58252503
94	Capscrew (M10 x 50)	4	58254160
97	Tool Extension	As Req'd	*
98	Nut (M10)	As Req'd	58250747

* Refer to "OPTIONS, ATTACHMENTS AND ACCESSORIES" on page 18.

OPTIONAL BRAKE AND PIVOT ASSEMBLY PARTS DRAWING

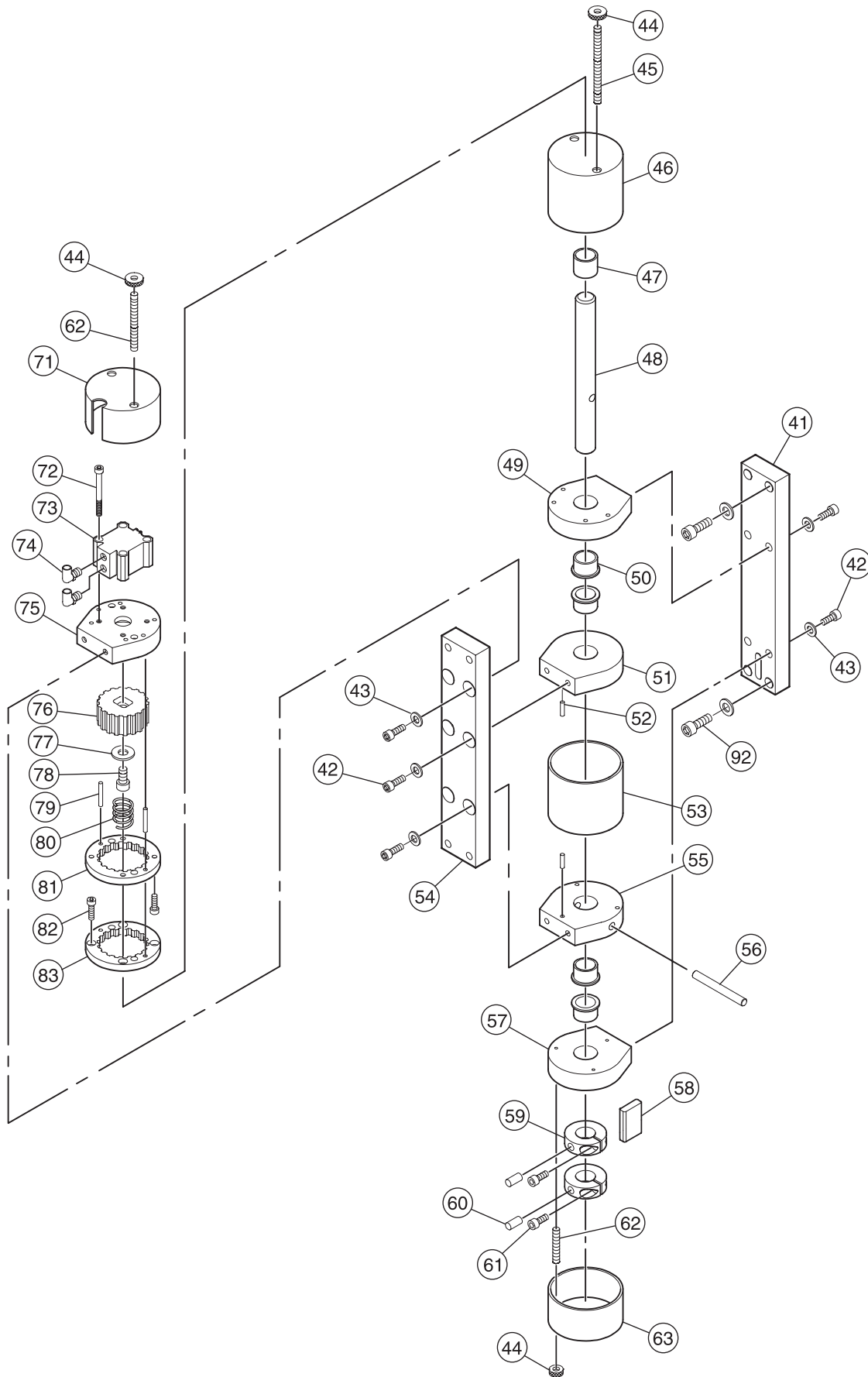

(Dwg. MHP1816)

OPTIONAL BRAKE AND PIVOT ASSEMBLY PARTS LIST

Item No.	Description of Part	Qty. Total	Part Number
40	Pivot Assembly (includes items 41 through 63)	1	58252487
41	Support Plate	1	58253295
42	Capscrew (M10 x 20, 12.9)	8 (10 with brake)	58252321
43	Washer (M10)	12 (14 with brake)	58253394
44	Nut (M4)	4	58253410
45	Threaded Rod (M4 x 86 mm long)	2	58253428
46	Cover (not required when brake is used)	1	58253253
47	Bushing (Straight)	1	58252313
48	Pivot Shaft	1	58253279
49	Support	1	58253337
50	Bushing (Flanged)	4	58252305
51	Support	1	58253329
52	Pin	4	58253386
53	Sleeve	1	58253246
54	Support Plate	1	58253287
55	Support	1	58253303
56	Pin	1	58253360
57	Support	1	58253311
58	Stop Plate	1	58253451
59	Adjustment Stop Ring	2	58253469
60	Pin	2	58254939
61	Capscrew	2	Contact Factory
62	Threaded Rod (M4 x 50 mm long)	2	58253436
63	Cap	1	58253261
70	Brake Assembly (includes items 44, 45 and 71 through 83)	1	58252495
44	Nut (M4)	2	58253410
62	Threaded Rod (M4 x 86 mm long)	2	58253436
71	Cap	1	58253261
72	Capscrew (M5 x 35, 8.8)	4	58253790
73	Brake Piston	1	58252438
74	Fitting, Elbow	2	58253824
75	Support, Brake	1	58253493
76	Gear Pinion	1	58252446
77	Washer	1	58252289
78	Capscrew (M8 x 16, 12.9)	1	58253808
79	Pin	8	58253816
80	Spring	1	58253857
81	Ring Gear (Upper)	1	58252453
82	Capscrew (M4 x 20, 12.9)	8	58253782
83	Ring Gear (Lower)	1	58252461
92	Capscrew (M10-40, 12.9)	4	58254053

OPTIONS, ATTACHMENTS AND ACCESSORIES

Tool Holder

Item Number	Part Number *	Description	Weight	
			lbs	kg
100	52000	Fixed horizontal/vertical	2	0.9
	52100	360 degree (Three Axis) swivel	5	2.27

* Must order one of the extension tubes. Refer to Extension Tubes listed below.

Accepts tools from 19 to 63 mm (3/4 to 2-1/2 inch) diameter.

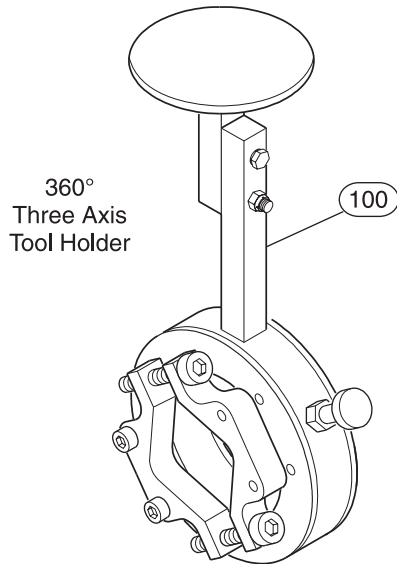

(Dwg. MHP1699)

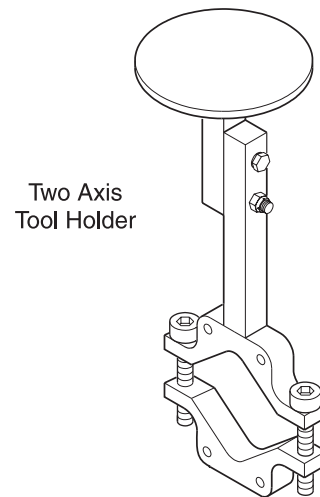

(Dwg. MHP1702)

Arm Extension

Item Number	Part Number	Length		Weight	
		inch	mm	lbs	kg
90	58254194 *	4.7	120	Contact Factory	
	58252735	19.7	500	6.4	2.9
	58252750	39.4	1000	9.7	4.4

* Required to connect two parallel arms and is the same length as a pivot section.

Tool Extension Tubes

Item Number	Part Number	Length		Weight	
		inch	mm	lbs	kg
97	50150	5.9	150	2.7	1.2
	50300	11.8	300	3.9	1.8
	50450	17.7	450	5.1	2.3
	50600	23.6	600	6.3	2.9
	50750	29.5	750	7.5	3.4
	50900	35.4	900	8.7	3.9

Accessories

Part Number	Description
90014	Tool air supply package 1/4 inch
B18-02-FKG0-28	Filter/Regulator 1/4 inch Compact Series
B18-03-FKG0-28	Filter/Regulator 3/8 inch Compact Series
B18-04-FKG0-28	Filter/Regulator 1/2 inch Compact Series

Limited Warranty

Ingersoll-Rand Company (I-R) warrants to the original user its Products to be free of defects in material and workmanship for a period of one year from the date of purchase. **I-R** will repair, without cost, any Product found to be defective, including parts and labor charges, or at its option, will replace such Products or refund the purchase price less a reasonable allowance for depreciation, in exchange for the Product. Repairs or replacements are warranted for the remainder of the original warranty period.

If any Product proves defective within its original one year warranty period, it should be returned to any Authorized Hoist and Winch Service Distributor, transportation prepaid with proof of purchase or warranty card.

This warranty does not apply to Products which **I-R** has determined to have been misused or abused, improperly maintained by the user, or where the malfunction or defect can be attributed to the use of non-genuine **I-R** parts.

I-R makes no other warranty, and all implied warranties including any warranty of merchantability or fitness for a particular purpose are limited to the duration of the expressed warranty period as set forth above. I-R's maximum liability is limited to the purchase price of the Product and in no event shall I-R be liable for any consequential, indirect, incidental, or special damages of any nature rising from the sale or use of the Product, whether based on contract, tort, or otherwise.

Note: Some states do not allow limitations on incidental or consequential damages or how long an implied warranty lasts so that the above limitations may not apply to you.

This warranty gives you specific legal rights and you may also have other rights which may vary from state to state.

Important Notice

It is our policy to promote safe delivery of all orders. This shipment has been thoroughly checked, packed and inspected before leaving our plant and receipt for it in good condition has been received from the carrier. Any loss or damage which occurs to this shipment while en route is not due to any action or conduct of the manufacturer.

Visible Loss or Damage

If any of the goods called for on the bill of lading or express receipt are damaged or the quantity is short, do not accept them until the freight or express agent makes an appropriate notation on your freight bill or express receipt.

Concealed Loss or Damage

When a shipment has been delivered to you in apparent good condition, but upon opening the crate or container, loss or damage has taken place while in transit, notify the carrier's agent immediately.

Damage Claims

You must file claims for damage with the carrier. It is the transportation company's responsibility to reimburse you for repair or replacement of goods damaged in shipment. Claims for loss or damage in shipment must not be deducted from the **Ingersoll-Rand** invoice, nor should payment of **Ingersoll-Rand** invoice be withheld awaiting adjustment of such claims as the carrier guarantees safe delivery.

You may return products damaged in shipment to us for repair, which services will be for your account and form your basis for claim against the carrier.

United States Office Locations

Technical Support contact: **Regional Sales Offices**

**Ingersoll-Rand
Zimmerman Handling
Systems**
29555 Stephenson Highway
Madison Heights, MI
48071-2387

Phone: (248) 398-6200
Fax: (248) 398-1374

For Order Entry, Order Status and Technical Support contact:

**Ingersoll-Rand
Material Handling
Douai Operations**
111, avenue Roger Salengro
59450 Sin Le Noble, France
Phone: (33) 3-27-93-08-08
Fax: (33) 3-27-93-08-00

Web Site:
www.ingersoll-rand.com

Chicago, IL
888 Industrial Drive
Elmhurst, IL 60126
Phone: (630) 530-3800
Fax: (630) 530-3891

Detroit, MI
23192 Commerce Drive
Farmington Hills, MI 48335
Phone: (248) 476-6677
Fax: (248) 476-6670

Houston, TX
450 Gears Road
Suite 210
Houston, TX 77067-4516
Phone: (281) 872-6800
Fax: (281) 872-6807

Los Angeles, CA
11909 E. Telegraph Road
Santa Fe Springs, CA
90670-0525
Phone: (562) 948-4189
Fax: (562) 948-1828

Philadelphia, PA
P.O. Box 425
900 E. 8th Ave., Suite 103
King of Prussia, PA 19406
Phone: (610) 337-5930
Fax: (610) 337-5912

International Office Locations

Offices and distributors in principal cities throughout the world. Contact the nearest **Ingersoll-Rand** office for the name and address of the distributor in your country or write/fax to:

**Ingersoll-Rand
Zimmerman Handling
Systems**
29555 Stephenson Highway
Madison Heights, MI
48071-2387
Phone: (248) 398-6200
Fax: (248) 398-1374

**Canada
National Sales Office
Regional Warehouse
Toronto, Ontario**
51 Worcester Road
Rexdale, Ontario
M9W 4K2
Phone: (416) 213-4500
Fax: (416) 213-4510
Order Desk
Fax: (416) 213-4506

**Regional Sales Offices
Edmonton, Alberta**
1430 Weber Center
5555 Calgary Trail N.W.
Edmonton, Alberta
T6H 2P9
Phone: (403) 438-5039
Fax: (403) 437-3145

Montreal, Quebec
3501 St. Charles Blvd.
Kirkland, Quebec
H9H 4S3
Phone: (514) 695-9040
Fax: (514) 695-0963

British Columbia
1200 Cliveden Avenue
Delta, B.C.
V3M 6G4
Phone: (604) 523-0803
Fax: (604) 523-0801

**Latin America Operations
Ingersoll-Rand
Production Equipment Group**
730 N.W. 107 Avenue
Suite 300, Miami, FL USA
33172-3107
Phone: (305) 559-0500
Fax: (305) 222-0864

**Europe, Middle East and
Africa
Ingersoll-Rand
Material Handling
Douai Operations**
111, avenue Roger Salengro
59450 Sin Le Noble, France
Phone: (33) 3-27-93-08-08
Fax: (33) 3-27-93-08-00

**Asia Pacific Operations
Ingersoll-Rand Asia Pacific Inc.**
Suite 1201-3, 12/F
Central Plaza
18 Harbour Road
Wanchai, Hong Kong
Phone: (852) 9794 1673
Fax: (852) 9794 7895

**Russia
Ingersoll-Rand**
Kuznetsky Most 21/5
Entrance 3
Moscow 103895 Russia
Phone: 7-501-923-91-34
Fax: 7-501-924-46-25