

PARTS, OPERATION AND MAINTENANCE MANUAL for BUNDLE HANDLER

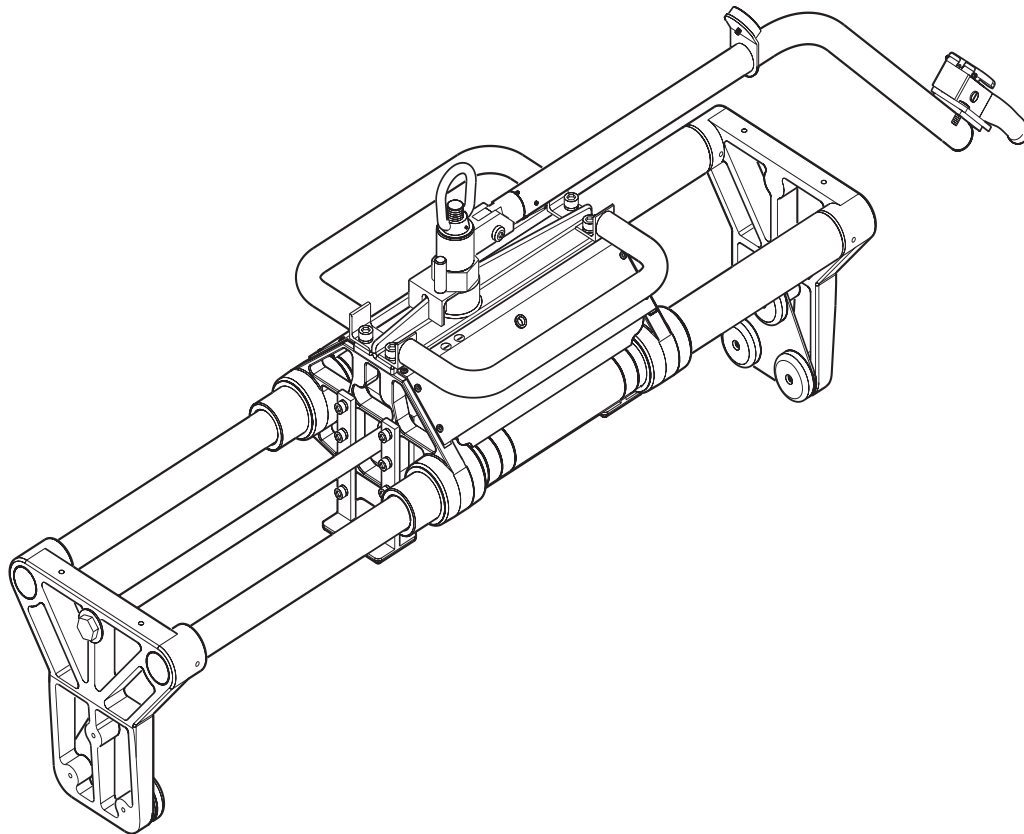

(Dwg. MHP2184)



READ THIS MANUAL BEFORE USING THESE PRODUCTS. This manual contains important safety, installation, operation and maintenance information. Make this manual available to all persons responsible for the installation, operation and maintenance of these products.

⚠ WARNING

This equipment is intended for industrial use only and should not be used for lifting, supporting, or transporting people or lifting or supporting loads over people.

Always operate, inspect and maintain this unit in accordance with applicable safety codes and regulations.

Form MHD56227
Edition 1
June, 2002
71374391
© 2002 Ingersoll-Rand Company



SAFETY INFORMATION

This manual provides important information for all personnel involved with the safe installation, operation and proper maintenance of this product. Even if you feel you are familiar with this or similar equipment, you should read this manual before operating the product.

Danger, Warning, Caution and Notice

Throughout this manual there are steps and procedures which, if not followed, may result in a hazard. The following signal words are used to identify the level of potential hazard.

DANGER

Danger is used to indicate the presence of a hazard which **will** cause **severe** injury, death, or substantial property damage if the warning is ignored.

WARNING

Warning is used to indicate the presence of a hazard which **can** cause **severe** injury, death, or substantial property damage if the warning is ignored.

CAUTION

Caution is used to indicate the presence of a hazard which **will** or **can** cause injury or property damage if the warning is ignored.

NOTICE

Notice is used to notify people of installation, operation, or maintenance information which is important but not hazard-related.

Safety Summary

Personal protective and safety equipment should be used and maintained in accordance with the manufacturer's instructions.

WARNING

- **Do not use this unit or attached equipment for lifting, supporting, or transporting people or lifting or supporting loads over people.**
- **The supporting structures and load-attaching devices used in conjunction with these units must provide a safety factor of at least three times the rated capacity of the unit. This is the customer's responsibility. If in doubt, consult a registered structural engineer.**
- **If system air pressure is lost, lower the load immediately. The operator must stay out of the vertical path of the load.**

NOTICE

- **Lifting equipment is subject to different regulations in each country. These regulations may not be specified in this manual.**

Employees who work near suspended loads or assist in positioning or arranging a load should be instructed to keep out from under the load. From a safety standpoint, one factor is paramount: conduct all lifting operations in such a manner that if there were an equipment failure, no personnel would be injured. This means keep out from under a raised load and keep out of the line of force of any load.

It is the owner's and user's responsibility to determine the suitability of a product for any particular use. It is recommended that all applicable industry, trade association, federal, state and local regulations be checked. Read all operating instructions and warnings before operation.

This manual has been produced by **Ingersoll-Rand** to provide dealers, mechanics, operators and company personnel with the information required to install, operate, maintain and repair the products described herein.

It is extremely important that mechanics and operators be familiar with the servicing procedures of these products, or like or similar products, and are physically capable of conducting the procedures. These personnel shall have a general working knowledge that includes:

1. Proper and safe use and application of mechanics common hand tools as well as special **Ingersoll-Rand** or recommended tools.
2. Safety procedures, precautions and work habits established by accepted industry standards.

Ingersoll-Rand cannot know of, or provide all the procedures by which product operations or repairs may be conducted and the hazards and/or results of each method. If operation or maintenance procedures not specifically recommended by the manufacturer are conducted, it must be ensured that product safety is not endangered by the actions taken. If unsure of an operation or maintenance procedure or step, personnel should place the product in a safe condition and contact supervisors and/or the factory for technical assistance.

SAFE OPERATING INSTRUCTIONS

The following warnings and operating instructions are intended to avoid unsafe operating practices which might lead to injury or property damage.

Ingersoll-Rand recognizes that most companies who use material handling equipment have a safety program in force at their facility. If you are aware that some conflict exists between a rule set forth in this publication and a similar rule already set by an individual company, the more stringent of the two should take precedence.

The manual supports a fully installed system. Operators should be familiar with the operation of the controls before using the system.

Safe Operating Instructions are provided to make an operator aware of dangerous practices to avoid and are not necessarily limited to the following list. Refer to specific sections in the manual for additional safety information.

1. Only allow personnel trained in, safety and operation on this product to operate and maintain the system.
2. Only operate bundle handler if you are physically fit to do so.
3. When a **“DO NOT OPERATE”** sign is placed on the system, do not operate the bundle handler until the sign has been removed by designated personnel.
4. Before each shift, check the system for wear and damage. Never use a bundle handler that inspection indicates is worn or damaged.
5. Never lift a load greater than the rated capacity of the bundle handler. Refer to **“SPECIFICATIONS”** section.
6. When bundle handler is suspended from a wire rope, ensure load is centered. Do not **“side pull”** or **“yard”**.
7. Never operate a bundle handler which is suspended from twisted, kinked or damaged wire rope.
8. Pay attention to the load at all times when operating the bundle handler.
9. Make sure everyone is clear of the load path. Do not lift a load over people.
10. Never use the bundle handler for lifting or lowering people, and never allow anyone to stand on a suspended load.
11. Never weld or cut a load suspended by the bundle handler.
12. Remove load and shut off air supply before performing any maintenance.
13. Do use good posture when operating the Bundle Handler.
14. Check interlock for proper operation at first operation of bundle handler.
15. Do check air connections for leakage.
16. Check clamp for smooth operation.

WARNING LABELS

Each bundle handler is shipped from the factory with the warning label shown. If the label is not attached to the bundle handler, order new label and install it. Label is shown actual size.

 **® ZIMMERMAN HANDLING SYSTEMS** **PN 10290**

 **WARNING!**

To Avoid Injury:

DO NOT: LEAVE BUNDLE HANDLER SUSPENDED WHEN NOT IN USE.

DO NOT: ATTEMPT TO MOVE A LOAD GREATER THAN THE BUNDLER HANDLER'S CAPACITY.

DO NOT: TURN BUNDLE HANDLER CONTINUOUSLY IN ONE DIRECTION.

DO NOT: ATTEMPT TO MOVE A LOOSELY CLAMPED LOAD.

DO NOT: PUT PERSONS OR BODY PARTS IN CLAMP PATH.

DO: USE GOOD POSTURE WHEN OPERATING BUNDLE HANDLER.

DO: CHECK INTERLOCK CIRCUIT AT FIRST OPERATION OF THE DAY.

DO: CHECK AIR CONNECTIONS FOR LEAKAGE.

DO: CHECK CLAMP FOR SMOOTH OPERATION.

SPECIFICATIONS

Features	Single Cylinder	Dual Cylinder	
Bundle Lengths	24-48 in. (610-1219 mm)	34-50 in. (864-1270 mm)	20-50 in. (508-1270 mm)
Maximum Load	250 lbs (114 kg)		
Minimum Bundle Length	24 in. (610 mm)	36 in. (915 mm)	22 in. (559 mm)
Maximum Bundle Length	48 in. (1219 mm)		
Clamp Force @ 90 psi (6.3 bar)	900 lbs (409 kg)	942 lbs (428 kg)	
Weight (varies with options)	100 lbs (45.5 kg)	180 lbs (82 kg)	
Maximum Operating Pressure	100 psi (6.9 bar)		

Description

The Bundle Handler is an ergonomic handling device designed to move ‘Signature Bundles*’. The Bundler Handler incorporates either a single or dual air cylinder system to open and close clamping plates (paddles).

Bundle Handlers are supplied with an interlock system to prevent accidental release of the bundle.

The Bundle Handler is designed to be supported by an Air Balancer and operated with an integral control system.

* A signature bundle or “Log” is a horizontal or vertical stack of paper usually from 24 in. (610 mm) to 48 in. (1219 mm) wide. The bundle is held together with a strap around the length, and has wood boards at each end. The stapled side of a signature is referred to as a spine.

Single Cylinder

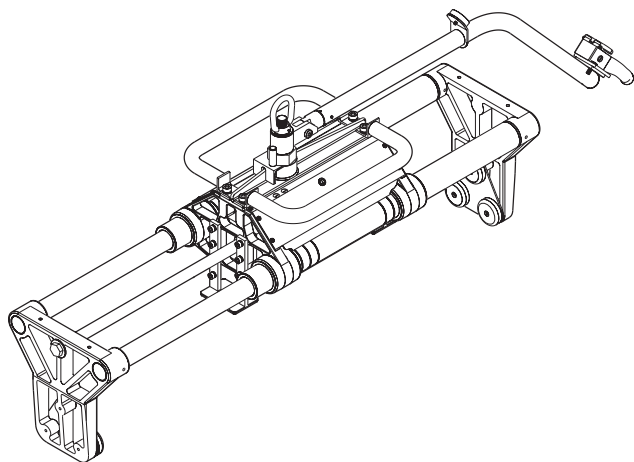

(Dwg. MHP2184)

- Standard paddles designed to clamp on end boards and handle cross sections from 6 in. x 9 in. (152 x 229 mm) to 12 in. x 12 in. (305 x 305 mm)
- Minimum bundle length of 24 in. (610 mm); maximum bundle length of 48 in. (1219 mm) (unit allows for 6 in. (152 mm) of variance between min/max bundle length)

Note: Although the bundle handler opens 10 in. (254 mm), it is recommended to allow 2 in. (51 mm) of variance to clear the bundle when fully opened and to allow for compression of the bundle when clamped.

Signature Bundle Handler - Single Cylinder - 8 in. Stroke

Unit No. Description

SBH12430	Lift bundles from 24 in. (610 mm) to 30 in. (762 mm)
SBH13036	Lift bundles from 30 in. (762 mm) to 36 in. (900 mm)
SBH13339	Lift bundles from 33 in. (838 mm) to 39 in. (991 mm)
SBH13642	Lift bundles from 36 in. (900 mm) to 42 in. (1067 mm)
SBH13743	Lift bundles from 37 in. (940 mm) to 43 in. (1092 mm)
SBH14046	Lift bundles from 40 in. (1016 mm) to 46 in. (1168 mm)
SBH14248	Lift bundles from 42 in. (1067 mm) to 48 in. (1219 mm)

Note: All units come equipped with hose, fittings and controls.

Model Code Explanation - Single Cylinder

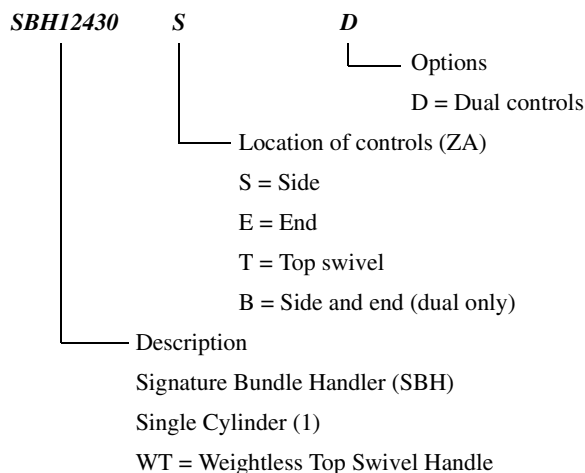

Dual Cylinder

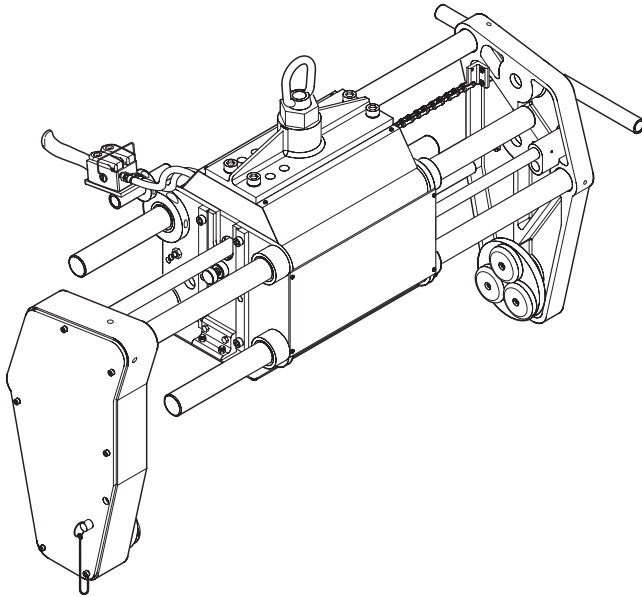

(Dwg. MHP2211)

- Designed to clamp on end boards and handle cross sections of up to 9.5 in. x 12.5 in. (241 x 318 mm)
- Extended paddles designed to clamp on end boards and handle cross sections up to 14.5 in. x 17.5 in. (368 x 445 mm)
- Maximum bundle length of 48 in. (1219 mm) (unit allows for 12 in. (305 mm) to 26 in. (660 mm) of variance between min/max bundle length based on cylinder length)

Note: Although the bundle handler opens 16 in. (406 mm) or 30 in. (762 mm), it is recommended to allow 2 in. (51 mm) of variance to clear the bundle when fully opened and to allow for compression of the bundle when clamped.

Model Code Explanation - Dual Cylinder

SBH22248	S	D	R	4
Options				
D = Dual controls				
R = Power rotate 90 or 180 degrees				
4 = 4 inch (102 mm) extended paddles				
Location of controls (ZA)				
S = Side				
E = End				
T = Top swivel				
B = Side and end (dual only)				
Description				
Signature Bundle Handler (SBH)				
Dual Cylinder (2)				
WT = Weightless Top Swivel Handle				
P = Power Paddle				
2P = Safety Interlock				

Signature Bundle Handler - Dual Cylinder - 16 in. Stroke

Unit No.	Description
SBH22248	Lift bundles from 22 in. (559 mm) to 38 in. (965 mm)
SBH22436	Lift bundles from 24 in. (610 mm) to 40 in. (1016 mm)
SBH22638	Lift bundles from 26 in. (660 mm) to 42 in. (1067 mm)
SBH23042	Lift bundles from 28 in. (711 mm) to 44 in. (1118 mm)
SBH23244	Lift bundles from 30 in. (762 mm) to 46 in. (1168 mm)
SBH23246	Lift bundles from 32 in. (813 mm) to 48 in. (1219 mm)
SBH23450	Lift bundles from 34 in. (864 mm) to 50 in. (1270 mm)

Note: All units come equipped with hose, fittings and controls.

Signature Bundle Handler - Dual Cylinder - 30 in. Stroke

Unit No.	Description
SBH22050	Lift bundles from 20 in. (508 mm) to 50 in. (1270 mm)

INSTALLATION

Prior to installing unit, carefully inspect it for possible shipping damage.

CAUTION

- Owners and users are advised to examine specific, local or other regulations, including American National Standards Institute and/or OSHA Regulations which may apply to a particular type of use of this product before installing or putting the unit into use.
- A falling load can cause injury or death. Before installing, read "SAFETY INFORMATION".

Ensure unit is properly installed. A little extra time and effort in doing so can contribute a lot toward preventing accidents, injuries and will help achieve the best service possible.

Always make certain the supporting member from which the unit is suspended is strong enough to support the weight of the unit plus the weight of a maximum rated load plus a generous factor of at least 300% of the combined weights. If in doubt, contact a registered structural engineer.

Positioning the Load Hook

To correctly install and position load hook to wire rope you must determine the following:

1. Highest point which load (bundle) must clear from floor (Dimension 1). Refer to Dwg. MHP2393 on page 6.
2. Distance from hook throat to bottom of load (bundle) (Dimension 2). Refer to Dwg. MHP2394 on page 6.

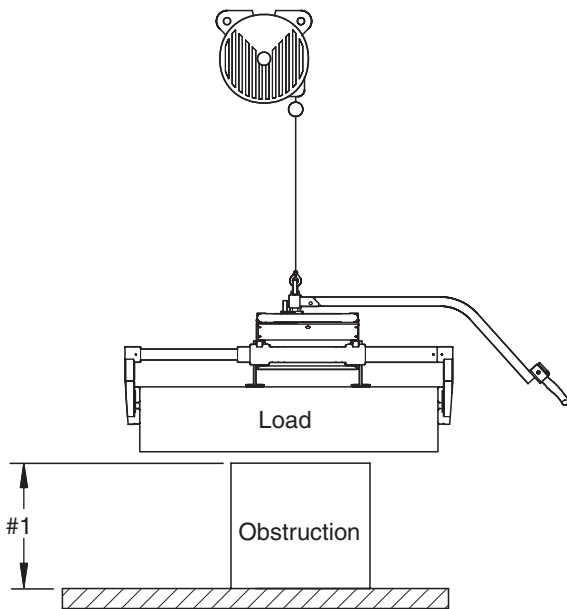

(Dwg. MHP2393)

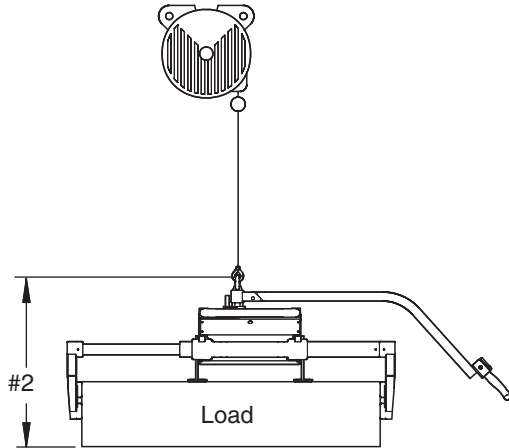

(Dwg. MHP2394)

3. Add dimension 1 to dimension 2, then add 3-1/2 inches (89 mm).
4. Measuring from the floor with the wire rope fully retracted, install hook using the dimension established in step 3. Refer to Balancer Parts, Operation and Maintenance Manual form MHD56151 for hook installation information.

Mounting The Unit

Insert load hook through lifting eye in Bundle Handler. Ensure Bundle Handler lifting eye is fully seated in load hook and that hook latch is resting on hook tip. Ensure Bundle Handler hangs freely in a horizontal position and does not tilt to one side or the other. Remove the ZA control manifold from the packaging. Ensure there is an 'O' ring on the back of the manifold at the balancer port. Install manifold using 4 mounting screws and lock washers. The white hose will be installed in the port to the left of the manifold.

Air System

The air supply system should be purged for a minimum of 30 seconds prior to the connection of the Balancer and Bundle Handler. This will remove any debris from the air lines and help prevent damage to the controls at start up. Zim-Air Balancers require 1/8 of a cubic ft. of air per cycle.

A minimum of 70 psi (4.8 bar) is recommended.

The Balancer reaches maximum capacity when 100 psi (6.9 bar) is applied, as air pressure decreases the unit capacity decreases proportionally. If 80 psi (5.5 bar) is applied to the balancer you will obtain 80% of rated capacity.

For a more detailed principle of operation refer to the Zimmerman Balancer Service Manual form number MHD56151.

⚠ WARNING

- Do not exceed 100 psig (6.9 bar/690 kPa) inlet pressure. Do not use a lubricator of any kind. Oil will damage internal components.
- The air supply must be clean and free from water and water vapor.

Air Lines

The inside diameter of unit air supply lines must not be smaller than 3/8 inch (10 mm) based on a maximum of 100 feet (30 m) of air line between air supply and unit. Contact factory for recommended air line sizes for distances greater than 100 feet (30 m). Before making final connections, all air supply lines should be purged. Supply lines should be as short and straight as installation conditions will permit. Long transmission lines and excessive use of fittings, elbows, tees, globe valves, etc. cause a reduction in pressure due to restrictions and surface friction in the lines. If quick-disconnect fittings are used at the inlet of the unit, they must have at least a 3/16 inch (10 mm) air passage. Use of smaller fittings will reduce performance.

Connection of Air Lines

ZA Control

Refer to Dwg. 2405 on page 7.

The control tube is pre-assembled tubing connected to the Bundle Handler. Control tubes are black, yellow and clear 3/8 inch (4.5 mm) and white 5/32 inch (3.9 mm) precoiled assemblies. The yellow tube must be connected to the down port of the ZA manifold on the balancer. The black tube must be attached to the up port of the ZA manifold. The white tube must be installed in the pilot port of the balancer.

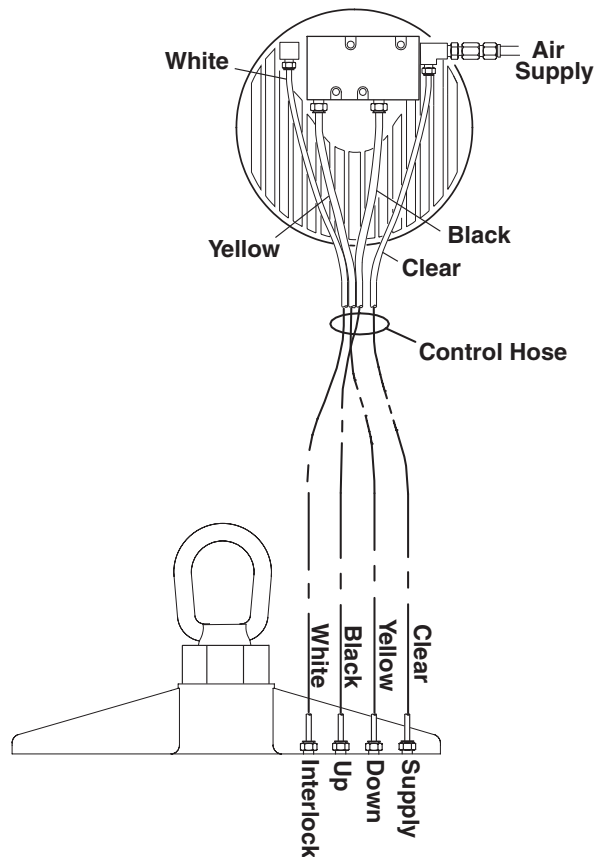

(Dwg. MHP2405)

Air Line Filter

It is recommended that an air line strainer/filter be installed as close as practical to the unit air inlet port. The strainer/filter should provide 5 micron filtration and include a moisture trap. Clean the strainer/filter monthly to maintain its operating efficiency.

To maintain dry air, the frequency for draining the filter should also be based on the condition of the air supply. We suggest the filter be drained weekly at first. Depending on air supply condition, a proper filter drain schedule should be established.

Moisture in Air Lines

Moisture that reaches the unit through supply lines is the chief factor in determining the length of time between service overhauls. Moisture traps can help to eliminate moisture. Other methods, such as an air receiver which collects moisture before it reaches the unit controls or an aftercooler at the compressor that cools the air prior to distribution through the supply lines, are also helpful.

Typical Bundler Handler Circuit

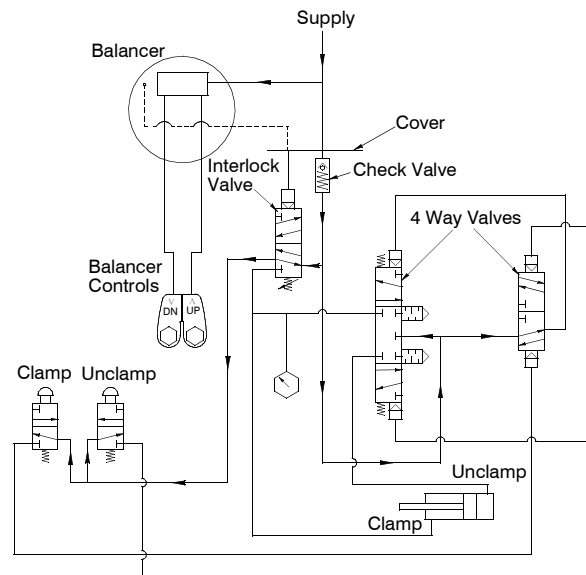

(Dwg. MHP2218)

OPERATION

Description Of Operation

Bundle Handler

The Bundle Handler is an integrated group of components designed to maximize the interaction of man and machine. These components can be mounted to an overhead rail system on which the **Zimmerman** Balancer travels. The Balancer has a wire rope with load hook attached to the Bundle Handler. The operator controls the system by use of the **Zimmerman** ZA (Zim-Air) up and down control to lift a bundle of signatures onto a stream feeder or directly to a gather in feed shelf. The clamp is actuated by push button or lever valves.

The system renders the bundles virtually weightless through the balancer's compressed air operation. The rail system or Manipulator Arm provides for ease of horizontal movement. This combination requires little physical strength to operate and reduces operator fatigue.

The Bundle Handler should not be left suspended when not in use. Lower device to the floor or a suitable location out of the work area. Always use good posture when operating the Bundler Handler.

The suspended bundle must have a clear passage from a pick up point to a set down point. The suspended bundle can be raised or lowered approximately twelve inches from which it has been raised by gently nudging the load up or down. This is known as floating. Use of the controls is not required for this operation, just pressure applied to the load by the operator in the desired direction.

Balancer

Energy used to power the balancer is compressed air, a minimum of 60 psig (3.1 bar/310 kPa) is required. Air is controlled by an external control package. Compressed air pushes against the piston, causing it to move laterally.

The piston pushes the reel assembly causing the reel to move laterally as well as rotate which winds the wire rope into the balancer, raising the Bundle Handler. Compressed air is released through the controls to atmosphere and the reel rotates in the opposite direction lowering the Bundle Handler.

The balancer reaches maximum capacity when 100 psig (6.9 bar/690 kPa) is applied. As air pressure decreases the unit capacity decreases proportionally. If 80 psig (5.5 bar/552 kPa) is applied to the balancer, maximum balancer operational capacity is 80% of rated capacity.

For additional information, refer to the Balancer Parts, Operation and Maintenance manual, form number MHD56151.

Control Types

The Bundle Handler uses the **Zimmerman** ZA (Zim-Air) control package. Controls are designed to provide flexible mounting options to suit operator preference and convenience. Refer to Dwg. MHP2396 on page 8 for a typical dual cylinder bundle handler.

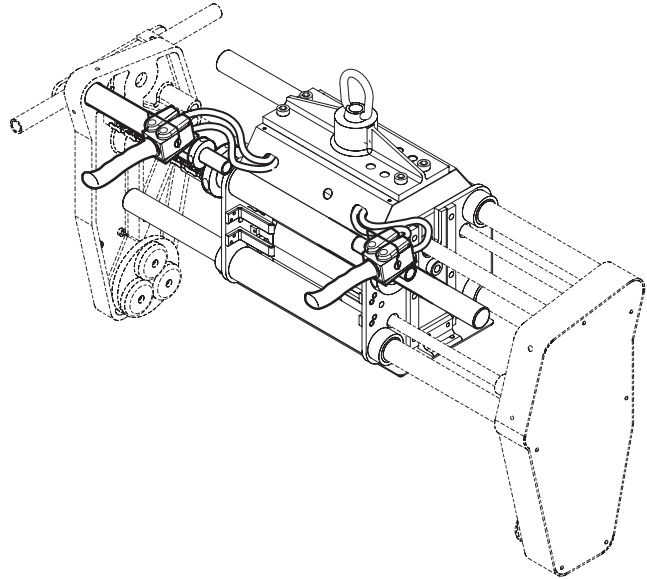

(Dwg. MHP2396)

ZA Control

Refer to Dwgs. MHP1819 on page 10 and MHP2405 on page 7. The Zim-Air control package utilizes an up/down control block, connected to the manifold mounted to the balancer. The top of the manifold has two flow control valves. The two flow control valves labeled "UP" and "DN" control the speed with which a load will raise and lower. The center screw control is for "hook balance adjustment" to maintain the Bundle Handler in a floating condition when it does not have a load on it.

Air is supplied through the manifold to the control block. When the "UP" lever is depressed, air passes through a passage in the block and into the balancer piston chamber resulting in the balancer raising the load. Lowering the load is accomplished by depressing the "DN" lever, which releases air in the balancer to atmosphere through the block, and lowers the load.

⚠ WARNING

- **Extreme care must be used until all control adjustments are complete.**

Clamp Interlock System

Zimmerman's interlock is a pilot operated valve. Pilot pressure from the balancer shifts the valve when a load greater than that of the empty SBH is lifted.

When the interlock valve is shifted the unclamp circuit is disabled, to prevent accidental unclamping of a suspended load, and air passes directly to the clamp side of the cylinder.

When the load is set down the pilot pressure from the balancer is reduced. The valve will shift to its original state allowing the unclamp circuit to function and the load to be released.

Bundle Handler Operation

⚠ WARNING

- If bundle is not held securely by Signature Bundle Handler and slips out of clamp, the empty handler will rise rapidly with the approximate force of the load.
- If system air pressure is lost, lower load immediately. The operator must stay out of the vertical path of the Bundle Handler and load. Clamp may lose force required to hold load which can cause severe injury or property damage.

The “UP” and “DN” levers allow adjustable speed control. As the lever is depressed further, the operational speed increases. Use the lever to ‘throttle’ the speed to ensure controlled movement of the Bundle Handler.

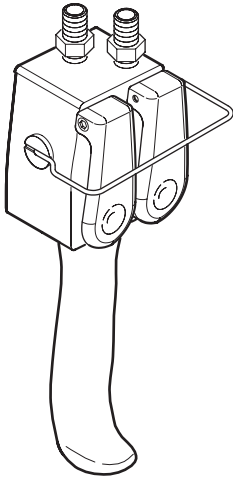

(Dwg. MHP2406)

⚠ CAUTION

- Do not wrap control hoses around wire rope. Damage to hoses and failure of Bundle Handler may result.

Proper turning of the Bundle Handler prevents twisting and wear of the balancer wire rope and air control lines. Do not attempt to continuously turn in one direction; rather reverse direction with each cycle.

Raising and lowering of the Bundle Handler is dependent on the type of control circuit on the handling device. The **Zim-Air (ZA)** type control requires manual lever operation to raise and lower the Bundle Handler.

1. Move Bundle Handler to the pick up point, and position it over the bundle for pick up. Actuate clamp open button or lever on control pendant.

⚠ CAUTION

- To prevent uncontrolled movement use both hands on the Bundle Handler when activating the clamp and rotate functions.
- Never attempt to lift a loosely clamped bundle. Rapid acceleration of the Signature Bundle Handler may cause the bundle to drop.
- Persons and body parts should never be in the path of the clamp paddles during operation. The clamp closes with extreme force and could result in injury.

2. Slowly lower Bundle Handler and engage the bundle. Center the clamp paddles on the end boards of the bundle. Actuate the clamp close button or lever and ensure bundle is securely clamped. If this is the first use of the SBH for the day, the (safety) interlock circuit should be tested. Depress the up lever to raise the bundle approximately 6 inches (152 mm) above the pick up point. Then actuate the cylinder clamp open button or lever. The clamp should not open and air should be heard exhausting from the clamp valve. If the clamp opens, notify maintenance personnel immediately.

⚠ CAUTION

- The suspended load may be raised or lowered approximately 12 inches (305 mm) by pushing or pulling the bundle in the desired direction.
 - The empty Signature Bundle Handler should not be left suspended when not in use. Lower the Signature Bundle Handler to the floor or pallet out of the work area.
3. Raise Bundle Handler to clear the pick up point and maneuver to the set down point.
 4. At the set down point depress the down lever and lower the bundle completely.
 5. Actuate the clamp open button or lever while continuing to depress the down lever to unclamp and disengage the bundle. Maneuver the Bundle Handler back to the pick up point and repeat steps.

Power Rotate Paddle (optional feature)

Refer to Dwgs. MHP2242 on page 24 and MHP2407 on page 9. The power rotate optional feature allows the bundle to be rotated a maximum of 180°.

Install the detent pin (110) in the paddle cover upper hole when not required or when using the full 180° rotate. Install the detent pin (110) in the paddle cover lower hole to stop rotation at 90°.

Ensure detent pin is pushed all the way in to engage detents.

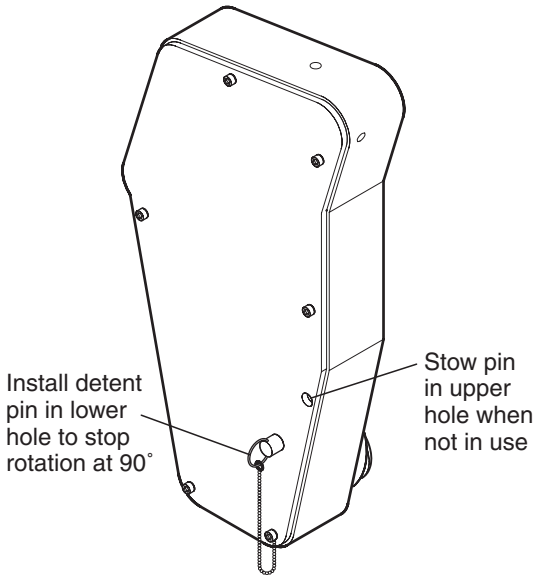

(Dwg. MHP2407)

Operation Adjustments

⚠ WARNING

- Air supply pressure must be a minimum of 60 psig (4.1 bar/410 kPa) and a maximum of 100 psig (6.9 bar/690 kPa). Excessive air pressure may damage the balancer or controls.
- Prior to adjustment of controls, ensure air is off and wire rope is slack.
- The interlock should not be adjusted until all control adjustments have been completed. The interlock may not function properly if it is set before the controls.

NOTICE

- When wire rope is winding into the balancer, air is passing through both up and down flow controls. If the up speed is too fast you may rotate the down control clockwise to decrease the up speed.

ZA Control

Refer to Dwg. MHP1819 on page 10.

1. On top of the ZA manifold are three screw type adjustable controls. Turn the “UP” and “DOWN” control screws clockwise until fully closed. Then turn each control screw counterclockwise one full turn.

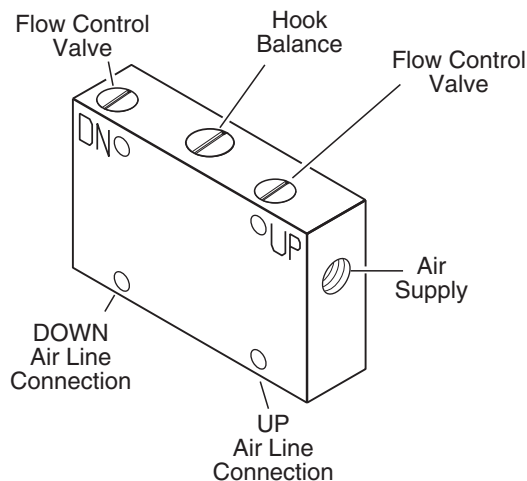

(Dwg. MHP1819)

2. The center control screw is for hook balance adjustment. The screw head should be flush with the top of the manifold body.

⚠ WARNING

- The screw type control and hook balance adjustment screws on the ZA manifold should never extend above the manifold body. Thread engagement will be minimal and could result in the screw being discharged from the manifold.

3. Turn on air supply. Adjust supply pressure to highest maintainable; do not exceed 100 psig (6.9 bar/690 kPa).
4. To set hook balance, adjust hook balance screw, by turning clockwise, until empty handling device begins to rise. Slowly adjust screw, by turning counterclockwise, until device stops moving.

5. Depress “DOWN” lever on the ZA control block. Adjust “DOWN” control screw, by turning counterclockwise, until desired down speed is reached.
6. Depress “UP” lever on the ZA control block. Adjust “UP” control screw, by turning counterclockwise, until desired speed is achieved.

Interlock Clamp Adjustment

⚠ CAUTION

- The interlock should not be adjusted until all control adjustments have been completed.

NOTICE

- It may be necessary to actuate clamp and unclamp button/lever several times to obtain the correct interlock setting.
- Interlock is only present on ZA controlled Bundle Handlers.

1. With empty Bundle Handler device suspended by the balancer, adjust interlock adjustment screw, by turning counterclockwise, until 3/4 inch (19 mm) of thread is visible.
2. While cycling clamp and unclamp functions, turn interlock adjustment screw clockwise until both clamp and unclamp circuits function.
3. Cycle clamp/unclamp switch several times to ensure smooth operation and that the interlock valve is shifting completely.
4. Raise empty Bundle Handler to its up stop. Depress ‘UP’ lever for 3 to 4 seconds to simulate a load on the balancer.
5. Actuate clamp and unclamp circuits. Clamp should not open. Air may be heard discharging to the atmosphere.
6. If clamp does open, repeat this adjustment procedure until clamp does not open with Bundle Handler at the up stop.
7. Once interlock valve is adjusted correctly, hold interlock stem with a suitable pair of pliers and tighten 3/8 inch jam nut on interlock adjustment screw to prevent setting from changing. Repeat the interlock test to ensure the setting did not change when the jam nut was tightened.

Platform Adjustment

If the platform is set too low the bundle may split out toward the platform. If the platform is set too high the bundle will split out toward the floor.

Manual Platform

Refer to Dwg. MHP2210 on page 20.

Platform (57) position is fixed (located) by a plunger (36) at each end. A limited amount of adjustment is available in either direction. The platform is factory set so that the gripper pads on the paddles align with the base of the bundle, to prevent the log from “splitting” out.

No adjustment should be necessary unless the log height changes.

If adjustment is required, pull both plungers (36) out while pushing up or down on the platform (57). Release the plungers and continue to move the platform until plungers fully engage the next hole position. Typically holes are spaced at 2 in. (51 mm) intervals.

Power Platform

Refer to Dwg. MHP2285 on page 28.

The power platform is adjusted by the threaded rod (84). The jam nuts (88) that thread onto the rods (84) act as stops for the air cylinders (83). The platform is factory set so that the gripper pads on the paddles align with the centerline of the bundle, to prevent the log from “splitting” out.

No adjustment should be necessary unless the log height changes.

Minor adjustment can be made by changing the position of the jam nuts (88) on threaded rods (84) to shorten the stroke of the air cylinders (83). The gripper pads on the paddles must align with the centerline of the bundle. When correct adjustment is achieved tighten jam nuts. Ensure platform is adjusted equally at both ends.

Yarding



- **Do not operate Bundle Handler if load is not centered under Balancer wire rope. Yarding of the wire rope will cause premature wear to wire rope and Balancer wire rope guides.**

Wire rope should not be yarded more than 10 degrees from vertical.

Excessive yarding may create unsafe operation, cause increased wear on balancer and decrease working life of related components.

⚠ WARNING

- All new or repaired equipment should be inspected and tested by personnel instructed in safety, operation and maintenance of this equipment to ensure safe operation at rated specifications before placing equipment in service.
- Never use a unit that inspection indicates is damaged.

Frequent and periodic inspections should be performed on equipment in regular service. Frequent inspections are visual examinations performed by operators or personnel trained in safety and operation of this equipment and include observations made during routine equipment operation. Periodic inspections are thorough inspections conducted by personnel trained in the safety, operation and maintenance of this equipment. Inspection intervals will depend upon the nature of the critical components of the equipment and the severity of usage.

Careful inspection on a regular basis will reveal potentially dangerous conditions while still in the early stages, allowing corrective action to be taken before the condition becomes dangerous.

Deficiencies revealed through inspection, or noted during operation, must be reported to designated personnel instructed in safety, operation and maintenance of this equipment. A determination as to whether a condition constitutes a safety hazard must be decided, and the correction of noted safety hazards accomplished and documented by written report before placing the equipment in service.

Records and Reports

Inspection records, listing all points requiring periodic inspection should be maintained for all load bearing equipment. Written reports, based on severity of service, should be made on the condition of critical parts as a method of documenting periodic inspections. These reports should be dated, signed by the person who performed the inspection, and kept on file where they are readily available for authorized review.

Frequent Inspections

For equipment in continuous service, frequent inspections should be made by operators at the beginning of each shift.

1. OPERATION. Check for visual signs or poor movement which could indicate a potential problem. Make sure all controls function properly. Check Bundle Handler swivels freely through 90 degrees.
2. INTERLOCK (Safety Circuit). ZA Controls only. Test operation with no load. Raise empty Bundle Handler to the "UP" stop. With "UP" lever depressed for 3 to 4 seconds (to simulate load), actuate clamp and unclamp circuit. Clamp should not open. Refer to "OPERATION" section, 'Interlock' for correction instructions.
3. AIR SYSTEM. Visually inspect all connections, fitting, hoses and components for indication of air leaks. Repair any leaks or damage, tighten any loose connections.

4. BALANCER. Follow inspection recommendations in Balancer Parts, Operation and Maintenance Manual form MHD56151.
5. GUIDE BARS. Ensure guide bars are clean and lubricated. Clean guide bars when dirty or binding occurs. Use a multipurpose synthetic Teflon lubricant to lubricate guide bars.
6. WIRE ROPE. Inspect for wear and lubrication. Replace kinked, frayed or twisted wire rope.

Periodic Inspection

Frequency of periodic inspection depends on the severity of usage:

NORMAL	HEAVY	SEVERE
Yearly	Semiannually	Quarterly

Disassembly may be required for HEAVY or SEVERE usage. Keep accumulative written records of periodic inspections to provide a basis for continuing evaluation.

Inspect all items in "Frequent Inspection". Also inspect the following:

1. FASTENERS. Check all rivets, split pins, capscrews and nuts. Replace if missing or tighten if loose.
2. ALL COMPONENTS. Inspect for wear, damage, deterioration, deformation and cleanliness. If external evidence indicates the need, disassemble. Check handles, housings, bearings, springs, clamp pads and covers. Replace worn or damaged parts. Clean, lubricate and reassemble.
3. SUPPORTING STRUCTURE. Check for distortion, wear and continued ability to support load.
4. LABELS AND TAGS. Check for presence and legibility of labels. Replace if damaged or missing.
5. BALANCER. Follow inspection recommendations in Balancer Parts, Operation and Maintenance Manual form MHD56151.
6. POWER ROTATE (optional feature). Inspect for proper operation and leakage.
7. COVERS. Check covers are installed and secure. Replace if damaged or missing.
8. ZA CONTROL HANDLE. Check for tubing leaks and security of connections. Ensure levers operate freely.

Units Not in Regular Use

1. Units which have been idle for a period of one month or more, but less than one year, should be given an inspection conforming with the requirements of "Frequent Inspection" prior to being placed into service.
2. Units which have been idle for a period of more than one year should be given an inspection conforming with the requirements of "Periodic Inspection" prior to being placed into service.
3. Standby units should be inspected at least semiannually in accordance with the requirements of "Frequent Inspection". In abnormal operating conditions, units should be inspected at shorter intervals.

INSPECTION AND MAINTENANCE REPORT

Ingersoll-Rand End Effectors

Bundle Handler

Model Number:	Date:
Serial Number:	Inspected By:
Reason for Inspection: (Check Applicable Box)	
1. Scheduled Periodic Inspection: _____ Quarterly _____ Semiannually _____ Yearly	Operating Environment: Normal _____ Heavy _____ Severe _____
2. Discrepancies noted during Frequent Inspection	
3. Discrepancies noted during Maintenance	
4. Other: _____	

Refer to the Parts, Operation and Maintenance Manual "INSPECTION" section for general inspection criteria. Also, refer to appropriate National Standards and codes of practice. If in doubt about an existing condition, contact the nearest **Ingersoll-Rand** Distributor or the factory for technical assistance.

COMPONENT	CONDITION		CORRECTIVE ACTION		NOTES
	Pass	Fail	Repair	Replace	
Fasteners/Fittings			---		
Hoses					
Lifting Eye Assembly			---		
Air Cylinder(s)					
Guide Bars					
Covers/Housings					
Controls/Switches			---		
Balancer					Refer to Balancer Parts, Operation and Maintenance Manual, MHD56151
Clamp Pads			---		
Handles					
Labels and Tags			---		
Other Components (list in NOTES section)					

This page may be photocopied and used as an Inspection/Maintenance record.

TROUBLESHOOTING

Refer to the Balancer Parts, Operation and Maintenance Manual for Balancer/Control specific problems. The following table is for Bundle Handler specific problems. This section provides basic troubleshooting information. Specific causes to problems are best identified by thorough inspections performed by personnel instructed in safety, operation and maintenance of this equipment. The chart below provides a brief guide to common symptoms, possible causes and remedies.

Symptom	Possible Cause	Remedy
Clamp does not close when clamp button or lever is actuated.	Air supply on Bundle Handler is off. Interlock valve is not set correctly.	Turn on air supply at Bundle Handler. Refer to Interlock (safety circuit) in the "OPERATION" section.
	Clamp switch incorrectly connected.	Refer to "PARTS" section for schematic drawings.
Clamp does not open when clamp button or lever is actuated.	The weight of the bundle has not been completely removed from the Bundle Handler.	Refer to Interlock (safety circuit) in the "OPERATION" section.
	Clamp switch incorrectly connected.	Refer to "PARTS" section for schematic drawings.
	The Interlock valve is not set correctly.	Refer to "OPERATION" section.
Clamp does not operate smoothly or does not function at all.	Debris in air lines or fittings.	Remove debris. Flush air lines.
	Loose or broken air lines or fittings.	Tighten connections or replace air lines or fittings.
	Improper interlock adjustment.	Refer to Adjustment Procedures.
	Faulty clamp button.	Replace clamp button.
	Faulty clamp valve.	Replace clamp valve.
	Faulty air cylinder.	Replace air cylinder.
	Lack of guide bar lubrication.	Clean and lubricate guide bars.
	Guide bar bushings worn.	Replace guide bar bushings.
	Improper chain tension.	Adjust chain tension.
Broken chain.	Replace chain.	
Power rotate of bundle does not operate smoothly or is inoperative.	Debris in air lines or fittings.	Remove debris. Flush air lines.
	Loose or broken air lines or fittings.	Tighten connections or replace air lines or fittings.
	Faulty rotate lever valve.	Replace lever valve.
	Faulty air cylinder.	Replace air cylinder.
	Improper chain tension.	Adjust chain tension.
	Broken chain.	Replace chain.
Interlock does not prevent clamp from opening with a load.	Debris in air lines or fittings.	Remove debris. Flush air lines.
	Loose or broken air lines or fittings.	Tighten connections or replace air lines or fittings.
	Improper interlock adjustment.	Refer to Adjustment Procedures.
	Faulty Interlock valve.	Replace Interlock valve.
Load shifts or slips with clamp engaged.	Deteriorated, loose or damaged clamp pads.	Tighten or replace clamp pads.
	Insufficient air supply pressure.	Adjust air supply to the highest maintainable pressure.
	Bundle strap loose.	Check strapper equipment.

MAINTENANCE

⚠ CAUTION

- Use of replacement parts other than Ingersoll-Rand original parts could result in damage to the unit and void the warranty.

⚠ WARNING

- Turn off air supply to system and be sure wire rope is slack before attempting any disassembly operations.
- Never perform maintenance on the unit while it is supporting a load.
- Before performing maintenance, tag controls:

**WARNING - DO NOT OPERATE -
EQUIPMENT BEING REPAIRED**

- Only allow personnel trained in safety and maintenance on this unit to perform service.

Maintenance Intervals

The Maintenance Interval chart is based on intermittent operation of the Bundle Handler eight hours each day, five days per week. If Bundle Handler operation is more than eight hours per day, or in HEAVY or SEVERE environments, more frequent maintenance should be performed. Refer to “Periodic Inspection” in the “INSPECTION” section for additional information.

INTERVAL	MAINTENANCE CHECK
Start of each shift (Operator or Maintenance Personnel)	Make a thorough visual inspection of the Bundle Handler for damage. Do not operate if damaged. Operate the system through the normal range of movements. System must operate smoothly without sticking, binding or abnormal noises.
3 Months (Maintenance Personnel)	Inspect interlock. Clean or replace parts as required. Check pivot assembly and guide bars.
Yearly (Maintenance Personnel)	Check all the supporting members, including the balancer, fasteners, nuts, etc. for indications of damage or wear. Repair or replace as required.

Adjustments

Refer to “OPERATION” section for all adjustments.

Disassembly

Refer to Dwgs. MHP2181 on page 18 and MHP2210 on page 20. Labeling all air lines with valve port number or location prior to disconnection will ease reassembly of the Bundle Handler.

1. Lower Bundle Handler to the floor or a suitable work surface.
2. Turn off and lock out the system air supply.

3. Depress the down lever until all the air has been exhausted from the balancer and the load cable is slack.
4. Remove the load hook from the Bundle Handler lifting eye.
5. Label and disconnect the air lines at the top of the Bundle Handler.
6. Remove 4 socket head capscrews and lockwashers from top of Bundle Handler.
7. Remove Bundle Handler top cover.
8. Remove socket head capscrews from the top front and back side covers.
9. Remove top front and back side covers.
10. Ensure all cable ties are removed prior to any component removal and replaced upon completion of tasks.

Interlock Valve Removal/Replacement

Refer to Dwg. MHP2183 on page 30.

1. Complete the General Disassembly Procedures 1-10.
2. Label and disconnect air lines to the valve package.
3. Carefully remove the valve package from Bundle Handler.
4. Label and disconnect air fittings connected to the interlock valve (59).
5. Remove interlock valve (59).
6. Assemble in reverse order.
7. Adjust and test interlock valve. Refer to “OPERATION” section.

⚠ WARNING

- The interlock valve must be adjusted and tested prior to putting the Bundle Handler into production.

Clamp and Power Rotate Button Valve Removal/Replacement

1. Complete the General Disassembly Procedures 1-10.
2. Label air lines and disconnect from push button valve.
3. Remove the setscrew from push button.
4. Label and disconnect fittings from push button.
5. Remove push button valve.
6. Assemble in reverse order.

Cylinder Clamp/Unclamp Valve Removal/Replacement

1. Complete the General Disassembly Procedures 1-10.
2. Label air lines and disconnect from cylinder clamp/unclamp valves.
3. Carefully remove the valve package.
4. Label and disconnect air fittings from cylinder clamp/unclamp valves.
5. Remove cylinder clamp valve.
6. Assemble in reverse order.

NOTICE

- If removing lower air cylinder the Bundle Handler may be rotated to one side for ease of maintenance.

Air Cylinder Clamp Removal/Replacement

Refer to Dwgs. MHP2210 on page 20 and MHP2181 on page 18.

1. Complete the General Disassembly Procedures 1-10.
2. Label all air lines to be disconnected.
3. Carefully remove valve package.
4. Hold air cylinder rod end with proper size wrench.
5. Remove rod end bolt and washer from outside of paddle.
6. Remove 4 socket head capscrews and lockwashers from air cylinder rod end and piston end.
7. Remove air cylinder(s).
8. Assemble in reverse order.

Guide Bar Assembly Removal/Replacement

1. Complete General Disassembly Procedures 1-10.
2. Remove bottom support plate.
3. Remove air cylinder clamp mount socket head screws from end cover.
4. Remove end cover.
5. Remove roll pin from paddle end of guide bar being replaced.
6. Slide guide bar assembly out of opposite end cover.
7. Assemble in reverse order.
8. Lightly lubricate guide bar assembly.

Clamp Chain Removal/Replacement

Refer to Dwg. MHP2210 on page 20.

NOTICE

• **When replacing chain ensure the new chain has the same number of links as the chain not being replaced. This will make adjustment of the new chain less difficult.**

1. Complete the General Disassembly Procedures 1-10.
2. Remove 4 socket head capscrews (60) from side cover of chain being replaced.
3. Loosen tension nut (40) of chain being replaced.
4. Slide sprocket assembly to loosen chain.
5. Identify and remove the chain master links (27). One master link is located at the sprocket assembly. The second master link is located on the paddle at the chain attaching bracket (23).
6. Remove chain (26).
7. Assemble in reverse order.
8. Perform chain tension adjustments.

Chain Tension Adjustments

Refer to Dwg. MHP2210 on page 20.

1. Open Bundle Handler clamp paddles.
2. Tighten tension nut (40) until chain has no noticeable slack.
3. Check tension rod (68) for bending.
4. If tension rod is bending — loosen tension nut until tension rod becomes straight.
5. Cycle clamp/unclamp circuit. Ensure chain does not jump sprocket. Check for chain chatter and slack when in clamp cycle.

6. If chain jumps sprocket — loosen tension nut and install chain on sprocket. Repeat steps 1-5.
7. If chain chatters or slack is detected — Repeat steps 1-5.
8. The chain will be properly adjusted when clamp paddles move simultaneously with no slack on either chain or bending of tension rod.

Power Rotate Air Cylinder Removal/Replacement

Refer to Dwg. MHP2242 on page 24.

1. Complete General Disassembly Procedures steps 1-10.
2. Remove paddle end cover (111).
3. Label and disconnect air lines from air cylinders (97) to be removed.
4. Loosen locknuts (96). Slide sprocket assembly to loosen chain.
5. Remove socket head capscrews (106) attaching chain to tension block (105) on cylinder rod end.
6. Remove cotter pin (99) from cylinder mount dowel pin (100).
7. Remove cylinder mount clevis dowel pin (100).
8. Remove air cylinder (97).
9. Remove chain tension block from air cylinder rod end.
10. Assemble in reverse order.
11. Perform Power Rotate Chain Tension Adjustments.

Power Rotate Chain Removal/Replacement

1. Complete General Disassembly Procedures steps 1-10.
2. Remove paddle end cover (111).
3. Loosen tension locknut (96) until chain is slack.
4. Identify and remove master links (108) of chain.
5. Remove chain (89).
6. Assemble in reverse order.
7. Perform chain tension adjustments.

Power Rotate Chain Tension Adjustment

1. Tighten tension locknut (96) until chain has no slack.
2. Cycle power rotate.
3. Check for chain clatter and slack during cycle.
4. Repeat steps 1-3 until rotating paddle moves smoothly.

Cleaning, Inspection and Repair

Examine disassembled components and fasteners for wear or damage. If worn or damaged, do not reuse. During reassembly all damaged and worn components should be replaced to prevent component failure which may result in injury or property damage.

It is recommended that locknuts be discarded and replaced with new ones after each use.

Use the following procedures to clean, inspect and repair the Bundle Handler and associated components.

Cleaning

Thoroughly clean all Bundle Handler components in solvent. The use of a stiff bristle brush will facilitate the removal of accumulated dirt and sediments on the housings. Wipe off each part after cleaning. Remove all old Loctite® residue.

Inspection

All disassembled parts should be inspected to determine their fitness for continued use. Pay particular attention to the following:

1. Inspect all threaded items and replace those having damaged threads.
2. Inspect pivot handle. Replace if bent, distorted or worn.
3. Inspect air lines for cracks, cuts and leakage. Ensure there are no pinched air hoses.
4. Inspect air fittings for cracks, leakage and security.
5. Inspect maneuvering handles for wear and damage.
6. Ensure clamp valve functions.
7. Ensure Bundle Handler support swivel assembly rotates freely.

Repair

Actual repairs are limited to the removal of small burrs and other minor surface imperfections. Use a fine stone or emery cloth for this work.

1. Worn or damaged parts must be replaced. Refer to parts section for specific replacement parts information.
2. Inspect all remaining parts for evidence of wear or damage. Replace or repair any parts which are in questionable condition. The cost of the part is often minor in comparison with the cost of redoing the job.

Assembly

Bundle Handler

Refer to Dwgs. MHP2181 on page 18 and MHP2210 on page 20.

1. Gather air lines together and install cable ties to ensure lines do not rub, bind or get pinched during Bundle Handler operation.
2. Install top front and back side covers with capscrews.
3. Install Bundle Handler top cover with lockwashers and capscrews.
4. Connect air lines to the top of the Bundle Handler as labeled during disassembly.
5. Attach the Balancer load hook to the Bundle Handler lifting eye.
6. Turn on the system air supply.
7. Check all Bundle Handler functions to ensure correct operation.

Testing

Prior to testing Bundle Handlers, various control valves must be adjusted. Refer to 'Operation Adjustments' on page 10 for these adjustments.

Bundle Handler

With NO load:

1. Actuate 'UP' lever. Bundle Handler should rise smoothly. Actuate 'DOWN' lever. Bundle Handler should lower smoothly. If movement direction does not match levers, correct before placing Bundle Handler in service.
2. Actuate clamp control.
3. Actuate rotate control if equipped.

With Load:

1. Place a test load equal to 100% of capacity.
2. Actuate 'UP' lever. Bundle Handler should rise smoothly. Actuate 'DOWN' lever. Bundle Handler should lower smoothly. If movement direction does not match levers, correct before placing Bundle Handler in service.
3. Actuate clamp control.

Interlock Valve

NOTICE

• **Interlock valve will not allow clamp control to release while Bundle Handler is supporting a load.**

1. To test, engage nose assembly in a load and lift 2-3 inches (51-76 mm) off the floor. Actuate clamp control to the unclamp position. Load should remain secured to Bundle Handler. For adjustments refer to 'Operation Adjustments' on page 10.

BUNDLE HANDLER ASSEMBLY PARTS DRAWING

Single Cylinder for 24 to 48 inch (610 to 1219 mm) bundles

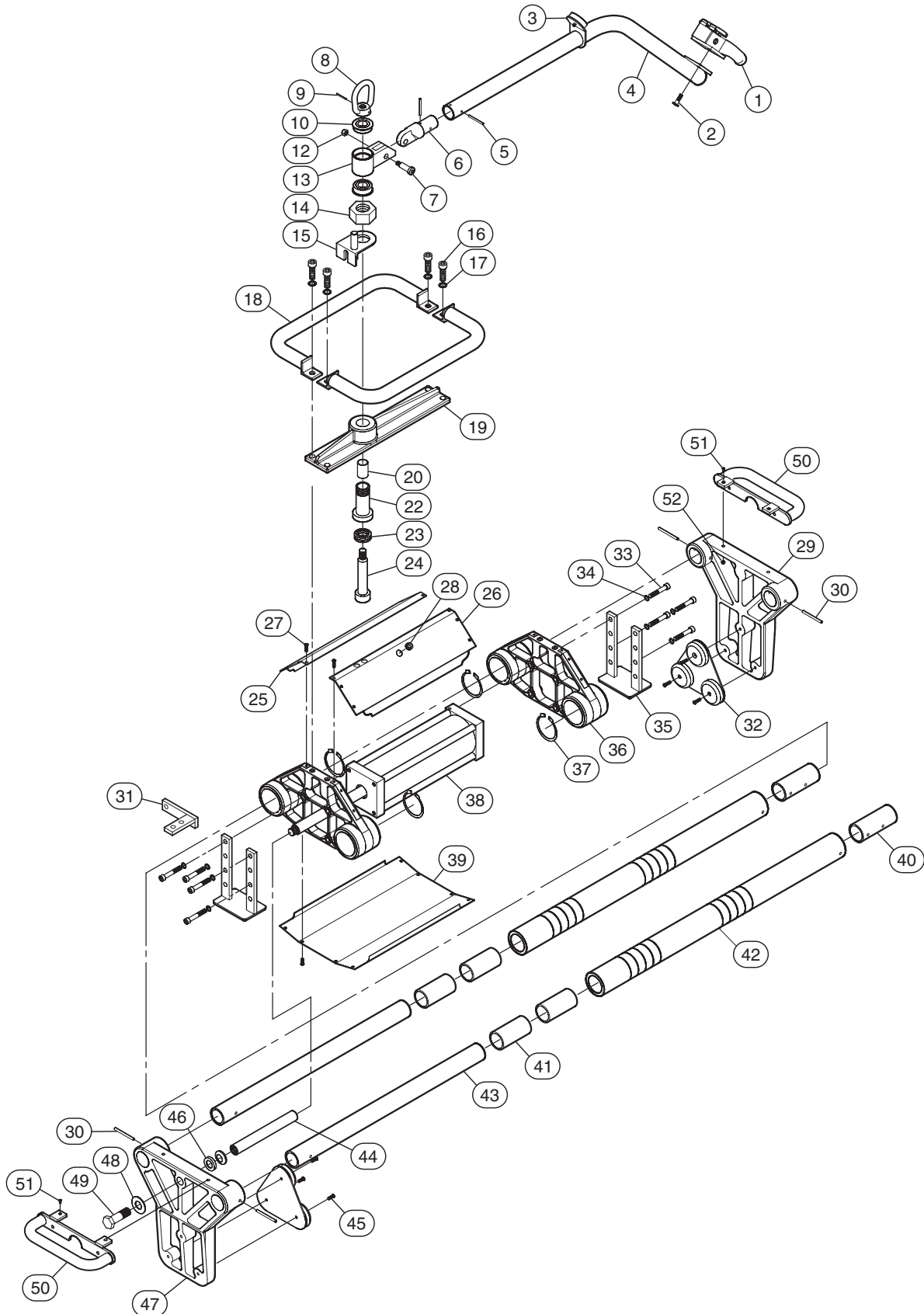

(Dwg. MHP2181)

BUNDLE HANDLER ASSEMBLY PARTS LIST

Item No.	Description of Part	Qty Total	Part Number	Item No.	Description of Part	Qty Total	Part Number
1	Control Handle Assembly	1	18600	28	Grommet	1	99146
2	Screw	3	70424	29	Fixed Paddle	1	96947
3	Pressure Gauge	1	99152	30	Pin	6	77048
4	Handle	1	97370-15	31	Bracket	1	97501
5	Pin	2	77058	32	Clamp Pad	2	96952
6	Pivot	1	96959	33	Capscrew	8	71508
7	Shoulder Screw	1	72006	34	Lockwasher	8	74530
8	Eye Nut	1	99147	35	Rest Pad	2	96954
9	Pin	1	01814	36	Cylinder Mount	1	96949
10	Bearing	2	65117	37	Retainer Ring	4	99145
12	Locknut	1	75511	38	Cylinder	1	60604
13	Handle Mount	1	96958	39	Bottom Cover	1	96951
14	Nut	1	75534	40	Sleeve	2	65117
15	Handle Stop	1	96957	41	Bearing	4	65042
16	Capscrew	4	72024	42	Support Tube	2	96941
17	Lockwasher	4	74532	43	Guide Bar	2	97081
18	Handle Bar	2	97370-75	44	Extension	1	97377
19	Lift Bale	1	96943	45	Screw	6	70455
20	Bushing	1	65119	46	Spherical Washer Set	1	99011
22	Sleeve	1	96944	47	Clamp Paddle	1	96946
23	Bearing	1	65118	48	Washer	1	74516
24	Shoulder Screw	1	73133	49	Capscrew	1	10013
25	Cover	1	96950	50	'D' Handle (optional)	2	97370-75
26	Cover (air supply side)	1	97074	51	Capscrew	4	*
27	Capscrew	20	70112	52	Nut	4	75528

* Contact factory

BUNDLE HANDLER ASSEMBLY PARTS DRAWING

Dual Cylinder
34 to 50 inch (864 to 1270 mm) with Standard Length Paddles

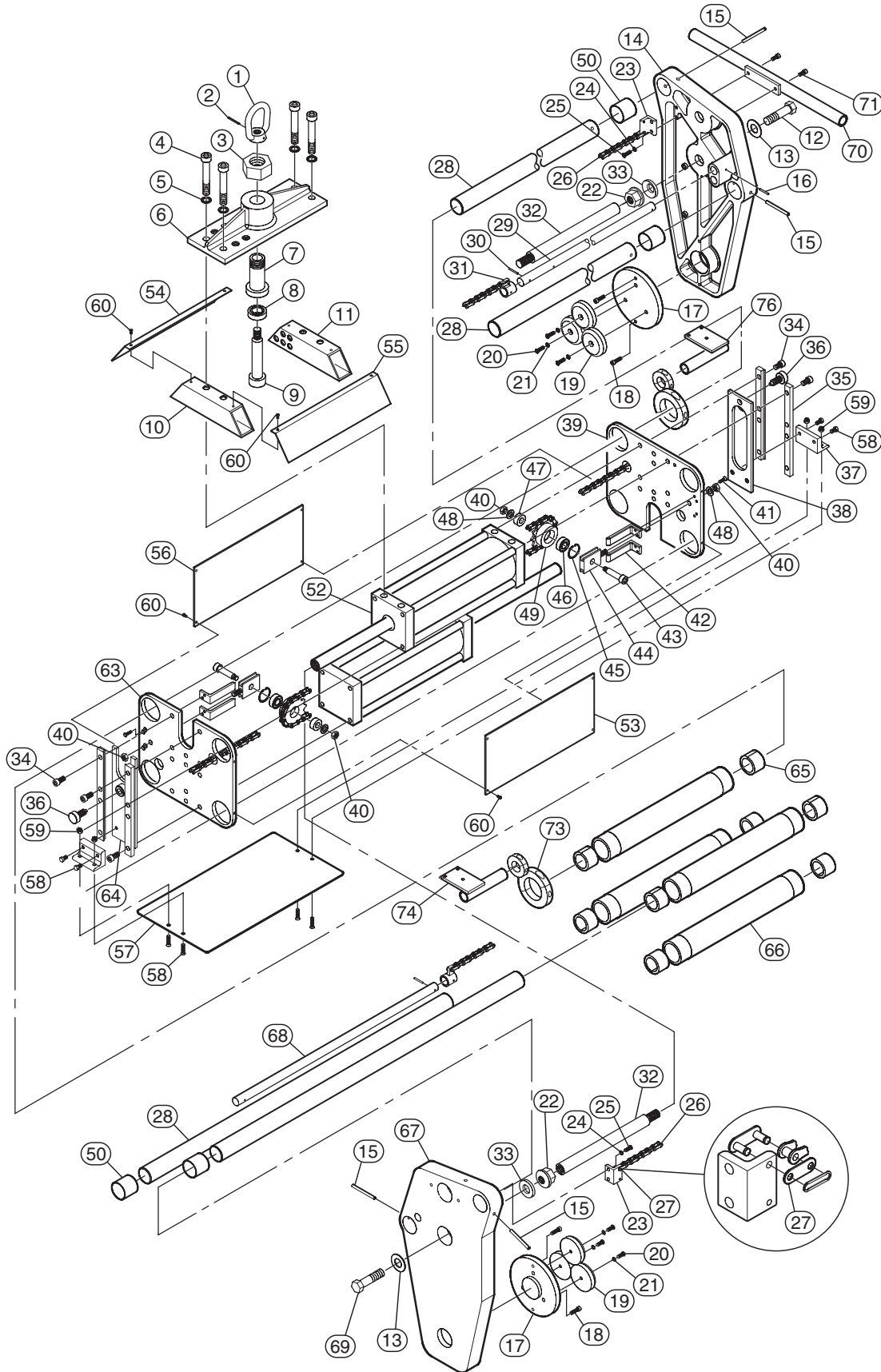

(Dwg. MHP2210)

BUNDLE HANDLER ASSEMBLY PARTS LIST

34 to 50 inch (864 to 1270 mm) with Standard Length Paddles

Item No.	Description of Part	Qty Total	Part Number	Item No.	Description of Part	Qty Total	Part Number
1	Eye Nut	1	99147	38	Side Guide LH	1	95483018
2	Pin	1	01814	39	End Plate LH	1	95483016
3	Nut	1	75516	40	Locknut	4	75511
4	Capscrew	4	72047	41	Screw	8	70219
5	Lockwasher	4	74513	42	Tension Block Bracket	4	95483031
6	Lift Bale	1	95483037	43	Shoulder Screw	2	72005
7	Sleeve	1	96944	44	Tension Block	2	95483012
8	Bearing	1	65118	45	Retainer Ring	2	65050
9	Shoulder Screw	1	73132	46	Bearing	2	65012
10	Riser RH	1	95483027	47	Spacer	2	95483019
11	Riser LH	1	95483028	48	Washer	2	74508
12	Capscrew	1	73143	49	Sprocket	2	95483020
13	Washer	2	74516	52	Cylinder (4 x 8 in.)	2	60600
14	Paddle LH	1	95508	53	Cover Far Side	1	95483025
15	Pin	4	77048	54	Cover Near Side	1	95483029
16	Pin	2	77054	55	Cover Far Side	1	95483030
17	Rigid Bumper Mount	2	95536094	56	Cover Near Side	1	95483010
18	Capscrew	4	15782	57	Platform	1	95483036
19	Bumper	6	93096	58	Screw	8	70446
20	Capscrew	6	70919	59	Locknut	8	75503
21	Washer	6	74529	60	Screw	12	70112
22	Locknut	2	75517	63	End Plate RH	1	95483015
23	Chain Bracket	2	95483013	64	Side Guide RH	1	95483018
24	Lockwasher	4	16099	65	Bearing	8	65042
25	Capscrew	4	70437	66	Bearing Tube	4	95483009
26	Roller Chain	As Req'd	99005	67	Paddle RH	1	95508
27	Chain Connecting Link	4	99006	68	Arm RH	1	95483014
28	Guide Bar (1.67 in. dia)	4	96138	69	Capscrew	1	10019
29	Arm LH	1	95483011	70	End Handle	1	95483022
30	Pin	2	77005	71	Capscrew	2	70430
31	Arm Bracket	2	95483032	73	Handle Clamp	2	95483024
32	Cylinder Rod Extension	2	95483041	74	Control Handle Mount RH	1	95483023
33	Spherical Washer	2	99011	75	Capscrew	4	*
34	Capscrew	16	71473	76	Control Handle Mount LH	1	95483038
35	Side Guide	4	95483017	77	Control Handle Mount, End Paddle	2	95483034
36	Plunger	2	99012				
37	Platform Bracket	2	95483035				

* Contact factory

20 to 50 inch (508 to 1270 mm) with Standard Length Paddles

Item No.	Description of Part	Qty Total	Part Number	Item No.	Description of Part	Qty Total	Part Number
6	Lift Bale	1	95537002	55	Cover Far Side	1	95537009
28	Guide Bar (1.5 in. dia)	4	96128	56	Cover Near Side	1	95537003
29	Arm LH	1	95537011	57	Platform	1	95537001
32	Rod Extension	2	Not required	65	Bearing	8	65048
50	Bearing	4	65047	66	Bearing Tube	3	95537005-35
52	Cylinder (4 x 15 in.)	2	60605	66	Bearing Tube	1	95537005-40
53	Cover Far Side	1	95537004	68	Arm RH	1	95537011
54	Cover Near Side	1	95537008				

BUNDLE HANDLER ASSEMBLY PARTS DRAWING

Dual Cylinder
34 to 50 in. (864 to 1270 mm) with 4 inch Extended Length Paddles

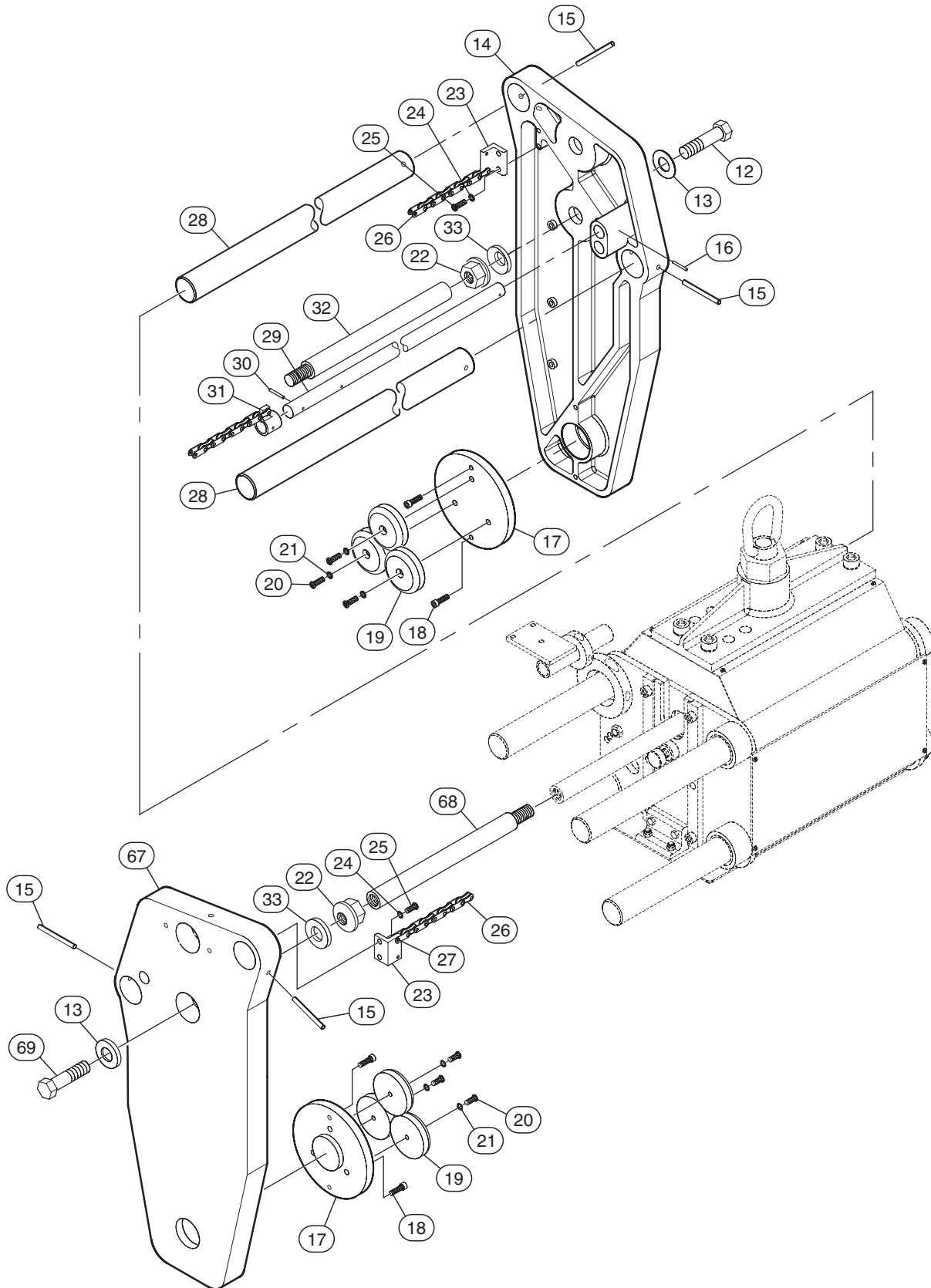

(Dwg. MHP2401)

BUNDLE HANDLER ASSEMBLY PARTS LIST

Item No.	Description of Part	Qty Total	Part Number	Item No.	Description of Part	Qty Total	Part Number
1	Eye Nut	1	99147	38	Side Guide LH	1	95483039
2	Pin	1	01814	39	End Plate LH	1	95483016
3	Nut	1	75516	40	Locknut	4	75511
4	Capscrew	4	72047	41	Screw	8	70219
5	Lockwasher	4	74513	42	Tension Block Bracket	4	95483031
6	Lift Bale	1	95483037	43	Shoulder Screw	2	72005
7	Sleeve	1	96944	44	Tension Block	2	95483012
8	Bearing	1	65118	45	Retainer Ring	2	65050
9	Shoulder Screw	1	73132	46	Bearing	2	65012
10	Riser RH	1	95483027	47	Spacer	2	95483019
11	Riser LH	1	95483028	48	Washer	2	74508
12	Capscrew	1	73143	49	Sprocket	2	95483020
13	Washer	4	74516	52	Cylinder (4 x 15 in.)	2	60605
14	Paddle LH	1	97523	53	Cover Far Side	1	95483025
15	Pin	4	77048	54	Cover Near Side	1	95483029
16	Pin	2	77054	55	Cover Far Side	1	95483030
17	Rigid Bumper Mount	2	95536094	56	Cover Near Side	1	95483010
18	Capscrew	4	15782	57	Platform	1	95483036
19	Bumper	6	93096	58	Screw	8	70446
20	Capscrew	6	70919	59	Locknut	8	75503
21	Washer	6	74529	60	Screw	12	70112
22	Locknut	2	75517	63	End Plate RH	1	95483015
23	Chain Bracket	2	95483013	64	Side Guide RH	1	95483040
24	Lockwasher	4	74506	65	Bearing	8	65042
25	Capscrew	4	70437	66	Bearing Tube	4	95483009
26	Roller Chain	As Req'd	99005	67	Paddle RH	1	95508
27	Chain Connecting Link	4	99006	68	Arm RH	1	95483014
28	Guide Bar	4	96138	69	Capscrew	1	10019
29	Arm LH	1	95483011	70	End Handle	1	95483022
30	Pin	2	77005	71	Capscrew	2	70430
31	Arm Bracket	2	95483032	73	Handle Clamp	2	95483024
32	Cylinder Rod Extension	2	95483041	74	Control Handle Mount RH	1	95483023
33	Spherical Washer Set	2	99011	75	Capscrew	4	*
34	Capscrew	16	71473	76	Control Handle Mount LH	1	95483038
35	Side Guide	4	95483017	77	Control Handle Mount, End Paddle	2	95483034
36	Plunger	2	99012				
37	Platform Bracket	2	95483035				

* Contact factory

Refer to Dwg. MHP2210 on page 20 for parts listed on this page that are not shown on Dwg. MHP2401.

POWER ROTATE PADDLE ASSEMBLY PARTS DRAWING

Standard Length Paddles

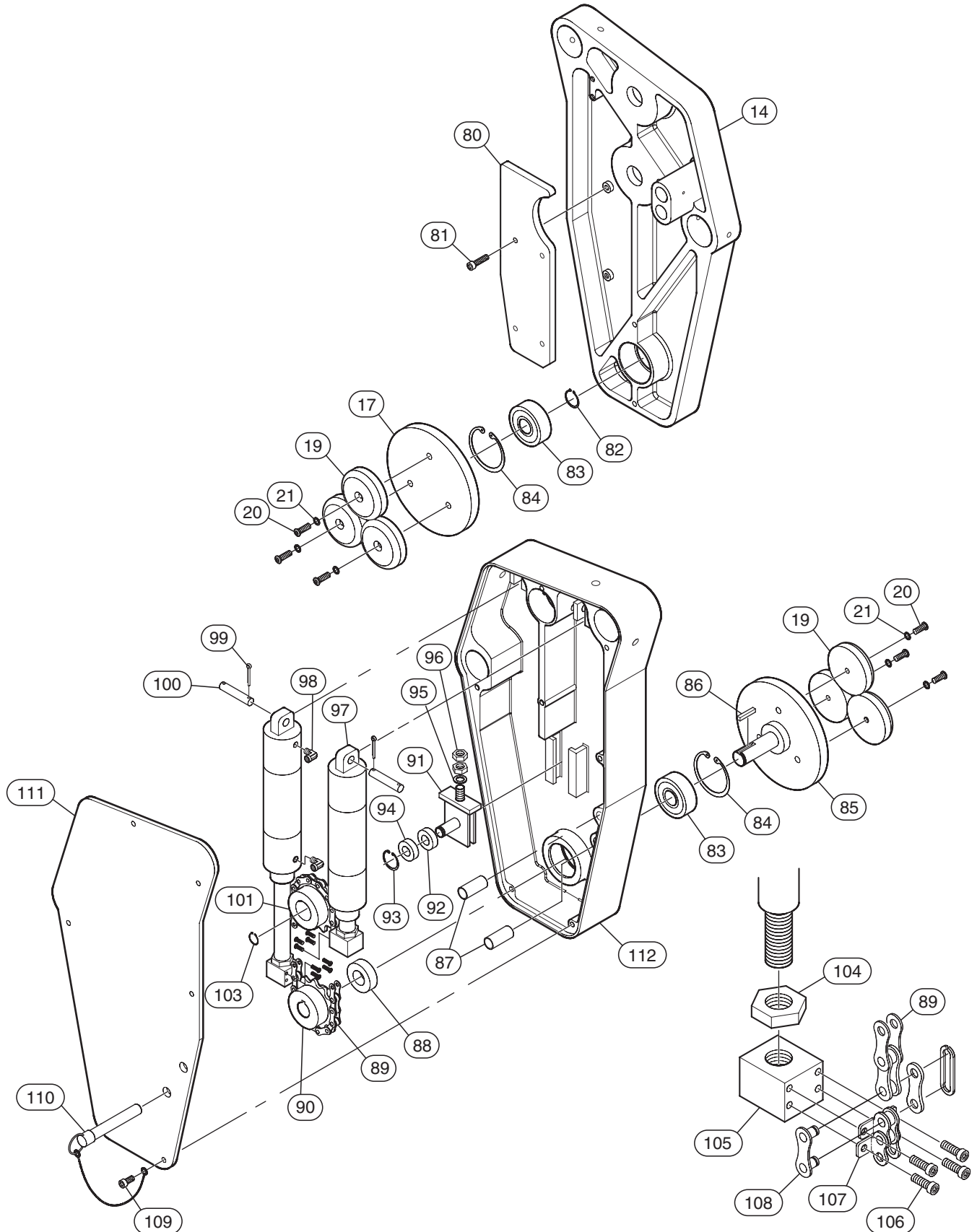

(Dwg. MHP2242)

POWER ROTATE PADDLE ASSEMBLY PARTS LIST

Item No.	Description of Part	Qty Total	Part Number	Item No.	Description of Part	Qty Total	Part Number
14	Paddle LH	1	95508	94	Bearing	1	65012
17	Bumper Mount	1	95483026	95	Washer	1	74508
19	Bumper	6	93096	96	Locknut	2	75542
20	Capscrew	6	70919	97	Cylinder (2 x 3.75 in.)	2	60750
21	Washer	6	74529	98	Fitting, Elbow	4	93970
80	Counterweight	1	95872	99	Cotter Pin	2	*
81	Capscrew	4	15782	100	Pin	2	95483006
82	Retainer Ring	1	65053	101	Sprocket	1	95483008
83	Bearing	2	65043	103	Retainer Ring	1	65052
84	Retainer Ring	2	65051	104	Locknut	2	75558
85	Bumper Mount, Power Rotate	1	95483003	105	Chain Tension Block	2	95483005
86	Key	1	3/16 sq x 1	106	Capscrew	8	70011
87	Bushing	2	65046	107	Chain Link Attachment	2	99003
88	Spacer	1	95483004	108	Master Link	3	99006
89	Chain	1	99005	109	Capscrew	7	70423
90	Sprocket	1	99002	110	Detent Pin	1	99010
91	Tension Plate	1	95483007	111	Cover	1	95509
92	Spacer	1	95483002	112	Paddle, Power Rotate RH	1	95506
93	Retainer Ring	1	65050				

* Contact factory

POWER ROTATE PADDLE ASSEMBLY PARTS DRAWING

4 inch (102 mm) Extended Paddles

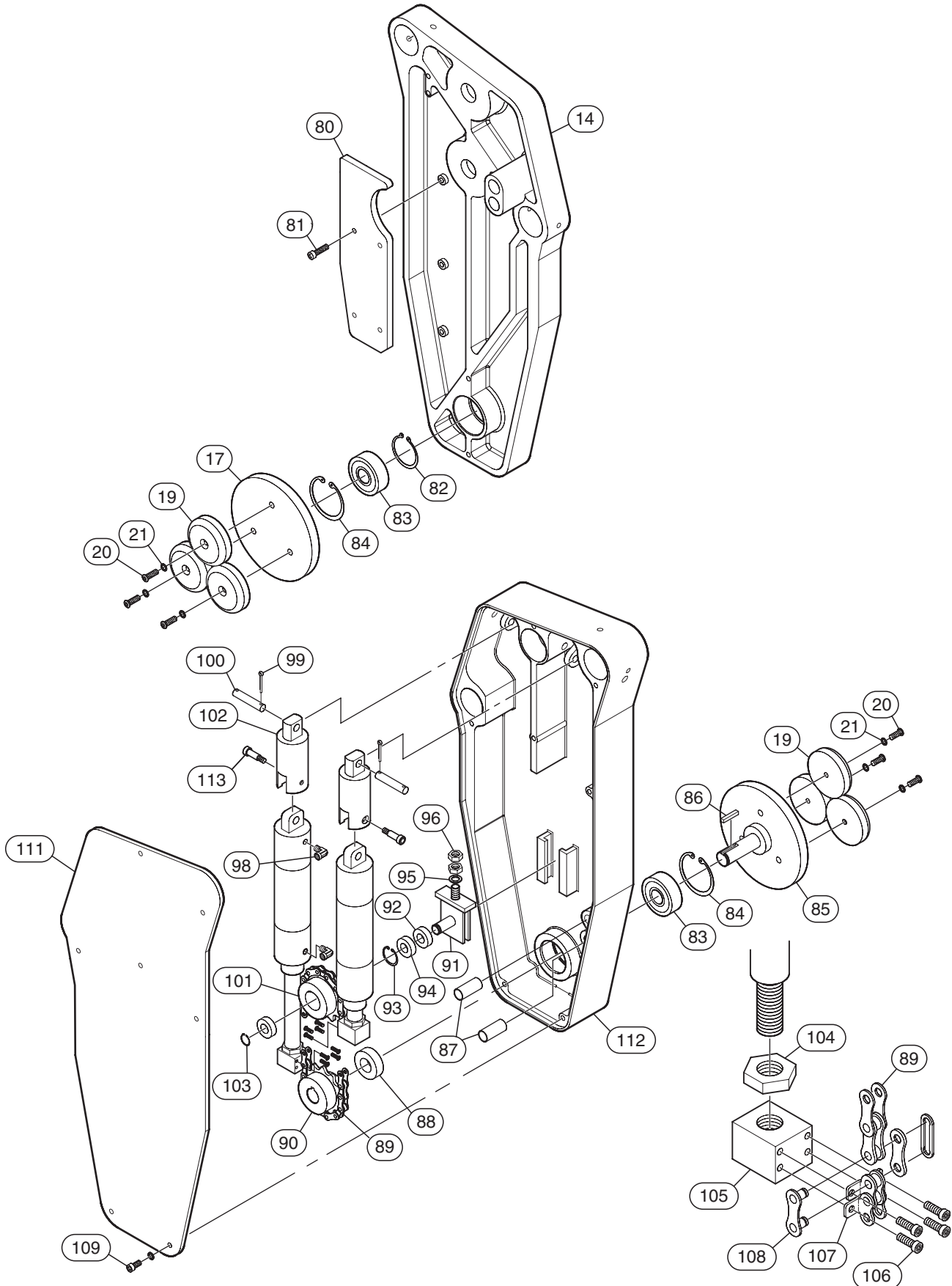

(Dwg. MHP2404)

POWER ROTATE PADDLE ASSEMBLY PARTS LIST

Item No.	Description of Part	Qty Total	Part Number	Item No.	Description of Part	Qty Total	Part Number
14	Paddle LH	1	97523	94	Bearing	1	65012
17	Bumper Mount	1	95483-94	95	Washer	1	74508
19	Bumper	6	93096	96	Locknut	2	75542
20	Capscrew	6	70919	97	Cylinder (2 x 3.75)	2	60750
21	Washer	6	74529	98	Fitting, Elbow	4	93970
80	Counterweight	1	95872	99	Cotter Pin	2	*
81	Capscrew	4	15782	100	Pin	2	95483-8
82	Retainer Ring	1	65053	101	Sprocket	1	99001
83	Bearing	2	65043	102	Clevis	2	96168
84	Retainer Ring	2	65051	103	Retainer Ring	1	65052
85	Bumper Mount, Power Rotate	1	95483-4	104	Locknut	2	60751
86	Key	1	3/16 sq x 1 in.	105	Chain Tension Block	2	95483-5
87	Bushing	2	65046	106	Capscrew	8	70011
88	Spacer	1	95483-6	107	Chain Link Attachment	2	99003
89	Chain	1	99005	108	Master Link	3	99006
90	Sprocket	1	99002	109	Capscrew	7	70402
91	Tension Plate	1	95483-7	111	Cover	1	97524
92	Spacer	1	95483-3	112	Paddle, Power Rotate RH	1	97521
93	Retainer Ring	1	65050	113	Capscrew	2	71445

* Contact factory

SELF RETRACTING LEVELING PAD ASSEMBLY PARTS DRAWING

For 34 to 50 inch (864 to 1270 mm) bundles

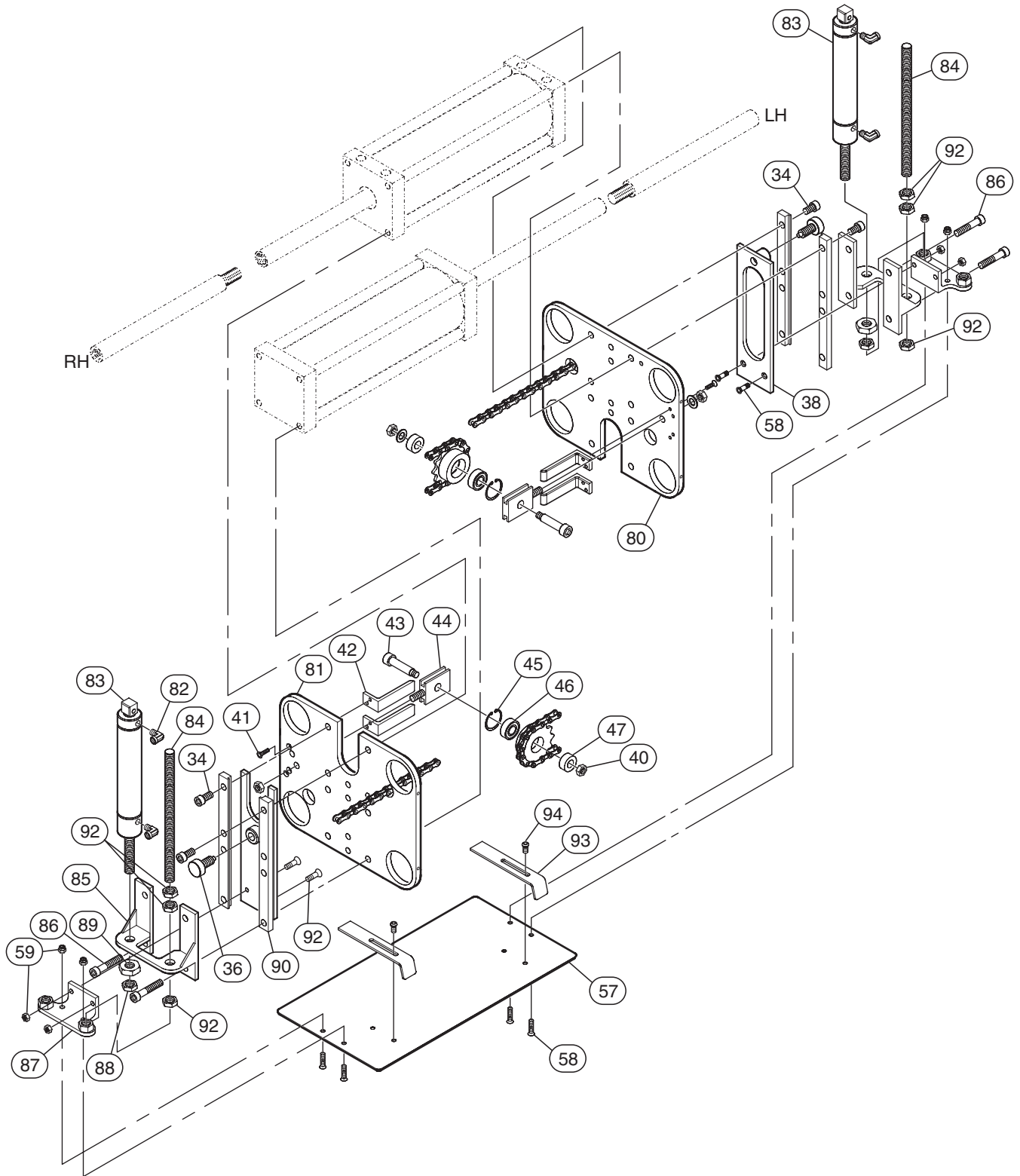

(Dwg. MHP2285)

SELF RETRACTING LEVELING PAD ASSEMBLY PARTS LIST

Item No.	Description of Part	Qty Total	Part Number	Item No.	Description of Part	Qty Total	Part Number
34	Capscrew	8	71473	80	End Plate LH	1	98038002
36	Plunger	2	*	81	End Plate RH	1	98038001
38	Side Guide LH	1	54034947	82	Fitting, Connector	4	93970
40	Locknut	4	75511	83	Cylinder	2	12475DP
41	Screw	8	70219	84	Threaded Rod	2	*
42	Tension Block Bracket	4	95483031	85	Cylinder Mount Bracket	2	66447030D01
43	Shoulder Screw	2	72006	86	Capscrew	8	*
44	Tension Block	2	95483012	87	Platform Bracket	2	66447030D02
45	Retainer Ring	2	65050	88	Jam Nut	2	75553
46	Bearing	2	65012	89	Nut	2	D-3556
47	Spacer	2	95483019	90	Side Guide	4	61871020
57	Platform	1	95483036	92	Locknut	6	75558
58	Screw	8	70446	93	Edge Locator	2	66447030D03
59	Nut	8	75503	94	Screw	4	70423
64	Side Guide RH	1	54035746				

* Contact factory

SCHEMATIC PARTS LIST

Item No.	Description of Part	Qty Total	Part Number	Item No.	Description of Part	Qty Total	Part Number
1	Control Handle	1	18600	66	Fitting, Elbow	2	93978
3	Pressure Gauge	1	99152	67	Fitting, Elbow	1	01973
38	Cylinder	1	60604	68	Fitting, Branch 'Y'	1	93982
50	Valve	2	93849	69	Pilot Valve, 4 Way	1	93851
51	Bulkhead Union	1	93959	70	Fitting, Nipple	1	10370
52	Bulkhead Connection	1	93955	71	Fitting, Connector	1	93963
53	Fitting, Connector	1	93966	72	Coupling	1	10465
54	Coupling	1	10466	73	Fitting, Elbow	2	93979
55	Check Valve	1	13270	74	Button, Brass	2	93850
56	Fitting, Tee	1	10718	75	Quad-Coil Hose Assembly	1	93949
57	Fitting, Connector	2	93977	76	Tube, Black 3/8 in.	As Req'd	93980-B
58	Fitting, Elbow	6	93969	77	Tube, Yellow 3/8 in.	As Req'd	93980-Y
59	Interlock Valve	1	99064	78	Tube, Clear 3/8 in.	As Req'd	93980-C
60	Fitting, Elbow	2	93970	79	Tube, Red 3/8 in.	As Req'd	93980-R
61	Fitting, Elbow	3	10375	80	Tube, Green 1/4 in.	As Req'd	93961-G
62	Fitting, Nipple	1	10731	81	Tube, Green 5/32 in.	As Req'd	93960-G
63	Fitting, Tee	3	01964	82	Tube, Yellow 5/32 in.	As Req'd	93960-Y
64	Pilot Valve, 4 Way	1	99099	83	Tube, Black 5/32 in.	As Req'd	93960-BK
65	Muffler	2	90333	84	Tube, White 5/32 in.	As Req'd	93960-W

SCHEMATIC PARTS DRAWING

Dual Controls, Power Rotate Bundle Handler With Balancer

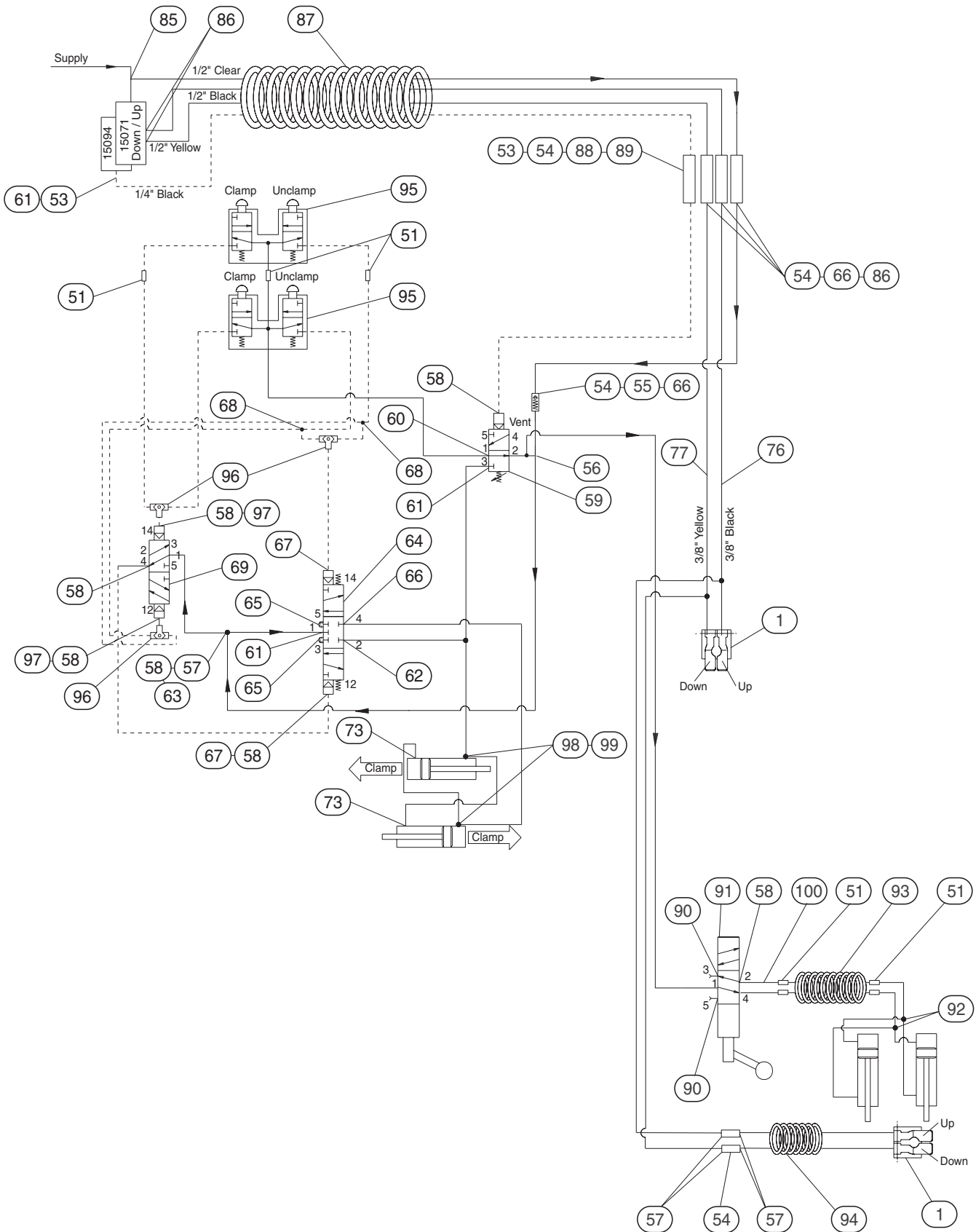

(Dwg. MHP2217)

SCHEMATIC PARTS DRAWING AND LIST

Item No.	Description of Part	Qty Total	Part Number	Item No.	Description of Part	Qty Total	Part Number
1	Control Handle	2	18600	79	Tube, Red 3/8 in.	As Req'd	93980-R
51	Bulkhead Union	7	93956	80	Tube, Green 1/4 in.	As Req'd	93961-G
53	Fitting, Connector	2	93966	81	Tube, Green 5/32 in.	As Req'd	93960-G
54	Coupling	7	10466	82	Tube, Yellow 5/32 in.	As Req'd	93960-Y
55	Check Valve	1	13270	83	Tube, Black 5/32 in.	As Req'd	93960-BK
56	Fitting, Tee	1	10718	84	Tube, White 5/32 in.	As Req'd	93960-W
57	Fitting, Connector	7	93977	85	Fitting, Tee	1	10708
58	Fitting, Elbow	9	93969	86	Fitting, Adapter	5	10703
• 59	Interlock Valve	1	99064	87	Quad Coil	1	93950-A
60	Fitting, Elbow	4	93970	88	Fitting, Connector	1	93964
61	Fitting, Elbow	6	10375	89	Fitting, Adapter	1	10376
62	Fitting, Nipple	1	10731	90	Vent	2	90334
63	Fitting, Tee	3	01964	91	4 Way Lever Valve	1	99092
• 64	Pilot Valve, 4 Way	1	99099	92	Union	2	99159
65	Muffler	2	90333	93	Precoil Hose 5/32 in. Orange	1	93945
66	Fitting, Elbow	6	93978	94	Precoil Hose 3/8 in. Yellow	1	93951-Y
67	Fitting, Elbow	2	01973		Precoil Hose 3/8 in. Black	1	93951-B
68	Fitting, Branch 'Y'	2	93982	95	EZ Grip Control	2	18621
• 69	Pilot Valve, 4 Way	1	93851	96	Shuttle Valve	3	90397
73	Fitting, Swivel Elbow	2	93979	97	Bushing	2	13501
75	Quad-Coil Hose Assembly	1	93950	98	Branch 'Y'	2	93992
76	Tube, Black 3/8 in.	As Req'd	93980-B	99	Fitting, Elbow	2	10354
77	Tube, Yellow 3/8 in.	As Req'd	93980-Y	100	Tube, Blue 5/32 in.	1	93960-B
78	Tube, Clear 3/8 in.	As Req'd	93980-C				

• Recommended Spare

PARTS ORDERING INFORMATION

Bundle Handlers are designed and constructed to provide long, trouble-free service. In time it may become necessary to order and install new parts to replace those that have been subjected to wear.

The use of replacement parts other than **Ingersoll-Rand** may result in decreased performance, and may, at the company's option invalidate the warranty.

For prompt service and genuine **Ingersoll-Rand** parts, provide your nearest Distributor with the following:

1. Complete Model description.
2. Part number and part description as shown in this manual.
3. Quantity required.

For your convenience and future reference it is recommended that the following information be recorded:

Model Description _____

Date Purchased _____

Serial Number _____

Return Goods Policy

Ingersoll-Rand will not accept any returned goods for warranty or service work unless prior arrangements have been made and written authorization has been provided from the location where the goods were purchased.

NOTICE

• **Continuing improvement and advancement of design may produce changes to this unit which are not included in this manual. Manuals are periodically revised to incorporate changes. Always check the manual edition number on the front cover for the latest issue.**

Disposal

When the life of the unit has expired, it is recommended that the air motor be disassembled, degreased and parts separated as to materials so that they may be recycled.

For additional information contact:

**Ingersoll-Rand
Zimmerman Handling Systems**
1872 Enterprise Drive
Rochester Hills, MI 48309
Phone: (248) 293-5700
Fax: (248) 293-5800

or

**Ingersoll-Rand
Douai Operations**
111, Avenue Roger Salengro
59450 Sin Le Noble, France
Phone: (33) 3-27-93-08-08
Fax: (33) 3-27-93-08-08

For additional information on the following products order the publication by the referenced Part/Document Number listed:

Publication	Part/Document Number	Publication	Part/Document Number
Z-Balancer	MHD56151	Z-Rail System	MHD56159
Manipulator Arm	MHD56162	Valu-Trak Rail System	MHD56161

LIMITED WARRANTY

Ingersoll-Rand Company (I-R) warrants to the original user its Products to be free of defects in material and workmanship for a period of one year from the date of purchase. **I-R** will repair, without cost, any Product found to be defective, including parts and labor charges, or at its option, will replace such Products or refund the purchase price less a reasonable allowance for depreciation, in exchange for the Product. Repairs or replacements are warranted for the remainder of the original warranty period.

If any Product proves defective within its original one year warranty period, it should be returned to any Authorized **I-R** Material Handling Service Distributor, transportation prepaid with proof of purchase or warranty card.

This warranty does not apply to Products which **I-R** has determined to have been misused or abused, improperly maintained by the user, or where the malfunction or defect can be attributed to the use of non-genuine **I-R** parts.

I-R makes no other warranty, and all implied warranties including any warranty of merchantability or fitness for a particular purpose are limited to the duration of the expressed warranty period as set forth above. I-R's maximum liability is limited to the purchase price of the Product and in no event shall I-R be liable for any consequential, indirect, incidental, or special damages of any nature rising from the sale or use of the Product, whether based on contract, tort, or otherwise.

Note: Some states do not allow limitations on incidental or consequential damages or how long an implied warranty lasts so that the above limitations may not apply to you.

This warranty gives you specific legal rights and you may also have other rights which may vary from state to state.

IMPORTANT NOTICE

It is our policy to promote safe delivery of all orders.

This shipment has been thoroughly checked, packed and inspected before leaving our plant and receipt for it in good condition has been received from the carrier. Any loss or damage which occurs to this shipment while en route is not due to any action or conduct of the manufacturer.

Visible Loss or Damage

If any of the goods called for on the bill of lading or express receipt are damaged or the quantity is short, do not accept them until the freight or express agent makes an appropriate notation on your freight bill or express receipt.

Concealed Loss or Damage

When a shipment has been delivered to you in apparent good condition, but upon opening the crate or container, loss or damage has taken place while in transit, notify the carrier's agent immediately.

Damage Claims

You must file claims for damage with the carrier. It is the transportation company's responsibility to reimburse you for repair or replacement of goods damaged in shipment. Claims for loss or damage in shipment must not be deducted from the **Ingersoll-Rand** invoice, nor should payment of **Ingersoll-Rand** invoice be withheld awaiting adjustment of such claims as the carrier guarantees safe delivery.

You may return products damaged in shipment to us for repair, which services will be for your account and form your basis for claim against the carrier.

United States Office Locations

Technical Support

**Ingersoll-Rand
Zimmerman Handling
Systems**
1872 Enterprise Drive
Rochester Hills, MI 48309
Phone: (248) 293-5700
Fax: (248) 293-5800

For Order Entry and Order Status:

**Ingersoll-Rand
Global Logistics**
P.O. Box 618
510 Hester Drive
White House, TN 37188
Phone: (866) 474-8665
Fax: (615) 672-0854

Web Site:

www.irco.com

Regional Sales Offices

Annandale, NJ
P.O. Box 970
1467 Route 31 South
Annandale, NJ 08801
Phone: (908) 238-7000
Fax: (908) 238-7048

International Office Locations

Offices and distributors in principal cities throughout the world. Contact the nearest **Ingersoll-Rand** office for the name and address of the distributor in your country or write/fax to:

Canada National Sales Office Regional Warehouse Toronto, Ontario

51 Worchester Road
Rexdale, Ontario
M9W 4K2
Phone: (416) 213-4500
Fax: (416) 213-4510
Order Desk
Fax: (416) 213-4506

Latin America Operations

Ingersoll-Rand
730 N.W. 107 Avenue
Suite 300, Miami, FL
33172-3107
Phone: (305) 559-0500
Fax: (305) 222-0864

Europe, Middle East and Africa

**Ingersoll-Rand
Douai Operations**
111, avenue Roger Salengro
59450 Sin Le Noble, France
Phone: (33) 3-27-93-08-08
Fax: (33) 3-27-93-08-00

Asia Pacific Operations

Ingersoll-Rand Ltd.
42 Benoi Road
Jurong, Singapore 629903
Phone: 65-861-1555
Fax: 65-862-1373

Russia

Ingersoll-Rand
Kuznetsky Most 21/5
Entrance 3
Moscow 103895 Russia
Phone: (7) 501 923 9134
Fax: (7) 501 924 4625