

INSTRUCTIONS AND PARTS LIST CRANE BRIDGE KITS 1/4 THRU 5 TON PUSH, HAND GEARED AND MOTOR DRIVEN

TO BUILD UNDERHUNG CRANE BRIDGES

THE INFORMATION CONTAINED IN THIS MANUAL IS FOR INFORMATIONAL PURPOSES ONLY AND COLUMBUS MCKINNON CORPORATION DOES NOT WARRANT OR OTHERWISE GUARANTEE (IMPLIEDLY OR EXPRESSLY) ANYTHING OTHER THAN THE COMPONENTS THAT COLUMBUS MCKINNON CORPORATION MANUFACTURES AND ASSUMES NO LEGAL RESPONSIBILITY (INCLUDING, BUT NOT LIMITED TO CONSEQUENTIAL DAMAGES) FOR INFORMATION CONTAINED IN THIS MANUAL.

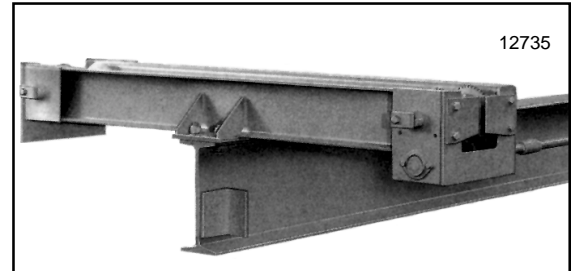

Figure 1.

GENERAL

These crane bridge kits contain all parts needed, except the bridge beam, cross shaft (when required), and the trolley stop angles to build top running, single girder crane bridges in rated loads and spans (center-to-center distance between runway beams) charted below.

SIZES OF BRIDGES THAT CAN BE BUILT WITH THESE KITS

(**) BEAM SIZES FOR VARIOUS SPANS									
Spans To	(*) RATED LOAD IN TONS								Spans To
	1/4	1/2	1	1-1/2	2	3	4	5	
Push or Hand Geared Crane									
10 ft.	S 6x12.5	S 6x12.5	S 6x12.5	S 8x18.4	S 10x25.4	S 12x40.8	S 12x40.8	S 12x40.8	10 ft.
12 ft.	S 6x12.5	S 6x12.5	S 7x15.3	S 10x25.4	S 10x25.4	S 12x40.8	S 12x40.8	S 18x54.7	12 ft.
14 ft.	S 6x12.5	S 6x12.5	S 7x15.3	S 10x25.4	S 12x31.8	S 12x40.8	S 12x40.8	S 18x54.7	14 ft.
16 ft.	S 6x12.5	S 7x15.3	S 8x18.4	S 10x25.4	S 12x31.8	S 12x40.8	S 12x40.8	S 18x54.7	16 ft.
18 ft.	S 7x15.3	S 7x15.3	S 10x25.4	S 10x25.4	S 12x31.8	S 12x40.8	S 15x42.9	S 18x54.7	18 ft.
20 ft.	S 7x15.3	S 8x18.4	S 10x25.4	S 12x31.8	S 12x31.8	S 12x40.8	S 18x54.7	S 18x54.7	20 ft.
22 ft.	S 8x18.4	S 10x25.4	S 10x25.4	S 12x31.8	S 12x40.8	S 18x54.7	S 18x54.7	S 20x66	22 ft.
24 ft.	S 8x18.4	S 10x25.4	S 12x31.8	S 12x40.8	S 12x40.8	S 18x54.7	S 18x54.7	S 20x66	24 ft.
26 ft.	S 10x25.4	S 10x25.4	S 12x31.8	S 12x40.8	S 15x42.9	S 18x54.7	S 20x66	S 24x80	26 ft.
28 ft.	S 10x25.4	S 10x25.4	S 12x40.8	S 12x40.8	S 18x54.7	S 20x66	S 20x66	S 24x80	28 ft.
30 ft.	S 10x25.4	S 12x31.8	S 12x40.8	S 18x54.7	S 18x54.7	S 20x66	S 18x54.7 w/C 9x13.4	S 24x80	30 ft.
32 ft.	S 10x25.4	S 12x31.8	S 12x40.8	S 18x54.7	S 15x42.9 w/C 8x11.5	S 18x54.7 w/C 9x13.4	S 18x54.7 w/C 9x13.4	S 20x66 w/C 9x13.4	32 ft.
34 ft.	S 12x31.8	S 12x40.8	S 15x42.9	S 18x54.7	S 15x42.9 w/C 8x11.5	S 18x54.7 w/C 9x13.4	S 18x54.7 w/C 9x13.4	S 20x66 w/C 9x13.4	34 ft.
36 ft.	S 12x31.8	S 12x40.8	S 18x54.7	S 15x42.9 w/C 8x11.5	S 15x42.9 w/C 8x11.5	S 18x54.7 w/C 9x13.4	S 20x66 w/C 9x13.4	S 20x66 w/C 9x13.4	36 ft.
Motor Driven Crane									
10 ft.	S 6x12.5	S 6x12.5	S 6x12.5	S 10x25.4	S 10x25.4	S 12x40.8	S 12x40.8	S 12x40.8	10 ft.
12 ft.	S 6x12.5	S 6x12.5	S 7x15.3	S 10x25.4	S 12x31.8	S 12x40.8	S 12x40.8	S 18x54.7	12 ft.
14 ft.	S 6x12.5	S 6x12.5	S 7x15.3	S 10x25.4	S 12x31.8	S 12x40.8	S 12x40.8	S 18x54.7	14 ft.
16 ft.	S 6x12.5	S 7x15.3	S 8x18.4	S 10x25.4	S 12x31.8	S 12x40.8	S 18x54.7	S 18x54.7	16 ft.
18 ft.	S 7x15.3	S 8x18.4	S 10x25.4	S 12x31.8	S 12x31.8	S 18x54.7	S 18x54.7	S 20x66	18 ft.
20 ft.	S 7x15.3	S 8x18.4	S 10x25.4	S 12x31.8	S 12x40.8	S 18x54.7	S 18x54.7	S 20x66	20 ft.
22 ft.	S 8x18.4	S 10x25.4	S 12x31.8	S 12x40.8	S 12x40.8	S 18x54.7	S 20x66	S 20x66	22 ft.
24 ft.	S 10x25.4	S 10x25.4	S 12x31.8	S 12x40.8	S 18x54.7	S 20x66	S 20x66	S 24x80	24 ft.
26 ft.	S 10x25.4	S 10x25.4	S 12x40.8	S 18x54.7	S 18x54.7	S 20x66	S 18x54.7 w/C 9x13.4	S 24x80	26 ft.
28 ft.	S 10x25.4	S 12x31.8	S 12x40.8	S 18x54.7	S 12x40.8 w/C 8x11.5	S 18x54.7 w/C 9x13.4	S 18x54.7 w/C 9x13.4	S 20x66 w/C 9x13.4	28 ft.
30 ft.	S 10x25.4	S 12x31.8	S 12x40.8	S 18x54.7	S 12x40.8 w/C 8x11.5	S 18x54.7 w/C 9x13.4	S 18x54.7 w/C 9x13.4	S 20x66 w/C 9x13.4	30 ft.
32 ft.	S 12x31.8	S 12x40.8	S 18x54.7	S 12x40.8 w/C 8x11.5	S 15x42.9 w/C 8x11.5	S 18x54.7 w/C 9x13.4	S 18x54.7 w/C 10x15.3	S 20x66 w/C 9x13.4	32 ft.
34 ft.	S 12x40.8	S 12x40.8	S 18x54.7	S 15x42.9 w/C 8x11.5	S 15x42.9 w/C 8x11.5	S 18x54.7 w/C 9x13.4	S 20x66 w/C 9x13.4	S 20x66 w/C 9x13.4	34 ft.
36 ft.	S 12x40.8	S 12x40.8	S 12x31.8 w/C 9x13.4	S 15x42.9 w/C 8x11.5	S 15x42.9 w/C 8x11.5	S 18x54.7 w/C 20x20.7	S 20x66 w/C 9x13.4	S 20x66 w/C 12x20.7	36 ft.

* Rated load is based on maximum combined hoist and trolley weights of: 500 pounds for 1/4, 1/2 and 1 ton hoists; 1100 pounds for 1 1/2 and 2 ton hoists; 1600 pounds for 3 and 4 ton hoists; 2000 pounds for 5 ton hoists. Bridge designed in accordance with latest edition of CMAA Specification No. 74, using Lift-Tech trolleys.

** Beam sizes listed are American Standard I-Beam and Channel sections. Use ASTM A36 grade steel, first quality, free of rust and excessive mill scale.

SIZES OF BRIDGES THAT CAN BE BUILT WITH THESE KITS

(**) BEAM SIZES FOR VARIOUS SPANS									
Spans To	(*) RATED LOAD IN TONS								Spans To
	1/4	1/2	1	1-1/2	2	3	4	5	
Push or Hand Geared Crane									
10 ft.	W 6x12	W 6x12	W 8x15	W 10x19	W 12x22	W 10x30	W 14x38	W 18x46	10 ft.
12 ft.	W 6x12	W 6x12	W 8x15	W 10x19	W 12x22	W 12x35	W 18x40	W 18x46	12 ft.
14 ft.	W 6x12	W 6x12	W 8x15	W 10x19	W 10x26	W 12x35	W 18x40	W 18x46	14 ft.
16 ft.	W 6x12	W 8x15	W 8x18	W 10x26	W 14x26	W 14x38	W 16x45	W 16x50	16 ft.
18 ft.	W 8x15	W 8x18	W 8x18	W 10x26	W 10x30	W 18x40	W 16x45	W 18x55	18 ft.
20 ft.	W 8x15	W 8x18	W 8x21	W 10x26	W 10x30	W 18x40	W 18x46	W 16x57	20 ft.
22 ft.	W 8x18	W 8x18	W 10x26	W 10x30	W 14x34	W 12x45	W 16x50	W 16x57	22 ft.
24 ft.	W 8x18	W 8x21	W 10x26	W 10x30	W 12x35	W 16x45	W 16x50	W 16x57	24 ft.
26 ft.	W 8x21	W 10x22	W 10x30	W 12x35	W 14x38	W 14x48	W 14x53	W 18x60	26 ft.
28 ft.	W 10x22	W 10x26	W 10x30	W 14x38	W 12x40	W 14x48	W 16x57	W 18x65	28 ft.
30 ft.	W 10x22	W 10x26	W 14x34	W 12x40	W 14x43	W 14x53	W 18x65	W 18x71	30 ft.
32 ft.	W 10x26	W 10x30	W 12x35	W 14x43	W 14x48	W 18x60	W 16x67	W 16x77	32 ft.
34 ft.	W 10x26	W 12x30	W 14x38	W 14x48	W 14x48	W 18x65	W 16x67	W 16x77	34 ft.
36 ft.	W 10x30	W 14x34	W 12x40	W 14x48	W 14x53	W 16x67	W 16x77	W 16x89	36 ft.
Motor Driven Crane									
10 ft.	W 6x12	W 6x12	W 8x15	W 10x19	W 12x22	W 12x35	W 18x40	W 18x46	10 ft.
12 ft.	W 6x12	W 6x12	W 8x15	W 10x19	W 10x26	W 12x35	W 18x40	W 18x46	12 ft.
14 ft.	W 6x12	W 6x12	W 8x18	W 10x26	W 14x26	W 14x38	W 10x45	W 16x50	14 ft.
16 ft.	W 6x12	W 8x15	W 8x18	W 10x26	W 10x30	W 18x40	W 16x45	W 14x53	16 ft.
18 ft.	W 8x15	W 8x18	W 8x21	W 10x26	W 10x30	W 18x40	W 18x46	W 16x57	18 ft.
20 ft.	W 8x18	W 8x18	W 8x21	W 10x30	W 10x30	W 10x45	W 12x50	W 16x57	20 ft.
22 ft.	W 8x18	W 8x21	W 10x26	W 10x30	W 12x35	W 16x45	W 16x50	W 16x57	22 ft.
24 ft.	W 8x18	W 8x21	W 10x26	W 14x34	W 14x38	W 14x48	W 14x53	W 18x65	24 ft.
26 ft.	W 8x21	W 10x26	W 10x30	W 12x35	W 12x40	W 12x50	W 16x57	W 18x65	26 ft.
28 ft.	W 10x22	W 10x26	W 10x33	W 12x40	W 12x40	W 14x53	W 18x65	W 18x71	28 ft.
30 ft.	W 10x26	W 10x30	W 12x35	W 12x40	W 12x45	W 14x53	W 16x67	W 14x74	30 ft.
32 ft.	W 10x26	W 10x30	W 14x38	W 12x45	W 14x48	W 14x61	W 16x67	W 16x77	32 ft.
34 ft.	W 10x30	W 14x34	W 12x40	W 14x48	W 14x53	W 16x67	W 16x67	W 16x89	34 ft.
36 ft.	W 10x30	W 12x35	W 12x40	W 14x53	W 14x61	W 16x67	W 16x77	W 16x89	36 ft.

* Rated load is based on maximum combined hoist and trolley weights of: 500 pounds for 1/4, 1/2 and 1 ton hoists; 1100 pounds for 1½ and 2 ton hoists; 1600 pounds for 3 and 4 ton hoists; 2000 pounds for 5 ton hoists. Bridge designed in accordance with latest edition of CMAA Specification No. 74, using Lift-Tech trolleys.

** Beam sizes listed are American Standard I-Beam and Channel sections. Use ASTM A36 grade steel, first quality, free of rust and excessive mill scale.

Catalog Numbers Required to Build a Push Crane

For Spans Thru (ft)	Rated Load Range (tons)	1 Pair of End Trucks (Catalog Number)
36	1/4 thru 3	905368
	1/4 thru 5	905524

Catalog Numbers Required to Build a Hand Geared Crane

For Spans Thru (ft)	Rated Load Range (tons)	Catalog Number for 1 Pair of End Trucks (Cat. No. 905369 for 1/4 thru 3 ton or Cat. No. 905525 for 1/4 thru 5 tons). Chain Wheel and Guide (Cat No. 905371 which includes one cross shaft support and two cross shaft couplings) and Hand Chain (Cat. No. 8282 which includes 36 ft. of hand chain).	Cross Shaft Support		Cross Shaft Coupling	
			Number Req'd	Catalog Number	Number Req'd	Catalog Number
8	1/4 thru 3	905372	0	905373	0	905374
15			0		0	
22			1		0	
29			2		1	
36	1/4 thru 5	905527	3		1	

Catalog Numbers Required to Build a Motor Driven Crane

For Spans Thru (ft)	Rated Load Range (tons)	1 Pair of End Trucks (Catalog Number)	Cross Shaft Support		Cross Shaft Coupling		Gear Reducer			Motor		Control		Fused Disconnect Switch		
			Number Req'd	Catalog Number	Number Req'd	Catalog Number	10:1 Ratio (107 fpm)	15:1 Ratio (71 fpm)	20:1 Ratio (35 fpm)	208-230/460V	575V	208-230V	460V	575V	208-230V	460-575V
8	1/4 thru 3	905369	0	905373	2	905374	905376	905377	905378	905381	905382	905385	905386	905387	905388	905389
15			1		2											
22			2		2											
29	1/4 thru 5	905525	3	905525	3	905525	905525	905525	905525	905525	905525	905525	905525	905525	905525	905525
36			4		3											

Option:

Ballast Resistors: Catalog Number 905391 For 208-230V
 Catalog Number 905392 For 460V
 Catalog Number 905393 For 575V

Catalog Numbers Required for Optional Equipment

Trucks

Rated Load (tons)	Truck Type	Flange Width (in)	Specialty	Catalog Number
1/4 thru 3	Push	3-3/8 - 5-1/2	Standard	905368
		5-1/2 - 8	Wide Flange	905368W1
		8 - 10-1/2	Wide Flange	905368W2
		3-1/4	Patented Track	905368PT
		3 - 5-1/2	Spark Resistant	905368SR
1/4 thru 5	Push	4 - 6-3/8	Standard	905524
		6-3/8 - 9	Wide Flange	905524W1
		9 - 11-1/2	Wide Flange	905524W2
		3-1/4	Patented Track	905524PT
		4 - 6-3/8	Spark Resistant	905524SR
1/4 thru 3	Geared	3-3/8 - 5-1/2	Standard	905369
		5-1/2 - 8	Wide Flange	905369W1
		8 - 10-1/2	Wide Flange	905369W2
		3-1/4	Patented Track	905369PT
		3 - 5-1/2	Spark Resistant	905369SR
1/4 thru 5	Geared	4 - 6-3/8	Standard	905525
		6-3/8 - 9	Wide Flange	905525W1
		9 - 11-1/2	Wide Flange	905525W2
		3-1/4	Patented Track	905525PT
		4 - 6-3/8	Spark Resistant	905525SR

Bridge Brake

Voltage	Brake
120-240/1/60	905554
230-460/3/60	905555
575/3/60	905556

Bridge Bumpers	905390
-----------------------	--------

Fused Disconnect Switch

Voltage	Switch
208-230/3/60	905338
460-575/3/60	905389
120/1/60	905366
240/1/60	905367

Ballast Resistors

208-230V	460V	575V
905391	905392	905393

Two Speed Motors and Controls

Motor			115V Control		
208-230V	460V	575V	208-230V	460V	575V
905394	905395	905396	905397	905398	905399

Electronic Acceleration Control (208-230-460/3/60)	
Single Speed	904596
Two Speed	904598

Single Phase Motors and Controls

Motor	115V Control	
120-240V	120V	240V
905363	905364	905365

Air Motor Drive Package	904558
--------------------------------	--------

The proper catalog numbers must be ordered to build the crane required. For a push crane only one catalog number is required. Three are required for a hand geared crane and seven are required for a motor driven crane. Options are also available. Catalog numbers are shown on page 2.

3 ton end trucks have 4" diameter solid steel wheels (maximum allowable load is 4240 pounds per pair of wheels). 5 ton end trucks have 6-1/2" diameter solid steel wheels (maximum allowable load is 7520 pounds per pair of wheels). The 3 ton kit is good for rated loads from 1/4 thru 3 tons and 5 ton kit is good for rated loads from 1/4 thru 5 tons.

Rated Load (tons)	Minimum Recommended Runway Beam Flange	Maximum Recommended Runway Beam Flange		
		Beam	Flange	Beam
3 Ton Kit	3-3/8"	S 6x12.5	5-1/2"	S 14x42.9
5 Ton Kit	4"	S 8x18.4	6-3/8"	S 20x75.0

Runway beams must be properly designed to support bridge, hoist, trolley and rated load. Runway beams rails must be level and parallel within $\pm 1/8"$. Runway stops must be positioned to contact both ends of the crane simultaneously.

MATERIAL TO BE PURCHASED LOCALLY TO COMPLETE A CRANE BRIDGE

1. Bridge Beam. Obtain one length of American Standard Section I-Beam or Wide Flange Beam of the size recommended (see charts on page 1 and 2) for the rated load and span of bridge. The beam selected must be straight with flanges parallel to each other and flanges at 90 degrees to the web. See Figure 2. Where a channel is also required, the channel must be a minimum length of the span minus 4'-0".

Rated Load (tons)	Minimum Length of Beams Required
3 Ton Kit	Span + (1' - 4-1/2")
5 Ton Kit	Span + (1' - 6-3/4")

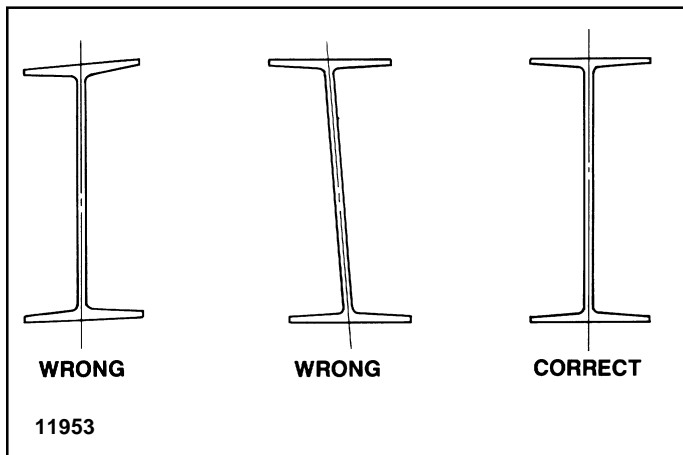

Figure 2. Correct Beam Selection.

2. Trolley Stops. Four (4) angles must be cut to size per Fig. 4.

⚠ WARNING
Improperly installed trolley stops (clip angles) can result in loss of bridge with resultant injury and damage.
TO AVOID INJURY AND DAMAGE: Install end stops on both ends of beams to prevent hoist trolley from running off end of beam. See Figure 4.

3. Cross Shaft. For hand geared and motor driven cranes, cross shafts are also required. The cross shafts are to be 1" diameter AISI 1018 cold drawn steel with a standard mill tolerance of +.000", -.002". For spans thru 22'-0", only one length of cross shaft is required. For spans over 22'-0", two lengths of cross shaft are required. One length is to be 14'-9". See table below for length. Shaft lengths may be equalized if care is taken to clear supports.

Rated Load (tons)	Cross Shaft Length Required If 1 Cross Shaft	Cross Shaft Length Required If 2 Cross Shaft
3 Ton Kit	Span - (2' - 4-1/4")	Span - (17' - 1-3/8")
5 Ton Kit	Span - (2' - 5-1/2")	Span - (17' - 2-5/8")

NOTICE

- A. All of the tables used in selection of structural steel beams have been produced by our engineering department using well established design guides for this type of crane bridge. IT IS IMPORTANT THAT ALL INSTRUCTIONS BE FOLLOWED AND THAT RECOMMENDED COMPONENT APPLICATION LIMITS NOT BE EXCEEDED.
- B. Assembly of beam and channel requires welding. IT IS EXTREMELY IMPORTANT TO THE SAFETY OF THIS BRIDGE THAT THIS WELDING BE DONE BY A COMPETENT WELL TRAINED WELDER. It is our strong recommendation that the welder used in this construction be qualified as prescribed by the American Welding Society (AWS) Specification for Welding Industrial and Mill Cranes D14.1-latest issue.

FABRICATION OF GIRDER FOR BRIDGE BEAM WITH CAPPING CHANNEL

Refer to Figure 3. Place channel on supports as shown in Step I. The I-beam is sighted for camber and placed with camber in direction shown in Step II. Weld one end of channel to the I-beam. Clamp, with "C" clamps, the channel to the I-beam flange - provide sufficient "C" clamps so as to hold channel in contact with the I-beam. Weld in accordance with the weld information given, starting at one end, staggering weld from side-to-side, proceeding to the opposite end without interruption. It is important to stagger weld from side-to-side in order to retain beam straightness. After welding, draw a taut string from end to end of beam as shown. Beam should either be parallel to string or have some camber. Camber should not exceed 1/800 of span.

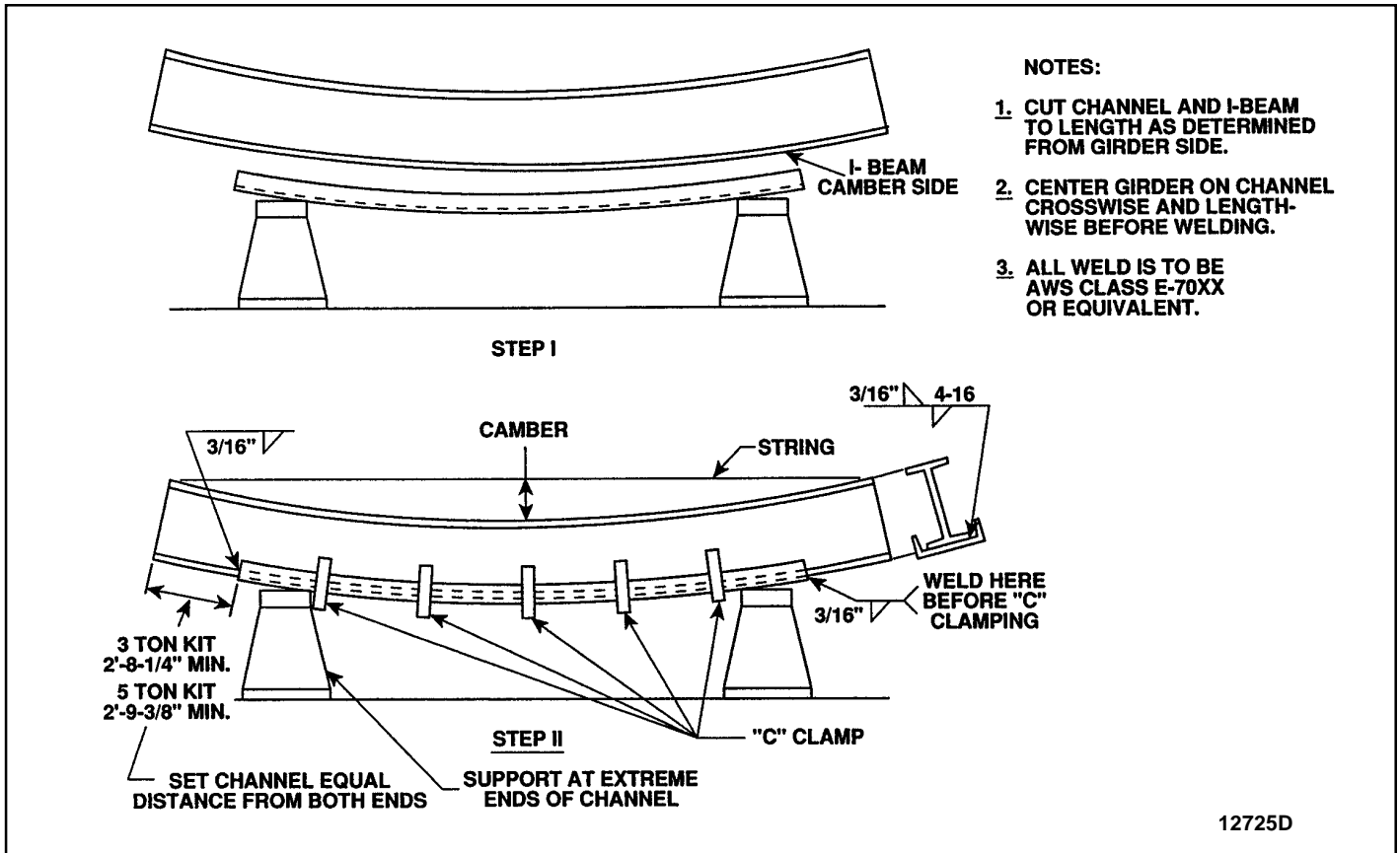

Figure 3.

INSTRUCTIONS FOR ASSEMBLING PUSH CRANE BRIDGE

- Set I-beam for bridge on a level surface, camber side up.
- Layout and scribe the centerline (over the web) of the flange at each end of the I-beam.
- Scribe lines 1-1/2" from the toe of truck plates near center of trucks as shown in Figure 4.
- Locate center of truck and layout and scribe lines locating center of truck as well as hole locations (centered on truck centerline) given by dimension A in Figure 4.
- Lay truck in position on I-beam. Line up I-beam and truck centerlines. For required length I-beam the toe of the truck will line up with the end of the I-beam. Greater than required length must be compensated for.
- Square trucks on top of I-beam and securely clamp in place. Check squareness by measuring and comparing the distances between the truck outside corners, diagonally across crane. These two diagonal measurements should be within 1/32" of each other.
- Check center to center of trucks. This may be done by measuring from the back of the inside truck plate on one end of the bridge to the back of the outside truck plate on the other end of the bridge. This should equal the span length.
- Drill 4 holes thru truck and beam flange at hole locations scribed at both ends of bridge. See table below for hole size.
- Assemble I-beam to trucks using bolts furnished with kit.

Rated Load (tons)	Hole Diameter	Bolt Diameter
3 Ton Kit	41/64"	5/8"
5 Ton Kit	49/64"	3/4"

Put one flat washer between bolt head and truck plate and put beveled washer against I-beam flange. Measure the distance between the beveled washer and the end of the bolt (bolt projection). If this distance is less than 1", discard the flat washer under the bolt head. If the distance is greater than 1-1/4", add a second flat washer under the bolt head. Add self-locking nut.

Tighten all bolts and nuts using the turn-of-nut method. This is done by alternately bringing bolts and nuts to a "snug-tight" condition to insure that mating surfaces are brought into full contact with each other. Then, make a final 1/2 turn on all bolts and nuts.

CAUTION

Do not substitute standard bolts and nuts for the special truck connecting bolts and nuts furnished with kit. Only high-strength bolts (S.A.E., grade 5) and elastic collared self-locking nuts, as furnished, are acceptable for attaching truck frames to bridge beam. High strength bolts are identified on the top of the head by three radial lines, equally spaced at 120 degrees. Self-locking nuts must have two threads, minimum extending thru nut. If necessary, discard flat washer to get two threads.

BRIDGE BEAM LENGTH = SPAN + F

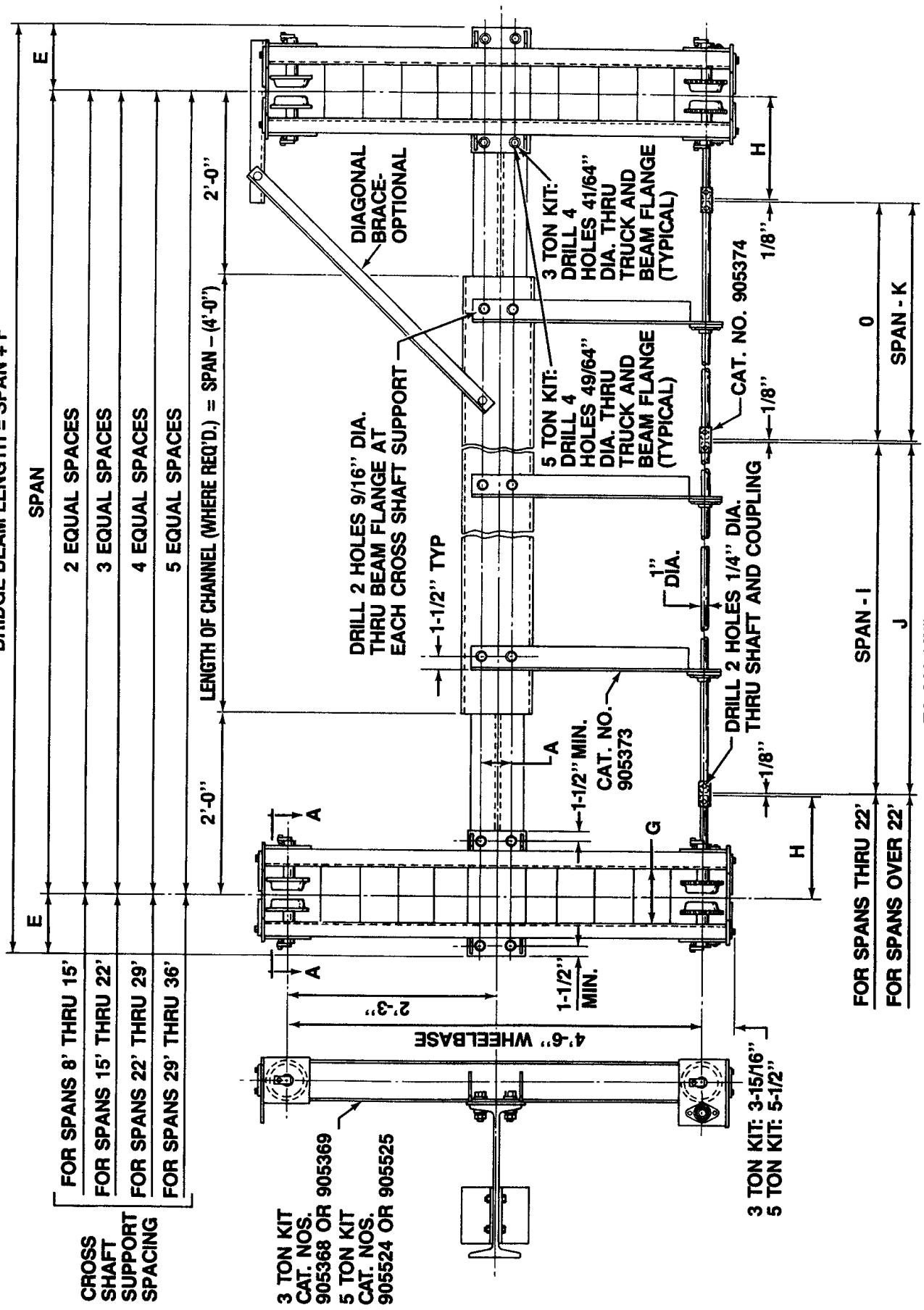

CROSS SHAFT SUPPORT SPACING

FOR SPANS 8' THRU 15'
FOR SPANS 15' THRU 22'
FOR SPANS 22' THRU 29'
FOR SPANS 29' THRU 36'

3 TON KIT
CAT. NOS.
905368 OR 905369

5 TON KIT
CAT. NOS.
905524 OR 905525

3 TON KIT: 3-15/16"
5 TON KIT: 5-1/2"

FOR SPANS THRU 22'
FOR SPANS OVER 22'

PLAN VIEW

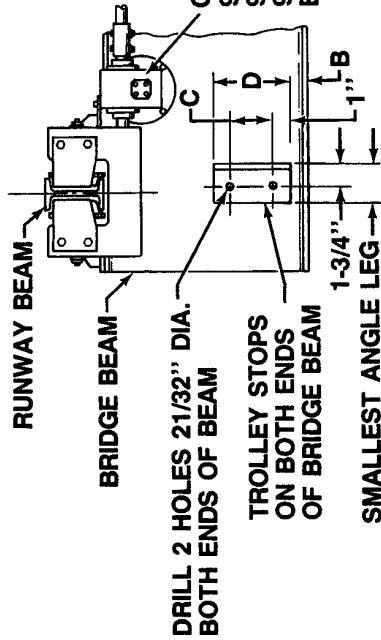

CAT. NOS.:
905376 THRU 905378 (GEAR REDUCERS)
905381 AND 905382 (MOTORS)
905385 THRU 905387 (ELECTRICAL
ENCLOSURES & MOUNTINGS—NOT SHOWN)

MOTOR DRIVEN CRANE

Trucks	E	F	G	H‡	I‡	J‡	K‡
905368, 905369	8-1/4"	1'-4-1/2"	7-5/8"	1'-2"	2'-4-1/4"	14'-9"	17'-1-3/8"
905368W1, 905369W1	9-1/2"	1'-7"	10-1/8"	1'-3-1/4"	2'-6-3/4"	14'-7-3/4"	17'-2-5/8"
905368W2, 905369W2	10-3/4"	1'-9-1/2"	1'-0-5/8"	1'-4-1/2"	2'-9-1/4"	14'-6-1/2"	17'-3-7/8"
905368PT, 905369PT	8-1/4"	1'-4-1/2"	7-5/8"	1'-2"	2'-4-1/4"	14'-9"	17'-1-3/8"
905368SR, 905369SR	8-1/4"	1'-4-1/2"	7-5/8"	1'-2"	2'-4-1/4"	14'-9"	17'-1-3/8"
905524, 905525	9-3/8"	1'-6-3/4"	8-7/8"	1'-2-5/8"	2'-5-1/2"	14'-9"	17'-2-5/8"
905524W1, 905525W1	10-11/16"	1'-9-3/8"	11-1/2"	1'-3-15/16"	2'-8-1/8"	14'-7-3/4"	17'-4"
905524W2, 905525W2	11-15/16"	1'-11-7/8"	1'-2"	1'-5-3/16"	2'-10-5/8"	14'-6-1/2"	17'-5-1/4"
905524PT, 905525PT	9-3/8"	1'-6-3/4"	8-7/8"	1'-2-5/8"	2'-5-1/2"	14'-9"	17'-2-5/8"
905524SR, 905525SR	9-3/8"	1'-6-3/4"	8-7/8"	1'-2-5/8"	2'-5-1/2"	14'-9"	17'-2-5/8"

‡ Applicable to geared trucks only.

Bridge Beam Flange Width	A	Trolley Stop Angle Size* (4 req'd.)	B	C	D
3-3/8"	2"	3 x 3 x 3/8	1"	2"	4"
3-5/8" thru 4"	2-1/4"	3-1/2 x 3 x 3/8	1"	3"	5"
4-5/8" thru 5-1/4"	2-3/4"	4 x 3 x 3/8**	1-1/2"	3"	5"
5-1/2" thru 6-3/4"	3-1/2"	5 x 3 x 3/8	1-3/4"	3"	5"
7" thru 7-5/8"	4"	6 x 4 x 3/8	1-3/4"	4"	6"

* Trolley frame or bumpers should contact trolley stops.

** Use 5 x 3 x 3/8 With W 12 x 40.8

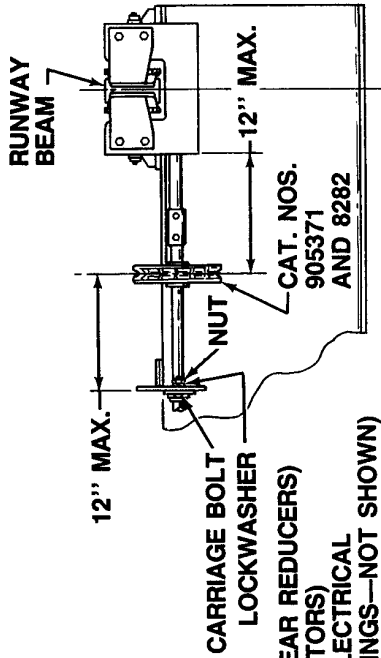

HAND GEARED CRANE

DIMENSIONS TO BE EQUAL

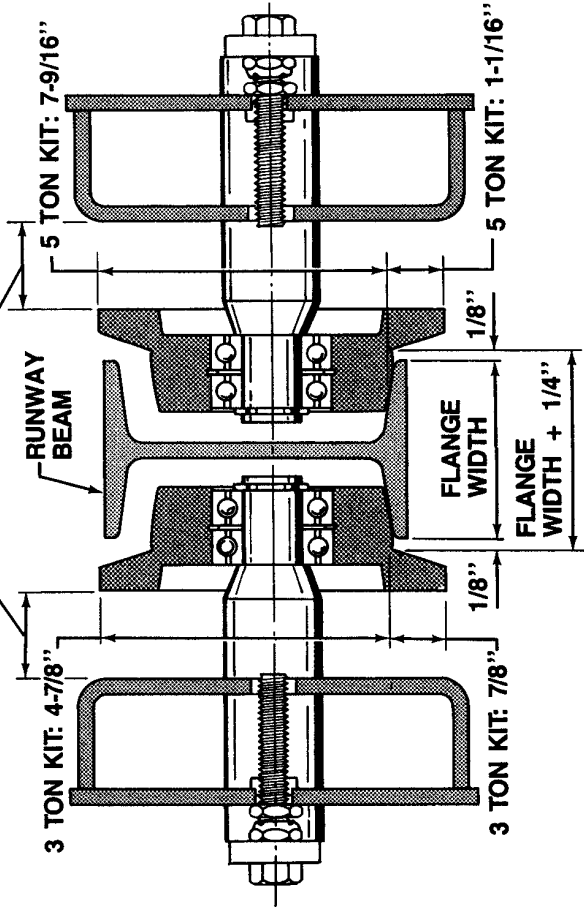

SECTION A-A (ENLARGED)

Figure 4.

10. Mount trolley stops to I-beam web in position shown in Figure 4. Stops may be welded or bolted in place. If bolted, drill holes using 21/32" diameter drill as indicated in Figure 4. 5/8" diameter bolts with self-locking nuts should be used to secure stops.

11. If it is desired to increase the rigidity of the bridge, four angles (one to each corner) may be added in the position shown as "Optional" (at 45° to the bridge I-beam) in Figure 4. On a motor driven crane it may be necessary to move the electrical enclosure for clearance reasons.

INSTRUCTIONS FOR ASSEMBLING HAND GEARED CRANE BRIDGE

1. Follow instructions for assembling push crane bridge.
2. Locate and drill holes for cross shaft supports.
3. Loosely bolt the cross shaft supports to the bridge beam. The flat washer goes under the bolt head and the beveled washer goes between the beam flange and the lockwasher and nut. The slotted plate spacer goes between the cross shaft support and the bridge beam unless the beam has a channel cap (see Figure 9). Discard the spacer if the beam has a channel cap.
4. Place the proper number of bearings and couplings on the cross shaft, set the unit in place and attach a flange bearing to each cross shaft support with two carriage bolts, lockwashers and hex nuts. The carriage bolt head locks in the bearing. Tighten set screws in bearings. The hand chain wheel and chain guide must also be placed on the cross shaft before placing. They may be positioned anywhere across the span, but must be within 12" of a cross shaft support or truck.
5. Check horizontal alignment of the cross shaft by using a taut line. Tighten cross shaft supports when alignment is complete.
6. Check the space between ends of cross shafts; it should be 1/8". Position the couplings and drill 1/4" diameter holes through the shaft and coupling using the holes in one side of the coupling as a guide. Shaft and coupling is secured by socket head cap screws with flat washers and self-locking hex nuts (see Figure 10).
7. Set position of hand chain wheel and chain guide (within 12" of cross shaft bracket or truck) with set screw on hand chain wheel. Determine length of operating hand chain (chain should hang about 2 feet 6 inches above floor), cut chain and make it endless by installing and closing open link furnished with chain.

INSTRUCTIONS FOR ASSEMBLING MOTOR DRIVEN CRANE BRIDGE

1. Follow instructions for assembling push crane bridge.
2. Locate and drill holes for cross shaft supports. It is allowable to use a drive on each truck and eliminate the cross shaft. In this case eliminate Steps 3, 7, 8 and 9.
3. Loosely bolt the cross shaft supports to the bridge beam. The flat washer goes under the bolt head and the beveled washer goes between the beam flange and the lockwasher and nut. The slotted plate spacer goes between the cross shaft support and the bridge beam unless the beam has a channel cap (see Figure 9). Discard the spacer if the beam has a channel cap.

4. Bolt the motor to the gear reducer with four hex head bolts and lockwashers and bolt the support plate to the gear reducer with two hex socket head cap screws and lockwashers. The drive may go on either end of the bridge.

5. Place key in truck drive shaft, slide gear reducer into place over shaft and bolt support plate to side of truck with two hex socket head cap screws and lockwashers. Maximum allowable torque is 10 pound feet. Tighten six set screws in gear reducer hollow shaft (Ref. No. 18 in Figure 12).

6. Using the 9/32" diameter hole in the support plate as a guide, drill a 5/16" diameter hole through the support plate and truck side and drive the groove pin, furnished, into the hole (Ref. No. 4 in Figure 12).

7. Place the proper number of bearings and couplings on the cross shaft, set the unit in place and attach a flange bearing to each cross shaft support with two carriage bolts, lockwashers and hex nuts. The carriage bolt head locks in the bearing (see Figure 9).

8. Check horizontal alignment of the cross shaft by using a taut line. Tighten cross shaft supports when alignment is complete.

9. Check the space between cross shafts; it should be 1/8". Position the couplings and drill 1/4" diameter holes through the shaft and coupling using the holes in one side of the coupling as a guide. Shaft and coupling is secured by socket head cap screws with flat washers and self-locking hex nuts (see Figure 10).

10. Mount electrical enclosure in holes on inside of truck over gear reducer (see Figure 13).

11. Mount fused disconnect switch in any safe, convenient location.

12. If ballast resistors (optional) are furnished, four holes are provided in the side of the electrical enclosure for mounting.

PAINTING

After assembly, all plain steel surfaces should be painted. Thoroughly clean surfaces of oily spots and rust using a suitable solvent. It is recommended that a national brand zinc-chromate primer be applied before a finish coat of high gloss enamel especially suited for steel surfaces.

MARKING

Codes require that the capacity of the bridge be shown on both sides of crane, legible from the floor. Normal practice for marking is to use capacity in tons, for example: 1 TON, 2 TON, etc. Stencil forms are readily available that may be used with brush-on or pressurized spray-can paint.

NOTICE

The crane builder and user are responsible for marking crane and also to check for compliance with all local, state and national codes.

INSTALLATION OF CRANE BRIDGE

⚠ WARNING

Working in or near exposed electrical equipment presents the danger of electric shock when installing crane on runway.

TO AVOID INJURY AND DAMAGE:

Lock the runway conductor disconnect switch in the open (off) position.

Note: Minimum runway beam size allows vertical clearance for bridge wheels between runway beam flanges. Encroachment of flange connections into this area may cause interference.

1. Open End Runway. If one end of the crane runway is open and no interference is encountered the crane bridge can be placed on the end of the runway. First check distance between wheels. The distance between the inside faces of the wheel flanges should be the width of the bottom flange of the runway beam plus 1/4". See Figure 5. Note also that the dimensions from the back of the wheels to the sides of the truck should be equal as shown in Figure 5. If wheel adjustment is required, see paragraph 5. If wheels do not require adjusting, lift crane bridge so that wheels are level with contact surface on runway beam. Carefully move crane bridge onto runway.

⚠ WARNING

When a crane bridge is mounted on a runway beam, the omission of properly installed end stops can result in loss of bridge with resultant injury and damage.

TO AVOID INJURY AND DAMAGE:

Install end stops.
End stops per trolley stop table in Figure 4 may be used and installed per instructions given.

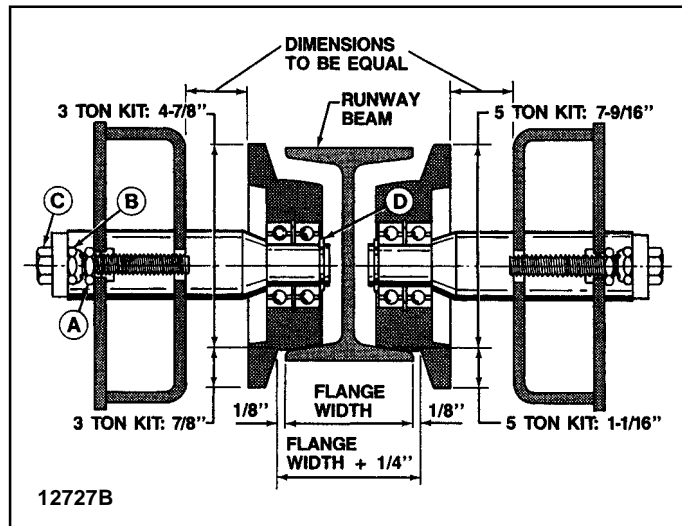

Figure 5.

2. Removable Runway Section. In some installations a removable section of runway may be available. If so, remove runway section, check crane bridge wheel adjustment and install crane bridge as in paragraph 1, and reinstall runway section.

3. Runway beam flange width 3-3/8" or less. Refer to Figure 5. Loosen jam nut "A" and self-locking nut "B". Back axle and wheel out against truck side by turning bolt "C". Lift crane bridge to runway level and secure. See paragraph 5 for wheel adjustment.

4. Wheel Removal. If the methods above are not possible, the crane bridge wheels must be removed. Refer to Figure 5. Loosen jam nut "A" and self-locking nut "B". Back axle and wheel out to truck side by turning bolt "C". Remove retaining ring "D". Hold wheel to keep from falling, back out bolt "C" until clear, and remove axle and wheel. Remove all wheels. Lift crane bridge to runway level and secure. Reinstall wheels in reverse order of removal. See paragraph 5 for wheel adjustment.

5. Wheel Adjustment. Measure the width of the bottom flange of the runway beam and add 1/4". This is to be the dimension between the inside faces of the wheel flanges as shown in Figure 5. Lift or jack up truck from runway beam (to remove weight from wheels) and adequately secure. Loosen jam nut "A" and self-locking nut "B" and adjust bolt "C" on a set of wheels to get the proper dimension between wheel flanges and to maintain equal dimensions from the back of the wheels to the side of the truck as shown in Figure 5. Securely tighten jam nut "A" and self-locking nut "B". After all wheels are adjusted, lower truck to runway and check clearance between wheel flange and edge of beam (1/8").

6. On a hand geared or a motor driven crane, loosen the two set screws holding each pinion in the geared truck. If LOCTITE has been used, some heat may be necessary to loosen set screws. Align the teeth of the pinions with the geared wheels and tighten the set screws.

NOTICE

It is recommended that for positive locking of the drive pinions (Figure 8, Ref. No. 25) on hand geared and motor driven end trucks, the following procedure be used (after wheel adjustment is complete).

- Make sure the area on the shaft under the drive pinions in their adjusted position is free from oil and dry. Use a suitable non-oily solvent or LOCTITE Safety Solvent 755.
- Align the teeth of the pinions with the geared wheels and lightly tighten the set screws which engage the pinion keys.
- Remove the other set screws and rotate the pinion shaft until these set screw holes are above horizontal.
- Apply LOCTITE 290 in the set screw holes until it can be seen flowing from the pinion bore at the shaft.
- Replace set screws and tighten fully. For maximum locking, use a **new**, high quality 1/8" hex key and apply pressure at the end of the longer arm until it bends about 30°.
- Loosen set screws over keys, apply a few drops of LOCTITE 290 and retighten as in Step E above.

7. When applicable follow National, State and Local electrical codes when providing electrical service to crane bridge. Make electrical connections according to the wiring diagrams furnished with the crane bridge. **Do not attempt to operate crane bridge before completing tests and adjustments.**

▲WARNING
Improper grounding may cause electrical shock to the operator.
<p style="text-align: center;">TO AVOID INJURY AND DAMAGE:</p> <p>This equipment must be effectively grounded according to applicable codes.</p> <p>Ordinarily the crane is grounded to the runway beam through contact with the wheels. Certain environments may prevent proper grounding by this means. In those cases, a 4th runway conductor should be provided to assure adequate grounding.</p> <p>This also applies to the cross conductors and the electrical contact between the trolley wheel and the bridge girder.</p>

FUSE AND MAINLINE DISCONNECT PANELS

Mainline disconnect panels and fuse bridge control panels are provided as options to assist users in complying with OSHA codes. When ordered with crane, they will be completely installed inside of electrical enclosures.

Electrical service is to be connected to crane equipped with fuse panels and mainline disconnect panels as shown in wiring diagram.

▲WARNING
Improper power supply can damage electrical components.
<p style="text-align: center;">TO AVOID INJURY AND DAMAGE:</p> <p>Power supply must be the same voltage, frequency and phase as specified on the crane motor nameplates.</p>

OPERATING PRECAUTIONS

▲WARNING
Supporting or transporting loads over people can result in injury.
<p style="text-align: center;">TO AVOID INJURY AND DAMAGE:</p> <p>Do not use these bridges for support or transport of people or for transporting loads over people.</p>

Safe operation of an overhead hoist is the operator's responsibility. Listed below are some basic rules that can make an operator aware of dangerous practices to avoid and precautions to take for his own safety and the safety of others. Observance of these rules in addition to frequent examinations and periodic inspection of the equipment may save injury to personnel and damage to equipment.

DO NOT load bridge beyond rated capacity.

DO NOT subject bridge to side loads. Always center trolley over load when hoisting.

DO NOT stand and **DO NOT** cause or allow others to stand or get under any load the bridge is supporting. **DO** keep clear, and make sure others keep clear, of any load the bridge is supporting.

DO NOT ram bridge into end stops, other bridge, or any obstruction on beam. Improper and careless operation can result in a hazardous condition for operator and load.

ALWAYS be sure load is clear of obstruction before traversing load.

If crane bridge is mounted on an open-end runway rail, then end stops must be installed to prevent crane bridge from running off the end of the runway rail resulting in injury to the operator and others and damages to load and other property. End stops per trolley stop table in Figure 4 may be used and installed per Instructions given.

Refer to hoist and trolley Instruction manuals for safety warnings on hoist and trolleys.

Read and comply with ANSI B30.11 Monorails and Underhung Cranes, latest edition.

Read and comply with all local, state and national safety codes.

MAINTENANCE AND LUBRICATION

1. Inspect the bridge on a regular maintenance schedule. Check to make sure wheel axle ADJUSTMENT bolts and all connections are tight. Check wheel tread surfaces for wear or damage. Check truck sides for any evidence of overload or damage. Replace any worn or damaged parts using only factory approved replacement parts.

2. Lubrication requirements:

- a. Wheel bearings are permanently lubricated and require no additional lubricant.
- b. Drive wheel gears are to be lubricated with an open type gear grease which is heavy, plastic, extreme pressure and tacky; such as MOBILTAC 275 or equal.
- c. The hollow shaft worm gear reducer lubricant should be changed every year or 2000 hours of service for moderate usage. The lubricant should be changed more frequently if the service is more severe. Use one pint of AGMA lubricant number 7, compounded, if the ambient temperature is 15° to 60°F or AGMA lubricant number 8, compounded, if the ambient temperature is 50° to 125° F.
- d. It is recommended that the areas of the cross shaft covered by gear reducers, bearings and couplings be coated with FEL-PRO C5-A, or equal, anti-seize lubricant.

Before crane operation the vent plug must be in the proper location in the gear reducer. The vent plug replaces the pipe plug in the highest location on the end of the gear reducer (see Figure 12).

REPLACEMENT PARTS

The following parts list and illustrations cover standard model cranes. Typical units are used as the basis for the exploded parts illustrations; therefore, certain variations may occur from the parts information given. For this reason always give the catalog number, model number, motor horsepower, voltage, phase and frequency when ordering replacement parts. For motors, gearboxes, and electrical components, give complete nameplate data.

The factory recommends complete replacement of the motor or gearbox. Gearbox service is available, however, from your local authorized repair station.

The numbers assigned to the parts of our various assemblies in our parts list are not the part numbers used in manufacturing the part. They are identification numbers, that when given with the catalog number, permit us to identify, select or manufacture and ship the correct part needed.

INDEX OF PARTS ILLUSTRATIONS		
Title	Figure No.	Page No.
Push Truck - Catalog Numbers 905368 and 905524	7	12
Geared Truck - Catalog Numbers 905369 and 905525	8	14
Cross Shaft Support - Catalog Number 905373	9	16
Coupling - Catalog Number 905374	10	17
Hand Chain Drive - Catalog Numbers 905371 and 8282	11	18
Gear Reducer (Catalog Numbers 905376 thru 905378 and Motor (Catalog Numbers 905381 and 905382	12	19
Electrical Enclosure and Mounting - Catalog Numbers 905385 and 905387	13	20

NOTES

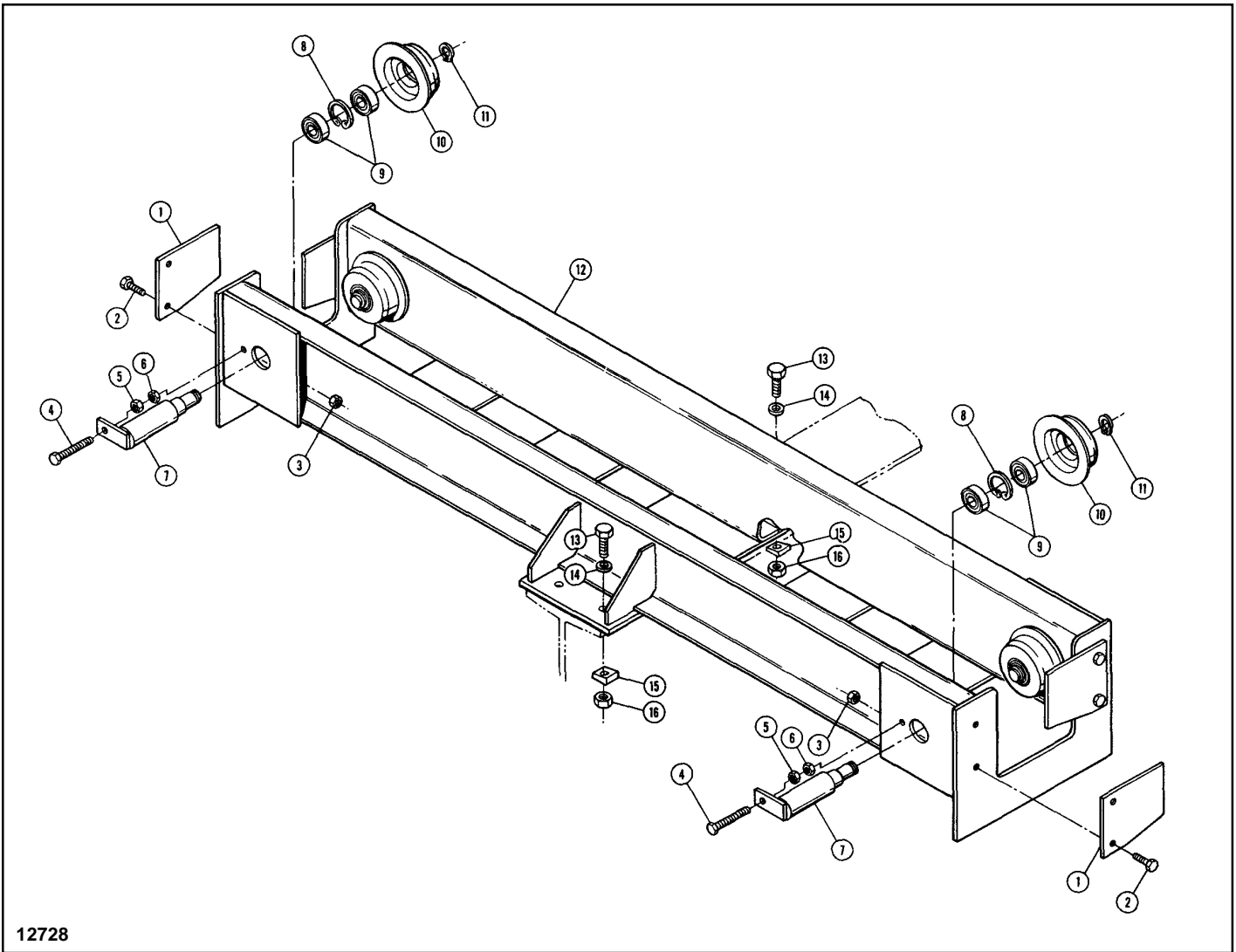

Figure 7. Push Truck. Catalog Numbers 905368 and 905524. (Only 1 Truck Shown)

Ref. No.	Part Number		Description	Qty. Req'd.
	905368	905524		
1	BTK-701	BTK-722	End Stop	4
2*	BTK-702	BTK-702	High Strength Hex Head Bolt - SAE Grade 5 (1/2-13 x 1-1/4)	8
3*	BTK-703	BTK-703	Heavy Hex Self-Locking Nut (1/2-13)	8
4	BTK-704	BTK-704	High Strength Hex Head Tap Bolt	4
5	BTK-705	BTK-705	Thin Hex Self-Locking Nut (1/2-13)	4
6	BTK-706	BTK-706	Hex Jam Nut (1/2-13)	4
7	BTK-707	BTK-723	Axle	4
8	BTK-708	BTK-724	Retaining Ring	4
9	BTK-709	BTK-725	Ball Bearing	8
10			Wheel	4
	BTK-710	BTK-726	Standard	
	BTK-717	BTK-727	Patented Track	
	BTK-718	BTK-728	Spark Resistant	
11	BTK-711	BTK-729	Retaining Ring	4

Figure 7. Push Truck. Catalog Numbers 905368 and 905524 (Continued).

Ref. No.	Part Number		Description	Qty. Req'd.
	905368	905524		
12	BTK-712	—	Truck Weldment For 3" Thru 5-1/2" Runway Beam Flange Width	1
	BTK-719	—	For 5-1/2" Thru 8" Runway Beam Flange Width	
	BTK-720	—	For 8" Thru 10-1/2" Runway Beam Flange Width	
	—	BTK-730	For 4" Thru 6-3/8" Runway Beam Flange Width	
	—	BTK-734	For 6-3/8" Thru 9" Runway Beam Flange Width	
	—	BTK-735	For 9" Thru 11-1/2" Runway Beam Flange Width	
13	BTK-713	—	High Strength Hex Head Bolt - SAE Grade 5 5/8-11 x 2-1/2	4
	—	BTK-736	3/4-10 x 2-3/4	
14	BTK-714	—	Plain Washer 5/8 Type N Pltd.	8
	—	BTK-731	Special	
15	BTK-715	BTK-732	Beveled Washer	4
16	BTK-721	BTK-733	Heavy Hex Self-Locking Nut	4

*On later model trucks Ref. No. 2 (new Part Number BTK-741 - 1/2-13 x 1) is now threaded into the end plate of the truck thus eliminating Ref. No. 3. A lock washer (not shown - Part Number BTK-740 - 1/2) is under the head of Ref. No. 2.

NOTES

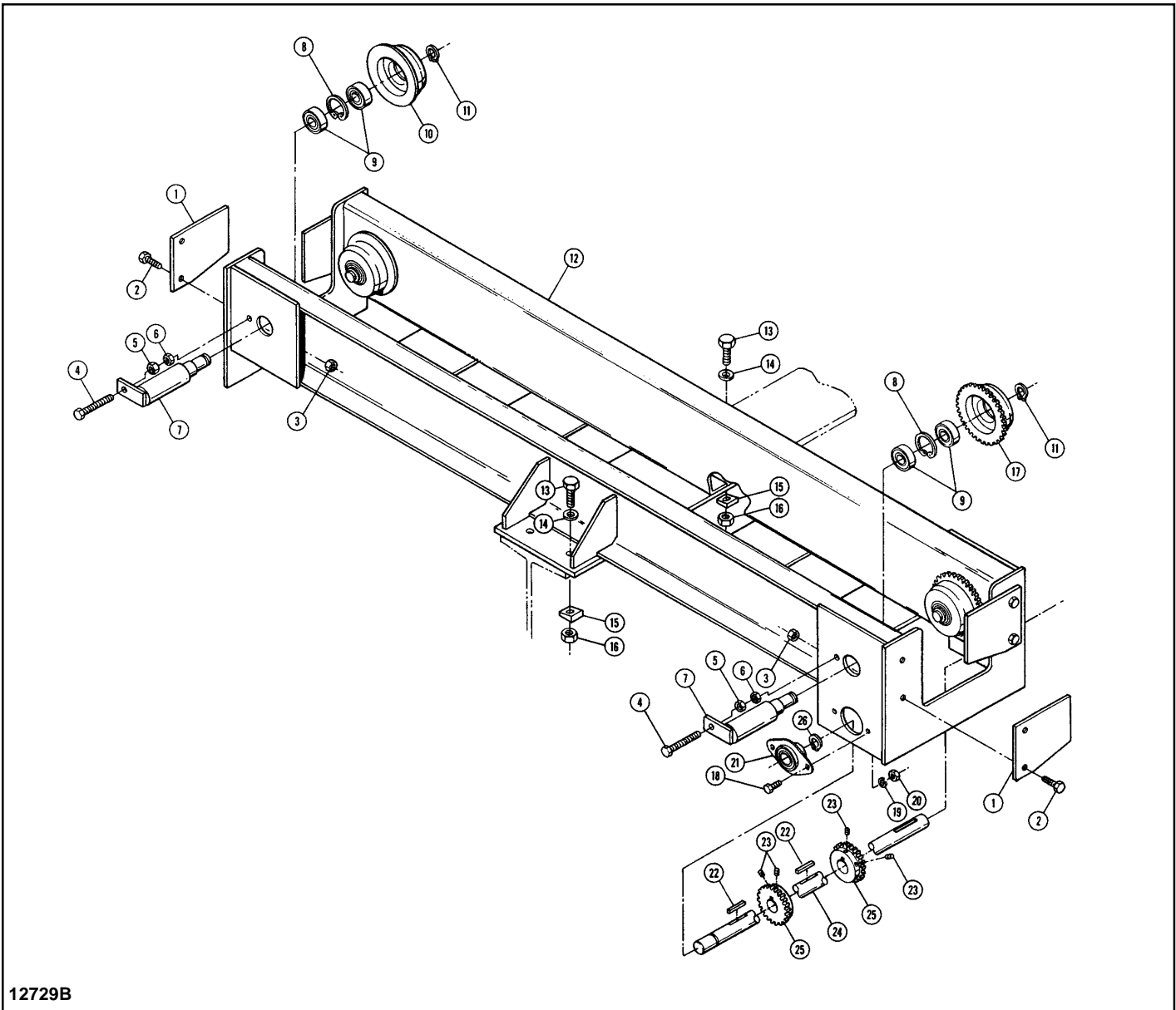

12729B

Figure 8. Geared Truck. Catalog Numbers 905369 and 905525. (Only 1 Truck Shown)

Ref. No.	Part Number		Description	Qty. Req'd.
	905369	905525		
1	BTK-801	BTK-837	End Stop	4
2*	BTK-802	BTK-802	High Strength Hex Head Bolt - SAE Grade 5 (1/2-13 x 1-1/4)	8
3*	BTK-803	BTK-803	Heavy Hex Self-Locking Nut (1/2-13)	8
4	BTK-804	BTK-804	High Strength Hex Head Tap Bolt	4
5	BTK-805	BTK-805	Thin Hex Self-Locking Nut (1/2-13)	4
6	BTK-806	BTK-806	Hex Jam Nut (1/2-13)	4
7	BTK-807	BTK-838	Axle	4
8	BTK-808	BTK-839	Retaining Ring	4
9	BTK-809	BTK-840	Ball Bearing	8
10			Plain Wheel	2
	BTK-810	BTK-841	Standard	
	BTK-826	BTK-842	Patented Track	
	BTK-827	BTK-843	Spark Resistant	
11	BTK-811	BTK-844	Retaining Ring	4

Figure 8. Geared Truck. Catalog Numbers 905369 and 905525 (Continued).

Ref. No.	Part Number		Description	Qty. Req'd.
	905369	905525		
12			Truck Weldment	1
	BTK-812	—	For 3" Thru 5-1/2" Runway Beam Flange Width	
	BTK-828	—	For 5-1/2" Thru 8" Runway Beam Flange Width	
	BTK-829	—	For 8" Thru 10-1/2" Runway Beam Flange Width	
	—	BTK-845	For 4" Thru 6-3/8" Runway Beam Flange Width	
	—	BTK-856	For 6-3/8" Thru 9" Runway Beam Flange Width	
	—	BTK-857	For 9" Thru 11-1/2" Runway Beam Flange Width	
13			High Strength Hex Head Bolt - SAE Grade 5	4
	BTK-813	—	5/8-11 x 2-1/2	
	—	BTK-858	3/4-10 x 2-3/4	
14			Plain Washer	8
	BTK-814	—	5/8 Type N Pltd.	
	—	BTK-846	Special	
15	BTK-815	BTK-847	Beveled Washer	4
16	BTK-830	BTK-848	Heavy Hex Self-Locking Nut	4
17			Geared Wheel	2
	BTK-817	BTK-849	Standard	
	BTK-831	BTK-850	Patented Track	
	BTK-832	BTK-851	Spark Resistant	
18	BTK-818	BTK-818	Hex Head Bolt (5/16-18 x 1-1/4)	4
19	BTK-819	BTK-819	Spring Lock Washer (5/16)	4
20	BTK-820	BTK-820	Hex Nut (5/16-18)	4
21	BTK-821	BTK-821	Flange Bearing	2
22	BTK-833	BTK-852	Square Key	2
23	BTK-823	BTK-853	Set Screw	4
24			Pinion Shaft	1
	BTK-824	—	For 3" Thru 5-1/2" Runway Beam Flange Width	
	BTK-834	—	For 5-1/2" Thru 8" Runway Beam Flange Width	
	BTK-835	—	For 8" Thru 10-1/2" Runway Beam Flange Width	
	—	BTK-854	For 4" Thru 6-3/8" Runway Beam Flange Width	
	—	BTK-859	For 6-3/8" Thru 9" Runway Beam Flange Width	
	—	BTK-860	For 9" Thru 11-1/2" Runway Beam Flange Width	
25	BTK-825	BTK-855	Pinion	2
26	BTK-836	BTK-836	Retaining Ring	1

*On later model trucks Ref. No. 2 (new Part Number BTK-871 - 1/2-13 x 1) is now threaded into the end plate of the truck thus eliminating Ref. No. 3. A lock washer (not shown - Part Number BTK-870 - 1/2) is under the head of Ref. No. 2.

NOTES

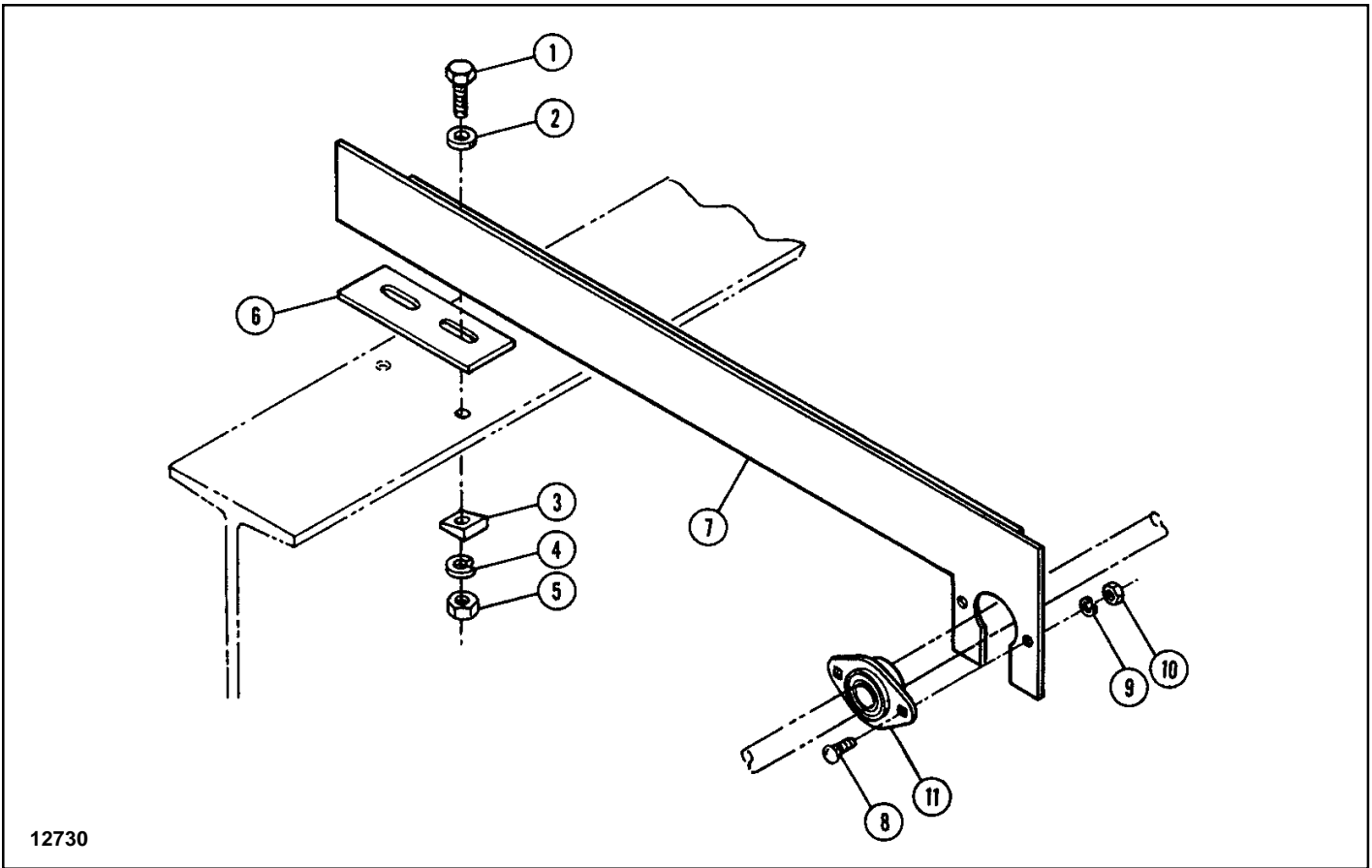

Figure 9. Cross Shaft Support. Catalog Number 905373.

Ref. No.	Part Number	Description	Qty. Req'd
1	BTK-901	Hex Head Bolt (1/2-13 x 2-1/4 Pltd.)	2
2	BTK-902	Plain Washer (Type N 1/2 Pltd.)	2
3	BTK-903	Beveled Washer	2
4	BTK-904	Spring Lock Washer (1/2 Pltd.)	2
5	BTK-905	Hex Nut (1/2-13 Pltd.)	2
6	BTK-906	Spacer	1
7	BTK-907	Cross Shaft Support	1
8	BTK-908	Round Head Square Neck Bolt (5/16-18 x 1 Pltd.)	2
9	BTK-909	Spring Lock Washer (5/16 Pltd.)	2
10	BTK-910	Hex Nut (5/16-18 Pltd.)	2
11	BTK-911	Flange Bearing	1

NOTES

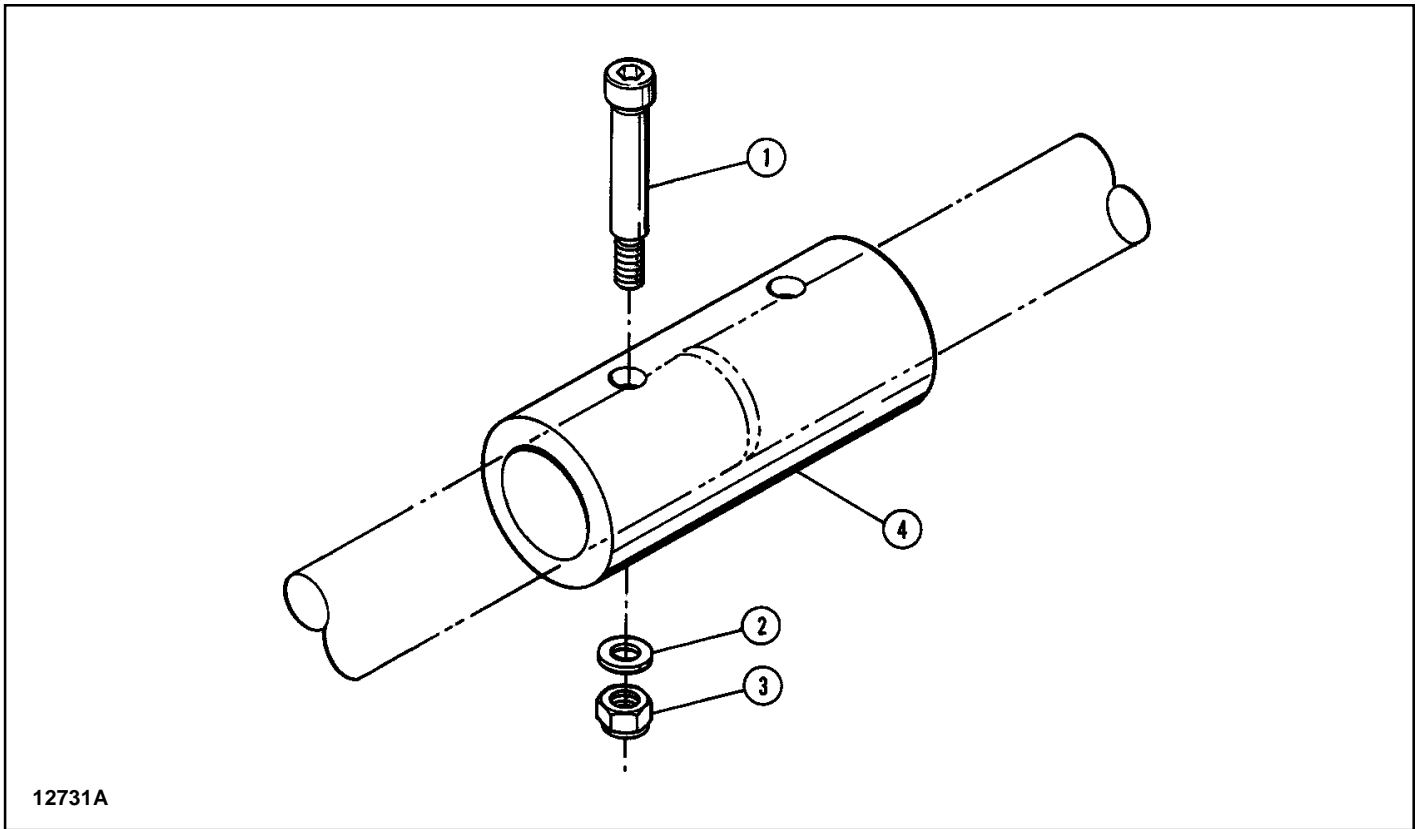
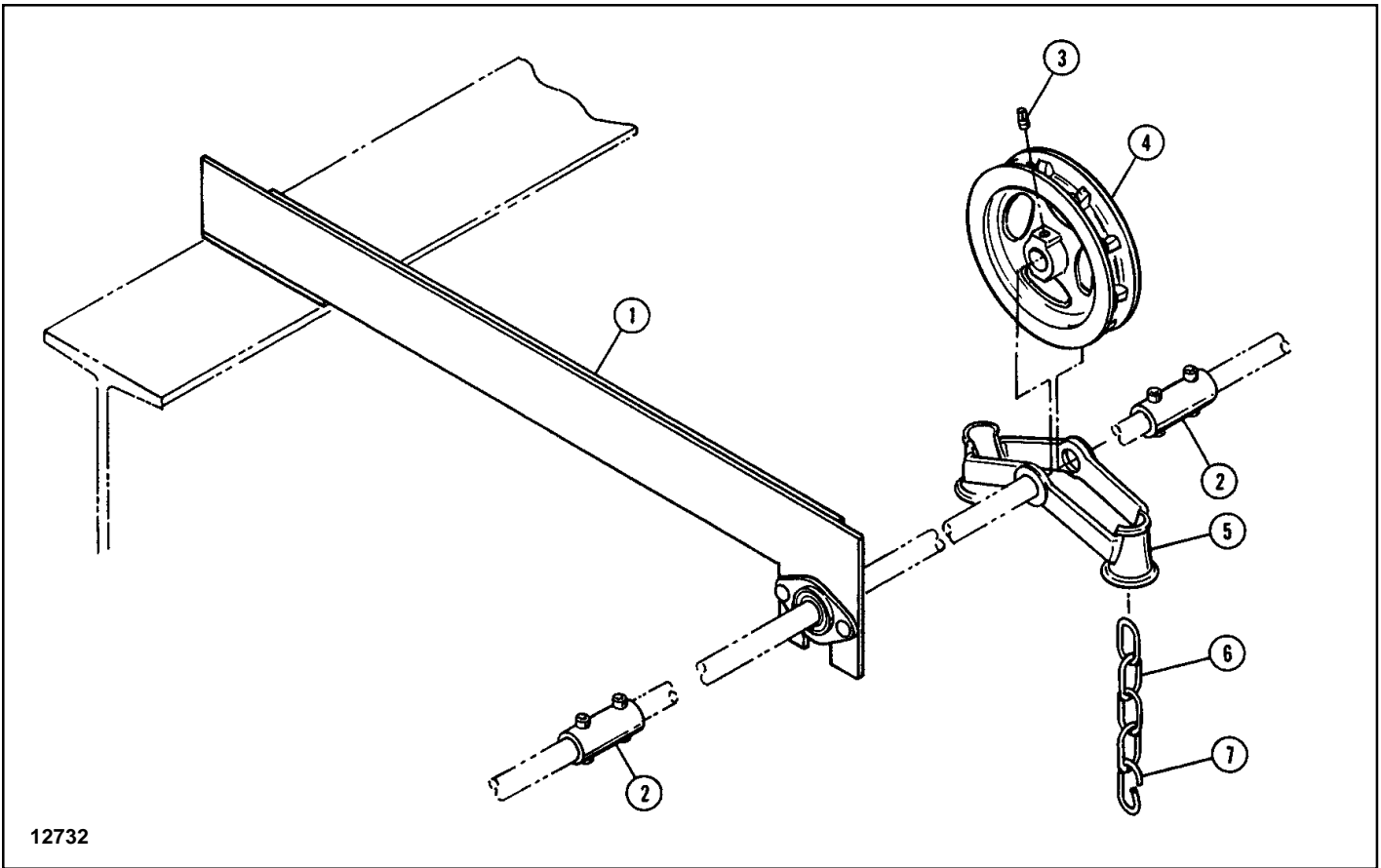

Figure 10. Coupling. Catalog Number 905374.

Ref. No.	Part Number	Description	Qty. Req'd
1	BTK-1001	Socket Head Shoulder Screw	2
2	BTK-1002	Plain Washer (Type W 1/4 Pltd.)	2
3	BTK-1003	Thin Hex Self-Locking Nut (1/4 - 20 Pltd.)	2
4	BTK-1004	Coupling	1

NOTES



12732

Figure 11. Hand Chain Drive. Catalog Numbers 905371 and 8282.

Ref. No.	Part Number	Description	Qty. Req'd
1		Catalog Number 905371 Consists of Ref. Nos. 1 thru 5:	
		Catalog Number 905373	1
2		Catalog Number 905374	2
3	BTK-1101	Square Head Set Screw, Cup Point (3/8 - 16 x 1 Pltd.)	1
4	BTK-1102	Hand Chain Wheel	1
5	BTK-1103	Chain Wheel Guide	1
		Catalog Number 8282 Consists of Ref. Nos. 6 and 7:	
6	BTK-1104	Hand Chain	36 ft.
7	BTK-1105	Connecting Link	1

NOTES

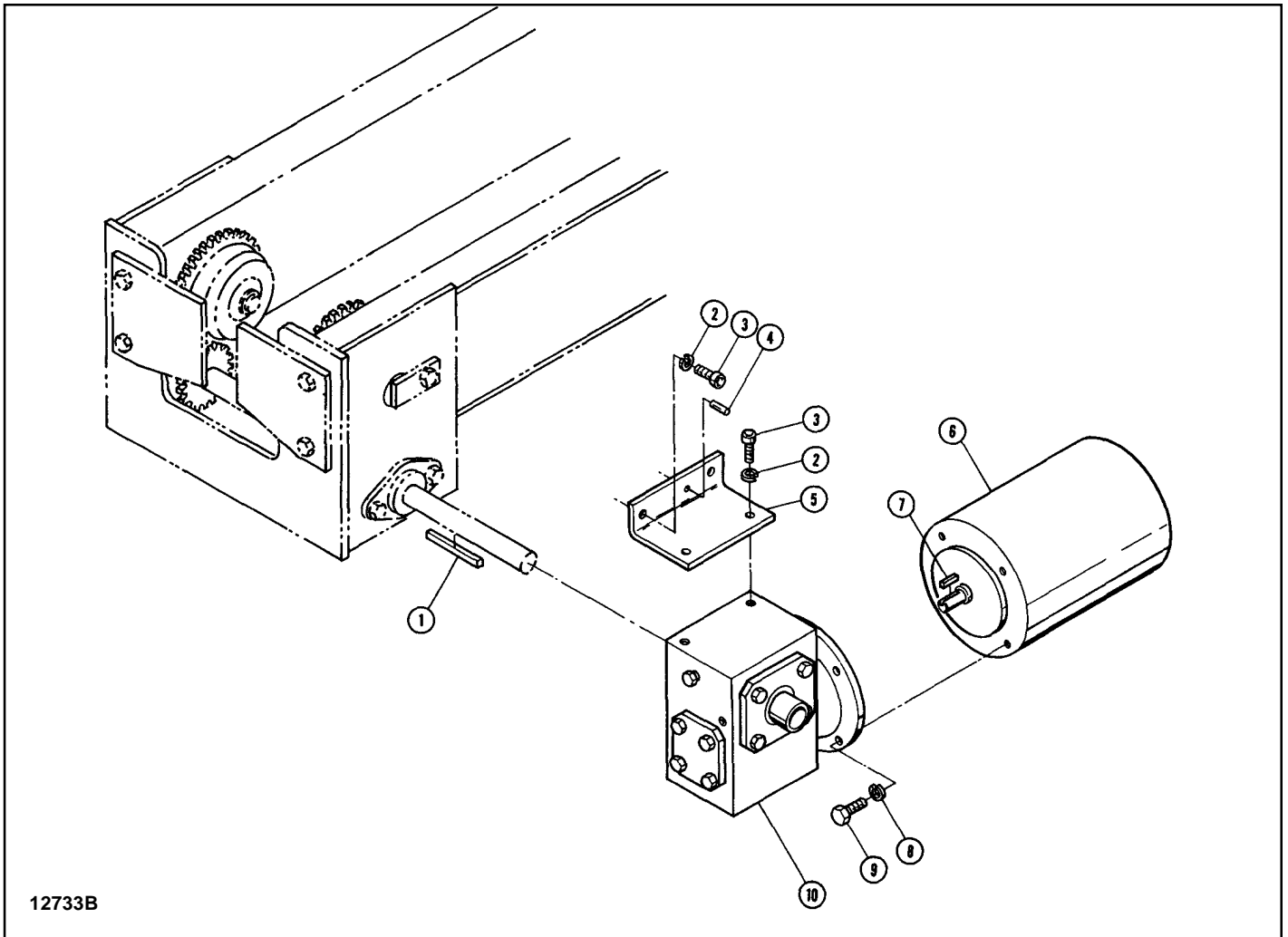

12733B

Figure 12. Gear Reducer. Catalog Numbers 905376 thru 905378) and motor (Catalog Numbers 905363, 905381, 905382 and 905394 thru 905396).

Ref. No.	Part Number	Description	Qty. Req'd
1	BTK-1201	Key	1
2	BTK-1202	Spring Lock Washer (5/16)	4
3	BTK-1203	Hex Socket Head Self-Locking Cap Screw (5/16-18 x 1)	4
4	BTK-1204	Grooved Pin (Type A 5/16 x 5/8 Pltd.)	1
5	BTK-1205	Support Plate	1
6		Motor	
		Single Speed	1
	BTK-1241	115/230V - 1 Phase - 60 Hz	
	BTK-1238	200-230/460V - 3 Phase - 60 Hz	
	BTK-1239	575V - 3 Phase - 60 Hz	
		Two Speed	
	BTK-1242	208/230V - 3 Phase - 60 Hz	
	BTK-1243	460V - 3 Phase - 60 Hz	
	BTK-1244	575V - 3 Phase - 60 Hz	
7	BTK-1237	Key	1
8	BTK-1240	Spring Lock Washer (3/8)	4
9	BTK-1245	Hex Head Bolt (3/8-16 x 1)	4
10		Gear Reducer	1
	BTK-1207	10:1 Gear Ratio	
	BTK-1208	15:1 Gear Ratio	
	BTK-1209	20:1 Gear Ratio	

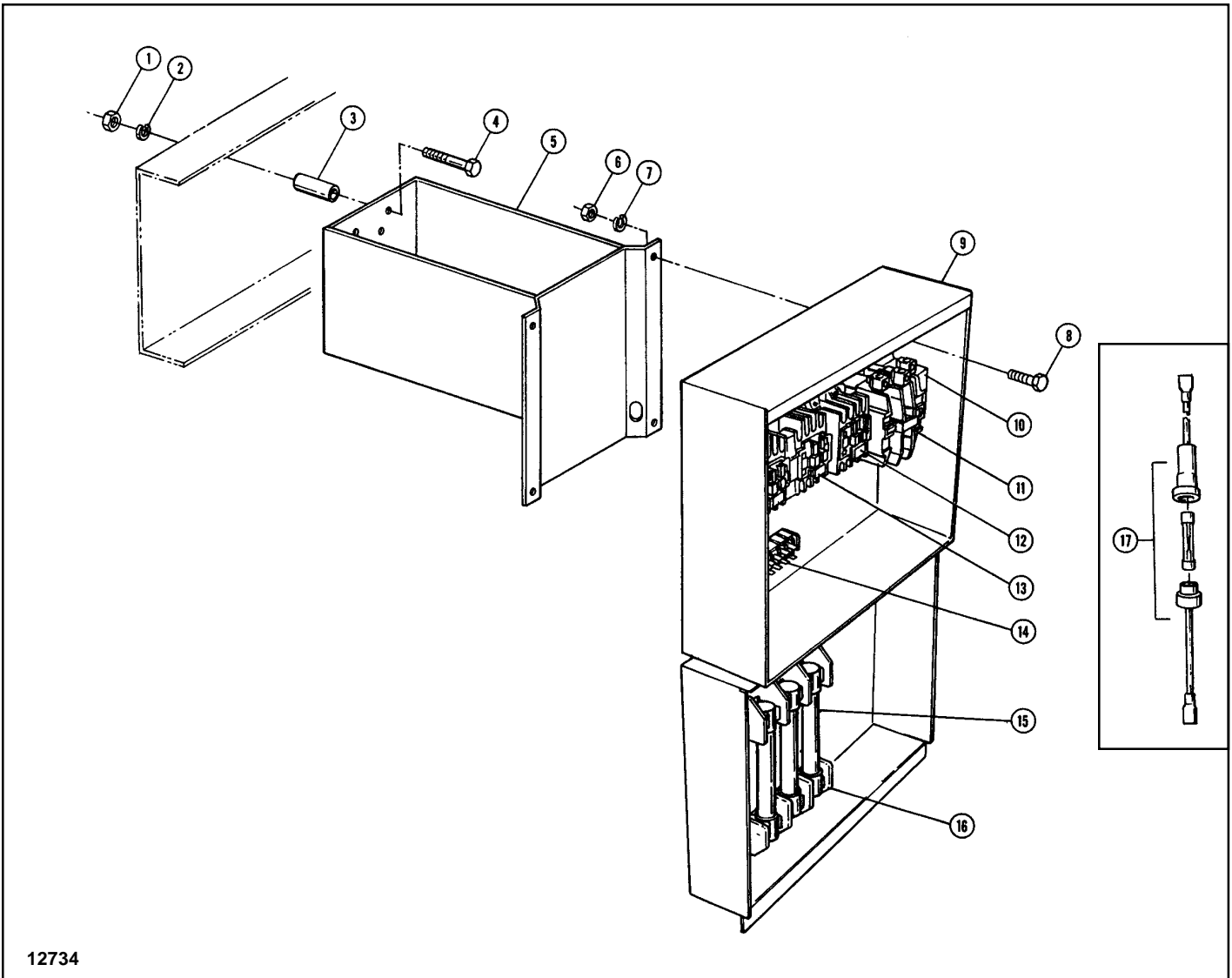

12734

Figure 13. Electrical Enclosure and Mounting. Catalog Numbers 905385 thru 905387.

Ref. No.	Part Number	Description	Qty. Req'd
1	BTK-1301	Hex Nut (5/16-18)	4
2	BTK-1302	Spring Lock Washer (5/16)	4
3	BTK-1303	Spacer	4
4	BTK-1304	Hex Head Bolt (5/16-18 x 1-3/4)	4
5	BTK-1305	Enclosure Mounting Bracket	1
6	BTK-1306	Hex Nut (1/4-20)	4
7	BTK-1307	Spring Lock Washer (1/4)	4
8	BTK-1308	Cross Recess Round Head Machine Screw (Type 11 1/4-20 x 3/4)	4
9	BTK-1309	Electrical Enclosure	1
10		Transformer	1
	BTK-1310	208/24V or 230/24V	
	BTK-1311	460/24V	
	BTK-1312	575/24V	
	BTK-1313	208/115V or 230/115V	
	BTK-1314	460/115V	
	BTK-1315	575/115V	
11		Mainline Contactor	1
	BTK-1316	24V Control	
	BTK-1317	115V Control	

Figure 13. Electrical Enclosure and Mounting (Continued).

Ref. No.	Part Number	Description	Qty. Req'd
12	BTK-1318 BTK-1319	Accelerating Contactor (For 2 Speed Cranes Only) 24V Control 115V Control	1
13	BTK-1320 BTK-1321	Reversing Contactor 24V Control 115V Control	1
14	BTK-1322	Terminal Board	1
15	BTK-1323 BTK-1324	Fuses 3A, 250V 3A, 600V	3
16	BTK-1325 BTK-1326	Fuse Base 30A, 250V 30A, 600V	1
17	BTK-1327 BTK-1328	Fuse, Fuse Holder and Wire Assembly (Control Circuit) 3A, 24V 1/2A, 115V	1
	* BTK-1329 BTK-1330	Fuse Only (Control Circuit) 3A, 250V Rating 1/2A, 250V Rating	1

*Replacement fuses are standard automotive type and may be purchased locally.

NOTES

Recommended Spare Parts for Your Crane Kit

Certain parts of your crane will, in time, require replacement under normal wear conditions. It is suggested that the following parts be purchased for your crane as spares for future use.

- 1 Set of Wheels
- 1 Set of Wheel Bearings
- 1 Set of Fuses (If Required)

Note: When ordering parts always furnish Model Number of crane kit.

Parts for your crane are available from your authorized repair station.
For the location of your nearest repair station, write:

IN USA

Yale•Lift-Tech
P.O. Box 769
Muskegon, MI 49443-0769

Phone: **800 742-9269**
Fax: **800 742-9270**

Columbus McKinnon Corporation
140 John James Audubon Parkway
Amherst, NY 14228

Phone: **800 888-0985**
Fax: **716 689-5644**

Coffing Hoists
P.O. Box 779
Wadesboro, NC 28170

Phone: **800 477-5003**
Fax: **800 374-6853**

IN CANADA

Columbus McKinnon Limited
P.O. Box 1106
Cobourg, Ontario K9A 4W5

Phone: **800 263-1997**
Fax: **800 603-0011**

WARRANTY

WARRANTY AND LIMITATION OF REMEDY AND LIABILITY

A. Seller warrants that its products and parts, when shipped, and its work (including installation, construction and start-up), when performed, will meet applicable specifications, will be of good quality and will be free from defects in material and workmanship. All claims for defective products or parts under this warranty must be made in writing immediately upon discovery and in any event, within one (1) year from shipment of the applicable item unless Seller specifically assumes installation, construction or start-up responsibility. All claims for defective products or parts when Seller specifically assumes installation, construction or start-up responsibility and all claims for defective work must be made in writing immediately upon discovery and in any event, within one (1) year from completion of the applicable work by Seller, provided; however, all claims for defective products and parts made in writing no later than eighteen (18) months after shipment. Defective items must be held for Seller's inspection and returned to the original f.o.b. point upon request. THE 'FOREGOING IS EXPRESSLY IN LIEU OF ALL OTHER WARRANTIES WHATSOEVER, EXPRESS, IMPLIED AND STATUTORY, INCLUDING, WITHOUT LIMITATION, THE IMPLIED WARRANTIES OF MERCHANTABILITY AND FITNESS.

B. Upon Buyer's submission of a claim as provided above and its substantiation, Seller shall at its option either (i) repair or replace its product, part or work at either the original f.o.b. point of delivery or at Seller's authorized service station nearest Buyer or (ii) refund an equitable portion of the purchase price.

C. This warranty is contingent upon Buyer's proper maintenance and care of Seller's products, and does not extend to normal wear and tear. Seller reserves the right to void warranty in event of Buyer's use of inappropriate materials in the course of repair or maintenance, or if Seller's products have been dismantled prior to submission to Seller for warranty inspection.

D. The foregoing is Seller's only obligation and Buyer's exclusive remedy for breach of warranty and is Buyer's exclusive remedy hereunder by way of breach of contract, tort, strict liability or otherwise. In no event shall Buyer be entitled to or Seller liable for incidental or consequential damages. Any action for breach of this agreement must be commenced within one (1) year after the cause of action has accrued.

COLUMBUS MCKINNON CORPORATION