

JAN 1958

P564J

YALE

MIDGET KING

ELECTRIC HOIST

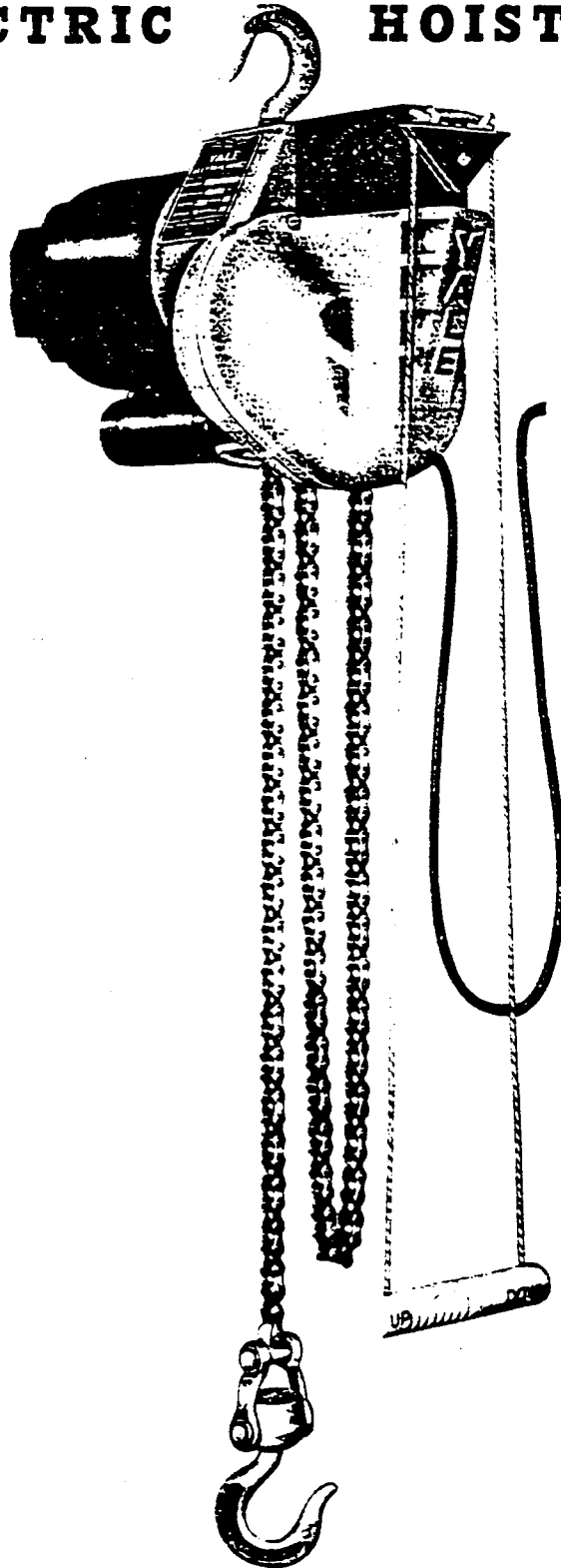

PARTS LIST

IMPORTANT

WHEN ORDERING
REPLACEMENT
PARTS GIVE COM-
PLETE MODEL
NUMBER OF HOIST.

IF MOTOR SPARES
ARE REQUIRED
GIVE MOTOR STYLE
OR MODEL NUMBER
WHICH IS STAMPED
ON MOTOR NAME
PLATE.

THE YALE & TOWNE MANUFACTURING COMPANY

YALE MATERIALS HANDLING DIVISION

PHILADELPHIA 15, PA., U. S. A.

YALE

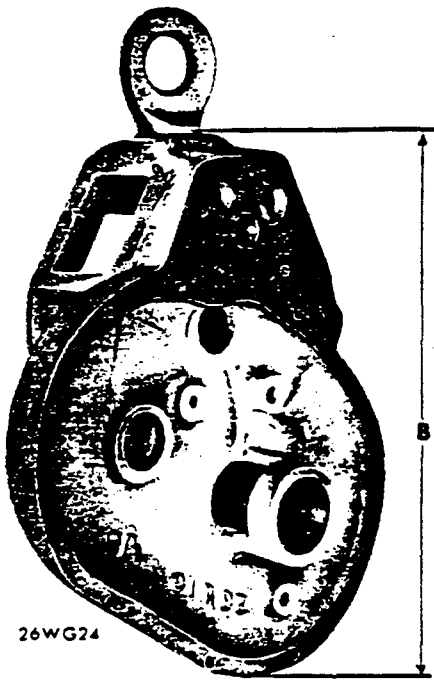

26WG24

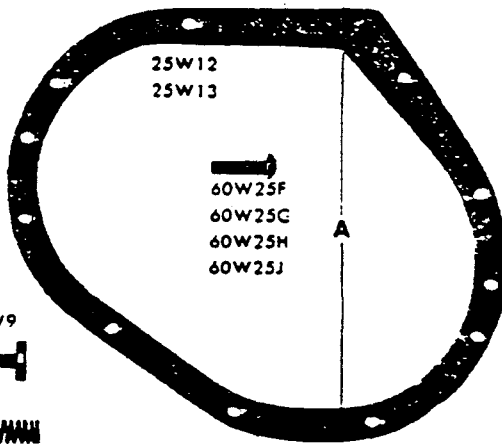

25W12
25W13

60W25F
60W25C
60W25H
60W25J



94WG54

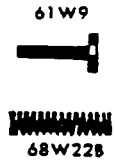

61W9
68W22B

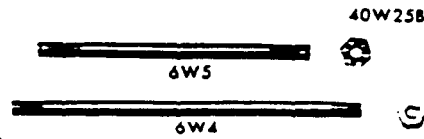

40W25B
6W5
6W4



31W93

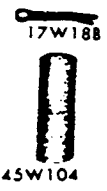

17W188
45W104

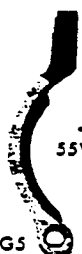

55W12A
14W7



69W8



45W66
45W71

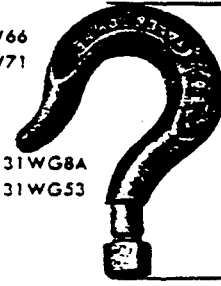

31WG8A
31WG53

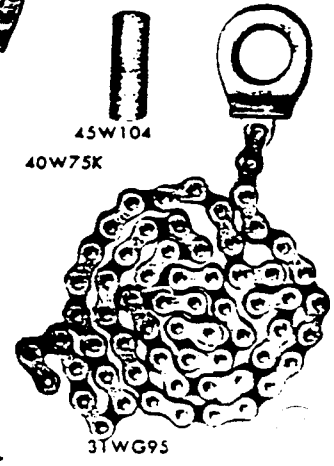

40W75K

31WG9S

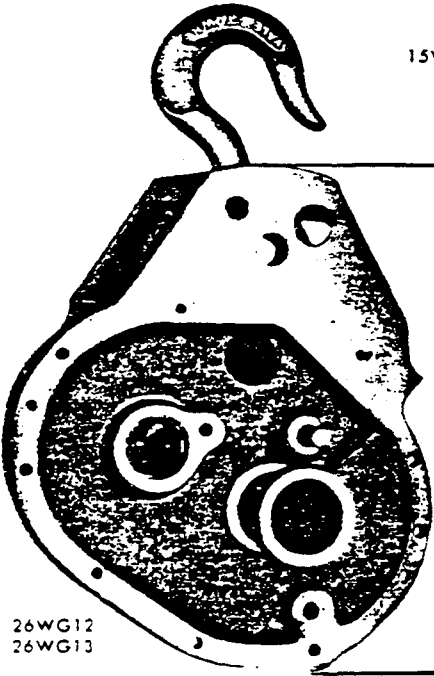

26WG12
26WG13



13W6

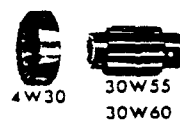

4W30
30W55
30W60

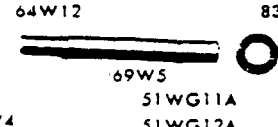

64W12
69W5
51WG11A
51WG12A

83W33

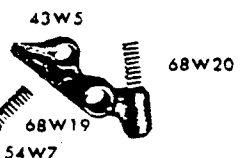

43W5
68W19
54W7
68W20



40W50C



12W4
88W15A

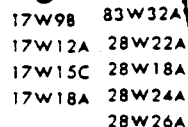

17W98
17W12A
17W15C
17W18A
83W32A
28W22A
28W18A
28W24A
28W26A

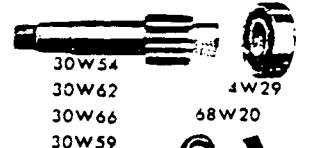

30W54
30W62
30W66
30W59
4W29
68W20



43W10

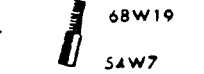

68W19
54W7

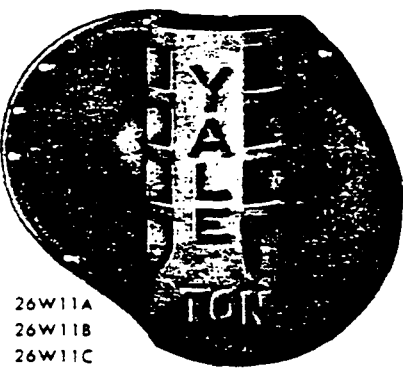

26W11A
26W11B
26W11C
26W16
26W16A



64W16
83W80

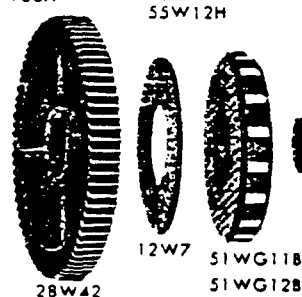

12W7
51WG11B
51WG12B

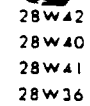

28W42
28W40
28W41
28W36

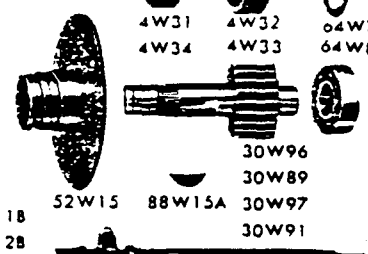

4W31
4W32
4W33
4W34
4W33
64W7
64W8
30W96
30W89
30W97
30W91

4W29

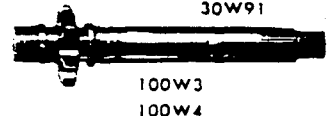

100W3
100W4



69W7

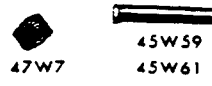

47W7
45W59
45W61



11W66
11W69

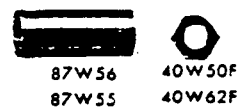

87W56
87W55
40W50F
40W62F

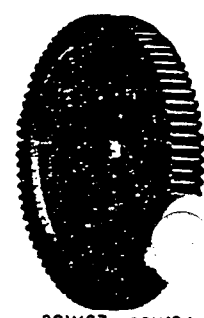

29W27
29W34
29W30
29W28

YALE

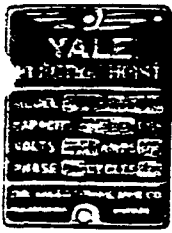

18W17

60W19C



18W22

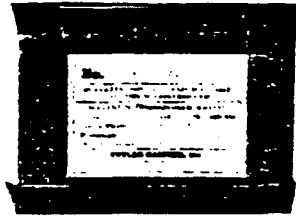

77W13



77W30



77W31

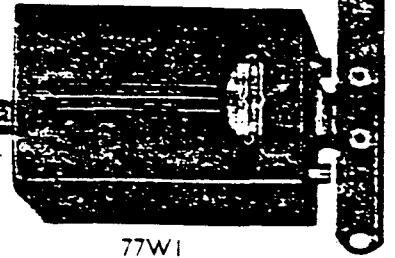

77W1
77W1A

60W19E

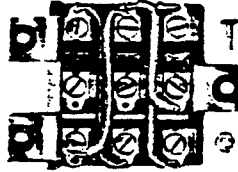

77WG12



77WG12A



77W8

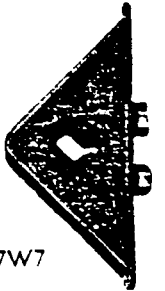

77W7

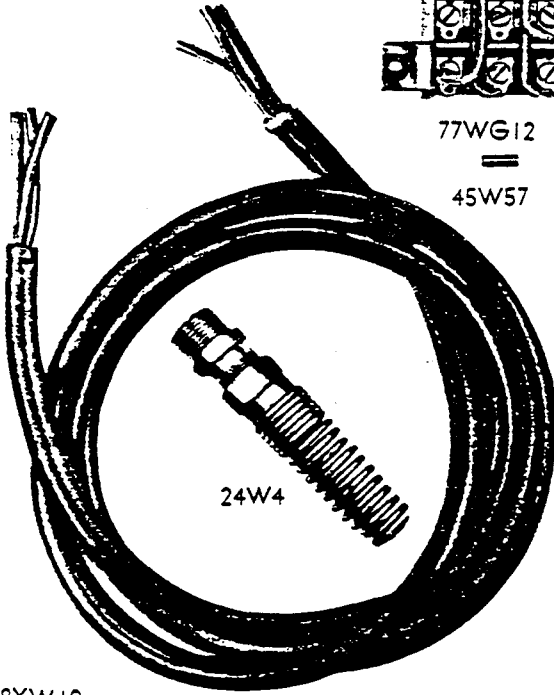

24W4



33W32

77W10

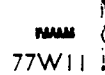

77W11

24W50

77W9

107W3
107W6



107W1
107W4

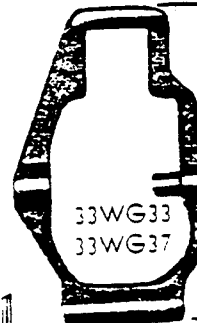

33WG33
33WG37

17W98
17W12A
17W15C
17W18A

107W2
107W5

107W21

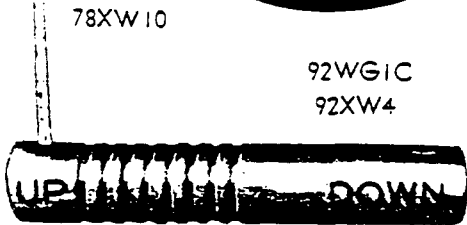

78XW10

78W11

92WG1C
92XW4



107W20

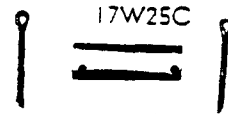

17W25C

45W103



100WG16



10WG90

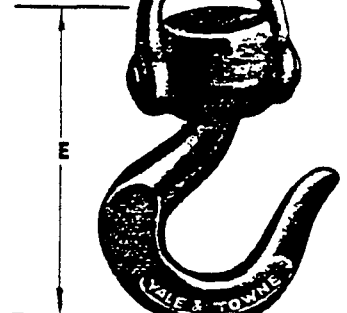

31WG26
31WG36

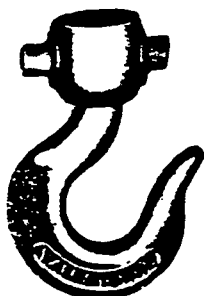

31WG5

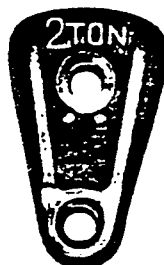

10W93



YALE

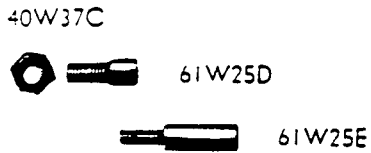
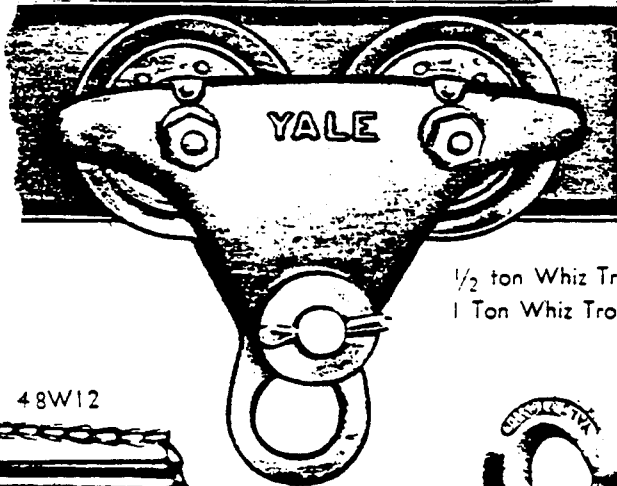
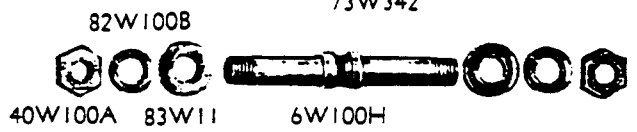
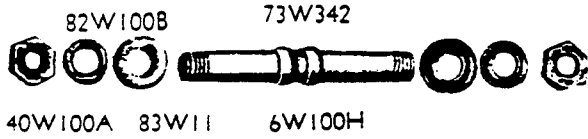
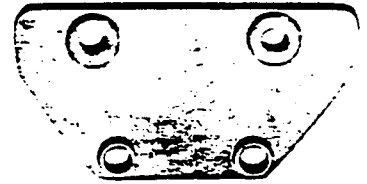
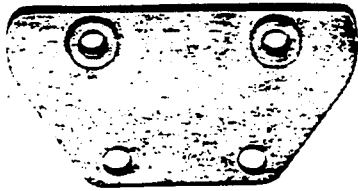
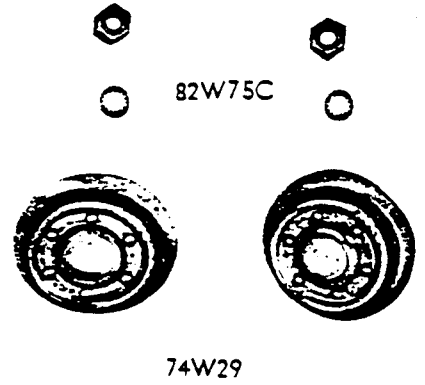
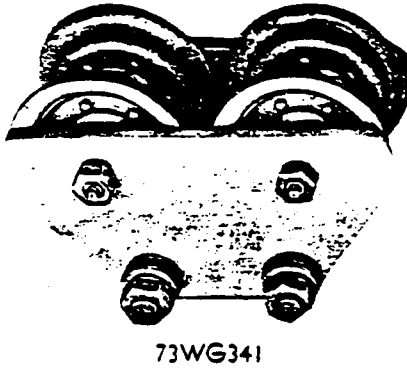
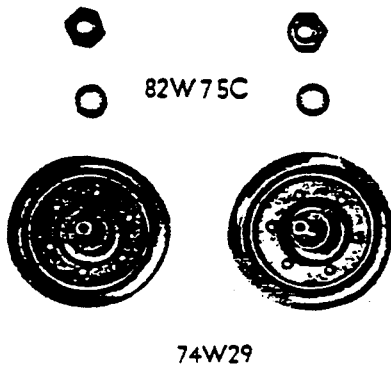

48W12

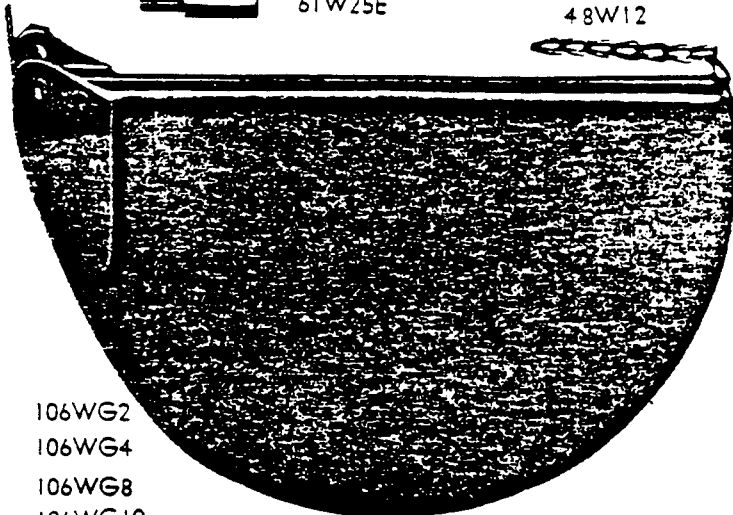

60W19D

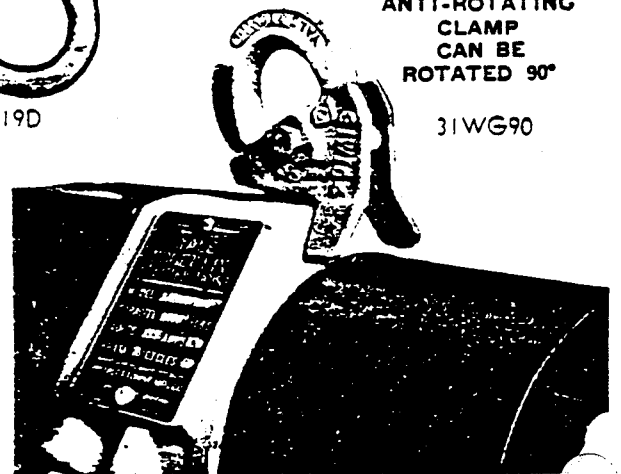

YALE

PARTS LIST

MIDGET KING ELECTRIC HOISTS

Part No.	Page No.	Quan- per Hoist	DESCRIPTION	PARTS USED ON	
				Capacity	Model
4W29	2	2	#202 Ball Bearing not Sealed	All	D, E & K
4W30	2	1	#6202-2RS Ball Bearing Double Sealed	All	D, E & K
4W31	2	2	#6203-2RS Ball Bearing Double Sealed	1/2 ton to 1/2 ton	D, E & K
4W32	2	1	#203 Ball Bearing not Sealed	1/2 ton to 1/2 ton	D, E & K
4W33	2	1	#204 Ball Bearing not Sealed	1 ton and 2 ton	D, E & K
4W34	2	2	#6204-2RS Ball Bearing Double Sealed	1 ton and 2 ton	D, E & K
6W4	2	1	Double End Stud 6 3/4" Long	All	D, E & K
6W5	2	1	Brake Spring Stud 4 1/4" Long	All	D, E & K
6W100H	6	2	Double End Stud	2 ton	D, E & K
10WG90	3	1	Roller Chain Bottom Block Assembly	2 ton	D, E & K
10W93	3	2	Roller Chain Block Half	2 ton	D, E & K
11W66	2	1	Chain Stripper (1 1/4" Wide)	1/2 ton to 1/2 ton	D, E & K
11W69	2	1	Chain Stripper (1 1/2" Wide)	1 and 2 ton	D, E & K
12W4	2	2	Raybestos Brake Disc	All	D
12W7	2	2	Raybestos Brake Disc	All	E
13W6	2	1	Brake Drum	All	D, E & K
14W7	2	2	Brake Lining only	All	D, E & K
15WG5	2	2	Brake Shoe with Lining	All	D, E & K
17W9B	2	2	Cotter 1/4" x 3/4"	All	D, E & K
17W12A	2	2	Cotter 1/4" x 3/4"	All	D, E & K
17W15C	2	2	Cotter 1/4" x 3/4"	All	D, E & K
17W18A	2	1	Cotter 1/4" x 1 1/2"	All	D, E & K
17W18B	2	4	Cotter Pin 1/4" x 1 3/4"	2 ton	D, E & K
17W25C	3	2	Cotter Pin 1/4" x 2"	2 ton	D, E & K
18W17	3	1	Name Plate and Brake Cover	All	D, E & K
18W22	3	1	Instruction Plate and Brake Cover	All	D, E & K
20W45	2	2	Strain Reliever	All	D, E & K
24W4	3	1	Strain Reliever for Wire	All	D, E & K
24W50	3	6	Wire Terminal	All	D, E & K
25W12	2	1	Housing Gasket (Dim. "A" 7 1/4")	1/2 ton to 1/2 ton	D, E & K
25W13	2	1	Housing Gasket (Dim. "A" 9 1/4")	1 and 2 ton	D, E & K
26W11A	2	1	Gear Case Cover	1/2 ton	D, E & K
26W11B	2	1	Gear Case Cover	1/2 ton	D, E & K
26W11C	2	1	Gear Case Cover	1/2 ton	D, E & K
26WG12	2	1	Gear Housing and Main Frame with studs, top hook and wire eye (Dim. "B" 10 1/4")	1/2 ton to 1/2 ton	D, E & K
26WG13	2	1	Gear Housing and Main Frame with studs, top hook and wire eye (Dim. "B" 12 1/4")	1 ton	D, E & K
26W16	2	1	Gear Case Cover	1 ton	D, E & K
26W16A	2	1	Gear Case Cover	2 ton	D, E & K
26WG24	2	1	Gear Housing and Main Frame with studs, top clevis and wire eye (Dim. "B" 12 1/4")	2 ton	D, E & K
28W18A	2	1	High Speed Gear, 74 Teeth	1/2 ton to 1/2 ton—34 and 17 F.P.M.	D
28W22A	2	1	High Speed Gear, 100 Teeth	1 ton—9 F.P.M.	D
28W24A	2	1	High Speed Gear, 78 Teeth	1/2 ton—11 and 24 F.P.M.	D
28W26A	2	1	High Speed Gear, 96 Teeth	1 ton—13 and 17 F.P.M. and 2 ton	D
28WG34	1	1	Replacement Load Brake (not shown)	1/2, 1/4, 1/2 ton	D
28WG35	1	1	Replacement Load Brake (not shown)	1 and 2 ton	D
28W36	2	1	High Speed Gear, 96 Teeth	1 ton—13 and 17 F.P.M. and 2 ton	E
28W40	2	1	High Speed Gear, 74 Teeth	1/2 ton to 1/2 ton—34 and 17 F.P.M.	E
28W41	2	1	High Speed Gear, 78 Teeth	1/2 ton—11 and 24 F.P.M.	E
28W42	2	1	High Speed Gear, 100 Teeth	1 ton—9 F.P.M.	E
29W27	2	1	Slow Speed Gear, 81 Teeth	1/2 ton—17 F.P.M., 1/2 ton—17 and 11 F.P.M.	D, E & K
29W28	2	1	Slow Speed Gear, 92 Teeth	1 ton—17 F.P.M., 2 ton—8 1/2 F.P.M.	D, E & K
29W30	2	1	Slow Speed Gear, 72 Teeth	1/2 ton to 1/2 ton—34 F.P.M., 1/2 ton—24 F.P.M.	D, E & K
29W34	2	1	Slow Speed Gear, 95 Teeth	1 ton—9 and 13 F.P.M., 2 ton—6 1/2 F.P.M.	D, E & K
30W54	2	1	Intermediate Pinion, 12 Teeth	1/2 ton, 1/2 ton—17 F.P.M., 1/2 ton—11 F.P.M.	D
30W55	2	1	Motor Pinion, 16 Teeth	1/2 ton to 1/2 ton—34 and 17 F.P.M., 1 ton—13 and 17 F.P.M., 2 ton	D, E & K
30W59	2	1	Intermediate Pinion, 15 Teeth	1 ton—17 F.P.M., 2 ton—8 1/2 F.P.M.	D, E & K
30W60	2	1	Motor Pinion, 12 Teeth	1/2 ton—11 and 24 F.P.M., 1 ton—9 F.P.M.	D, E & K
30W62	2	1	Intermediate Pinion, 21 Teeth	1/2 ton to 1/2 ton—34 F.P.M., 1/2 ton—24 F.P.M.	D
30W66	2	1	Intermediate Pinion, 12 Teeth	1 ton—9 and 13 F.P.M., 2 ton—6 1/2 F.P.M.	D
30W89	2	1	Intermediate Pinion, 21 Teeth	1/2 ton to 1/2 ton—34 F.P.M., 1/2 ton—24 F.P.M.	E
30W91	2	1	Intermediate Pinion, 15 Teeth	1 ton—17 F.P.M., 2 ton—8 1/2 F.P.M.	E
30W96	2	1	Intermediate Pinion, 12 Teeth	1/2 ton, 1/2 ton—17 F.P.M., 1/2 ton—11 F.P.M.	E
30W97	2	1	Intermediate Pinion, 12 Teeth	1 ton—9 and 13 F.P.M., 2 ton—6 1/2 F.P.M.	E
31WG5	3	1	Bottom Block Hook Assembly	2 ton	D, E & K
31WG8A	2	1	Upper Hook with Nut (Dim. "C" 5 1/4")	1 ton	D, E & K

YALE

PARTS LIST

MIDGET KING ELECTRIC HOISTS

Part No.	Page No.	Quan. per Hoist	DESCRIPTION	PARTS USED ON	
				Capacity	Model
31WG26	3	1	Lower Hook Assembly complete with roller chain Connecting Link (Dim. "E" 5 $\frac{1}{4}$ ")	$\frac{1}{2}$ ton to $\frac{1}{2}$ ton	D, E & K
31WG26A	3	1	Special Lower Hook Assembly	$\frac{1}{2}$ ton to $\frac{1}{2}$ ton	D, E & K
31WG36	3	1	Lower Hook Assembly complete with roller chain Connecting Link (Dim. "E" 6 $\frac{1}{4}$ ")	1 ton	D, E & K
31WG53	2	1	Upper Hook with Nut (Dim. "C" 4 $\frac{1}{4}$ ")	$\frac{1}{2}$ ton to $\frac{1}{2}$ ton	D, E & K
31WG63	2	1	Lower Swivel Hook complete with roller chain Connecting Link and Safety Snap Hook	$\frac{1}{2}$ ton to $\frac{1}{2}$ ton	D, E & K
31WG88	6	1	Special Lower Hook Assembly	1 ton	D, E & K
31WG90	6	1	Anti Rotating Clamp Assembly (can be rotated 90°) Two Clamps and Bolt	$\frac{1}{2}$ ton to 1 ton	D, E & K
31W93	2	1	Top Clevis	2 ton	D, E & K
31W94	2	1	Clevis	2 ton	D, E & K
31WG95	2	1	Clevis Assembly complete with 23 feet 107W4 Roller Chain and Connecting Links	2 ton	D, E & K
33W32	3	1	Controller Lever	All	D, E & K
33WG33	3	1	Limit Paddle Lever with 69W6 Stud (Dim. "F" 5 $\frac{1}{4}$ ")	$\frac{1}{2}$ ton to $\frac{1}{2}$ ton	D, E & K
33WG37	3	1	Limit Paddle Lever with 69W6 Stud (Dim. "F" 5 $\frac{1}{4}$ ")	1 ton to 2 ton	D, E & K
36WG2	1	1	Yale Gear Oil, 1 Pint	All	D, E & K
36WG2	1	1	Yale Gear Oil, per Gallon	All	D, E & K
40W25B	2	2	Hex. Nut $\frac{1}{4}$ "—20 (Slotted)	All	D, E & K
40W25C	2	4	Hex. Nut $\frac{1}{4}$ "—20	All	D, E & K
40W37C	6	1	Hex. Nut $\frac{3}{8}$ "—16	All	D, E & K
40W50B	4	4	Hex. Nut $\frac{1}{2}$ " for Strain Reliever		
40W50C	2	1	Hex. Nut $\frac{1}{2}$ "—20 (Slotted)	All	D, E & K
40W50F	2	1	Hex. Nut $\frac{1}{2}$ "—20	All	D, E & K
40W62F	2	1	Hex. Nut $\frac{3}{8}$ "—18 (Slotted)	1 ton and 2 ton	D, E & K
40W75K	2	1	Hex. Nut $\frac{3}{4}$ "—10	2 ton	D, E & K
40W100A	6	4	Hex. Nut 1"—8	2 ton	D, E & K
40W112D	2	1	Hook Nut	2 ton	D, E & K
43W5	2	1	Ratchet Pawl	All	D
43W10	2	1	Ratchet Pawl	All	E
45W57	3	1	Control Rod Pin—Upper	All	D, E & K
45W58	3	1	Control Rod Pin—Lower	All	D, E & K
45W59	2	1	Headed Pin for Stripper (1 $\frac{1}{4}$ " Long)	$\frac{1}{2}$ ton to $\frac{1}{2}$ ton—34, 17 and 24 F.P.M.	D, E & K
45W61	2	1	Headed Pin for Stripper (2 $\frac{1}{4}$ " Long)	1 ton and 2 ton	D, E & K
45W66	2	1	Pin for 16 Tooth Motor Pinion (1" Long)	$\frac{1}{2}$ ton to $\frac{1}{2}$ ton—34 and 17 F.P.M., 1 ton—13 and 17 F.P.M. and 2 ton—9 F.P.M.	D, E & K
45W71	2	1	Pin for 12 Tooth Motor Pinion ($\frac{1}{2}$ " Long)	$\frac{1}{2}$ ton—11 and 24 F.P.M. and 1 ton—9 F.P.M.	D, E & K
45W103	3	1	Pin for Bottom Block	2 ton	D, E & K
45W104	2	2	Pin for Clevis	2 ton	D, E & K
47W7	2	1	Pipe Plug— $\frac{3}{8}$ " Headless	All	D, E & K
48W4	5	5	"S" Hook		
48W12	6	1	Chain for Chain Container	All	D, E & K
51WG11A	2	1	Ratchet Disc, 16 Teeth with Brake Discs	$\frac{1}{2}$ ton to $\frac{1}{2}$ ton and 2 ton—6 $\frac{1}{2}$ F.P.M.	D
51WG11B	2	1	Ratchet Disc, 18 Teeth with Brake Discs	$\frac{1}{2}$ ton to $\frac{1}{2}$ ton and 2 ton—6 $\frac{1}{2}$ F.P.M.	E
51WG12A	2	1	Ratchet Disc, 20 Teeth with Brake Discs	1 ton to 2 ton	D
51WG12B	2	1	Ratchet Disc, 20 Teeth with Brake Discs	1 ton to 2 ton	E
52W10	2	1	Brake Disc Hub	All	D
52W15	2	1	Brake Disc Hub	All	E
54W7	2	1	Pawl Spring Retainer Cup	All	D, E & K
55W12A	2	6	Tubular Brake Lining Rivet $\frac{1}{8}$ " x $\frac{3}{8}$ " Brass	All	D, E & K
55W12H	2	3	Tubular Brake Lining Rivet $\frac{1}{8}$ " x $\frac{3}{8}$ " Brass	All	E
55W14A	2	3	Tubular Brake Disc Rivet $\frac{1}{8}$ " x $\frac{1}{4}$ " Brass	All	D
56W12	2	1	per foot, Galvanized Iron Wire for Electric Cord Suspension		
60W19C	3	2	Round Head Screw #10—24 x $\frac{1}{4}$ "	All	D, E & K
60W19D	6	1	Round Head Screw #10—24 x $\frac{1}{2}$ "	All	D, E & K
60W19E	3	1	Round Head Screw #10—24 x $\frac{3}{4}$ "	All	D, E & K
60W25F	2	5	Round Head Screw $\frac{1}{4}$ "—20 x $\frac{1}{4}$ "	All	D, E & K
60W25G	2	3	Round Head Screw $\frac{1}{4}$ "—20 x $1\frac{1}{2}$ "	All	D, E & K
60W25H	2	4	Round Head Screw $\frac{1}{4}$ "—20 x $\frac{3}{8}$ "	All	D, E & K
60W25J	2	1	Round Head Screw $\frac{1}{4}$ "—20 x 1"	All	D, E & K
61W9	2	2	Brake Adjusting Screw	All	D, E & K
61W25D	6	1	Special Screw—Short (for Chain Container)	All	D, E & K
61W25E	6	1	Special Screw—Long (for Chain Container)	All	D, E & K
64W7	2	1	Snap Ring for Ball Bearing	1 ton and 2 ton	D, E & K
64W8	2	1	Snap Ring for Ball Bearing	$\frac{1}{2}$ ton to $\frac{1}{2}$ ton	D, E & K
64W12	2	1	Snap Ring .41" inside diameter	All	D, E & K
64W16	2	2	Retainer Ring	All	E
68W19	2	1	Pawl Drag Spring	All	D, E & K
68W20	2	1	Pawl Return Spring	All	D, E & K
68W22B	2	2	Brake Spring	All	D, E & K
69W5	2	1	Brake and Pawl Stud	All	D, E & K
69W7	2	1	Inner Paddle Stud	All	D, E & K
69W8	2	1	Brake Stud	All	D, E & K

YALE

PARTS LIST

MIDGET KING ELECTRIC HOISTS

Part No.	Page No.	Quan. per Hoist	DESCRIPTION	PARTS USED ON	
				Capacity	Model
73WG341	6	1	Plain Trolley Assembly complete.	2 ton	D, E & K
73W342	6	2	Trolley Side Plate.	2 ton	D, E & K
74W29	6	4	Trolley Wheel Assembly with Axle, Nut and Lockwasher.	2 ton	D, E & K
77W1	3	1	Reversing Switch with Lever—For Single Phase A.C. Motor.	All	D, E & K
77W1A	3	1	Reversing Switch with Lever—For D.C. Motor or 2 Phase or 3 Phase A.C. Motor.	All	D, E & K
77W7	3	1	Rope Lever.	All	D, E & K
77W8	3	1	Stop Lever.	All	D, E & K
77W9	3	1	Star Wheel Roller and Lever with Spring.	All	D, E & K
77W10	3	6	Moving Contact Finger.	All	D, E & K
77W11	3	6	Contact Spring.	All	D, E & K
77WG12	3	1	Stationary Contact Assembly complete with Screws and Springs for Single Phase A.C. Motor.	All	D, E & K
77WG12A	3	1	Stationary Contact Assembly for D.C. Motor or 2 Phase or 3 Phase A.C. Motor.	All	D, E & K
77W13	3	1	Cover.	All	D, E & K
77W30	3	4	Contact Arm, L. H.	All	D, E & K
77W31	3	3	Contact Arm, R. H.	All	D, E & K
78XW10	3	1	Braided Cotton Line— $\frac{1}{4}$ " Diameter, 15 ft. Long.	All	D, E & K
78W11	3	1	Control Handle Grip.	All	D, E & K
82W75C			Lockwasher.	2 ton	D, E & K
82W100B	6	4	Lockwasher 1"	2 ton	D, E & K
83W11	6	20	Adjusting Washer.	2 ton	D, E & K
83W32A	2	1	Centering Washer.	All	D
83W33	2	1	Washer for Pawl $\frac{1}{4}$ " O.D.	All	D, E & K
83W80	2	1	Stop Washer.	All	E
83W82		2	Flat Washer.	All	D, E & K
87W55	2	1	Spacer Tube ($2\frac{1}{4}$ " Long).	$\frac{1}{2}$ ton to $\frac{1}{2}$ ton.	D, E & K
87W56	2	1	Spacer Tube ($1\frac{1}{4}$ " Long).	1 ton to 2 ton.	D, E & K
88W15A		2	Woodruff Key #506.	All	D, E & K
89W11		2	Dowel Pin.	All	D, E & K
90W4	3		Crosshead.	$\frac{1}{2}$ ton to $\frac{1}{2}$ ton.	D, E & K
90W5	2		Crosshead.	1 ton.	D, E & K
92WG1C			Portable Rubber Cable—3 Wires #14—16 ft. Long	All	D, E & K
92XW1			per foot, Rubber Cable—3 wires #14	All	D, E & K
92XW4			per foot, Rubber Cable—4 wires #14	All	D, E & K
94W53			Hook Adapter.	2 ton	D, E & K
94WG54		1	Hook and Adapter Assembly.	2 ton	D, E & K
99W4			Roller Chain $\frac{3}{4}$ " Bushing.	2 ton	D, E & K
99W17			Oilite Bushing.	2 ton	D, E & K
100W3	2	1	Load Sprocket $\frac{3}{8}$ " Pitch.	$\frac{1}{2}$ ton to $\frac{1}{2}$ ton.	D, E & K
100W4	2	1	Load Sprocket $\frac{3}{4}$ " Pitch.	1 ton to 2 ton.	D, E & K
100WG16		1	Sprocket Assembly with Bushing, 12 Teeth.	2 ton	D, E & K
104W1	3	1	Controller Connecting Link ($7\frac{1}{4}$ " Long).	$\frac{1}{2}$ ton to $\frac{1}{2}$ ton.	D, E & K
104W3	3	1	Controller Connecting Link ($9\frac{1}{2}$ " Long).	1 ton and 2 ton.	D, E & K
106WG2	6	1	Chain Container Assembly including special screws and sash chain (maximum capacity—15 foot lift).	$\frac{1}{2}$ ton to $\frac{1}{2}$ ton.	D, E & K
106WG4	6	1	Chain Container Assembly including special screws and sash chain (maximum capacity—15 foot lift).	1 ton.	D, E & K
106WG8	6	1	Chain Container Assembly including special screws and sash chain (maximum capacity—25 foot lift).	$\frac{1}{2}$ ton to $\frac{1}{2}$ ton.	D, E & K
106WG10	6	1	Chain Container Assembly including special screws and sash chain (maximum capacity—25 foot lift for 1 ton, 10 foot lift for 2 ton).	1 ton and 2 ton.	D, E & K
107W1	3	1	Roller Chain— $\frac{3}{8}$ " pitch—11 ft. long with 2 connecting links.	$\frac{1}{2}$ ton to $\frac{1}{2}$ ton.	D, E & K
			per foot, Extra Chain for Part 107W1.	$\frac{1}{2}$ ton to $\frac{1}{2}$ ton.	D, E & K
107W2	3	1	Roller Chain Riveted Connecting Link for splicing chain.	$\frac{1}{2}$ ton to $\frac{1}{2}$ ton.	D, E & K
107W3	3	1	Roller Chain Spring Connecting Link for attaching Slack Chain to Housing.	$\frac{1}{2}$ ton to $\frac{1}{2}$ ton.	D, E & K
107W4	3	1	Roller Chain $\frac{3}{4}$ " Pitch—11 ft. long with 2 Connecting Links for 1 ton.	1 ton.	D, E & K
107W4	3	1	Roller Chain $\frac{3}{4}$ " Pitch—23 ft. long with 2 Connecting Links.	2 ton.	D, E & K
			per foot, Extra Chain for Part 107W4.	1 and 2 ton.	D, E & K
107W5	3	1	Roller Chain Riveted Connecting Link for splicing chain.	1 ton and 2 ton.	D, E & K
107W6	3	1	Roller Chain Spring Connecting Link for attaching Slack Chain to Housing.	1 ton and 2 ton.	D, E & K
			Steel Ball Bearing Trolley for Hook Type Hoist.	$\frac{1}{2}$ to $\frac{1}{2}$ ton.	D, E & K
			Steel Ball Bearing Trolley for Hook Type Hoist.	1 ton.	D, E & K
107W20	3	1	Riveted Connection for attaching chain to load hook.	$\frac{1}{2}$ ton to $\frac{1}{2}$ ton.	E
107W21	3	1	Riveted connecting link for attaching chain to load hook on 1 ton and on chain to clevis on 2 ton.	1 ton and 2 ton.	E

WESTINGHOUSE SINGLE-PHASE MOTORS

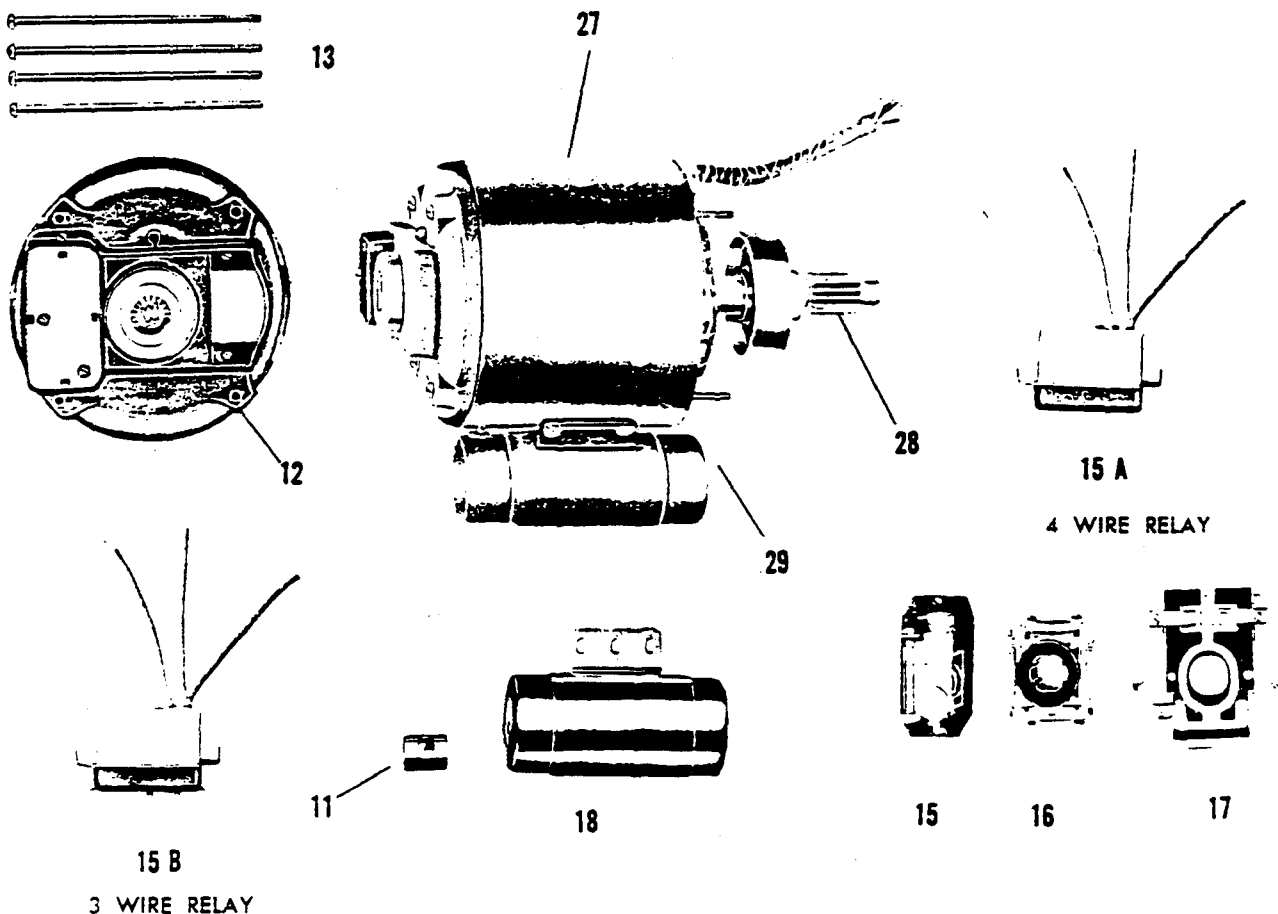

Part Name	Fig. No.	Quan.
Bearing—Plain Bushing	11	1
End Bell—with Bearing	12	1
Long Screw	13	4
* Reversing Relay—Complete (See Table on opposite page).....	15	1
* Reversing Relay—Complete (See Table on opposite page).....	15A	1
* Reversing Relay—Complete (See Table on opposite page).....	15B	1
* Rotating Switch (See Table on opposite page)	16	1
* Stationary Switch (See Table on opposite page)	17	1
Capacitor with Mounting.....	18	1
Complete Motor with Brake Drum, Ball Bearing, and Pinion.....	29	1

Meter frame with wound primary (27) and rotor with shaft (28) cannot be supplied as spare parts.

* Above figures numbers refer to motor master spare parts list which is in dealer's possession.

WESTINGHOUSE SINGLE-PHASE MOTORS

IMPORTANT

If motor repair parts are required give all information listed on hoist and motor name plates.

To Disassemble

Remove hoist name plate cover (18W17 & 18W22) and disconnect wires from motor in Reversing Switch 77W1 or 77W1A. Remove four long screws (13) and pull off Stator (27). Rotor (28) remains in hoist. Caution should be exercised when removing Stator to avoid bending Rotor Shaft or damaging windings. Spread open brake shoes and pull out Rotor (28).

The Rotating Switch (16) is on the end of the Rotor shaft. Test the spring action with fingers.

Remove the End Bell (12) from the Motor Frame (27) and examine the switch contacts (17). The Stationary Switch (17) and the Reversing Relay (15) (15A) (15B) are mounted on the inside of the End Bell. They are connected to the Capacitor (18) which is mounted on Motor Frame (27). Contacts should be clean and free from pitting to make proper contact. Do not disconnect wiring unless making replacements.

The Brake Drum, Ball Bearing, Oil Seal, and Pinion can be removed by taking out Pin from the Pinion. To remove bearing use a bearing puller.

To Assemble

Reverse Disassembling Instructions.

Make sure that Pinion Pin is riveted over on both sides of Pinion.

Follow wiring diagram when re-wiring.

MOTOR PARTS FIGURES USED ON WESTINGHOUSE SINGLE PHASE MOTORS

Yale Motor Code	Reversing Relay			Rotating Switch	Stationary Switch	Yale Motor Code	Reversing Relay			Rotating Switch	Stationary Switch
	15	15A	15B	16	17		15	15A	15B	16	17
AAW1	USE			USE	USE	FBW2	USE			USE	USE
AAW2	USE			USE	USE	FBW3	USE			USE	USE
AAW3	USE			USE	USE	FBW4	USE			USE	USE
AAW4	1/4 H.P. 115 V.	USE		USE	USE	FBW5	USE			USE	USE
AAW5	USE			USE	USE	FBW6		USE			
AAW6		USE				FBW7			USE		
AAW7			USE			FCW1	USE			USE	USE
AAW8			USE			FCW2	USE			USE	USE
ABW1	USE			USE	USE	FDW1	USE			USE	USE
ABW2	USE			USE	USE	FDW2	USE			USE	USE
ABW3	USE			USE	USE	FEW1	USE			USE	USE
ABW4	USE			USE	USE	FEW2	USE			USE	USE
ABW5		USE				FFW1	USE			USE	USE
ABW6			USE			MAW1	USE			USE	USE
ACW1	USE			USE	USE	MAW2	USE			USE	USE
ACW2	USE			USE	USE	MAW3	USE			USE	USE
ACW3	USE			USE	USE	MAW4	USE			USE	USE
ADW1	USE			USE	USE	MAW5	USE			USE	USE
ADW2	USE			USE	USE	MAW6		USE			
AEW1	USE			USE	USE	MAW7		USE			
AEW2	USE			USE	USE	MAW8			USE		
DAW1	USE			USE	USE	MAW9			USE		
DAW2	USE			USE	USE	MBW1	USE			USE	USE
DAW3	USE			USE	USE	MBW2	USE			USE	USE
DBW1	USE			USE	USE	MBW3	USE			USE	USE
DBW2	USE			USE	USE	MBW4	USE			USE	USE
DBW3	USE			USE	USE	MBW5		USE			
FAW1	USE			USE	USE	MBW6			USE		
FAW2	USE			USE	USE	MBW7			USE		
FAW3	USE			USE	USE	MEW1	USE			USE	USE
FAW4	USE			USE	USE	MEW2	USE			USE	USE
FAW5	USE			USE	USE	MEW3	USE			USE	USE
FAW6	USE			USE	USE	MEW4	USE			USE	USE
FAW7		USE				MFW1	USE			USE	USE
FAW8			USE			MFW2	USE			USE	USE
FAW9			USE			MFW3			USE		
FBW1	USE			USE	USE						

THE FIGURES MAY BE THE SAME BUT THE PART NUMBERS VARY

GENERAL ELECTRIC SINGLE-PHASE MOTORS

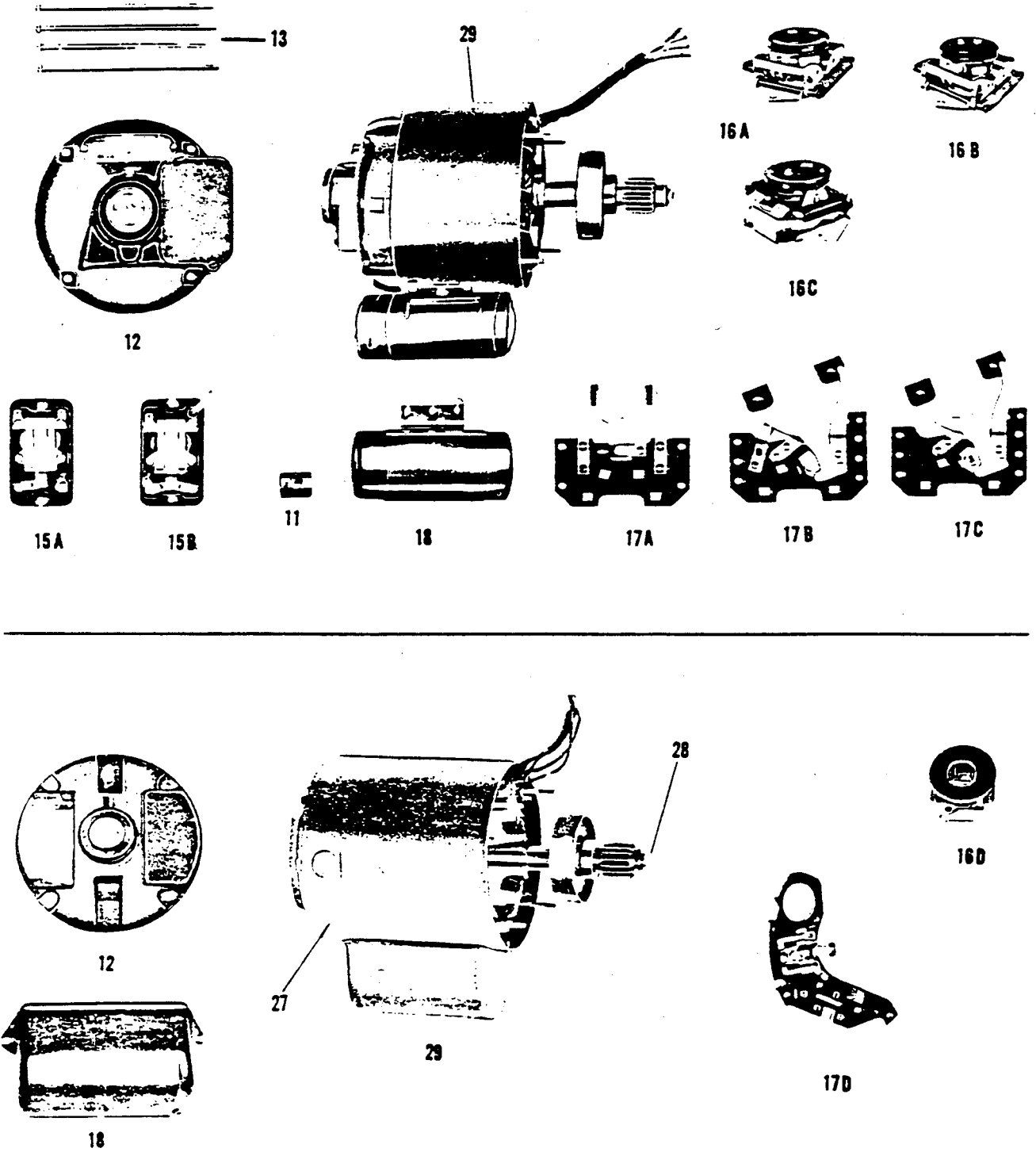

Above figures numbers refer to Master Spare Parts List which is in dealer's possession.

GENERAL ELECTRIC SINGLE-PHASE MOTORS

Part Name	Fig. No.	Quan.
Bearing—Plain Bushing	11	1
End Bell—with Bearing	12	1
Long Screw	13	4
*Reversing Relay—Complete	15A	1
*Reversing Relay—Complete	15B	1
*Rotating Switch	16A	1
*Rotating Switch	16B	1
*Rotating Switch	16C	1
*Stationary Switch	17A	1
*Stationary Switch	17B	1
*Stationary Switch	17C	1
Capacitor with Mounting	18	1 or 2
Complete Motor with Brake Drum, Ball Bearing and Pinion	29	1

Motor frame with wound primary (27) and rotor with shaft (28) cannot be supplied as spare parts.

*For parts used see Table on Page 12.

IMPORTANT

If motor repair parts are required give all information listed on hoist and motor name plates.

To Disassemble

Remove hoist name plate cover (18W17 & 18W22) and disconnect wires at Reversing Switch 77W1. Remove four long screws (13) and pull off Motor Stator. Rotor (28) remains in hoist. Caution should be exercised when removing Stator to avoid bending Rotor Shaft or damaging windings. Spread open brake shoes and pull out Rotor (28).

The Rotating Switch (16A) (16B) (16C) (16D) is on the end of the Rotor shaft. Test the spring action with fingers.

Remove the End Bell (12) from the Motor Frame (27) and examine the switch contacts. The Stationary Switch (17A) (17B) (17C) (17D) and the Reversing Relay (15A) (15B) are mounted on the inside of the End Bell. They are connected to the Capacitor (18) which is on the Motor Frame (27). They should be clean and free from pitting to make proper contact. Do not disconnect wiring unless making replacements.

The Brake Drum, Ball Bearing, and Pinion can be removed by taking out Pin from the Pinion. To remove bearing use a bearing puller.

To Assemble

Reverse Disassembling Instructions.

Make sure that Pinion Pin 45W71 is riveted over on both sides of Pinion.

Follow wiring diagram when re-wiring.

MOTOR PARTS USED ON SINGLE PHASE GENERAL ELECTRIC MOTORS

Yale Motor Code	Reversing Relay		Rotating Switch				Stationary Switch			
	15A	15B	16A	16B	16C	16D	17A	17B	17C	17D
AAG1	USE		USE				USE			
AAG2	USE		USE				USE			
AAG3		USE				USE		USE		
AAG4		USE				USE			USE	
AAG5						USE				USE
AAG6						USE				USE
ABG1	USE		USE				USE			
ABG2		USE				USE				
ABG3						USE				USE
ABG4						USE				USE
ACG1	USE			USE			USE			
ACG2		USE	USE				USE			
ACG3		USE				USE		USE		
ACG4		USE				USE		USE		
AEG1	USE			USE			USE			
AEG2		USE				USE		USE		
AFG1		USE				USE		USE		
AFG2						USE				USE
DAG1	USE		USE				USE			
FAG1	USE		USE				USE			
FAG2	USE		USE				USE			
FAG3		USE	USE				USE			
FAG4		USE	USE				USE			
FAG5		USE				USE		USE		
FAG6		USE				USE			USE	
FAG7						USE				USE
FAG8						USE				USE
FBG1	USE		USE				USE			
FBG2	USE		USE				USE			
FBG3		USE	USE				USE			
FBG4		USE				USE		USE		
FBG5						USE				USE
FBG6						USE				USE
FCG1	USE			USE			USE			
FCG2		USE	USE				USE		USE	
FCG3		USE				USE				
FDG1	USE			USE			USE			
FDG2		USE				USE		USE		
FEG1	USE			USE			USE			
FEG2	USE			USE			USE			
FEG3		USE		USE			USE			
FEG4		USE				USE		USE		
FFG1		USE				USE		USE		
FFG2		USE				USE		USE		
MAG1	USE		USE				USE			
MAG2	USE		USE				USE			
MAG3	USE		USE				USE			
MAG4		USE	USE				USE			
MAG5		USE				USE		USE		
MAG6										
MAG7						USE				USE
MAG8						USE				USE
MBG1	USE		USE				USE			
MBG2	USE		USE				USE			
MBG3		USE	USE				USE			
MBG4		USE				USE		USE		
MBG5		USE				USE		USE		
MBG6						USE		USE		
MBG7						USE				USE
MBG8						USE				USE
MEG1	USE		USE				USE			
MEG2	USE		USE				USE			
MEG3		USE	USE				USE			
MEG4		USE				USE		USE		
MEG5						USE				USE
MEG6						USE				USE
MFG1		USE				USE		USE		
MFG2		USE				USE		USE		
MFG3						USE				USE
MFG4						USE				USE
MXG1						USE				USE
MXG2						USE				USE
MXG3						USE				USE

D COVERS GE FORM "G" MOTOR

LOAD BRAKE

If the Load Brake fails to hold the load it may be an indication that the brake discs are worn and in that case must be replaced.

To Disassemble

Pull Load Brake Assembly out of the hoist. Remove the Snap Ring (64W16), Ball Bearing (4W40) and pull off the Stop Washer (83W80). Unscrew High Speed Gear (28W40) (28W41) from Brake Disc Hub (52W15) which releases Ratchet Assembly (51WG11B). To replace Brake Disc (12W7) remove three Rivets (55W12H).

To Assemble

Replace Ratchet Assembly (51WG11B) and screw on High Speed Gear (28W40) (28W41) until it is tight. Replace Stop Washer (83W80) as shown in below drawing.

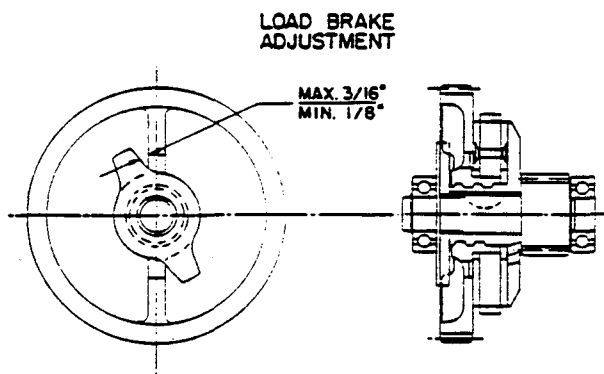

This clearance dimension must be held or the brake will jam. Replace Ball Bearing (4W40) and Snap Ring (64W16) To remove the Ball Bearings from the suspension frame and the gear case use a bearing puller.

POLYPHASE MOTORS

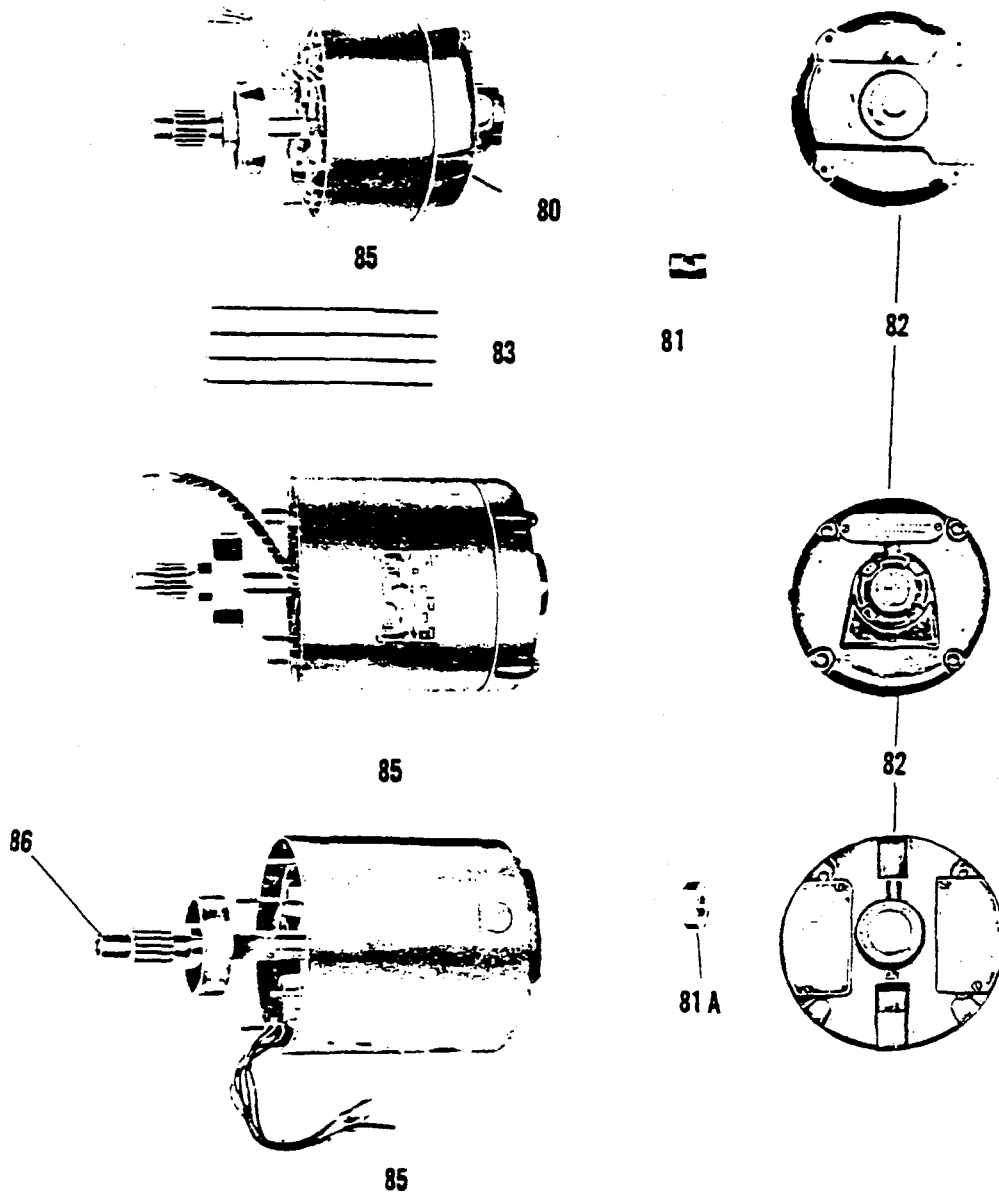

Part Name	Fig. No.	Quan.
Bearing—Plain Bushing, G.E. and Westinghouse.....	81	1
Bearing—Ball—Esco-Yale, Part No. 4W30.....	81A	1
End Ball—with Bearing.....	82	1
Long Screw.....	83	4
Complete Motor with Brake Drum, Ball Bearing and Pinion.....	85	1
(Cannot Be Supplied without Brake Drum Pinion and Bearing)		

POLYPHASE MOTORS

IMPORTANT

If motor repair parts are required give all information listed on hoist and motor name plates.

To Disassemble

Remove hoist name plate cover (18W17 & 18W22) and disconnect wires at Reversing Switch 77W1A. Remove four long screws (83) and pull off Stator (80). Rotor (86) remains in hoist. Caution should be exercised when removing Stator to avoid bending Rotor Shaft or damaging windings. Spread open brake shoes and pull out Rotor (86).

The Brake Drum, Ball Bearing and Pinion can be removed by taking out Pin from the Pinion. To remove Bearing use a bearing puller.

To Assemble

Reverse Disassembling Instructions.

Make sure that Pinion Pin is riveted over on both sides of Pinion.

Follow wiring diagram when re-wiring.

DIRECT CURRENT MOTORS

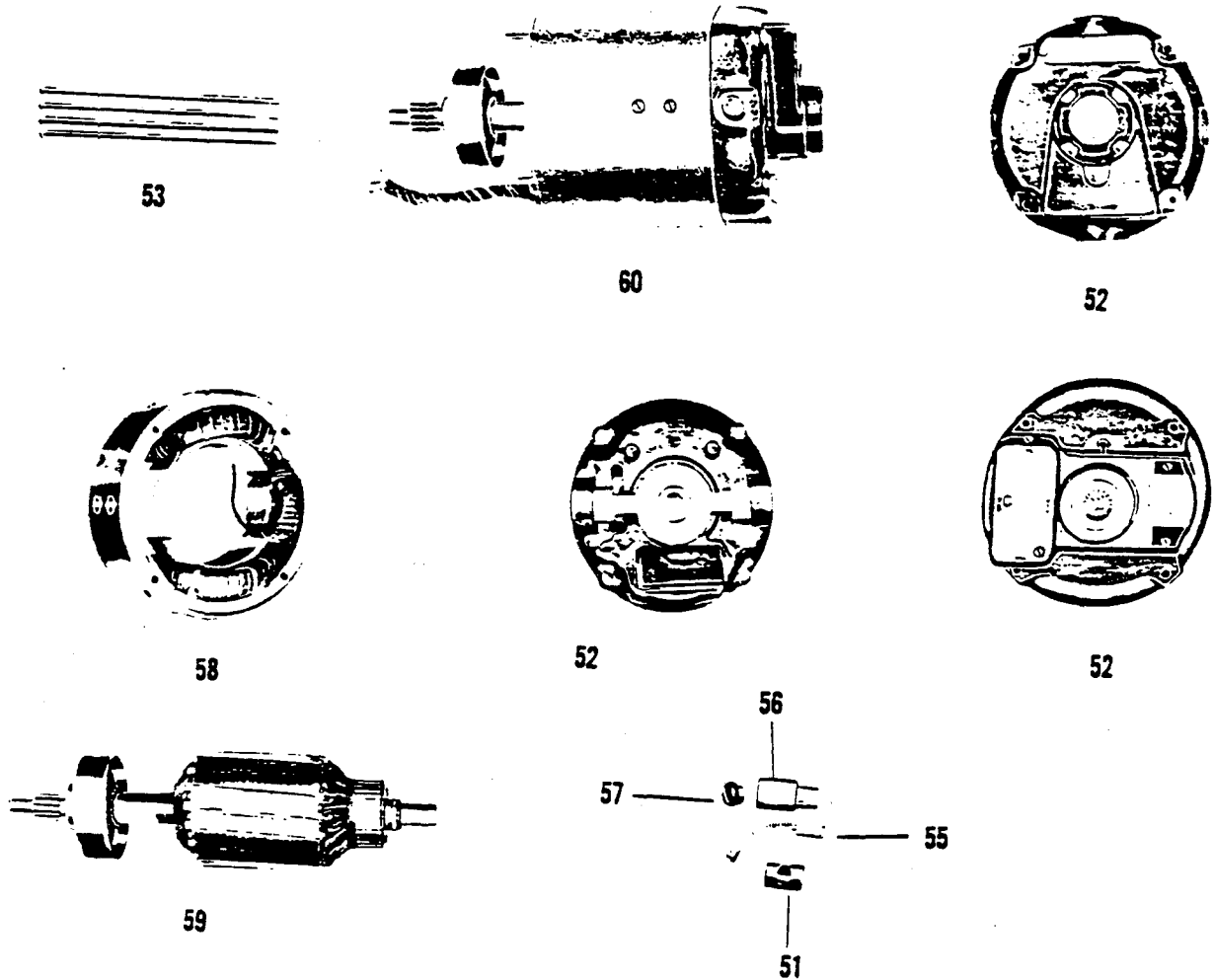

Part Name	Fig. No.	Quan.
Bearing—Plain Bushing	51	1
End Bell—with Bearing	52	1
Long Screw	53	4
Brush with Brush Spring	55	2
Brush Holder	56	2
Brush Holder Cap	57	2
Field Coils (complete set) without Pole Pieces	58	1
Complete Motor with Brake Drum, Ball Bearing and Pinion	60	1

Armature and shaft (59) cannot be supplied as spare parts.

DIRECT CURRENT MOTORS

IMPORTANT

If motor repair parts are required give all information listed on hoist and motor name plates.

To Disassemble

Remove Brush Holder Caps (57) pull out Brushes (55). Remove hoist name plate cover (18W17 & 18W22) and disconnect wires at Reversing Switch 77W1A. Remove four long screws (53) and pull off Motor Housing with Field Coils (58). Armature (59) remains in hoist. Caution should be exercised when removing field coils to avoid bending armature shaft or damaging windings. Spread open brake shoes and pull out Armature (59).

To remove the Brushes (55) first unscrew the Brush Holder Caps (57) and the Brush and Brush Spring can be pulled out of Motor.

Check commutator for smoothness and cleanliness.

Check brushes for smoothness, cleanliness and pressure on commutator.

If commutator is rough, clean with sandpaper, *Not Emery Cloth*.

If brushes are worn or spring pressure is light, replace.

The Brake Drum, Ball Bearing, and Pinion can be removed by taking out Pin from the Pinion. To remove other bearings use a bearing puller.

To Assemble

Reverse Disassembling Instructions.

Make sure that Pinion Pin is riveted over on both sides of Pinion.

Consult wiring diagram when re-wiring.

YALE

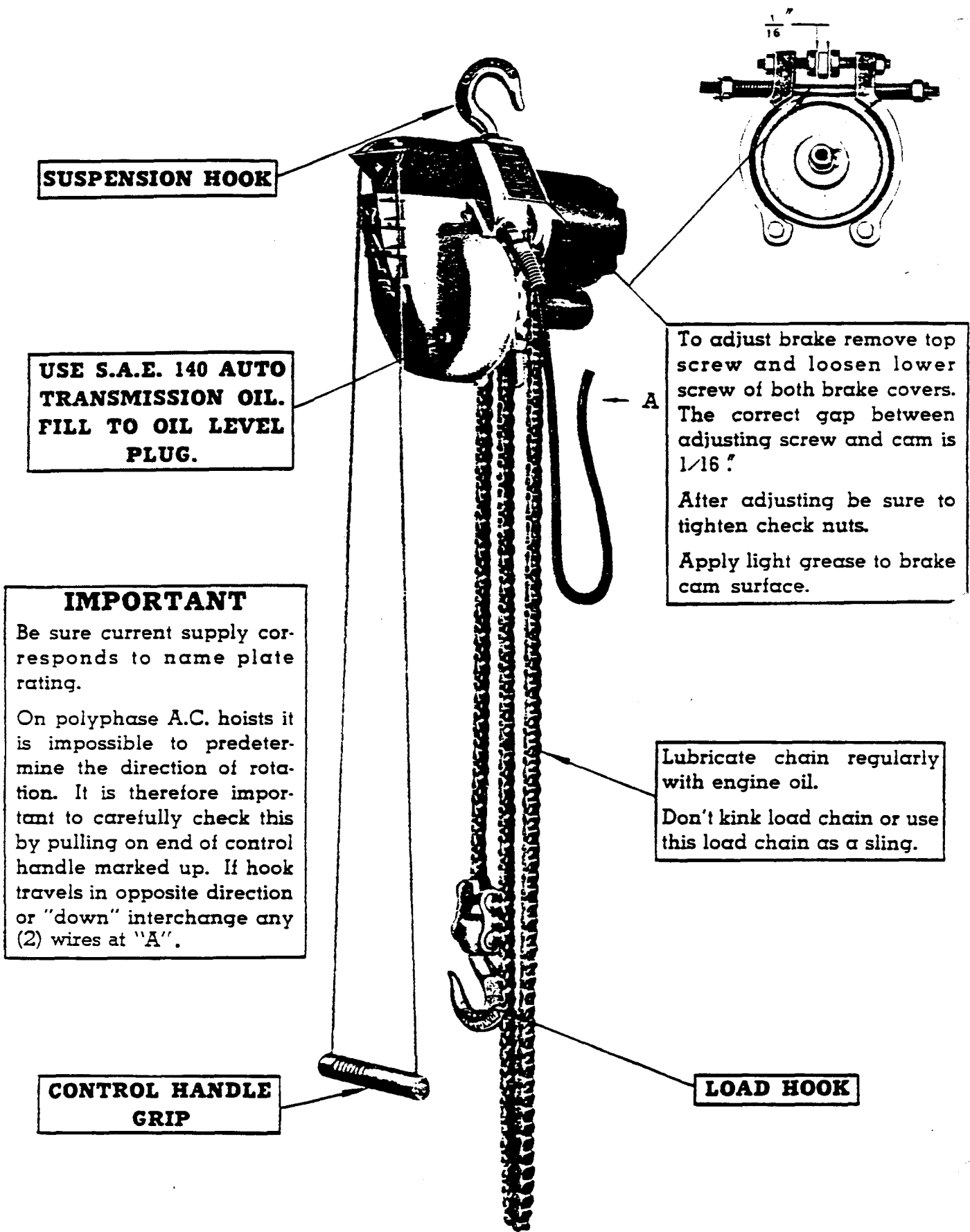

SUSPENSION HOOK

USE S.A.E. 140 AUTO TRANSMISSION OIL. FILL TO OIL LEVEL PLUG.

IMPORTANT

Be sure current supply corresponds to name plate rating.

On polyphase A.C. hoists it is impossible to predetermine the direction of rotation. It is therefore important to carefully check this by pulling on end of control handle marked up. If hook travels in opposite direction or "down" interchange any (2) wires at "A".

CONTROL HANDLE GRIP

To adjust brake remove top screw and loosen lower screw of both brake covers. The correct gap between adjusting screw and cam is $\frac{1}{16}$ ".

After adjusting be sure to tighten check nuts.

Apply light grease to brake cam surface.

Lubricate chain regularly with engine oil.

Don't kink load chain or use this load chain as a sling.

LOAD HOOK

YALE HOISTS

"Industry's MUSCLES of STEEL"

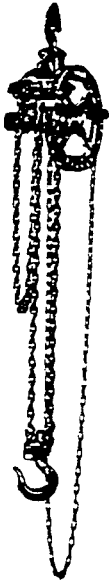

SCREW GEARED HOIST

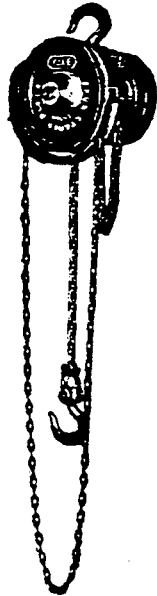

SPUR GEARED HOIST

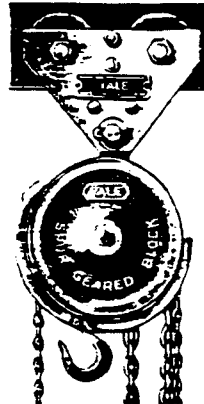

CLEVIS TYPE HOIST

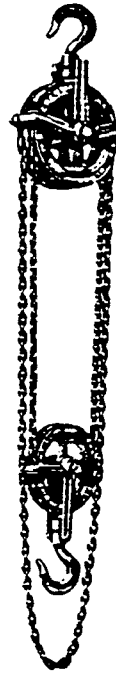

DIFFERENTIAL HOIST

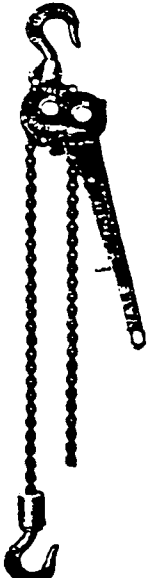

PUL-LIFT



All Yale Hoists are tested to 50% overload—Recommended only for use with loads within rated capacity and warranty applies only up to the rated capacity.

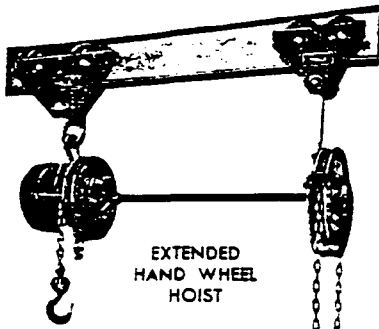

EXTENDED HAND WHEEL HOIST

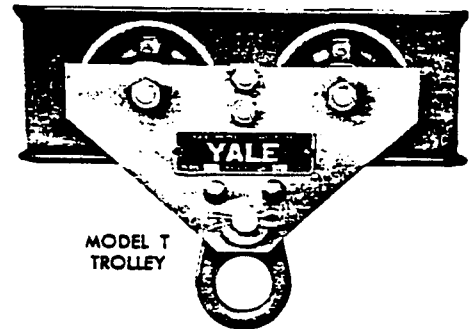

MODEL T TROLLEY

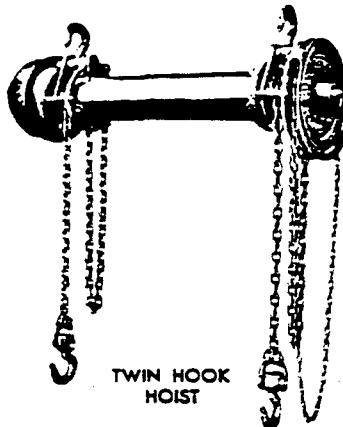

TWIN HOOK HOIST

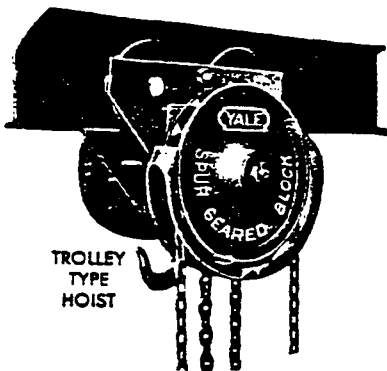

TROLLEY TYPE HOIST

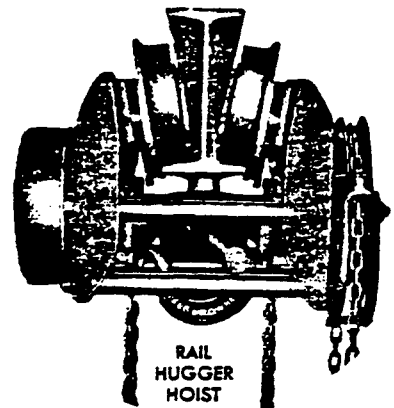

RAIL HUGGER HOIST

THE YALE & TOWNE MFG. CO.

Philadelphia 15, Pa., U. S. A.