

ASSEMBLY INSTRUCTION MANUAL
EASY CONNECT CRANE KIT
Festoon Conductor Systems



Mounting Instructions

CONTENT

	Page
1. Kit Contents	3
2. Complete system layouts	
2.1 Steel Track Festoon System with tow arm assembly	4
3. Mounting Steps	5
3.1 Mounting preparations	5
3.2 Festoon system assembly	6
3.2.1 C-Rail mounting to bridge girder	6
3.2.2 Mounting of end stops in the tracks	6
3.2.3 Track support bracket	6 - 7
3.2.4 Track coupler	7
3.2.5 End stop	7
3.2.6 End clamp	7
3.2.7 Installation of the cable systems	8
3.2.7.1 Festoon cable systems	8
3.2.7.2 Motor, main collector connection cables	8
3.2.7.3 Control pendant station	8
3.2.8 Connection to hoist and trolley - towing arrangement	8
3.2.9 Bridge Panel Mounting	8
4. Special Precautions During Assembly	8
Festoon Cable Plug Connections	9
Mounting the Bridge Panel	10
Interconnecting Wiring Diagram	11
Typical Arrangements Possible (Figures A-C)	12 - 13

Mounting Instructions

Easy Connect Crane Kits “Plug & Play” Festoon Systems Bill of Material per Span per Type of Hoist

Components		Qty. Per Span									
Description	Part Number	Hoist Section A					Hoist Section B				
		20'	30'	40'	50'	60'	20'	30'	40'	50'	60'
		450320-22	450320-32	450320-42	450320-52	450320-62	450321-20	450321-30	450321-40	450321-50	450321-60
Track 6M - (19' - 8")	S-023201-6	2	2	4	4	6	2	2	4	4	6
Track 4M - (13' - 1")	S-023201-4		2		2			2		2	
Track Supports (5ft. Centers)	S-023222-1	10	14	20	22	28	10	14	20	22	28
Track Coupler	S-023210	0	2	2	4	4	0	2	2	4	4
Support Arms 60"	S-020276-1520	2	2	2	2	2	7	9	11	13	15
Support Arms 53"	S-020276-1340	5	7	9	11	13					
Track nuts/bolts for bridge panel	200-09C006	4	4	4	4	4	4	4	4	4	4
Girder Clips S beam	S-020181-08	14	18	22	26	30	14	18	22	26	30
Tow Arm, Mtg. Arm and Hardware	A200-09-C004F	1	1	1	1	1	1	1	1	1	1
Cable Clips for SO Power Cables*	S-23790-1	5	7	9	11	13	5	7	9	11	13
Tow Trolley	S-023577	1	1	1	1	1	1	1	1	1	1
Intermediate Trolley	S-023261	6	8	10	12	14	6	8	10	12	14
End Clamp	S-023579/551	2	2	2	2	2	2	2	2	2	2
Control Trolley	S-023178-16/554	1	1	1	1	1	1	1	1	1	1
End Stop	S023215	2	2	2	2	2	2	2	2	2	2
PVC flat festoon cable 8C #16 **	130-2-16-08	35	45	55	65	75	35	45	55	65	75
PVC flat festoon cable 4C #12 **	130-2-12-04	35	45	55	65	75					
PVC flat festoon cable 4C #10 **	130-2-10-04						35	45	55	65	75
PVC flat festoon cable 8C #16 **	130-2-16-08	31	41	51	61	71	31	41	51	61	71
6-pole Male Plug Insert	447198-01	1	1	1	1	1	1	1	1	1	1
6-pole Female Socket Insert	447198-21	1	1	1	1	1	1	1	1	1	1
6-pole Hood Housing	A140-09-C001	2	2	2	2	2	2	2	2	2	2
10-pole Male Plug Insert	447198-02	1	1	1	1	1	1	1	1	1	1
10-pole Female Socket Insert	447198-22	1	1	1	1	1	1	1	1	1	1
10-pole Hood Housing	A140-09-C002	2	2	2	2	2	2	2	2	2	2
16-pole Male Plug Insert	447198-03	1	1	1	1	1	1	1	1	1	1
16-pole Hood Housing	A140-09-C003	1	1	1	1	1	1	1	1	1	1

*Shipped separate are the following power connections cables:

Components		Cable Length				
Description	Part Number	20'	30'	40'	50'	60'
Bridge panel to collectors & Near Motor	117855-01					
Bridge panel to motor opposite bridge panel - length varies	448661-XX	26	36	46	56	66
Pendant station	Varies with hoist					

**Cable lengths include 10 ft. of hook up on panel end and 5 ft of hook up on hoist end. Cable length for pendant will have 10 ft. of hook for panel and 1 extra foot for connection to Pendant Trolley.

Hoist Selection A

Electric Chain Hoists, Shaw-Box 700 & 800 Series.

Hoist Selection B

World Series and Global King

Mounting Instructions

Steel Track Festoon System

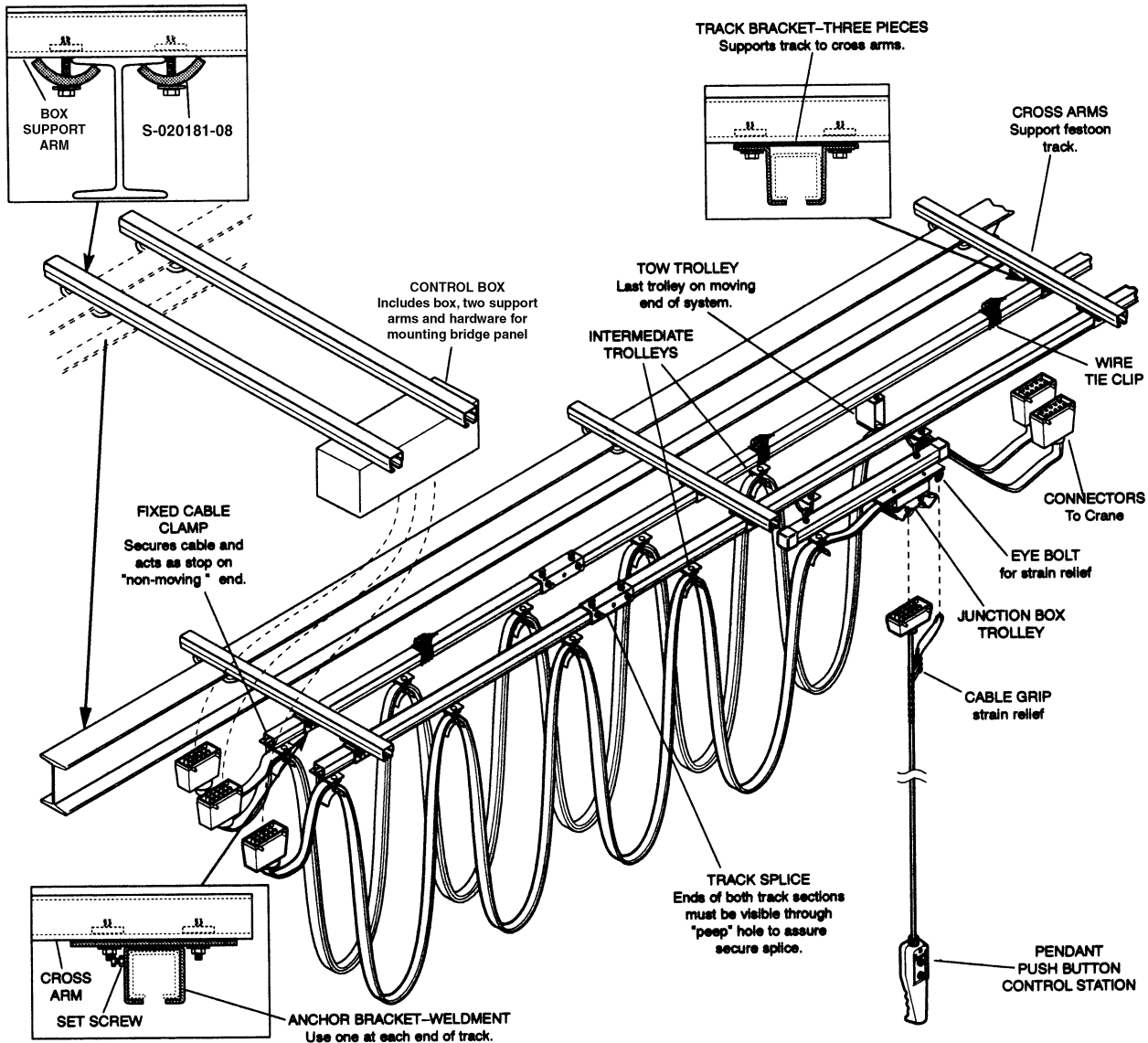

INSTALLATION OVERVIEW

1. Clamp cross arms to supporting I-beam. Spacing between arms must not exceed 6' (1.8m) on center. Securely tighten clamps.
Note: Use channel clamps (provided) for both cross arms and control box support rails if beam is capped with channel.
2. Hang festoon rail sections from bottom of arms using anchor brackets (one each end of system) and track brackets. Use track splices to join track sections. View through hole in splice to make sure both sections of track are inserted half way. Carefully level and align track. Securely tighten all set screws on anchor brackets and splice brackets. **Note:** Festoon systems come in ten foot increments. If required, cut off last c-rail sections. If more than 5' is cut off, it may also be necessary to remove one trolley and adjust cable loops accordingly.
3. Insert end stop into ends of tracks opposite fixed end. Clamp tightly in place.
4. Insert tow trolley and junction box trolley into fixed end of appropriate track, followed by intermediate trolleys. (See illustrations above). Insert fixed cable clamp into track with stop angle on clamping bar facing in. Securely tighten in place.
5. Plug connectors on cable assemblies into control box, crane or pendant control.
6. Snap on wire tie clips at desired locations.
7. Install Tow Arm Kit as shown on opposite side.

TOW ARM INSTALLATION

1. Move festoon tow trolley into position next to Crane trolley. Measured height from opening in tow trolley to hoist side plate.
2. Mount support channel in tapped holes on hoist side plate using 1/2" x 1" hex head bolts. See illustration at right.
3. Assemble Tow Arm Weldment to Support Channel at appropriate height using 1/2" x 1 1/2" hex head bolts, lock washers and hex nuts. Square tub on Tow Arm Weldment must be in center of and extended through opening on tow trolley.
4. Slowly run hoist through entire length of travel. Check for binding in tow trolley opening or obstruction to tow arm.

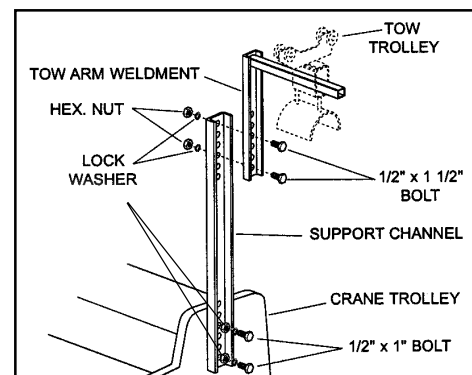

Mounting Instructions

3. Mounting Steps

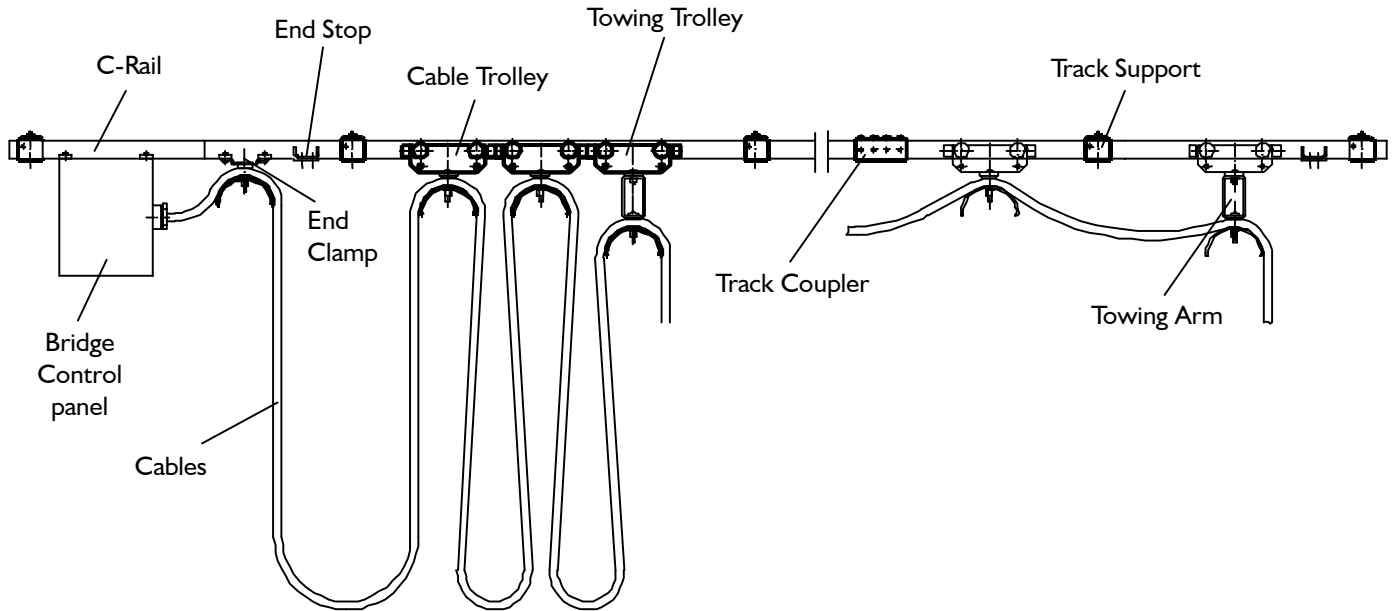

3.1 Mounting Preparations

Refer to page 4 to familiarize yourself with the arrangement of a finished system before starting. Then determine which end of the crane the bridge control panel will be mounted at. This is the starting point of the system where all cables connect into the bridge control panel and is to be at the main collector end of the bridge.

Once it is known how the system will be mounted on the bridge mark the top flange of the girder to indicate the mounting locations of the track and panel support arms. The festoon track support arms are to be spaced at 5' - 0" center- to-center (no more than 6' - 0") beginning 18" in from the end of the bridge girder.

The bridge control panel support arms are only for the support of the panel and can be mounted on the same side as the festoon conductor tracks or on the opposite side. The bridge panel support arms are to be mounted centered at 12" to align with the track nuts in the top of the panel's enclosure. The panel must be mounted so as to clear any obstructions (end trucks, bracing and hoist) yet close enough for the festoon cables, motor power connection cables and main collector cable to reach the panel.

Mounting Instructions

3.2 Festoon System Assembly

3.2.1 C-Rail Mounting to Bridge Girder

Illustration: Rail mounting with support arms on the upper flange

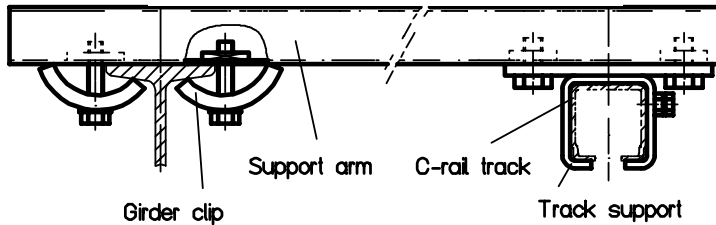

To mount the track support arms slide two girder clips into the support arm (note the two longer arms supplied with the 700/800 series kit are the bridge panel support arms). Do not tighten the clip bolts, spread them apart enough to allow straddling the top flange of the bridge beam, extend the arm to the required distance and tighten the girder clip bolts. If a capping channel with deep legs is used it may be required to weld the support arms to the top flange.

Once the track support arms are secured to the bridge girder's top flange slide in two track support brackets into each arm, one for the festoon cross conductor track and one for the festoon pendant station track. Position and space the brackets to the required distance and spacing and tighten the bolts.

Then slide the long runs of track into the support brackets, couple the ends of the track together (splice couplings used on spans greater than 20') and tighten the hardware to secure the track.

Following are installation details for mounting the hardware

3.2.2 Mounting of end stops in the tracks

Install the end stops in the rail at the ends opposite the bridge control panel

3.2.3 Track Support Bracket

Illustration: Track support bracket with locking screw

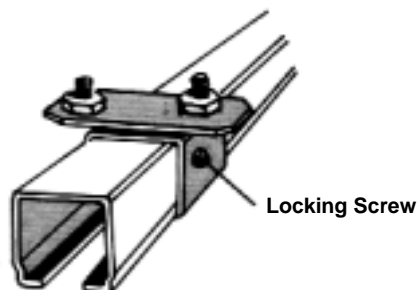

The track support brackets are slipped onto the C rail and mounted to the support arm with the rail. Clamp the C-rail in the track support bracket with the locking screw. Alternatively, it is also possible to mount the track support brackets to the support arm first, and insert the C rail sections and clamp them with the locking screws afterwards.

Mounting Instructions

3.2.3 Track Support Bracket

Illustration: Securing the rail against sliding

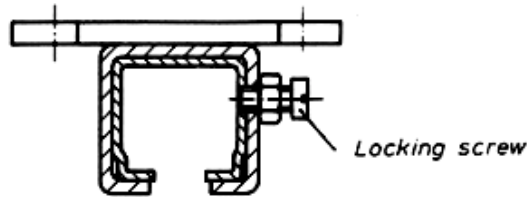

In the first and last track support bracket the C rail has to be secured against sliding in the horizontal direction. Therefore, 6.2 millimeter diameter holes are drilled into the side of the rail for the locking screws.

Note: The locking screws can not dent or bend the inner wall of the rail as the rollers of the trolleys may be damaged.

3.2.4 Track Coupler

Illustration: Track Coupler

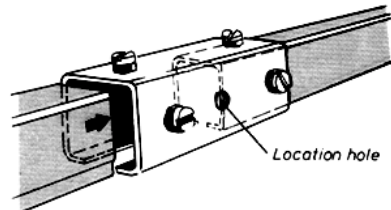

The track coupler is slid halfway onto the first joint of the C rail and then clamped. The correct position can be verified at the sight hole of the coupler. The second C rail piece is inserted and clamped gap-free. The C-rails need to be cut at a right angle and deburred. Be sure that the locking screws are tightened equally to avoid any displacement of the rails in the coupler area.

3.2.5 End Stop

Illustration: End Stop

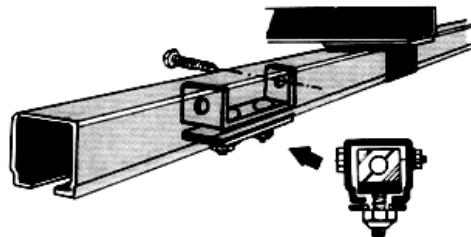

The end stop is inserted into the C rail and clamped at the end of the travel distance of the festoon.

3.2.6 End Clamp

The end clamp is inserted behind the end stop and then clamped tightly.

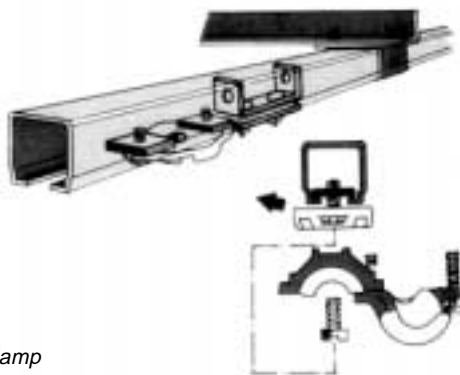

Illustration: End Clamp

Mounting Instructions

3.2.7 Installation of the Cable Systems

3.2.7.1 Festoon cable systems

A flat cable festoon system is comprised of two runs of track running the length of the crane bridge with trolleys carrying flat cables for power and control transmission. The track closest to the bridge girder contains the festoon cross conductors that supply power and control to the hoist and trolley, the other is for the festoon control pendant station.

There are two sets of cables provided with carrier trolleys and connection plugs mounted for easy installation. The festoon cross conductor cable assembly has a tow trolley with an extended "pocket" for the trolley's tow arm and plugs marked 1 & 3 and 2 & 4. This arrangement goes in the track closest to the bridge girder, tow trolley end first. The festoon control pendant cable assembly has a control trolley where the pendant cable plugs into at one end. The control trolley end goes in first.

Each run of festoon track is provided with an end stop for one end to prevent the cable trolleys from running out and a cable end clamp for mounting at the bridge control panel end of the track to secure the cable.

3.2.7.2 Motor, main collector connection cables.

In addition to the trolley suspended festooned cables there are three round (SO) power connection cables shipped in a separate package. One is a 15' - 0" long cable with a single connection plug for the bridge panel and leads to wire into the main collectors. One is a 10' - 0" long cable with two connection plugs to connect the bridge panel with the bridge drive motor adjacent to the panel. The third varies with the span of the crane and connects the panel to the bridge drive motor at the opposite end of the crane. The third cable lies across the festoon track support arms and is held to the arms with Cable Clips Part Number S-23790-1. The clips snap onto the topside of the support arms and have a wire tie that secures the SO motor power cable to them.

3.2.7.3 Control pendant station

The pendant station SO control cable is wired into a plug half that facilitates easy connection plugging into a mating half on the control trolley. There is also a strain reliever cable running alongside and attached to the SO cable with the cable's termination wrapped around a "tear drop" fitting and secured with a clamp.

The strain reliever cable must be attached to the eyebolt on the control trolley and shorted if required to provide slack in the control cable prevent it from being torn out of its' plug. To shorten and attach the strain cable to the control trolley, loosen up the cable clamp and remove the cable from the clamp. Then slip the "tear-drop" fitting and cable over the control trolley eyebolt. After this step is complete, pull the strain reliever cable up over the fitting and through the eyebolt until the SO control cable has adequate slack and tighten the strain reliever cable clamp.

3.2.8 Connection to Hoist & Trolley - Towing Arrangement

Tow arm assembly and mounting to the hoist's trolley frame is illustrated on page 4. The tow arm has two sections with multiple mounting holes permitting a wide range of adjustability accommodating most all trolley and beam depth requirements. The horizontal portion of the tow arm protrudes through the festoon cross conductor's tow trolley's "towing box" allowing the moving hoist and trolley to push and pull the festoon cables along with it. Check to insure that the horizontal portion of the tow arm does not interfere with the festoon pendant cables. If it does, cut the section back.

3.2.9 Bridge Panel Mounting

The bridge control enclosure has four (4) holes in the top for the mounting hardware that consists of four (4) sets of a bolt, flat washer and square track nut. The bolt and flat washer are inserted through the mounting holes from inside the enclosure with the track nuts fastened (do not tighten) to the bolts outside of the enclosure.

The panel is mounted to it's support arms by sliding the track nuts into the arms, positioning the panel the required distance from the girder and tightening the bolts.

4. Special Precautions During Assembly

During the assembly of the track it is recommended that you check for trouble-free movement of the trolleys within the rail with the help of one of the supplied cable trolleys. If a trolley with horizontal guide rollers is used, even a slight lateral imperfection of the rail can cause a jamming of the trolleys.

Festoon Cable Plugs Connections

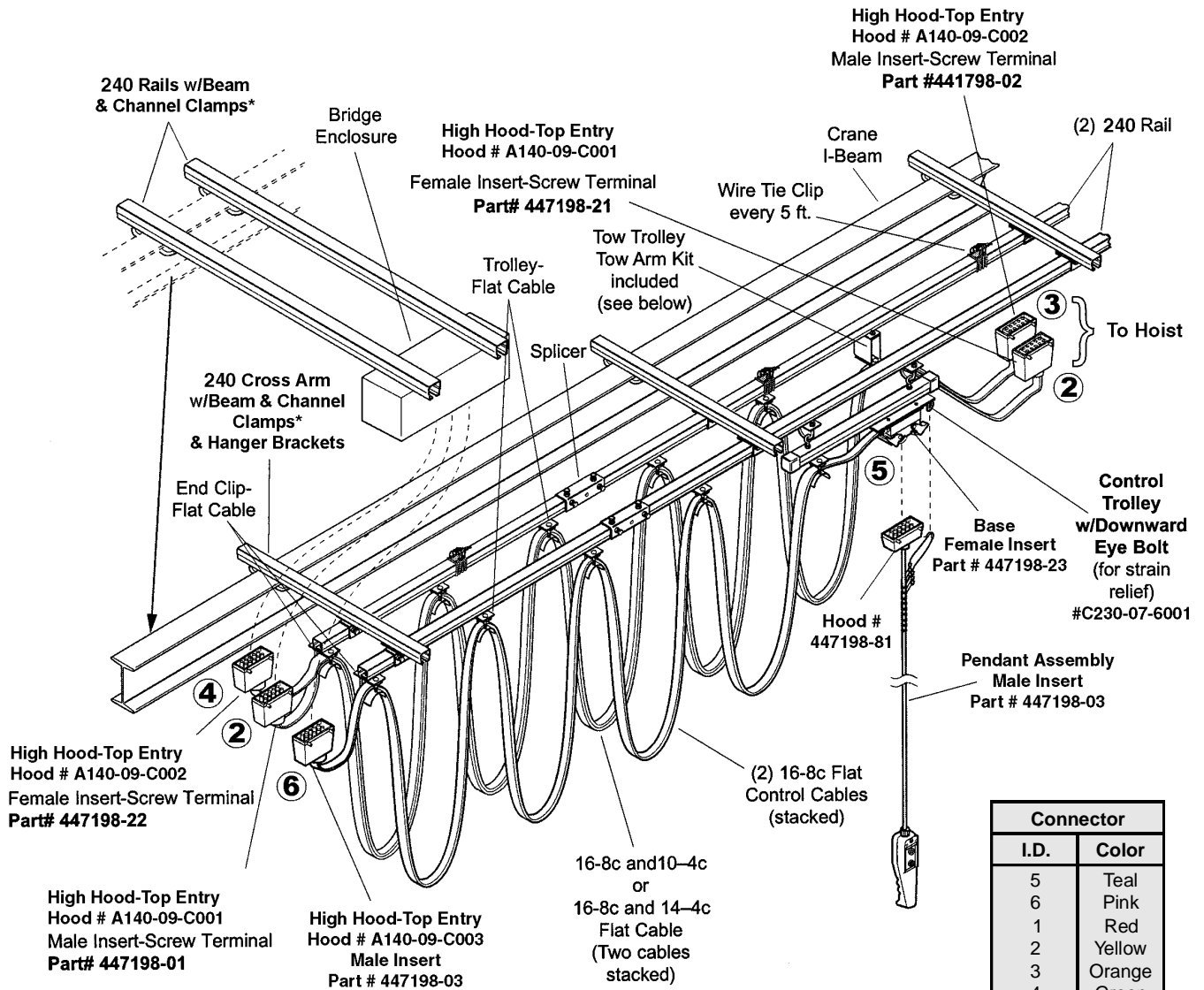

Mounting the Bridge Panel

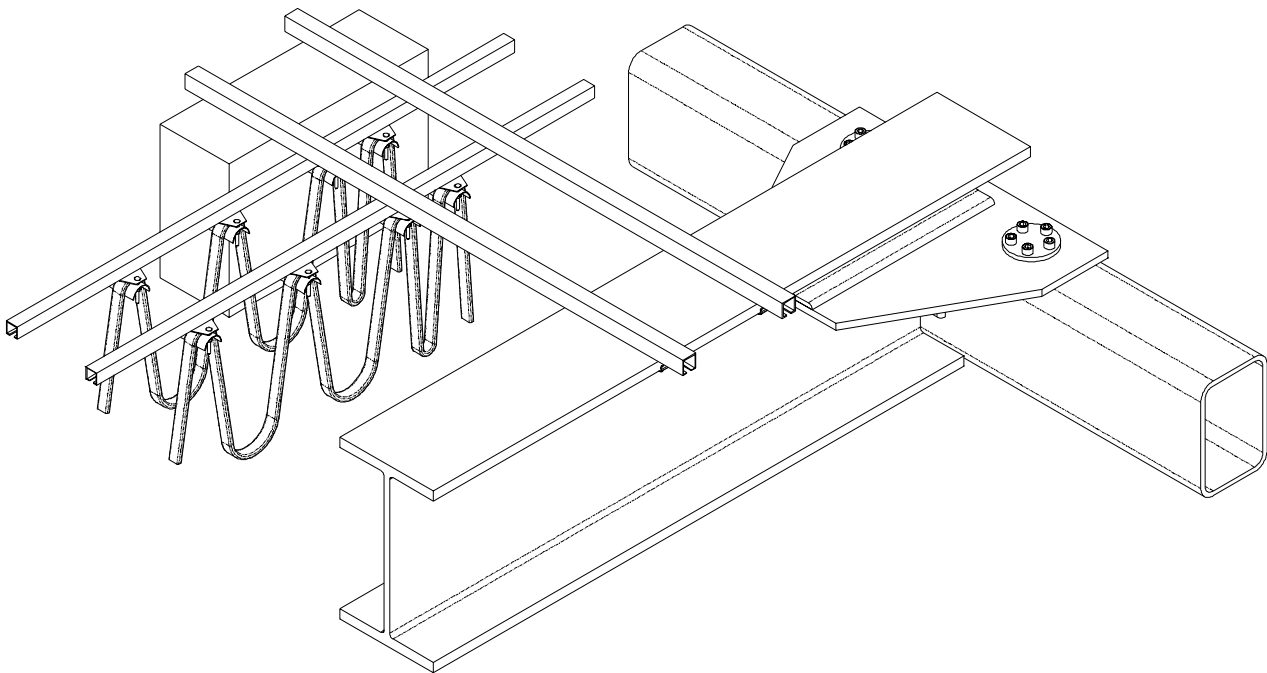
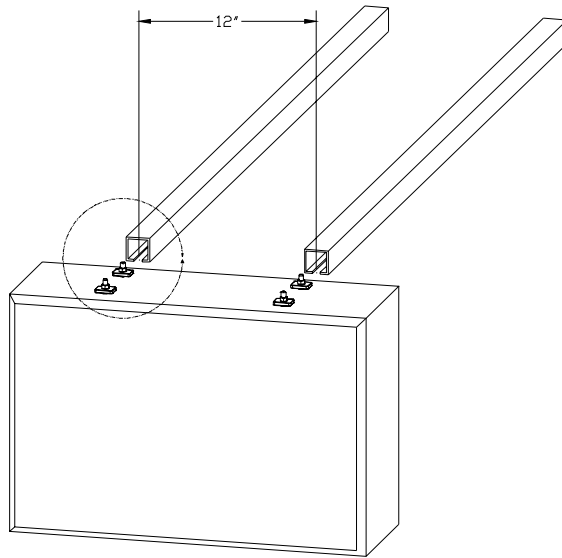
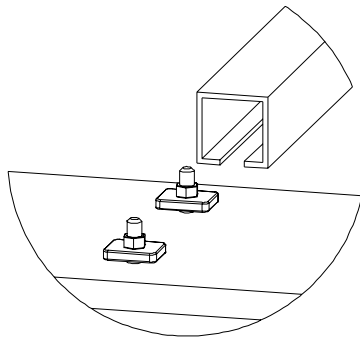

The festoon kit comes with four 1-inch long bolts for hanging the bridge panel. Insert each bolt with a lock washer and the sealing rubber washer through the panel from the inside with the threads facing the outside. Make sure the rubber side of the washer is against the panel to maintain the type 4 rating. Twist a square nut on each bolt two or three full turns. Hang the bridge panel by sliding the square nuts onto the track. Tighten the bolts from inside the panel.

CONNECTOR				
NUMBER	TYPE	LABEL COLOR	LABEL PART #	
1	B	RED	117590-01	
2	B	YELLOW	117590-02	
3	C	ORANGE	117590-03	
4	C	GREEN	117590-04	
5	A	TEAL	117590-05	
6	A	PINK	117590-06	
7	C	PURPLE	117590-07	
8	C	BROWN	117590-08	
9	D	VIOLET	117590-09	

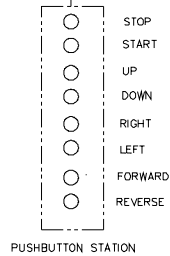
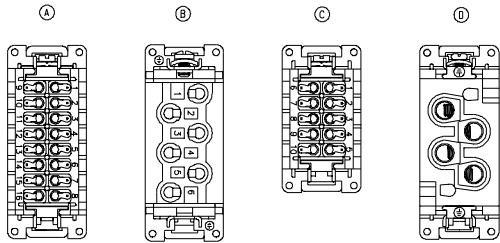
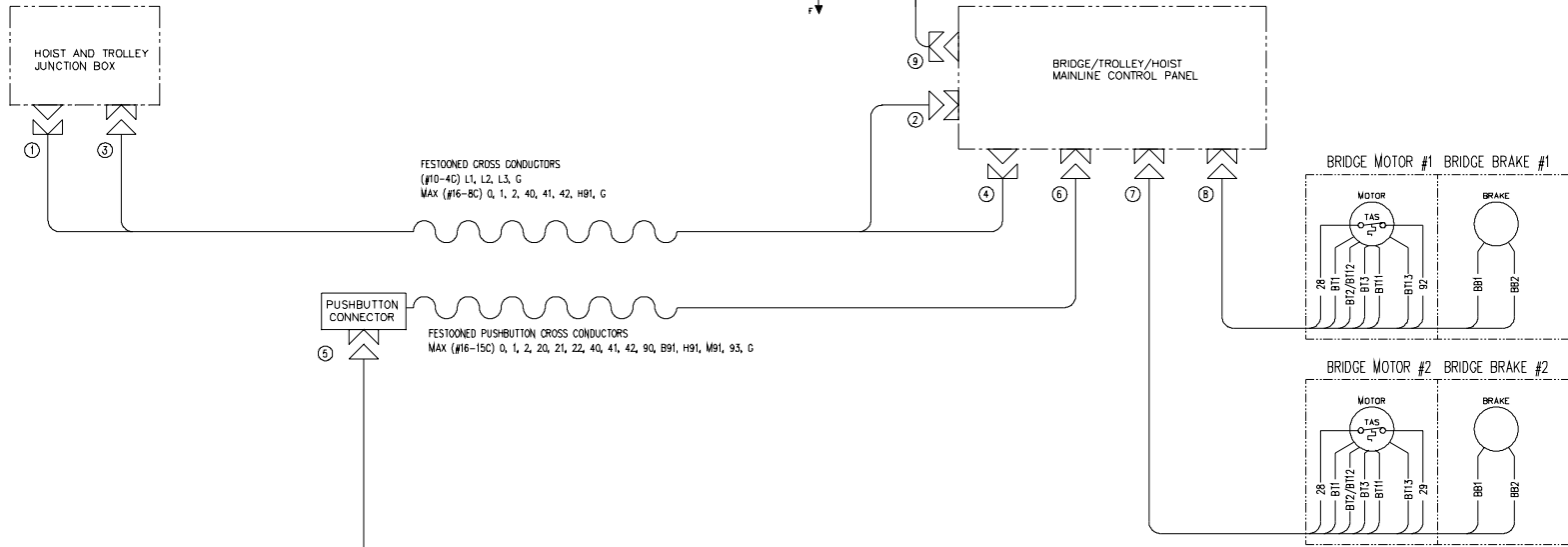

CONNECTOR 1 AND 2	
WIRE #	PIN #
L1	1
L2	2
L3	3
NONE	4
NONE	5
NONE	6
G	GROUND

CONNECTOR 3 AND 4	
WIRE #	PIN #
1	1
2	2
0	3
40	4
41	5
42	6
H91	7
NONE	8
NONE	9
NONE	10
G	GROUND

CONNECTOR 5 AND 6	
WIRE #	PIN #
1	1
2	2
0	3
20	4
21	5
22	6
40	7
41	8
42	9
90	10
B91	11
H91	12
M91	13
93	14
92	15
NONE	16
G	GROUND

CONNECTOR 7	
WIRE #	PIN #
BT1	1
BT2	2
BT3	3
BT11	4
BT13	6
28	7
29	8
B91	9
B92	10
G	GROUND

CONNECTOR 8	
WIRE #	PIN #
BT1	3
BT2	2
BT3	1
BT11	6
BT13	4
28	7
29	8
B91	9
B92	10
G	GROUND

CONNECTOR 9	
WIRE #	PIN #
RL1	1
RL2	2
RL3	3
NONE	4
G	GROUND



FIRST USED ON

NO.	CHANGE	DATE	ITL	INTERCONNECTION WIRING DIAGRAM
1	RELEASED DRAWING	02/07/01	SJDA	PLUG AND PLAY
2	CHANGED SCHEMATIC LAYOUT			
	BT12 REMOVED FROM CONNECTORS	03/21/01	SJDA	
3	SWAPPED BT1 TO PIN 3 - BT13 TO PIN 4	08/06/05	SJDA	
	BT11 TO PIN 6 - BT13 TO PIN 4 ON CB			

SC: LPT-TECH INTERNATIONAL, division of COLLEGE HIKARU CORPORATION
DA: 01/10/01
DR: SJDA
SHEET 01 OF 1 SHEETS

447646

INTERCONNECTION WIRING DIAGRAM

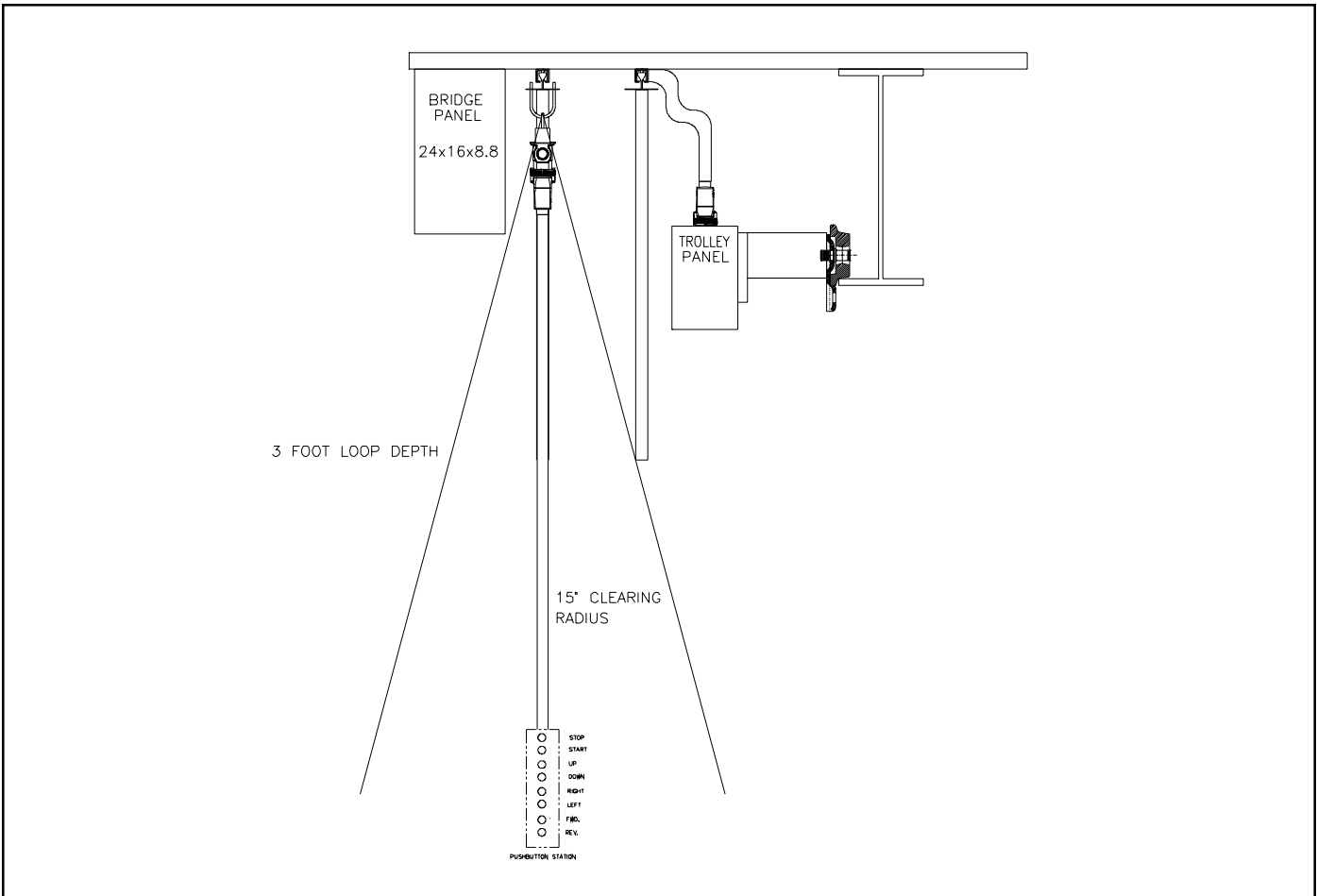

Figure A.

World Series / Global King Easy Connect

Install the bridge panel and festooning opposite side of the hoist control panel. The festoon cable will be long enough to cross the alignment bar and plug into the control panel.

700/800 Series Easy Connect

Depending on preferred clearance the bridge panel may be assembled to the girder different ways. In figure "A" the bridge panel extends past the pushbutton festoon. When constructed to this figure the bridge panel distance from the beam is at a maximum. In figure "B" the bridge panel is displayed in line with the pushbutton festoon. The distance from the girder is less than figure "A", except the pushbutton travel is limited slightly where the panel exists. The final way in figure "C" shows the bridge panel opposite of the festooning. When constructing the system to this figure the cables will need to pass over or around the girder to the panel.

Only a few variations shown, the system can be assembled many different ways depending on personal preferences.

⚠ WARNING
DO NOT UNPLUG CONNECTORS WHILE CIRCUIT IS ENERGIZED.
BEFORE PLUGGING IN CONNECTORS REMOVE POWER FROM SYSTEM

⚠ WARNING
Working in or near exposed energized electrical equipment presents the danger of electric shock.
TO AVOID INJURY: Disconnect power and lockout/tagout Disconnecting means before removing cover or servicing this equipment.

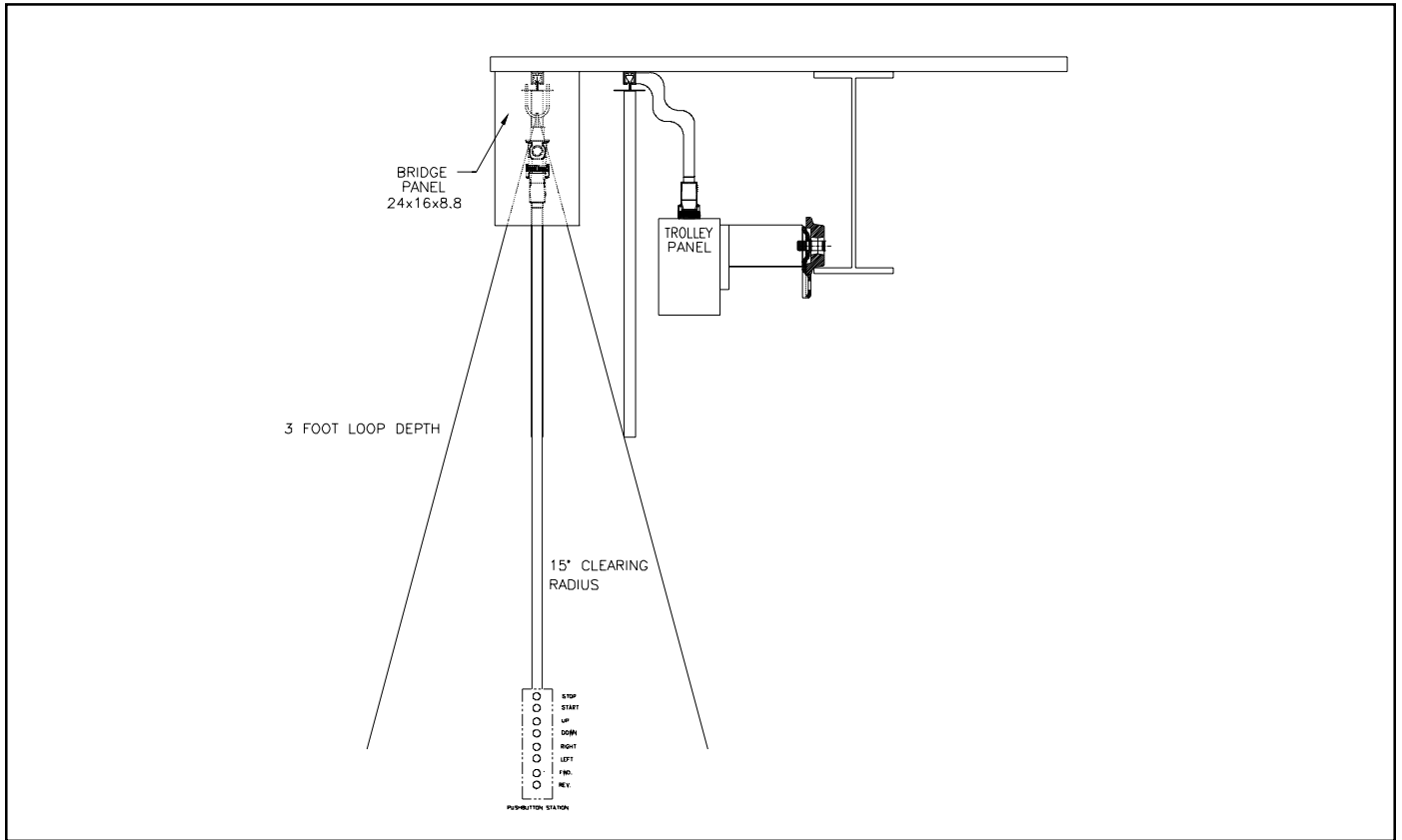

Figure B.

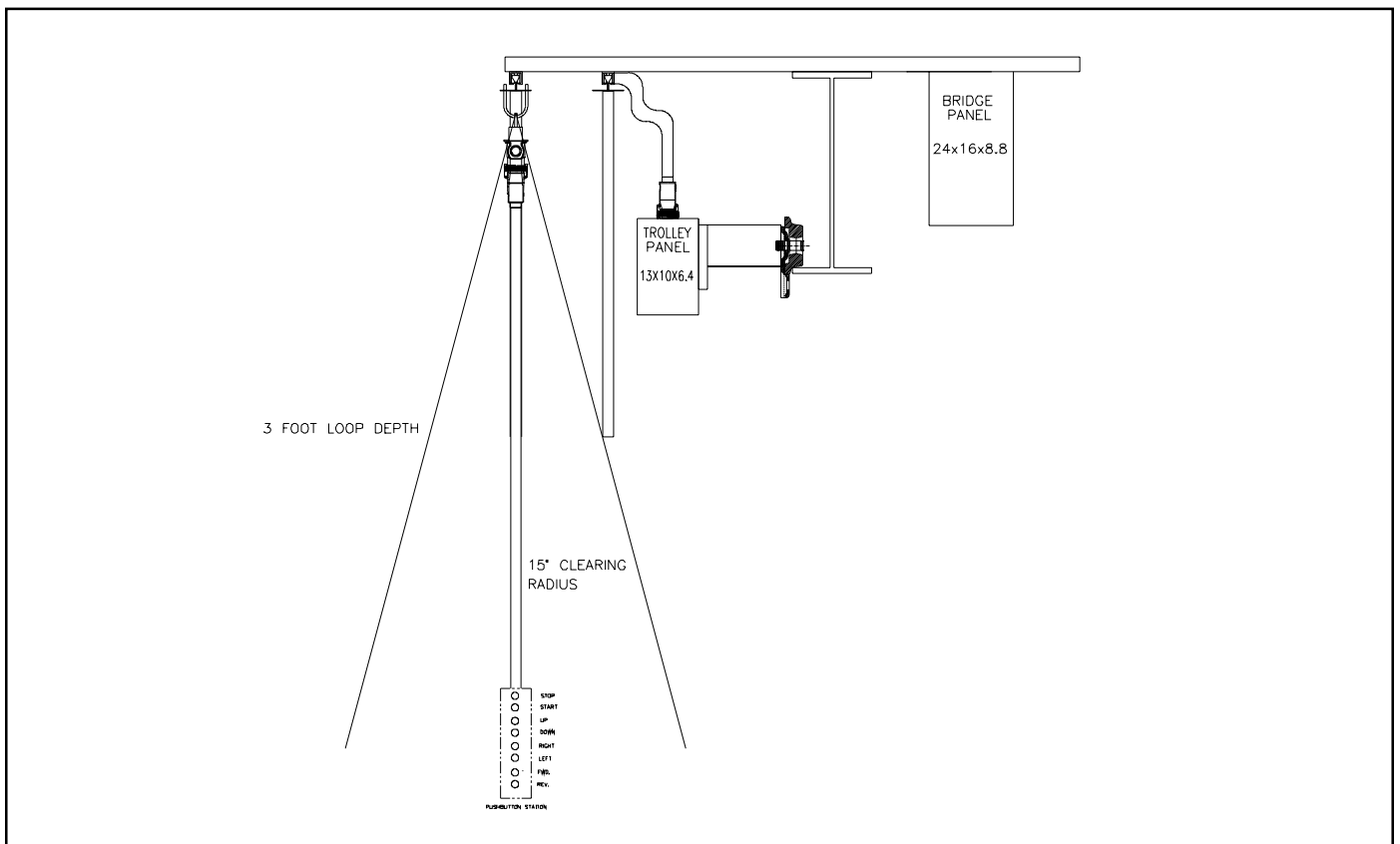
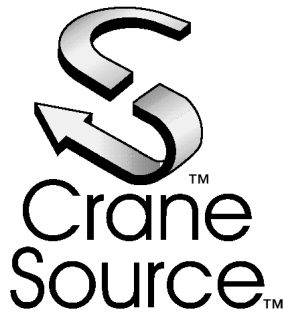

Figure C.



Lift-Tech International
414 West Broadway Avenue
P.O. Box 769
Muskegon, Michigan 49443-0769
(877) 226-6278 Phone
(800) 742-9270 Fax

WARRANTY

WARRANTY AND LIMITATION OF REMEDY AND LIABILITY

A. Seller warrants that its products and parts, when shipped, and its work (including installation, construction and start-up), when performed, will meet applicable specifications, will be of good quality and will be free from defects in material and workmanship. All claims for defective products or parts under this warranty must be made in writing immediately upon discovery and, in any event, within one (1) year from shipment of the applicable item unless Seller specifically assumes installation, construction or start-up responsibility. All claims for defective products or parts when Seller specifically assumes installation, construction or start-up responsibility, and all claims for defective work must be made in writing immediately upon discovery and, in any event, within one (1) year from completion of the applicable work by Seller, provided, however, all claims for defective products and parts must be made in writing no later than eighteen (18) months after shipment. Defective items must be held for Seller's inspection and returned to the original f.o.b. point upon request. **THE FOREGOING IS EXPRESSLY IN LIEU OF ALL OTHER WARRANTIES WHATSOEVER, EXPRESS, IMPLIED AND STATUTORY, INCLUDING, WITHOUT LIMITATION, THE IMPLIED WARRANTIES OF MERCHANTABILITY AND FITNESS.**

B. Upon Buyer's submission of a claim as provided above and its substantiation, Seller shall at its option either (i) repair or replace its product, part or work at either the original f.o.b. point of delivery or at Seller's authorized service station nearest Buyer or (ii) refund an equitable portion of the purchase price.

C. This warranty is contingent upon Buyer's proper maintenance and care of Seller's products, and does not extend to normal wear and tear. Seller reserves the right to void warranty in event of Buyer's use of inappropriate materials in the course of repair or maintenance, or if Seller's products have been dismantled prior to submission to Seller for warranty inspection.

D. The foregoing is Seller's only obligation and Buyer's exclusive remedy for breach of warranty, and is Buyer's exclusive remedy hereunder by way of breach of contract, tort, strict liability or otherwise. In no event shall Buyer be entitled to or Seller liable for incidental or consequential damages. Any action for breach of this agreement must be commenced within one (1) year after the cause of action has accrued.