



IMPORTANT SAFETY INSTRUCTIONS

Please read this manual carefully and follow its instructions. Improper use or failure to follow these instructions could result in serious injury, death or property damage. Operators should be instructed in the safe and proper use and maintenance of this product. Keep this manual for future reference.

The following safety precautions call attention to potentially dangerous conditions.

- | | |
|--|--|
| | DANGER: Immediate hazards which WILL result in severe personal injury or death. |
| | WARNING: Hazards or unsafe practices which COULD result in severe personal injury or death. |
| | CAUTION: Hazards or unsafe practices which MAY result in <i>minor</i> personal injury or product or property damage. |

NOTES: Instruct operators in the safe, proper use and maintenance. Keep this manual for future reference.

RATING

- | | |
|--|---|
| | WARNING: Failure to read, understand, and follow these instructions may result in hazards or unsafe practices COULD result in severe personal injury or death. |
| | WARNING: Lock out all electrical power before performing any service. Hazards or unsafe practices COULD result in severe personal injury or death. |
| | CAUTION: Operators need to be instructed on the safe, proper use and maintenance of this product. Keep this manual for future references. Hazards or unsafe practices MAY result in <i>minor</i> personal injury or product or property damage. |

All units are rated at 600 volts, AWG #10, Maximum.

RATINGS SPECIFICATIONS		MAXIMUM ALLOWABLE CONDUCTORS
#10 WIRE	20 AMP	3-#10 AWG Wires & 10-#14 AWG Wires
#14 WIRE	15 AMP	3-#10 AWG Wires & 12-#16 AWG Wires
#16 WIRE	5 AMP	4-#10 AWG Wires & 9-#14 AWG Wires
#8 WIRE	45 AMP	4-#10 AWG Wires & 9-#14 AWG Wires

INSTALLATION

- | | |
|--|--|
| | DANGER: To prevent electrical shock, do not install unit into live electrical circuit. Make sure power is off & locked out before starting installation. Immediate hazards WILL result in severe personal injury or death. |
|--|--|

All item and part number references must meet the following requirements: Mount unit on lower exposed portion of main shaft. Make sure unit is vertical, with shaft facing down. Make sure there is clearance around drain hole on bottom of base. In operation, either the housing or the main shaft can rotate. Should not exceed rotation speed of 10 rpm.

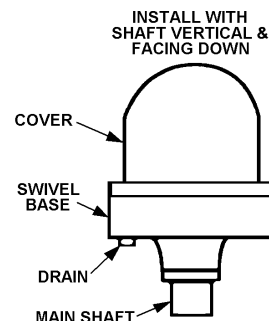

WIRING



DANGER:

To prevent electrical shock, do not install unit into live electrical circuit. Make sure power is off & locked out before starting installation. Check continuity before using unit. Also, all circuits must be fuse protected. Immediate hazards WILL result in severe personal injury or death.

For connections install watertight connectors (not supplied) with input output cables. Plug unused base swivel hole with pipe plug to seal housing. Insert input power supply through bottom of main shaft and connect to lead wires above slip ring assembly. The required number of three-part wire connectors for the input wires are supplied in a plastic bag placed inside the housing. Use all parts of the wire connector to make a secure connection. The output cable should be fed through either one of the two holes on side of base swivel.

Connect output leads to copper terminals on brush holder assemblies. Plug any unused base swivel hole to protect the internal mechanism from dirt and moisture. All models have a ground wire that connects main housing and bottom brush holder. Make sure ground wire is securely connected. For safety of equipment and personnel, all circuits must carry a fuse protection. All wiring must be completed according to diagram below.

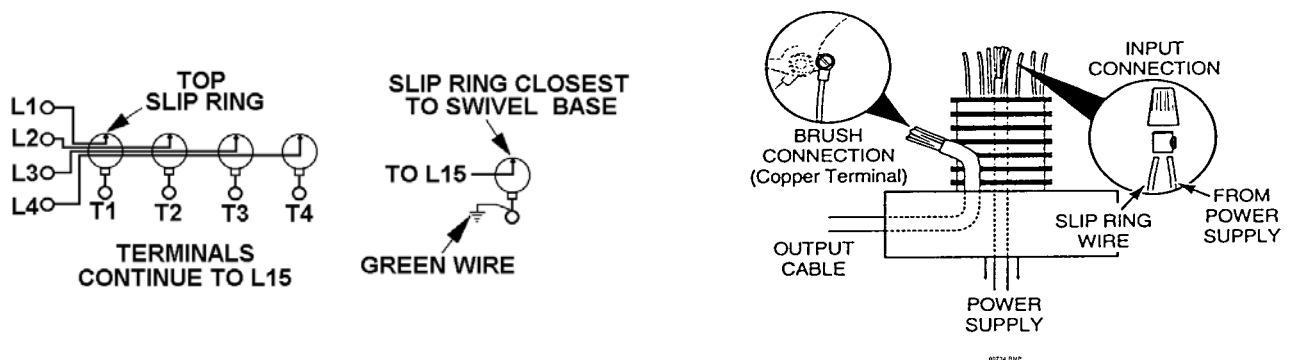

SERVICE



WARNING:

Before performing any service, always disconnect and lock out all electrical power. Unit carries 600 Volts. Hazards or unsafe practices COULD result in severe personal injury or death.

LUBRICATION

Additional shaft lubrication is possible through grease fitting in base. Applications in corrosive environments, and those with long periods without use will likely require period lubrication. A minimal amount of grease is required for full lubrication. Be careful not to over lubricate.

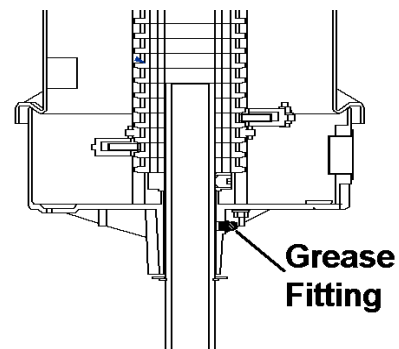

INSPECTION

Periodically inspect slip ring mechanism to verify proper mechanical alignment and electrical contact. Check condition of all parts, and replace parts that show significant wear, corrosion, or damage. Make sure when brush holder assemblies are installed that the brushes are centered between black plastic insulators and secured. Make sure brush surface makes complete contact with ring.

REPLACEMENT PARTS

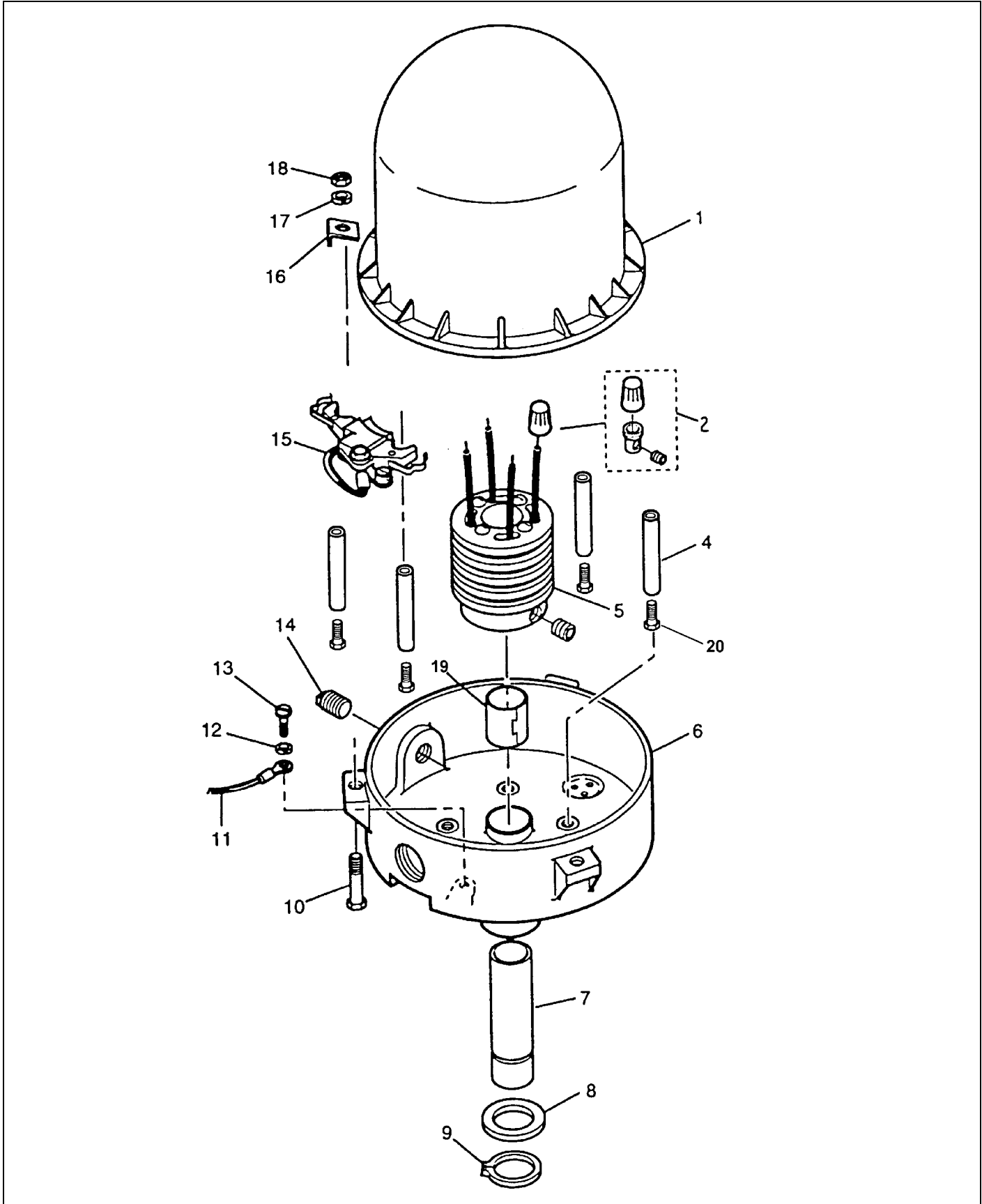

Reference Number	Part Number	Qty.	Description
1	M86520002	1	Cover
2	00900P0003	AR	Connector, 35a ISRC3xx, AR=xx (ISRC4437VM requires qty 7)
	6150400002	AR	Connector, 75a ISRC4xx, AR=xx
	C70090405	4	Connector, used only on ISRC4437VM.
4	H35460027	1	Brush Tube Kit, (includes qty 4 ref. 4 tubes and qty 4 ref. 20 screws.)
	H35460028	1	Brush Tube Kit, used only on ISRC311VM.
5	H96420XXX	1	Assembly; Slip Ring ISRC32 (XXX)=200, 33=201, 34=202, 35=203, 36=204, 37=205, 38=206, 39=207, 310=208, 311=209, 312=210, 313=211, 314=212, 315=213, 44=402, 4437=224.
6	M64160057	1	Base; Swivel
7	M35660035	1	Shaft; Main
8	5629100000	1	Ring; Thrust
9	00576P0020	1	Ring; Retaining
10	00030P0108	1	Screw; ¼-20 x 1.5, HEX. HD., Cap
11	5619600000	1	Wire; Ground, ISRC 3xx (ISRC311VM requires qty 2)
	H81310009	1	Wire; Ground, ISRC 4xx (ISRC4437VM requires qty 2)
12	00103P0025	1	Washer; #10, Lock
13	00006P0104	1	Screw; 10-20 X 3/8, Phil. Round Head
14	00825P0002	1	Plug; Pipe (½")
15	H97620007	AR	Assembly; 35A, Brush Holder (ISRC3XX) AR=XX (ISRC4437VM qty 7)
	H97620004	AR	Assembly; 75A, Brush Holder (ISRC4XX) AR=XX (ISRC4437VM qty 5)
16	6202500000	3	Cover; Clamp
17	00101P0030	3	Washer; ¼ Lock
18	00151P0020	3	Nut; ¼-20
19	C50810113	2	Bushing; Split
20	-----	4	Screw; ½-20 x ¾ HEX. WSH. HD. (Included in item 4 Kit)

<p>Aero-Motive Company W A Woodhead Industries Inc. Subsidiary PO Box 2678 Kalamazoo, MI 49003-2678 (616) 337 7700 (800) 999 8559 FAX: (800) 333 6119 www.aeromotive.com</p>	<p>AKAPP Electro Industrie W A Woodhead Industries Inc. Subsidiary Nijverheidsweg 14 Box 54 NL-3771 ME Barneveld NL-3771 AB Barneveld Holland (31) 34 241 4022 FAX: (31) 34 249 2384 www.akapp.com</p>	<p>Woodhead Connectivity LTD. W A Woodhead Industries Inc. Subsidiary Factory No. 9 Rassau Industrial Estate Ebbw Vale Gwent NP3 5SD United Kingdom (0495) 35 0436 FAX: (0495) 35 0877 sales@wdhd.co.uk</p>	<p>Woodhead Asia PTE LTD. W A Woodhead Industries Inc. Subsidiary 401 Commonwealth Drive #04-04 Haw Par Technocentre Singapore 0314 (65) 261 6533 FAX: (65) 479 3588 sales@wasia.com.sg</p>	<p>Woodhead Canada LTD. W A Woodhead Industries Inc. Subsidiary 1090 Brevik Place Mississauga Ontario L4W 3Y5 Canada (905) 624-6518 FAX: (905) 624-9151 www.woodhead.ca</p>
---	--	---	--	--