

Aero-Motive Company

W A Woodhead Industries, Inc. Subsidiary

Important Safety Instructions

Please read this manual carefully and follow its instructions. Improper use or failure to follow these instructions could result in serious injury, death or property damage. Operators should be instructed in the safe and proper use and maintenance of this product. Keep this manual for future reference.

The following safety precautions call attention to potentially dangerous conditions.



DANGER: Immediate hazards which **WILL** result in severe personal injury or death.



WARNING: Hazards or unsafe practices which **COULD** result in severe personal injury or death.



CAUTION: Hazards or unsafe practices, which **MAY** result in, *minor* personal injury or product or property damage.

INSTALLATION



WARNING: Failure to read, understand, and follow these instructions creates hazards that **COULD** result in personal injury or death.



CAUTION: Instruct operators in the safe, proper use, and maintenance of system. Keep this manual for future reference. Hazards or unsafe practices **MAY** result in *minor* personal injury or product or property damage.



WARNING: Installation should be performed by qualified electricians in accordance with the Canadian Electric Code or National Electric Code, any applicable state or local codes and any supplementary component labeling or instructions.



WARNING: Ensure power is disconnected prior to beginning any work on the system.



WARNING: Never force fingers or insert any foreign objects into conductor housing slot while the system is energized.



WARNING: Ensure power is disconnected prior to beginning any work on the system.

INSPECT COMPONENTS

Identify and inspect all systems components before installation. Make sure copper and housings are not damaged and of correct quantity. Installation of damaged product may require system disassembly to change out part.

POWER SOURCE CONNECTION

All systems use either Line Feed or End Feed box for connection to power source.

- Line Feed - Installation of feed box at any point along the housing.
- End Feed – Installation at end of system
- Multiple Feeds – Some system lengths require more than one box. Consult factory for proper installation details.

STEP #1 - MOUNTING

Sliding Hangers and Fixed-Point Clamps support housing.

- Fixed Point Clamp - Rigidly fixes housing to support structure. System expands and contracts from this point. Install adjacent to power feeding box. Line feed uses one on either side of feed box.
- Sliding Hanger – Allows housing to freely slide from fixed-point clamp as temperature changes. Install hangers every 5ft. (See diagram below).

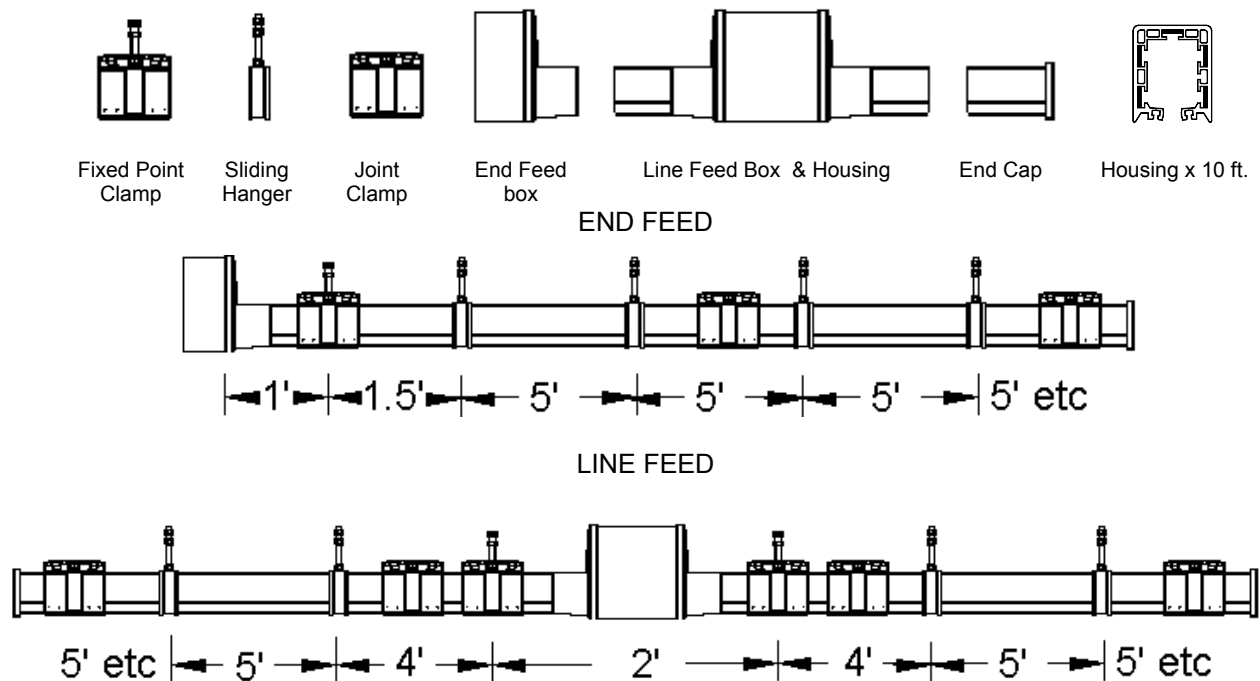

Mounting supports must have slotted holes, or other provision, for horizontal adjustment to properly align system. If purchased, Universal Support Bracket is adjustable. Make sure supports are long enough for machinery to clear housing and feed box.

Note: Horizontal sliding hanger adjustment must be provided by the mounting support (by customer).

Install all sliding hanger brackets to mounting supports. Do not tighten top two nuts of mounting support until housings are in brackets. Final alignment adjustments require housings to be in place.

Housing alignment is critical.
Hanger must not be cocked, or otherwise restrict free movement of housing through hanger.

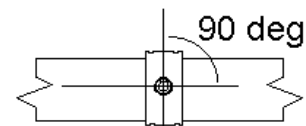

Sliding hanger comes with long bolt to allow vertical adjustment. Minimize distance between support and hanger.

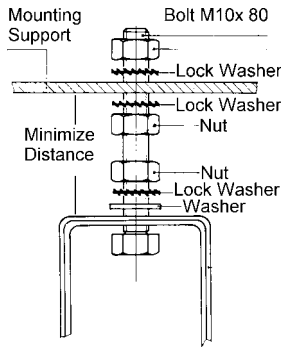

Optional Universal Support Bracket

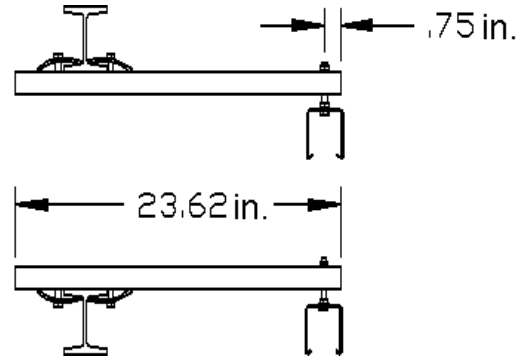

STEP #2 – SLIDE IN HOUSINGS

WARNING: Proper alignment of system is critical. All housings must butt with each other before taping and clamping. Housings must follow an absolutely parallel path to trolley tow arm. **Important:** systems up to 400 FPM must be within \pm one inch of trolley tow arm path. Systems exceeding 400 FPM must be within \pm one-half inch. Housing alignment must not rise and fall more than once in 100 feet.

Install first housing. First housing is special single 5 ft. section with slots (clamp type) 5 ft length, or two 2.5 ft sections with mating notched ends (splice type).

Install feed box plates.

Install fixed point clamp(s). Slide remaining housings into sliding hangers. All housings must have alignment stripe on same side. Align brackets as needed. All housings must meet at joints before installing tape or joint clamps. Failure to do this will require reinstallation of housings. Do not install joining pins or top plate on splice line feed. Install only after pulling copper.

IMPORTANT:

Install end collar pieces from line feed box or end feed box before mounting of housing. These parts cannot be installed later without some trouble.

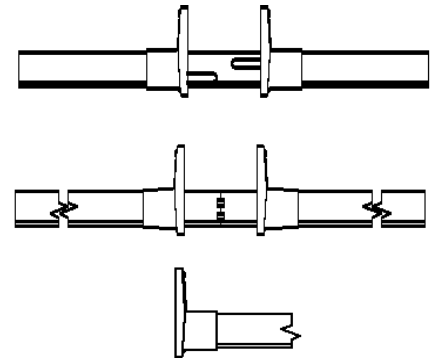

STEP #3 – TAPE AND CLAMP ALL JOINTS

Joints must be taped with AT50 insulating tape after housings and feed sections are installed. Apply tape around entire housing, including around lower lip up to sealing strip slot. Both Indoor and outdoor installations required this tape.

Hint: Tape around housing then cut opening for bottom slot.
Note: Before installing joint clamp, make sure tape goes around lower housing lip to sealing strip slot.

Exception: Some systems require expansion joints to absorb housing expansion if movement is restricted or excessive. Tape and joint clamp are not used at some, or all joints. See Alternative Mounting with Expansion Joints appendix.

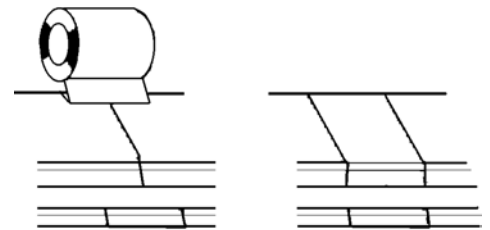

Place joint clamp halves under lip of housing and with vice grips on top fin, squeeze together, install and tighten screws. Repeat for all housings. Check that joint clamp does not compress or spread housing's opening. **Opening "A" at bottom of housing should be about .39-.59 in. for trolley to freely pass.** To fix, either squeeze clamp together, or twist a small flat piece of wood in housing, and adjust.

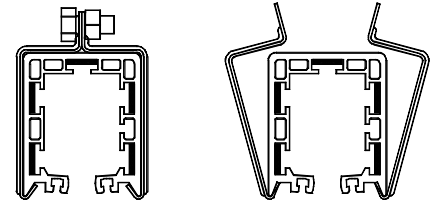

IMPORTANT: Before installing conductors check inner trolley path. Insert trolley in housing and pull by hand through entire system, checking for any restrictions to travel. This checks for housings with alignment stripes on wrong side, housings with damaged internals, and locations where bottom slot constricts trolley travel.

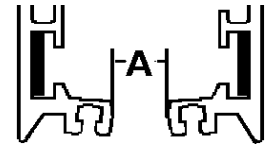

STEP #4 – PULL COPPER CONDUCTORS

CONDUCTOR INSTALLATION

First identify proper conductor locations based on number of conductors to install. For systems with multiple conductor sizes, identify each conductor size and proper location for each.

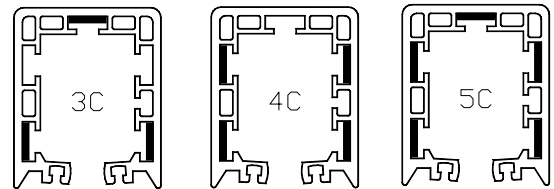

Note: Trolley can enter housing only one way so check to make sure appropriate brushes will match your intended conductor locations.

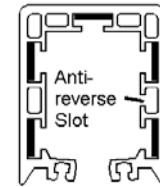

WARNING: Conductors in any other configuration will cause premature trolley wear.

Use cassette/turntable to hold conductor when pulling copper. Proper support of cassette is required; otherwise damage to conductor is possible during installation.

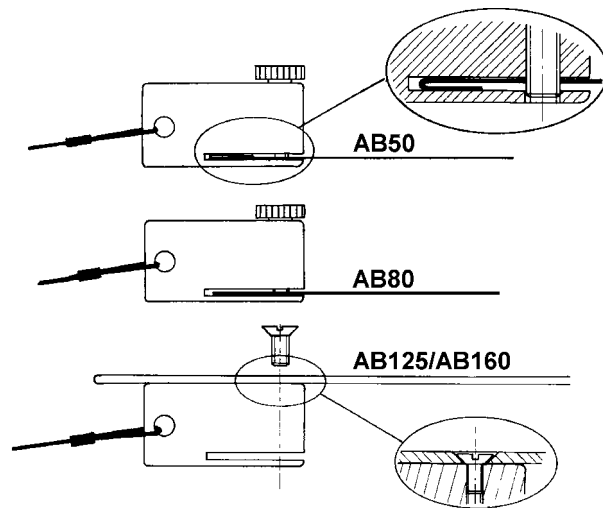

Note minimum towing angle of pulling block in picture on next page.

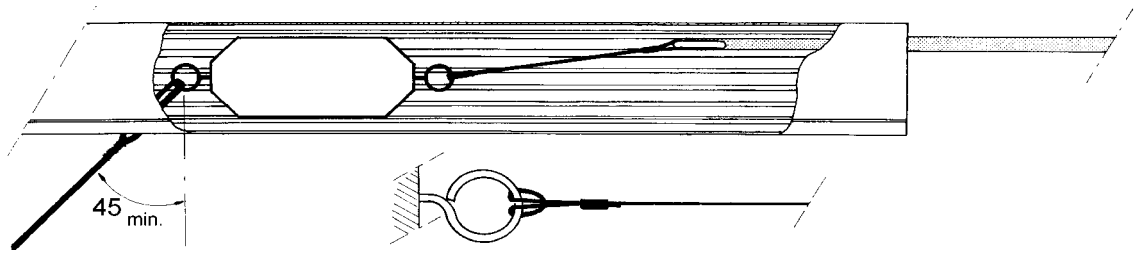

IMPORTANT: Thicker AB125 and AB160 conductors require a copper straightener. Thread copper end through straightener before attaching pulling block. Straightener takes bend out of thick copper and assures easy pulling.

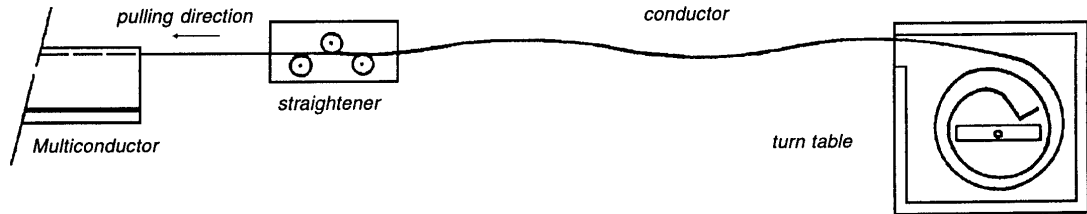

End Feed

All feed box plates must be installed prior to conductor installation. Pull conductors from end feed box end.

IMPORTANT: Copper bend at center of coil must face out at feed box end when installed. Carefully choose which side to lay copper in cassette. See pulling diagram below.

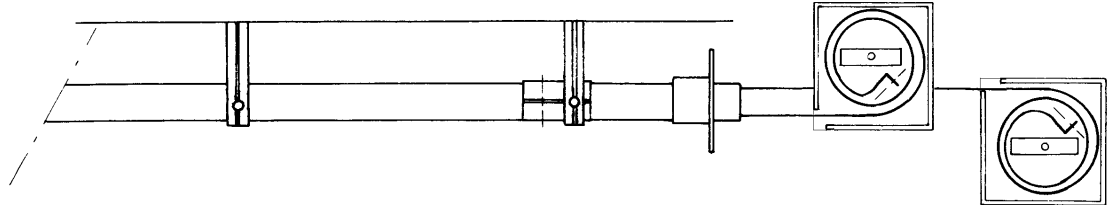
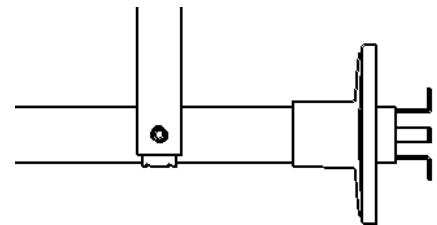

Line Feed – Clamp (Slotted Housing)

Most Line feed systems use 5 ft. line feed housing with slots and conductor clamps. Conductors may be pulled from either end of system. Position of copper bend is not critical since ends are cut to fit end caps.

Line Feed clamps at the feed box must be in position before pulling copper. They cannot be installed after copper is installed. Check to make sure copper slides through this clamp, and retains clamp before pulling copper to end.

Slotted Line Feed Housing

Install clamp before pulling conductor.

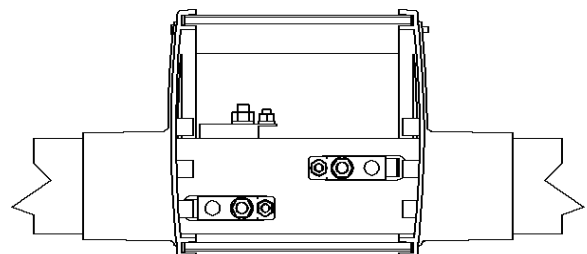
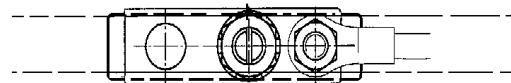

Line Feed – Splice

Some line feed systems use a splice connection. Housing is made up of two short 2.5 ft. sections with mating notched ends. Push sealing slot alignment pins completely into one housing. (After all copper is pulled and housings aligned, these pins are slid half into adjacent housing.)

Remove one fixed-point clamp and pull housing to side so you can pull conductors like end feed.

IMPORTANT: Copper bend at center of coil must face out at line feed box. Carefully choose which side to lay copper in cassette. See pulling diagram below.

File down wedges as required by copper thickness and install at joint, behind conductor, to align inside facing edges. After all conductors are installed in both directions, realign housing, attach fixed point clamp, tap alignment pins into place, install top bracket, and bolt together conductor ends.

If sealing strips are also to be used, please note that alignment pins will not allow engagement of strip. Trim back engagement edge of strip at this point (about 2 in.), and continue installing.

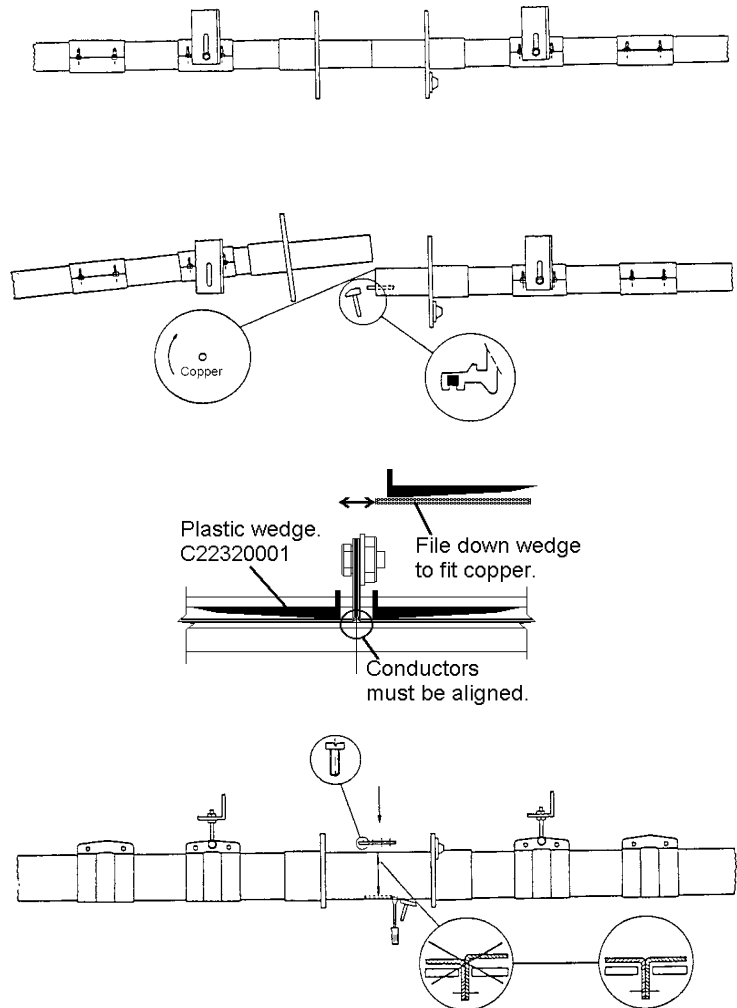

STEP #5 – MAKE REQUIRED CABLE CONNECTIONS

CONNECTING POWER SUPPLY

Connect proper power supply cable through end plate to conductor connection bolts. Drill hole in end plate as needed for conduit connection.

DO NOT OVER TIGHTEN bolts on line feed clamps. Connection screw may damage conductor and impact brush wear.

The plate for end feed box is shown. Line feed wires connect directly to clamps or conductor splice.

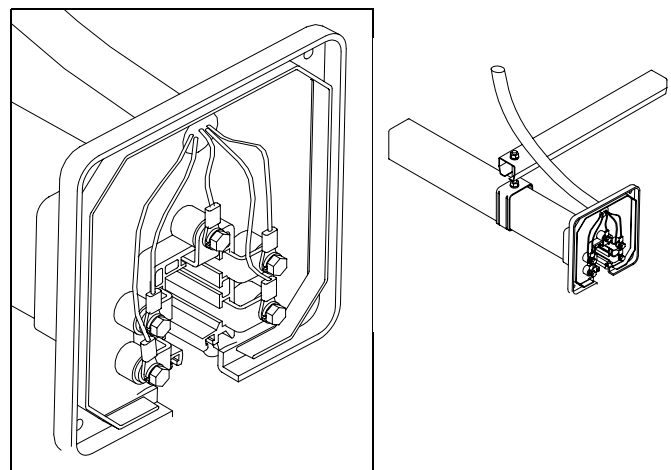

SEALING STRIPS (accessory)

If strips are dry it is necessary to use a lubricant. Wipe mineral oil, or diluted silicone- water solution (20% silicone oil /80% water) on strip while installing.

Two methods of installation.

HAND (short systems): Beginning with end of sealing strip, insert into housing slot as shown. Engage rest of strip into slot with fingers. Leave extra on end for end cap(s).

TOM THUMB (long systems): Roll out sealing strips entire length of system. Insert Tom Thumb into open housing end. Position both sealing strips into tool and pull through system. Adjust pressing feet as needed.

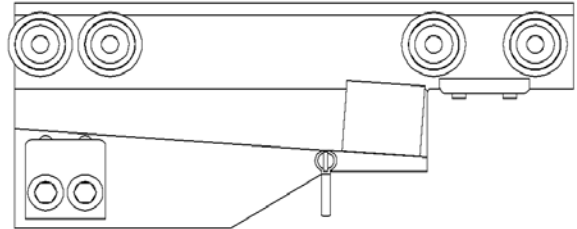
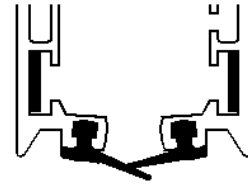

STEP #6 – INSTALL TROLLEY AND TOW ARM

INSTALLING TROLLEYS AND TOW ARMS

Each trolley can be inserted in only one direction.

Insert trolley into open end of system. Note small polarizing pilot guide on trolley that corresponds to slot in side of housing. Carefully insert by pushing in each brush until entire trolley is inside. Hand pull trolley through housing to make sure conductors are correctly installed, and joints at a line feed splice are smooth. If trolley catches on conductor joint, rework until transition is smooth.

To prolong brush life, and to resist serious trolley wear, trolley must run in-line and freely in housing.

- Cable loop must be generous, without any side pulling of trolley.
- Tow arm chain connection point must be 3/8 to 1-1/8 in. lower than trolley connection.
- Tow arm tow chains must be adjusted for minimum side pulling of trolley.

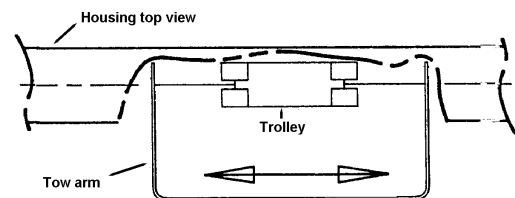
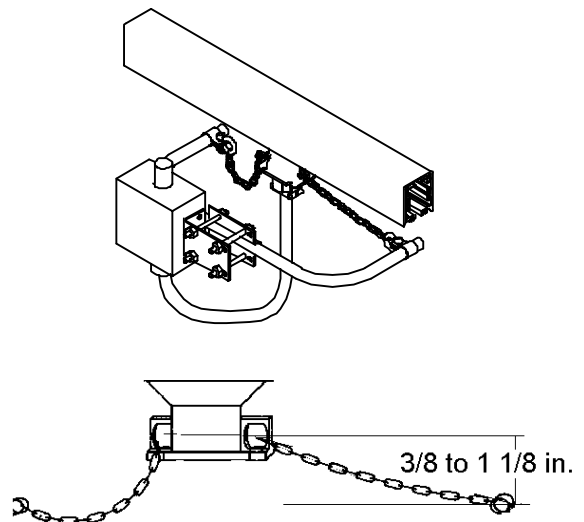

STEP #7 – INSTALL FEED BOX COVERS AND END CAP(S)

INSTALLING END OR LINE FEED COVERS

END FEED SYSTEMS – Clamp plate is required to secure end feed collar to housing. Insert clamp plate assembly and push up against feed box plate before tightening. With gasket in place, fasten box cover to end plate collar.

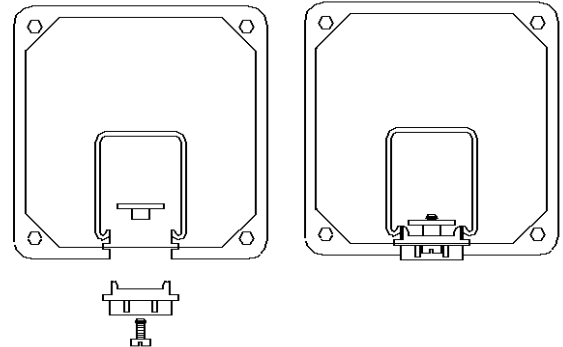

LINE FEED SYSTEMS – Insert gaskets in line feed box collar plates. Place line feed box cover between the two plates. Thread nut on one end of each threaded rod. Insert rods (with cap nut attached) into end sections, through cover and into opposite end collar plate. Align cover and securely tighten hardware.

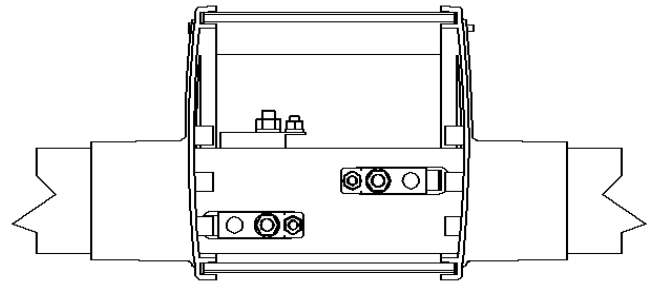

INSTALL END CAPS

Trim all protruding conductors to 2 inches from housing end. Slide end cap over conductors and into each adjacent slot. Hold to housing and install insulating tape around joint to sealing strip slot.

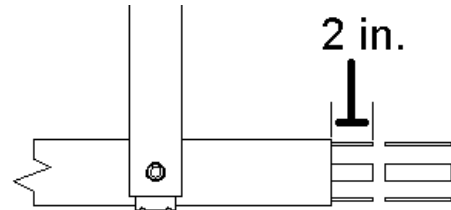

Install joint clamp and tighten all hardware.

STEP #7 – FINAL CHECK

Check These Items

- **Trolley is pulled in-line with system and cable pigtail is not affecting trolley posture.**
- **Housings are aligned within required tolerance specified in step two.**
- **No interference between feed boxes and equipment**
- **Hard ware on all sliding hangers, fixed point clamps, and feed boxes is tightened.**
- **Sliding hangers allow housing to freely slide as temperature changes.**
- **Sealing strip, if installed, is engaged with slot along total length.**
- **No squeezing or spreading of housings at joints or hangers.**

ADJUSTMENT

Trolley Alignment

Critical to proper system operation is the alignment of housing and trolley tow arm. If unusual wear is found on trolley, housings and towing may need adjustment.

INSPECTION



WARNING:

Always disconnect electrical power before dismantling any part of system. Fuse size must not be greater than maximum amperage capacity of system. Hazards or unsafe practices COULD result in severe personal injury or death.

TROLLEY

- Check brush for any unusual wear grooves.
- Check brush wear-line to edge of worn brush.
- Check wheels for tight bearings and wear.
- Check trolley neck, and body, for wear.
- Check pigtail cable for side pulling.

TOW ARM

- Check tow chains and shackles for wear.
- Check tow chain slack. Cannot be too tight. Chains must be long enough to allow for some side to side movement.
- Check tow arm mounting and alignment with track.

Brush Wear Line

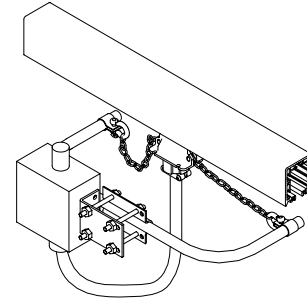
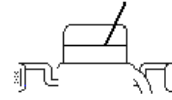

HOUSING

- Check housing joints for secure grip between adjoining housing.
- Check sliding hangers for free movement of housing. Tilted or cocked hangers must be aligned and tightened (see diagram).
- Check housing bottom slot for consistent opening. Pinching by joint clamps or sliding hangers must be corrected to .39-.59 in. width.
- Check support arms for stability. Must be horizontal and rigid.

Side View

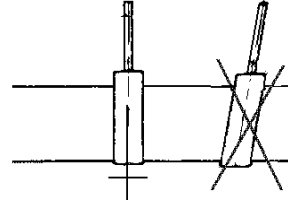

Top View

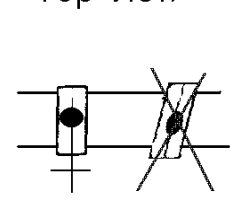

SEALING STRIP

- Check strip engagement over entire length.
- Check condition for open seams, and wear.
- Check trolley neck wear caused by sealing strip.

COPPER CONDUCTORS

- Check for smooth surface. Uneven pulling force of trolley may indicate pitting. Gently spread housing and visually inspect conductors.

MAINTENANCE

TROLLEY

Trolley brushes require changing as they approach brush wear line. Replace brush by removing retaining screw. Insert new brush, being very careful to place replacement brush over retaining spring and shunt wires into grooves. Reinsert retaining screw and tighten. Push brush back and forth to check for free movement.

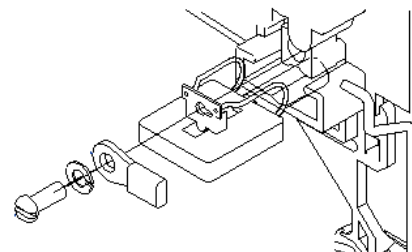

REPLACEMENT PARTS

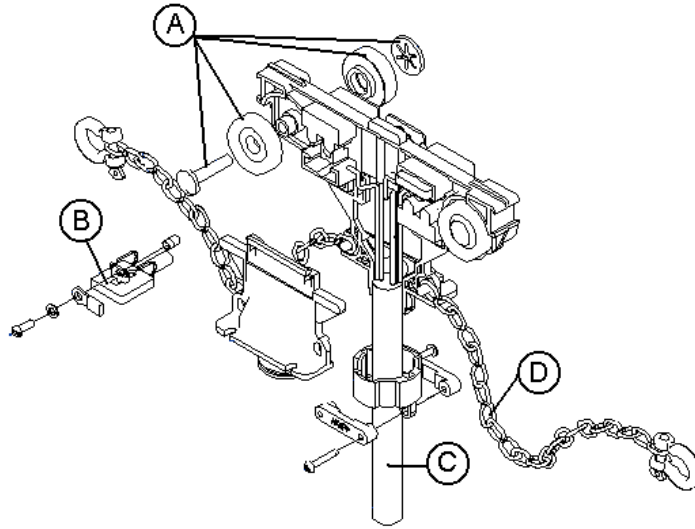

Reference	Part Number	Qty.	Description
"A"	H44600051	2	Load Wheel Kit Low Speed (2 wheels, 1 shaft , 1 retainer)
	H44600041	2	Load Wheel Kit Ball Bearing (2 wheels, 1 shaft , 1 retainer)
"B"	N7K91P	3-5	Trolley brush
"C"	R62400002	5.5 ft	5c Cable
"D"	H11610006	2	Tow Chain
Not Shown	H44600001	2	Snap on Top Wheel Assembly Low Speed
	H44600011	2	Snap on Top Wheel Assembly Ball Bearing
	H44600021	2	Snap on Top and Side Wheel Assembly Low Speed (3 wheels)
	H44600031	2	Snap on Top and Side Wheel Assembly Ball Bearing (3 wheels)
	H18110026	AR	Trolley Connector Kit (tow plate and dove-tail connection parts.
	C75540112	AR	Right Angle Connector

Aero-Motive Company

W A Woodhead Industries Inc. Subsidiary
 PO Box 2678
 Kalamazoo, MI 49003-2678
 (616) 337 7700
 (800) 999 8559
 FAX: (800) 333 6119
 www.aeromotive.com

AKAPP Electro Industrie

W A Woodhead Industries Inc. Subsidiary
 Nijverheidsweg 14 Box 54
 NL-3771 ME Barneveld
 NL-3771 AB Barneveld
 Holland
 (31) 34 241 4022
 FAX: (31) 34 249 2384
 www.akapp.com

Woodhead Connectivity LTD.

W A Woodhead Industries Inc. Subsidiary
 Factory No. 9
 Rassau Industrial Estate
 Ebbw Vale Gwent NP3 5SD
 United Kingdom
 (0495) 35 0436
 FAX: (0495) 35 0877
 sales@wdhd.co.uk

Woodhead Asia PTE LTD.

W A Woodhead Industries Inc. Subsidiary
 401 Commonwealth Drive #04-04
 Haw Par Technocentre
 Singapore 0314
 (65) 261 6533
 FAX: (65) 479 3588
 sales@wasia.com.sg

Woodhead Canada LTD.

W A Woodhead Industries Inc. Subsidiary
 1090 Brevik Place
 Mississauga Ontario
 L4W 3Y5 Canada
 (905) 624-6518
 FAX: (905) 624-9151
 www.woodhead.ca