



Aero-Motive Company

W A Woodhead Industries, Inc. Subsidiary



IMPORTANT SAFETY INSTRUCTIONS

Please read this manual carefully and follow its instructions. Improper use or failure to follow these instructions could result in serious injury, death or property damage. Operators should be instructed in the safe and proper use and maintenance of this product. Keep this manual for future reference.

The following safety precautions call attention to potentially dangerous conditions.



- | | |
|---|--|
|  | DANGER: Immediate hazards which WILL result in severe personal injury or death. |
|  | WARNING: Hazards or unsafe practices which COULD result in severe personal injury or death. |
|  | CAUTION: Hazards or unsafe practices which MAY result in <i>minor</i> personal injury or product or property damage. |

OPERATION

-  **WARNING:** Failure to read, understand, and follow instructions that lead to hazards or unsafe practices **COULD** result in severe personal injury or death.
-  **CAUTION:** Instruct operators in the safe, proper use and maintenance of this product. Keep this manual for further reference. Hazards or unsafe practices **MAY** result in *minor* personal injury or product or property damage.
-  **CAUTION:** These reels are rated at 125V, 15 AMPS maximum. Actual use must be limited to the rating of the cable installed. Hazards or unsafe practices **MAY** result in *minor* personal injury or product or property damage.

Plug male end of cable to power outlet (125V, 15 AMPS), and carry reel or cable to location where power is required.

INSTALLATION

-  **WARNING:** Always disconnect electrical power before dismantling any part of the reel. Fuse size must not be greater than maximum amperage capacity of cable. Hazards or unsafe practices **COULD** result in severe personal injury or death.
-  **CAUTION:** Check continuity before reconnecting power. Hazards or unsafe practices **MAY** result in *minor* personal injury or product or property damage.

CABLE

HW100:

Place end of lead cable through opening of drum, and out through flange opening until the desired length protrudes from the opening. Remove cable grip, and fasteners from inside drum. There are two grips supplied.

Use larger grip on No.14 and 12 awg. Use smaller grip on No. 16 awg. Lead end of cable may be coiled inside drum for storage.

NOTE: This reel may be used in the same manner for hose applicants.

HW200 & HW300:

Remove outside flange from reel by removing the three acorn nuts. Insert cable through grommet, on outside of drum, leaving enough cable inside to connect to lead wire from brush assembly. Two grips are supplied: Use larger grip on No. 14 and 12 AWG. Use smaller grip on No. 16 AWG. Install one cable grip on outside of drum to hold working cable.

WIRING

HW200 :

Strip end of cable about five inches, and strip back all leads 5/8 inch. Install terminals on end of leads, or strip back covering enough to wrap around screws of the receptacle. Attach white lead to one of the silver screws on receptacle. Attach black lead to one of the brass screws on receptacle. Secure ground (green) lead to the lead from the shunt on the inside of drum near the grommet, where the receptacle is grounded. Replace flange on drum, and secure with acorn nuts.

HW300 :

Strip end of cable about five inches, and strip back all leads 5/8 inch. Connect cable leads to brush leads following color coding: white to white, black to black, and green to ground, using the connectors provided. Place connected wires to rear of drum so that wires do not interfere with movement of slip ring assembly. Install grip outside drum to hold wire to the back of drum. Replace flange on drum and secure with the acorn nuts.

REPLACEMENT PARTS

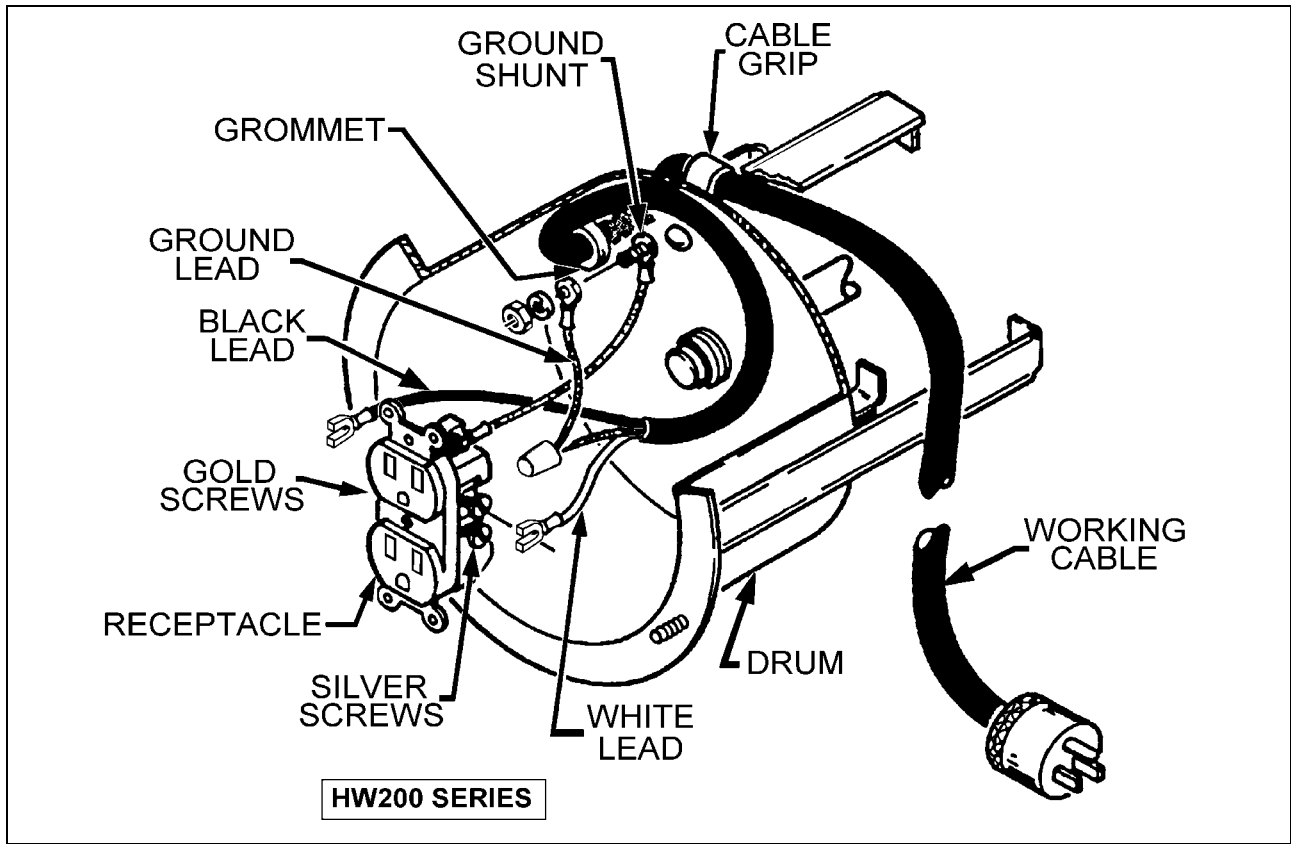
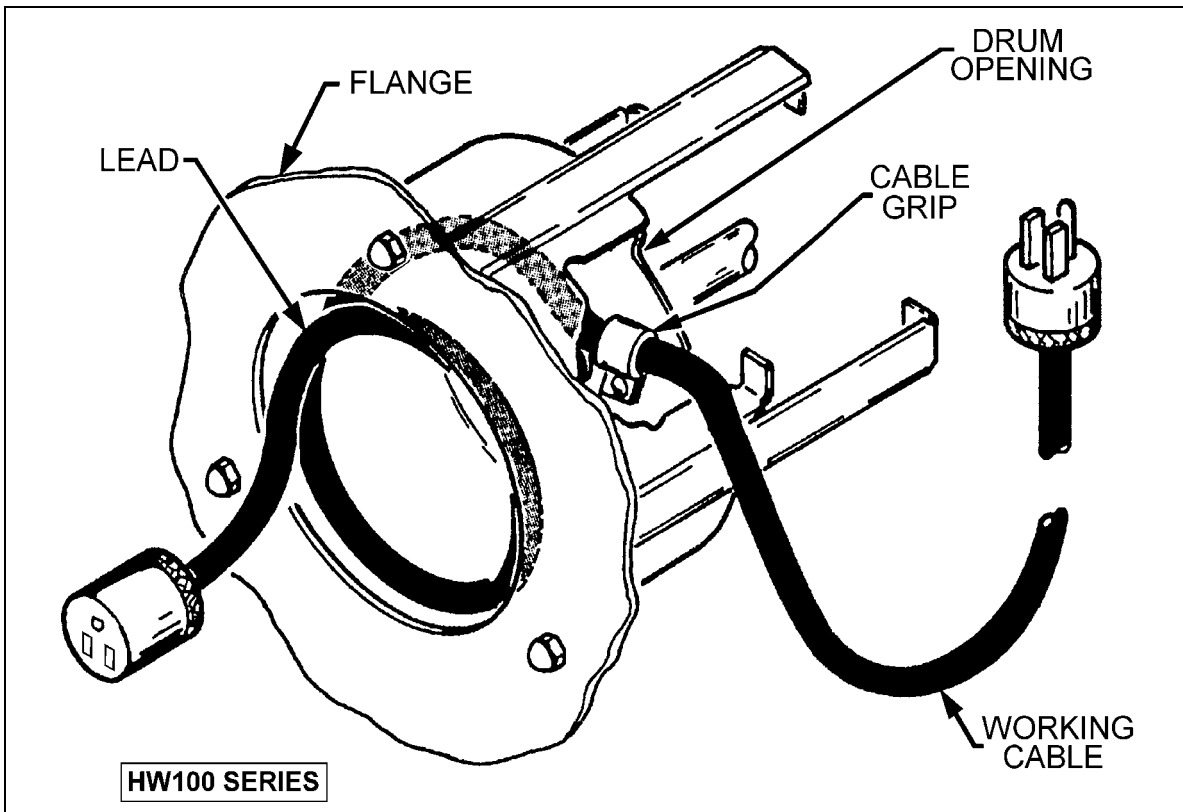

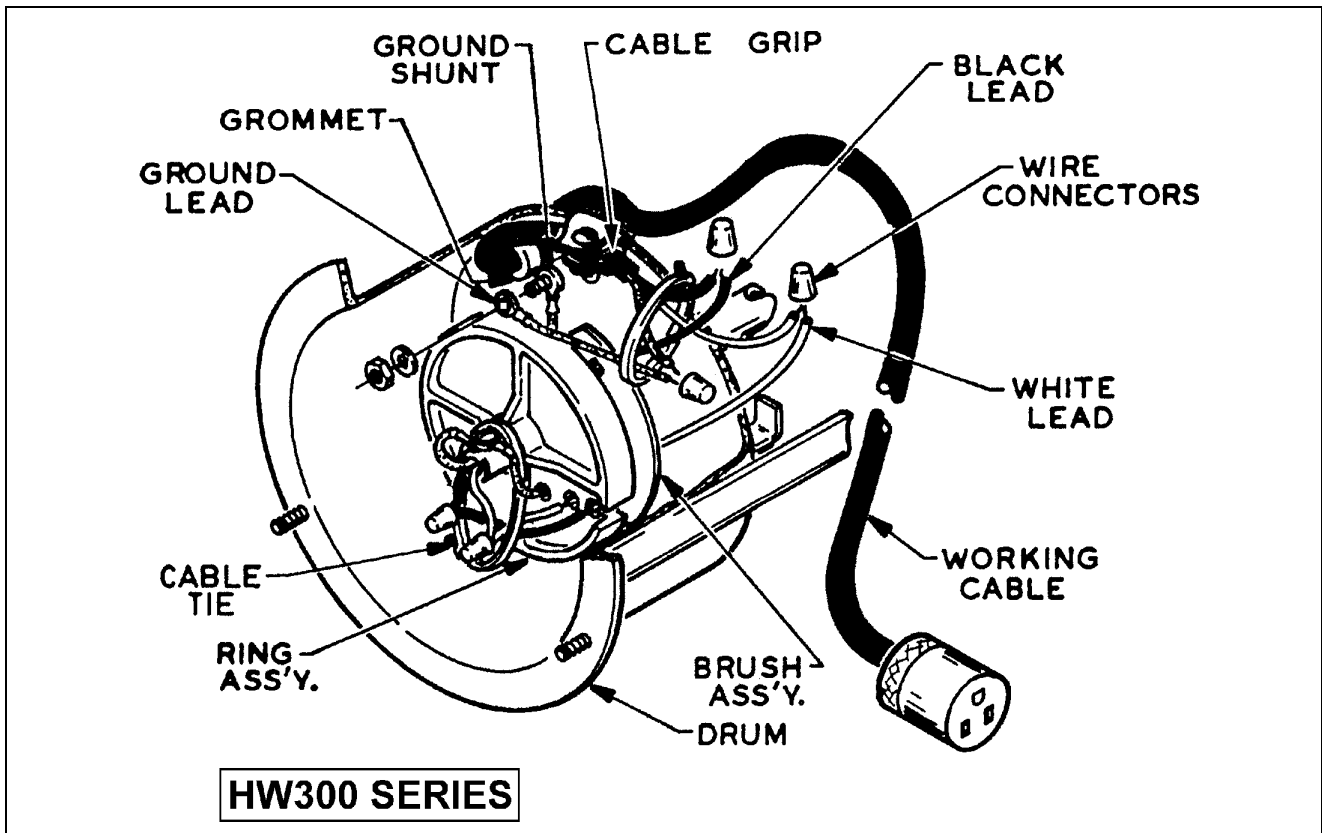

Aero-Motive Company

W A Woodhead Industries Inc. Subsidiary
 PO Box 2678
 Kalamazoo, MI 49003-2678
 (616) 337-7700
 (800)-999-8559
 FAX: (800) 333-6119

AKAPP Electro Industrie

W A Woodhead Industries Inc. Subsidiary
 Nijverheidsweg 14 Box 54
 NL-3771 ME Barneveld
 NL-3771 AB Barneveld
 Holland
 011-31-3420-14022
 FAX: 011-31-3420-92384

Aero-Motive (UK) Limited

W A Woodhead Industries Inc. Subsidiary
 Rassau Industrial Estate
 Ebbw Vale Gwent NP3 5SD
 United Kingdom
 (0495) 350436
 FAX: (0495) 350877

Woodhead Asia PTE LTD

W A Woodhead Industries Inc. Subsidiary
 401 Commonwealth Drive #04-04
 Haw Par Technocentre
 Singapore 0314
 (65) 479 6533
 FAX: (65) 479 3588

Woodhead Canada LTD.

W A Woodhead Industries Inc. Subsidiary
 1090 Brevik Place
 Mississauga Ontario
 L4W 3Y5 Canada
 (905) 624-6518
 FAX: (905) 624-9151