

Aero-Motive Company

W A Woodhead Industries, Inc. Subsidiary

Important Safety Instructions

Please read this manual carefully and follow its instructions. Improper use or failure to follow these instructions could result in serious injury, death or property damage. Operators should be instructed in the safe and proper use and maintenance of this product. Keep this manual for future reference.

The following safety precautions call attention to potentially dangerous conditions.

- ⚠ DANGER:** Immediate hazards which **WILL** result in severe personal injury or death.
- ⚠ WARNING:** Hazards or unsafe practices which **COULD** result in severe personal injury or death.
- ⚠ CAUTION:** Hazards or unsafe practices which **MAY** result in *minor* personal injury or product or property damage.

Reels are designed for use in

- Class I, Division I, Group C and D
- Class II, Division I, Group E, F, and G
- Class III Div I Outdoor

hazardous locations as defined by the National Electrical Code. All electrical connections to and from hazardous duty reels must be made in accordance with Article 500-503 of the National Electrical Code per classification of installation.

INSTALLATION

- ⚠ WARNING:** Lock out all electrical power and remove all spring tension from reel before opening any enclosure or performing any service to reel. Make sure all circuits carry appropriate fuse protection. Hazards or unsafe practices **COULD** result in severe personal injury or death.
- ⚠ WARNING:** Failure to read, understand, and follow these instructions creates hazards that **COULD** result in personal injury or death.
- ⚠ CAUTION:** Instruct operators in the safe, proper use, and maintenance of the reel. Keep this manual for future reference. Hazards or unsafe practices **MAY** result in *minor* personal injury or product or property damage.

MOUNTING

The fixed base of the reel allows mounting in several different positions including base up, base down, or wall mounted. Here are general mounting requirements:

- Main-shaft must be horizontal.
- Centerline of the spool assembly must be on line with the cable run.
- When mounted overhead in base up position, add a secondary chain, bracket or other safety device to prevent reel from falling in case the mounting bolts are removed or become loosened from vibration.

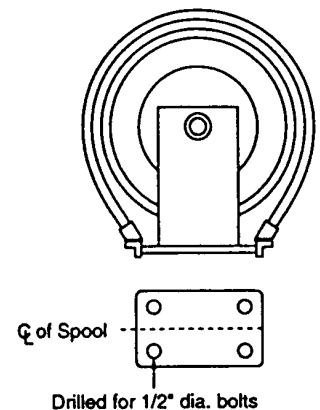

SECONDARY SUPPORT CHAIN

⚠ DANGER: A secondary safety cable or chain is to be attached to all reels mounted overhead to prevent reel from falling. Immediate hazards WILL result in severe personal injury or death.

All reels mounted over head should have a secondary support chain to protect personnel in case of structure or mounting component failure. Attach one end of secondary support chain or cable to secondary support point on reel. Attach other end of secondary support chain or cable to a support component other than that which supports the reel. The chain or cable should be as short as possible allowing reel to drop no more than 6 to 12 inches if the primary connection is released. A secondary support is offered as an accessory item.

PIVOT/SWIVEL BASE

If optional pivot /swivel base is used, reel will be self-aligning to direction of cable run. A four roller cable guide, the 2FMYE or 3FMYE must be used with pivot or swivel mounts.

GUIDE RAIL, ROLLER GUIDE, AND SHEAVES

Guide Rails – come standard with all reels. If recovery application with middle cable attachment and two-way payout, guide rails allow full freedom from side to side. There must not be a tendency for cable to pull to either side. Realign reel with payout and guide rails with reel flanges if needed.

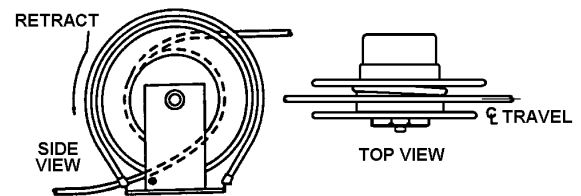

Roller Guide - used when cable is pulled out in a line tangent to drum surface. Adjust guide to minimize deflection to cable travel. This type of guide is needed for manual pull out applications using ratchet lock option. If not manual pull out, reel is often best operated without a guide. Standard guide rails assure cable will not over spool.

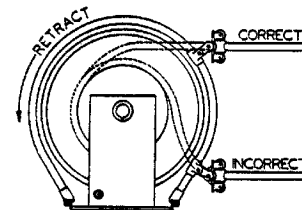

Sheaves are used to bend cable around corners. Typical minimum bend radius of the sheave should be about 7.5 x cable diameter. Requirements can vary depending on cable manufacturer specifications. Sheaves should have flat surfaces for cable to ride on. Movement of cable through a sheave should be in same plane as cable spool. Changing planes can greatly reduce cable life.

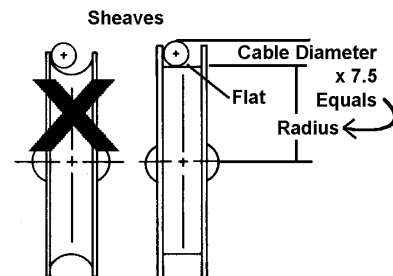

CABLE WINDING

There are many types of cable that may be installed on your cable reel depending on application. Select the cable most appropriate for your application requirements. Many cables come from factory with a wax-like film that can encourage uneven wrapping. At initial setup it is common to use a dry lubricant (talc powder), or silicone based grease to encourage more even winding. Also critical to proper winding is proper **Setup Turns**. See appropriate section. In some cases sheaves and unanticipated application features can require more tension than offered with standard reels. Contact factory for application assistance.

WIRING SUPPLY CONNECTION

Input power connection is made to hazardous location junction box through a connector or coupling which is inserted into the 1" x 1 1/2" N.P.S.C. j box pipe thread.

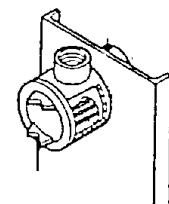

NOTE: See "Service, Working Cable Replacement/Installation" if cable needs to be installed.

OPERATION

RATCHET

When specified, reels are equipped with a ratchet lock. Tension of the motor spring holds reel against ratchet. A sharp tug on cable releases ratchet permitting reel to retract cable. Each ratchet dog is supplied with counter-weight fastened by single screw. Ratchet position and the use of the counter-weight depend upon the installed position of the reel. Here are requirements for ratchet usage:

- Wall mounting: Reel must be mounted with the ratchet side of the frame down with counter-weight attached.
- Base down mounting: Use the ratchet counter-weight.
- Base up mounting: Remove the counter-weight.

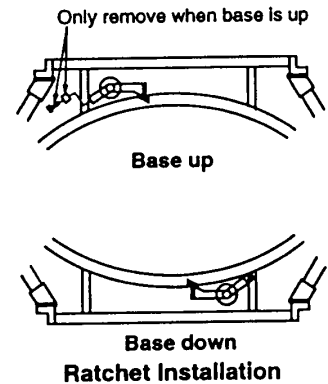

SPRING TENSION

The reels are not pretensioned. To prepare reel for use, you must apply pretensioning turns to spool assembly before connecting free end of working cable. The number of pretension turns required can vary considerably depending on application and on desired cable tension force. Set spring tension by turning fully wrapped reel through a specific number of turns. See the following guidelines on setup turns.

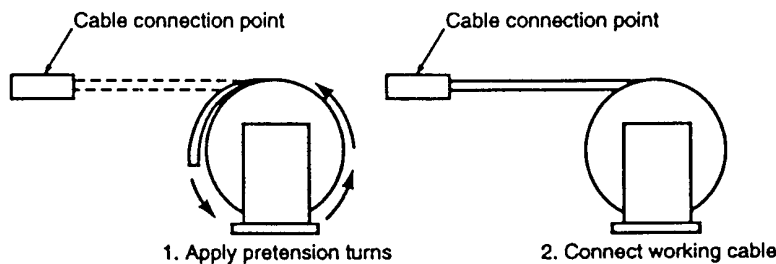

SET-UP TURNS

CAUTION: Failure to test for adequate spring revolutions can cause spring damage. Hazards or unsafe practices MAY result in *minor* personal injury or product or property damage.

Spring driven cable reels must always have setup turns applied before installing the cable free end. A minimum of 2 set up turns are to be applied per spring in the reel. **See chart below for minimum setup turn recommendation for your cable reel.**

Example: 1475-16-308 cable reel requires 10 minimum setup turns

Reel Prefix	xxxx-05-xxx	xxxx-17-xxx	xxxx-10-xxx	xxxx-16-xxx
11x2	Setup-4 / Tot-20	Setup-4 / Tot-18	Setup-4 / Tot-28	Setup-4 / Tot-24
11x3	6 / 30	6 / 27	6 / 42	6 / 36
11x4	8 / 40	8 / 36	8 / 56	8 / 42
11x5	10 / 50	10 / 45	10 / 70	10 / 54
12x3	6 / 30	6 / 27	6 / 42	6 / 36
12x5	10 / 50	10 / 45	10 / 70	10 / 54
14x3	6 / 30	6 / 27	6 / 42	6 / 36
14x5	10 / 50	10 / 45	10 / 70	10 / 54
14x6	12 / 60	12 / 54	12 / 84	12 / 72
13x4	4 / 20	4 / 18	4 / 28	4 / 24
13x6	6 / 30	6 / 27	6 / 42	6 / 36
15x4	4 / 20	4 / 18	4 / 28	4 / 24
15x6	6 / 30	6 / 27	6 / 42	6 / 36

In some instances more setup turns can be added to improve reel performance. Use following equation to find maximum allowed setup turns.

Active Turns-number of spool turns to unwrap active cable (pull off cable and count turns.)

Total Turns-see chart above

Setup -see chart above

Maximum Setup = Total Turns - ($\frac{1}{2}$ x Setup) - Active Turns

Example: 1475-16-320 cable reel using 33 Active Turns to wind cable
 $54 - (\frac{1}{2} \times 10) - 33 = 16$ maximum allowed setup

SERVICE

WARNING: Always disconnect electrical power before dismantling any part of reel. Fuse size must not be greater than maximum amperage capacity of cable. Remove all spring tension before attempting any service. Hazards or unsafe practices COULD result in severe personal injury or death.

INSTALL/REPLACE WORKING CABLE (Both new installations and for replacement of working cable.)

NOTE: Add about 10 ft. extra to active cable length (3 ft. for a dead wrap on spool and 7 ft. for slip ring connections). Also add required length for your connection at cable fixed end.

NOTE: When replacing working cable, you must also replace the seal fitting assembly (seal fitting, cover, o-ring, connector, and apply new sealing compound.

Remove slip ring cover, cable clamp from spool assembly; seal fitting cover, and cable connector. Determine length to strip outer-jacket of cable by inserting it through gooseneck fitting until reaching most distant brush terminal. Mark outer-jacket at location inside connector. Remove cable, and strip outer-jacket six inches above mark to ensure adequate conductor length to connect to brush terminals.

Pull stripped end of cable through slot in spool assembly flange adjacent to cable clamp. Insert cable through cable connector until outer-jacket becomes visible in fitting. Feed conductors through entrance ring into the collector assembly to reach their proper brush terminals. Tighten cable connector. Secure individual conductors to proper brush terminals.

Install Sealing Compound

Screw on seal fitting cover. Rotate spool so that seal fitting points down. Mix sealing compound as per manufacturer's instructions. Fill fitting with compound, being careful not to overflow into the collector ring enclosure.

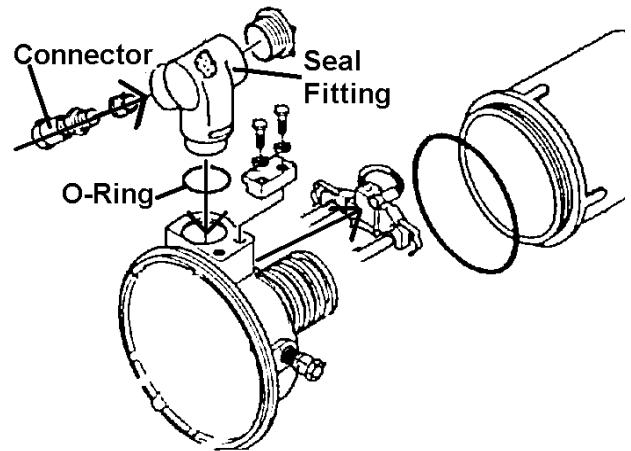

DANGER: Failure to properly install sealing compound voids hazardous location rating of reel.

Install cable clamp making sure cable is not kinked or pinched. Load working cable onto spool assembly by manually winding the reel. Count the number of turns required to fully load cable; you can use this to determine maximum setup turns.

NOTE: While winding, observe cable wrapping pattern and make sure that all twists and kinks are removed from cable. Cable twists can cause an erratic wrapping pattern and shorten cable life. Wrapping of cable will produce a clinking sound as the springs disengage from the drive hubs. This is a protective feature to prevent damage to springs. All springs will re-engage when spool is wound in opposite direction. Terminate the free end of working cable only after setup turns are applied. See section "SETUP TURNS".

COLLECTOR RING REPLACEMENT

WARNING: Disconnect and lock out all power to reel before servicing collector ring assembly. Hazards or unsafe practices **COULD** result in **severe personal injury or death**.

CAUTION: Check continuity and replace all covers before turning on electrical power. Hazards or unsafe practices **MAY** result in **minor personal injury or product or property damage**.

Remove collector ring cover. Disconnect brush holders from studs. Disconnect main shaft lead wires and remove assembly by loosening set screws and sliding collector ring off the main shaft. To reassemble, reverse the above procedure, making sure each brush is properly centered on its corresponding ring with full contact. The collector ring assembly should be snug against the entrance ring assembly.

MAIN SPRING REPLACEMENT

WARNING: To prevent personal injury, death or property damage, handle all springs with care. Use suitable protective gloves for spring handling. Hazards or unsafe practices **COULD** result in **severe personal injury or death**.

WARNING: To prevent personal injury, death or property damage, hold center of spring down as the hub is pulled out. If the center is allowed to rise up, the spring may escape from its container. Hazards or unsafe practices **COULD** result in **severe personal injury or death**. **DO NOT** remove the spring from its container.

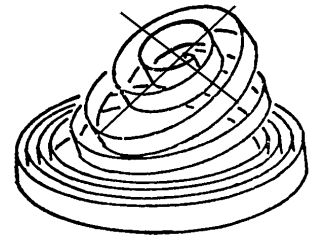

NOTE: It is recommended to replace all springs since unbroken springs of same age will likely need replacement very soon as well. Failure to do this will result in much more frequent maintenance.

It is advisable to wear gloves or other suitable hand protection since sharp edges may be encountered when handling springs. Follow same instructions as for collector ring replacement above. Remove brush holders from leads. Remove two seal fitting bolts and pull seal fitting out of entrance ring. Remove six bolts on entrance ring and pull off main shaft along with driving ring and spacer. Remove spool so spring and cup assemblies are exposed.

Each spring assembly can now be removed in their cup shaped containers. Lift each spring off main shaft being careful to disengage the hub first by rotating it in the tension reducing direction until a click is heard and hub is unhooked. Grab under each edge with your hands to help hold the spring in the pocket while lifting off and until it is safely right side up on bench. If spring is pulling out of pocket stop process and attempt to disengage.

The parallel spring 1300 and 1500 series units come with interlocking parallel spring pockets and with doublewide hubs. If the hub starts coming off with the top spring do not be alarmed. Just make sure it doesn't pull the spring out of pocket.

When disposing of old or broken spring assemblies, coils should be welded or wired together to prevent possible injury to scrap handling personnel. Replace broken spring assembly, and reassemble the springs in reverse order. When replacing spring assemblies make sure that the square projection, on the end of the spring hub below, is properly engaged in the opening of adjacent spring cup. Refer to parts drawing for part sequence and location.

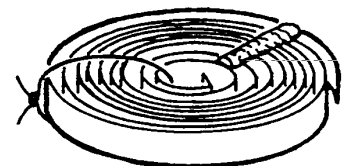

LUBRICATION

Springs and bearings have been sufficiently lubricated at the factory to last for normal life of the motor. If grease has been removed during maintenance it should be replaced with good quality high-low, temperature grease (Texaco AFB 2 or equal). Bearings should be packed, and springs should have enough grease in cup to thoroughly coat entire spring as it works in during use.

REPLACEMENT PARTS

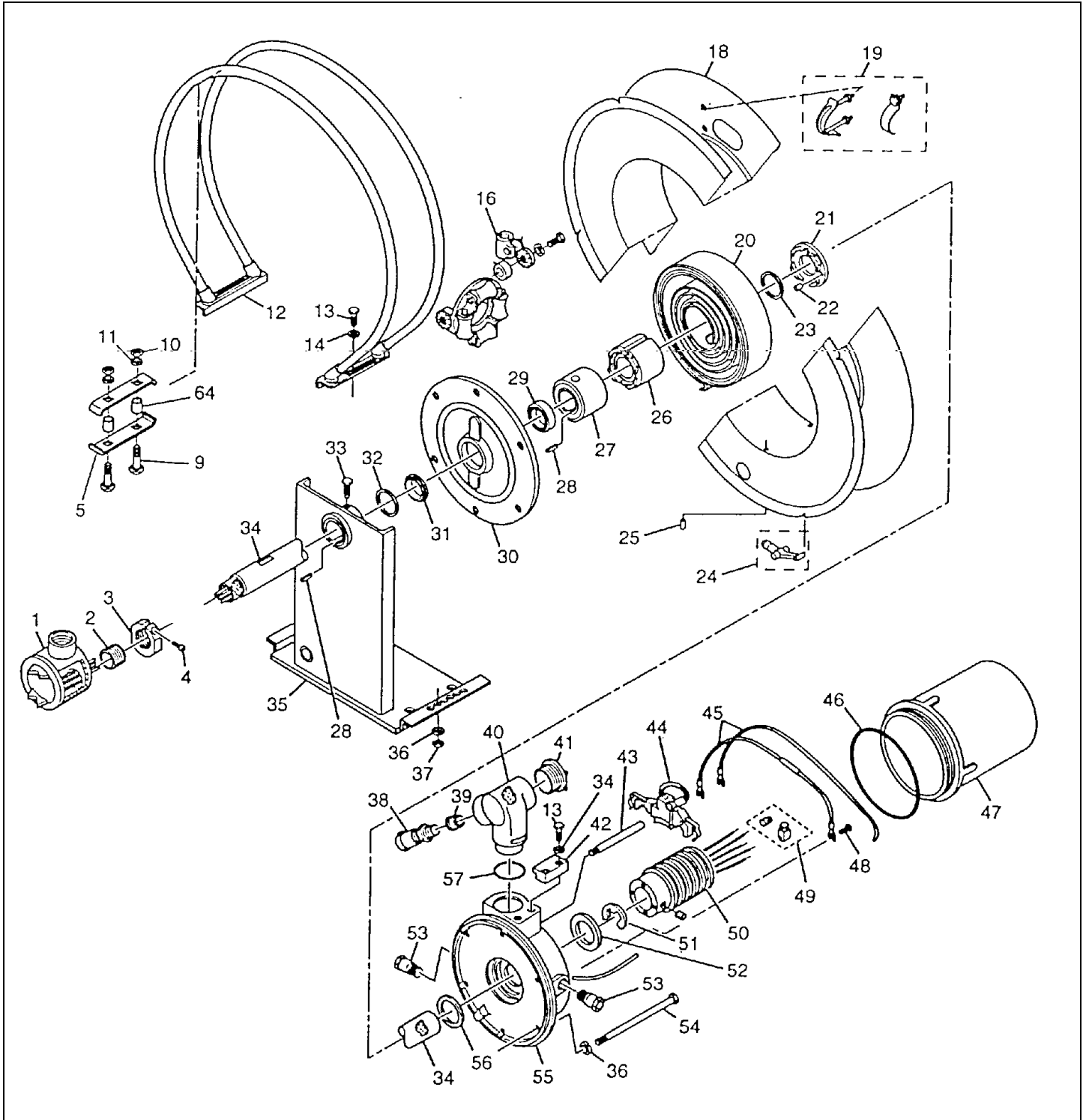

DIGITS: 1st, 2nd, 3rd, 4th, 5th, 6th, 7th, 8th, 9th, & 10th

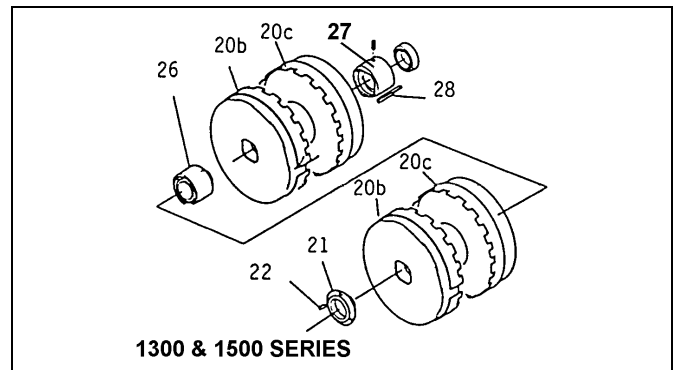
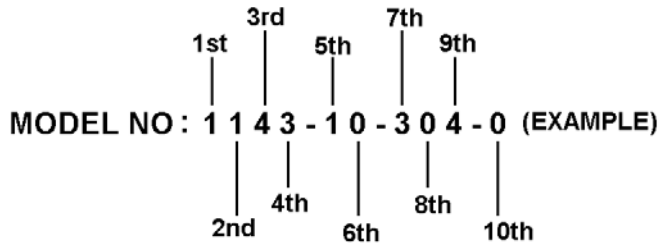

Reference Number	Part Number	Qty.	Description
1	01156P0004	1	Junction box w/cover
2	01219P0004	1	Reducer (1-1/4 to 1)
3	M70520002	1	Collar, shaft adjustable
4	C10570057	1	Screw, Soc Hd cap, M6x1x25
5	6079300000	2	Tie Bar- 3 rd Digit = (4, 6, 5) (1x4x,1x6x,1x5x)
	6079400000	2	Tie Bar (1x7x)
9	C13490015	2	Bolt, carriage M8x45
10	C22180118	2	Nut, hex head M8x1.25
11	C01190118	2	Lock washer, spring M8
12	1R	1	Assembly; Guide Rail Digits 1-4 = (11XX)
	2R	1	Assembly; Guide Rail (12XX,13XX)
	3R	1	Assembly; Guide Rail (144X,154X)
	4928500003		Assembly; Guide Rail (147X,157X)
13	C11080609	6	Screw, hex head cap, M8x50
14	C01070558	4	Flat washer, SAE, M6
16	2FMYE	A/R	Assembly; Cable Guide (2-FM)
	3FMYE	A/R	Assembly; Cable Guide (3-FM)
	2FMYE7	A/R	Assembly; Cable Guide (2-FMYE7 (IF 3 RD DIGIT =7)
	3FMYE7	A/R	Assembly; Cable Guide (3-FMYE7 (IF 3 RD DIGIT =7)
Standard or Reverse Rotation Spools No Ratchet Lock			
18	4290400019	1	Assembly; Spool Digits 1-4 = (1142) lock
	4290400003	1	Assembly Spool (xx43)
	4290400004	1	Assembly Spool (xx63)
	4290400005	1	Assembly Spool (xx64)
	4290400006	1	Assembly Spool (xx65)
	4062100005	1	Assembly Spool (xx53)
	4062100007	1	Assembly Spool (xx55)
	4062100010	1	Assembly; Spool (xx54)
	4062100011	1	Assembly Spool (xx56)
	4078300405	1	Assembly; Spool (xx43)
	4078300407	1	Assembly Spool (xx45)
	4078300408	1	Assembly Spool (xx46, xx46)
	4078300707	1	Assembly Spool (xx75)
	4078300708	1	Assembly Spool (xx76, xx76)
	4078300012	1	Assembly Spool (xx74)
Standard Rotation Spools For Ratchet Lock			
18	4290400020	1	Assembly; Spool Digits 1-4 = (1142)
	4290400009	1	Assembly Spool (1143)
	4290400010	1	Assembly Spool (1163)
	4290400011	1	Assembly Spool (1164)
	4290400012	1	Assembly Spool (1165)
	4062100001	1	Assembly Spool (1253)
	4062100002	1	Assembly Spool (1255)
	4078300001	1	Assembly; Spool (1443)
	4078300002	1	Assembly Spool (1445)

	4078300003	1	Assembly Spool (1446)
	4078300004	1	Assembly Spool (1475)
	4078300005	1	Assembly Spool (1476)
19	H16120036	1	Assembly; Clamp (.312-.499 OD)
	H16120037	1	Assembly; Clamp (.500-.624 OD)
	H16120038	1	Assembly; Clamp (.625-.749 OD)
	H16120039	1	Assembly; Clamp (.750-.984 OD)
	H16120040	1	Assembly; Clamp (.875-1.124 OD)
	H16120041	1	Assembly; Clamp (1.125-1.188 OD)
20			<u>Springs for Digits 1 & 2 = (11, 12, 14) * = 4th digit</u>
	4378200105	*	Assembly; Spring and Cup Digit 5 & 6 = (05) (Standard Rotation)
	4378200110	*	Assembly; Spring and Cup (10)
	4378200116	*	Assembly; Spring and Cup (16)
	4378200117	*	Assembly; Spring and Cup (17)
	4378200205	*	Assembly; Spring and Cup Digit 5 & 6 = (05) (Reverse Rotation)
	4378200210	*	Assembly; Spring and Cup (10)
	4378200216	*	Assembly; Spring and Cup (16)
	4378200217	*	Assembly; Spring and Cup (17)
20b			<u>Springs for Digit 1 & 2 = (13, 15) * = 4th digit</u> <u>Pocket End: Square</u>
	H41220080	*/2	Assembly; Spring and Cup Digit 5 & 6 = (05) (Standard Rotation)
	H41220082	*/2	Assembly; Spring and Cup (10)
	H41220084	*/2	Assembly; Spring and Cup (16)
	H41220086	*/2	Assembly; Spring and Cup (17)
	H41220081	*/2	Assembly; Spring and Cup Digit 5 & 6 = (05) (Reverse Rotation)
	H41220083	*/2	Assembly; Spring and Cup (10)
	H41220085	*/2	Assembly; Spring and Cup (16)
	H41220087	*/2	Assembly; Spring and Cup (17)
20c			<u>Springs for Digit 1 & 2 = (13, 15) * = 4th digit</u> <u>Pocket End: Round</u>
	H41220088	*/2	Assembly; Spring and Cup Digit 5 & 6 = (05) (Standard Rotation)
	H41220090	*/2	Assembly; Spring and Cup (10)
	H41220092	*/2	Assembly; Spring and Cup (16)
	H41220094	*/2	Assembly; Spring and Cup (17)
	H41220089	*/2	Assembly; Spring and Cup Digit 5 & 6 = (05) (Reverse Rotation)
	H41220091	*/2	Assembly; Spring and Cup (10)
	H41220093	*/2	Assembly; Spring and Cup (16)
	H41220095	*/2	Assembly; Spring and Cup (17)
21	4017600000	4	Driving ring
22	00230P0122	A/R	Drive pin (.156 diameter x .625)
23	4011900000	1	Spacer, main spring
24	11LM	A/R	Assembly; Ratchet (optional) (1100M)
	12LM	A/R	Assembly; Ratchet (optional) (1200M, 1300M)
	14LM	A/R	Assembly; Ratchet (optional) (1400M, 1500M)
25	00230P0105	2	Drive pin (.094 diameter x .375)
26	5974400001	A/R	Assembly; Rotating Spring Hub (11XX, 12XX, 14XX standard rotation)
	5974400002	A/R	Assembly; Rotating Spring Hub (11XX, 12XX, 14XX reverse rotation)
	H41650003	A/R	Assembly; Rotation Spring Hub (13XX, 15XX standard rotation)
	H41650004	A/R	Assembly; Rotation Spring Hub (13XX, 15XX reverse rotation)
27	M76420020	1	Hub; Fixed Spring (11XX, 12XX, 14XX standard rotation)
	M76470008	1	Hub; Fixed Spring (11XX, 12XX, 14XX inch fixed, reverse rotation)
	M76420021	1	Hub; Fixed Spring (13XX, 15XX standard rotation)
	M76420022	1	Hub; Fixed Spring (13XX, 15XX reverse rotation)
28	4077300002	2	Square key
29	4000500000	1	Bearing
30	M65140092	1	End plate, cable drum
31	4291900000	1	Combination spacer and bearing seal
32	4292000000	1	Seal, bearing
33	M26740127	1	Hex head screw, mounting M12x1.25
34	5628700025	A/R	Shaft; Main (Digits 7, 8, & 9 = 303, 304, 306)
	5628700026		Shaft; Main (Digits 7, 8, & 9 = 308, 310, 404)

35	H22110388	1	Stand; Weldment (Digit 1 & 2 = 11)
	H22110390	1	Stand; Weldment (12, 13)
	H22110391	1	Stand; Weldment (14, 15)
36	C01190114	12	Lock washer, spring - 1100MX - M4
	C01190114	16	Lock washer, spring - 1200MX, 1300MX, 1400MX, 1500MX
37	C22180118	4	Nut, hex M8x1.25
38	01156P0008	A/R	Connector, cable .312 - .374 OD
	01156P0009	A/R	Connector, cable .375 - .499 OD
	01156P0010	A/R	Connector, cable .500 - .624 OD
	01156P0011	A/R	Connector, cable .625 - .749 OD
	01156P0012	A/R	Connector, cable .750 - .874 OD
	01156P0013	A/R	Connector, cable .875 - .999 OD
	01156P0014	A/R	Connector, cable 1.00 - 1.188 OD
39	01219P0004	A/R	Reducer
	01219P0005	A/R	Reducer
40	M65730003	1	Seal fitting
41	C71180001	1	Seal fitting cover
42	M40460018	1	Retainer
43	M25362037	4	Stud, brush
44	6050700001	A/R	Brush holder assembly (Digits 7,8, & 9 = 303, 304, 306, 308, 310)
45	01149P0028	A/R	Lead wire, ground (7 th Digit = 3)
	01149P0031	A/R	Lead wire, ground (7 th Digit = 4)
46	C47040140	1	O-ring
47	4023900001	1	Cover, collector ring
48	C11080531	1	Hex head cap screw, ground, M5x10
49	00900P0003	A/R	Connector, wire (7 th Digit = 3)
	6150400002	A/R	Connector, wire (7 th Digit = 4)
50	H96420201	1	Collector ring assembly 3c/35amp (Digits 7, 8, & 9 = 303)
	H96420202		Collector ring assembly 4c/35amp =304
	H96420204		Collector ring assembly 6c/35amp =306
	H96420206		Collector ring assembly 8c/35amp =308
	H96420208		Collector ring assembly 10c/35amp =310
	H96420402		Collector ring assembly 4c/75amp =404
51	00580P0137	1	Retaining ring 1.500
52	5629100000	1	Thrust ring
53	C75990213	2	Drain, breather
54	M26740141	6	Tie Bolt, cable drum Digits 1-4 = (1165,1255,1445, 1475)
	M26740142	6	Tie Bolt, cable drum (1356,1446, 1476, 1546, 1576)
	M26740143	6	Tie Bolt, cable drum (1257)
	M26740134	6	Tie Bolt, cable drum (1143, 1163, 1443, 1253)
	M26740137	6	Tie Bolt, cable drum (1164, 1354, 1554, 1574)
	M26740132	6	Tie Bolt, cable drum (1142)
55	H82420006	1	Entrance ring assembly
56	C47550111	1	Gasket - dust seal
57	00700P0079	1	O-ring
63	00580P0030	A/R	Retaining ring for .375 shaft - 1200MXm 1300MX, 1400MX, 1500MX
64	6110500000	2	Spacer

Recommended spare parts –Springs 20, or 20b and 20c.

<p>Aero-Motive Company W A Woodhead Industries Inc. Subsidiary PO Box 2678 Kalamazoo, MI 49003-2678 (616) 337 7700 (800) 999 8559 FAX: (800) 333 6119 www.aeromotive.com</p>	<p>AKAPP Electro Industrie W A Woodhead Industries Inc. Subsidiary Nijverheidsweg 14 Box 54 NL-3771 ME Barneveld NL-3771 AB Barneveld Holland (31) 34 241 4022 FAX: (31) 34 249 2384 www.akapp.com</p>	<p>Woodhead Connectivity LTD. W A Woodhead Industries Inc. Subsidiary Factory No. 9 Rassau Industrial Estate Ebbw Vale Gwent NP3 5SD United Kingdom (0495) 35 0436 FAX: (0495) 35 0877 sales@wdhd.co.uk</p>	<p>Woodhead Asia PTE LTD. W A Woodhead Industries Inc. Subsidiary 401 Commonwealth Drive #04-04 Haw Par Technocentre Singapore 0314 (65) 261 6533 FAX: (65) 479 3588 sales@wasia.com.sg</p>	<p>Woodhead Canada LTD. W A Woodhead Industries Inc. Subsidiary 1090 Brevik Place Mississauga Ontario L4W 3Y5 Canada (905) 624-6518 FAX: (905) 624-9151 www.woodhead.ca</p>
---	--	---	--	--