

AERO-MOTIVE COMPANY



A Woodhead Industries, Inc. Subsidiary

IMPORTANT SAFETY INSTRUCTIONS

Please read this manual carefully and follow its instructions. Improper use or failure to follow these instructions could result in serious injury, death or property damage. Operators should be instructed in the safe and proper use and maintenance of this product. Keep this manual for future reference.

The following safety precautions call attention to potentially dangerous conditions.



DANGER: Immediate hazards which **WILL** result in severe personal injury or death.



WARNING: Hazards or unsafe practices which **COULD** result in severe personal injury or death.



CAUTION: Hazards or unsafe practices which **MAY** result in *minor* personal injury or product or property damage.

NOTE: Instruct operators in the safe, proper use and maintenance. Keep this manual for future reference.

INSTALLATION



WARNING: Failure to read, understand or follow these instructions could lead to hazards or unsafe practices **COULD** result in severe personal injury or death.



CAUTION: Instruct operators in the safe, proper use and maintenance of this product. Hazards or unsafe practices **MAY** result in *minor* personal injury or product or property damage.

MOUNTING

Hang balancer in the desired location by the clevis provided at the top. The balancer should be suspended directly over work area using an eyebolt or similar device with a break strength exceeding 6 times the combined weight of the balancer and the load it is supporting. Balancer should be mounted in such a manner as to minimize cable contact with the cable guide. For proper alignment, utilize the three mounting holes at the top of balancer. If shackle is removed to make the connections, be sure that the nut and cotter pin are properly replaced on the shackle pin.

SECONDARY SUPPORT CHAIN



DANGER: A secondary safety cable or chain is to be attached to all balancers mounted overhead to prevent balancer from falling. Immediate hazards **WILL** result in severe personal injury or death.

A hole has been provided at the side of the housing to permit installation of a secondary support chain. All balancers mounted over head should have a secondary support chain to protect personnel in case of structure or mounting component failure. Attach one end of secondary support chain or cable to secondary support point (shackle) on balancer. Attach the other end of secondary support chain or cable to a support component other than that which supports the balancer. The chain or cable should be as short as possible allowing the balancer to drop no more than 6 to 12 inches if the primary connection is released. (See Illustration) A secondary support is offered as an accessory item.

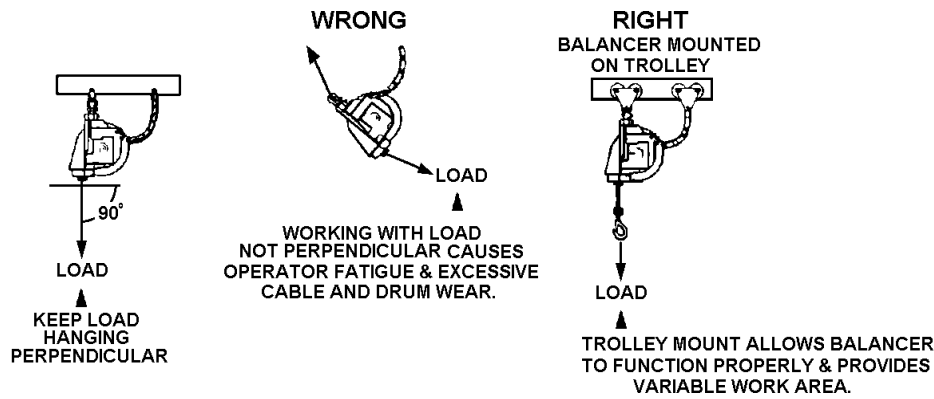

OPERATION

TOOL ATTACHMENT

WARNING: Never pull cable to device to be retracted. Always lift object to hook. If the hook is accidentally released when it is extended, it will snap back. Hazards or unsafe practices which **COULD** result in severe personal injury or death.

When attaching tool to lower hook, the tool should be lifted to hook rather than pulled to the empty hook against the reel tension. The drum lock can be engaged to prevent cable from retracting (see illustration in "Tool Replacement"). The retaining latch on lower hook **MUST** be snapped back in the closed position after tool is attached.

SPRING TENSION ADJUSTMENT

CAUTION: Only use adjusting nut to set tension. Hazards or unsafe practices **MAY** result in *minor* personal injury or product or property damage.

The complete tool including all attachments and connections must be in place before adjusting spring tension. If load exceeds spring tension, tool will move downward. If tension exceeds load, tool will move upward. Spring tension can be adjusted by turning the adjustment nut clockwise to increase tension or counterclockwise to decrease tension.

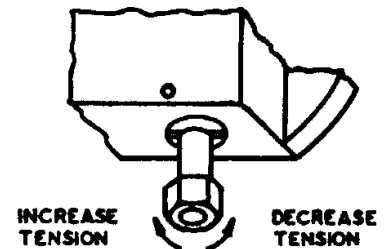

SPOT BRAKE

NOTE: See "Automatic Lock" if balancer locks up.

A spot brake is provided for fine adjustment to eliminate any "creeping" tendency. This adjustment is made only if desired and after adjustment, as explained in "Spring Tension Adjustment". To adjust, loosen lock nut and back up brake adjusting screw until the balancer works freely. Next, apply pressure to spot brake by turning adjustment screw in until desired setting is reached. Reset lock when adjustment is completed.

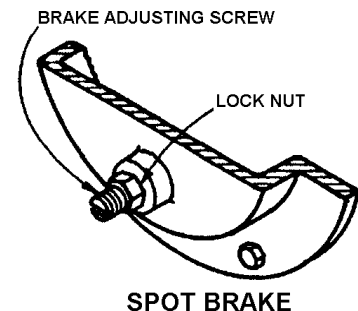

AUTOMATIC LOCK

NOTE: If tension is removed well below rated range of the balancer during spring adjustment, lock will engage. It will be necessary to apply more tension to release the lock.

If a spring should break or lose tension for any reason, an automatic lock will engage to prevent drum from turning. Lock will disengage when tension is applied to a new spring.

CABLE STOP ADJUSTMENT

Adjusting cable stop is not recommended due to reduction in active travel distance, and difficulty. If additional cable extension is required, extension cable assemblies are offered as an accessory item. In addition, special cables are available if needed.

SERVICE

TOOL REPLACEMENT

 **WARNING:** Never release drum lock unless full load is hung on balancer. If released with no load, hook will retract rapidly. Hazards or unsafe practices **COULD** result in severe personal injury or death.

Pull tool down to the most convenient height and set manual drum lock by lifting tab allowing pin to snap in (see illustration). This locks the drum in place. Tool can now be removed and replaced. After replacing tool, the drum lock can be released by pulling outward on tab and folding it back into its original position.

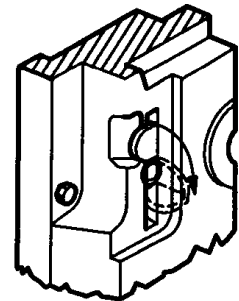

MANUAL DRUM LOCK

CABLE REPLACEMENT

 **CAUTION:** Never release drum lock unless full load is hung on the balancer. (If it is necessary to disassemble balancer to change cable, always remove all spring tension prior to disassembly (see Spring Tension Adjustment). Hazards or unsafe practices **MAY** result in *minor* personal injury or product or property damage.

Whenever cable shows signs of deterioration, it should be replaced with a new cable. To replace cable, there is no need to disassemble balancer, remove tension, and/or remove it from its location. Simply pull cable to its extreme lower limit, exposing threaded plug in the drum as shown in the illustration. Engage manual drum lock (as described in "Tool Replacement") and remove tool. Remove plug and old cable. Insert new cable and replace plug securely. Reattach tool to lower hook and disengage drum lock.

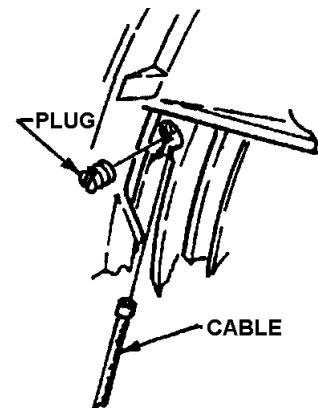

CABLE REPLACEMENT

LOWER HOOK REPLACEMENT

CAUTION: After securing clamps (or sleeve), tape may be placed around cable end to prevent injury on frayed strands. Hazards or unsafe practices MAY result in *minor* personal injury or product or property damage.

NOTE: Clamps are used for models xxxJa01 only; A swage-fitting sleeve should be used for all other models.

If lower hook is removed or replaced for any reason, the thimble and clamps (or sleeve) must be replaced as shown in illustration. If clamps are used, turn back 3 ¾ inch of rope from thimble. Apply u-bolt over dead end of wire rope - live end rests in saddle. Tighten nuts evenly, alternating from one nut to the other until reaching recommended torque (7.5 ft-lbs.). Apply second clip as near the thimble as possible. Tighten evenly, alternating until reaching recommended torque (7.5 ft-lbs.).



MAINSRING REPLACEMENT

WARNING: Never under any circumstances remove spring from its sheet metal cartridge. Replacement springs are assembled in a sealed cartridge for safety and there is no need to remove them. Removal of spring from its cartridge lead to hazards or unsafe practices which COULD result in severe personal injury or death.

CAUTION: Before removing mainspring, remove all tension from balancer by turning tension adjustment nut counterclockwise until all tension is released (ref. Spring Tension Adjustment). Hazards or unsafe practices which MAY result in *minor* personal injury or product or property damage.

Remove balancer from service. Remove the six (6) bolts and cover assembly. Now remove the four (4) bolts and pull spring assembly from drum. A new bearing is included with spring assembly. Reassemble in reverse order and readjust tension as described in Spring Tension Adjustment. To align springs with spring hub, it may be necessary to rotate spring assembly back and forth slightly as the spring assembly is pushed back onto shaft.

STAR WHEEL POSITIONING

If drum has been removed during service, it is very important to Position star wheel properly when reassembling balancer. If this is not done, drum will be "out-of- time" and will either fail to return or extend The full distance of cable travels. When reassembling, with cable off the drum and when viewed from the spring side of housing, the star wheel must be positioned as shown in relation to pin (B). The pin on the cable drum (A) must be positioned as shown in relation to point (C) on star wheel.

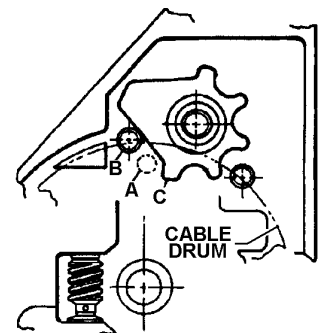

PARTS REPLACEMENT

CAUTION: Always remove all spring tension (as described in "Spring Tension Adjustment") before attempting to disassemble internal parts. Always remove balancer from service. Hazards or unsafe practices which MAY result in *minor* personal injury or product or property damage.

NOTE: When ordering replacement parts, always include the balancer model number and serial number.

All parts are replaceable in the field without special tools.

MAINTENANCE & INSPECTION

Periodic inspection of cable, lower hook, and upper swivel mount assembly (Kit A) is strongly recommended for safe operation. Bearings and guide rollers should also be inspected periodically to insure efficient operation. All bearings, springs, etc., are permanently lubricated at the factory and should require no further lubrication.

REPLACEMENT PARTS

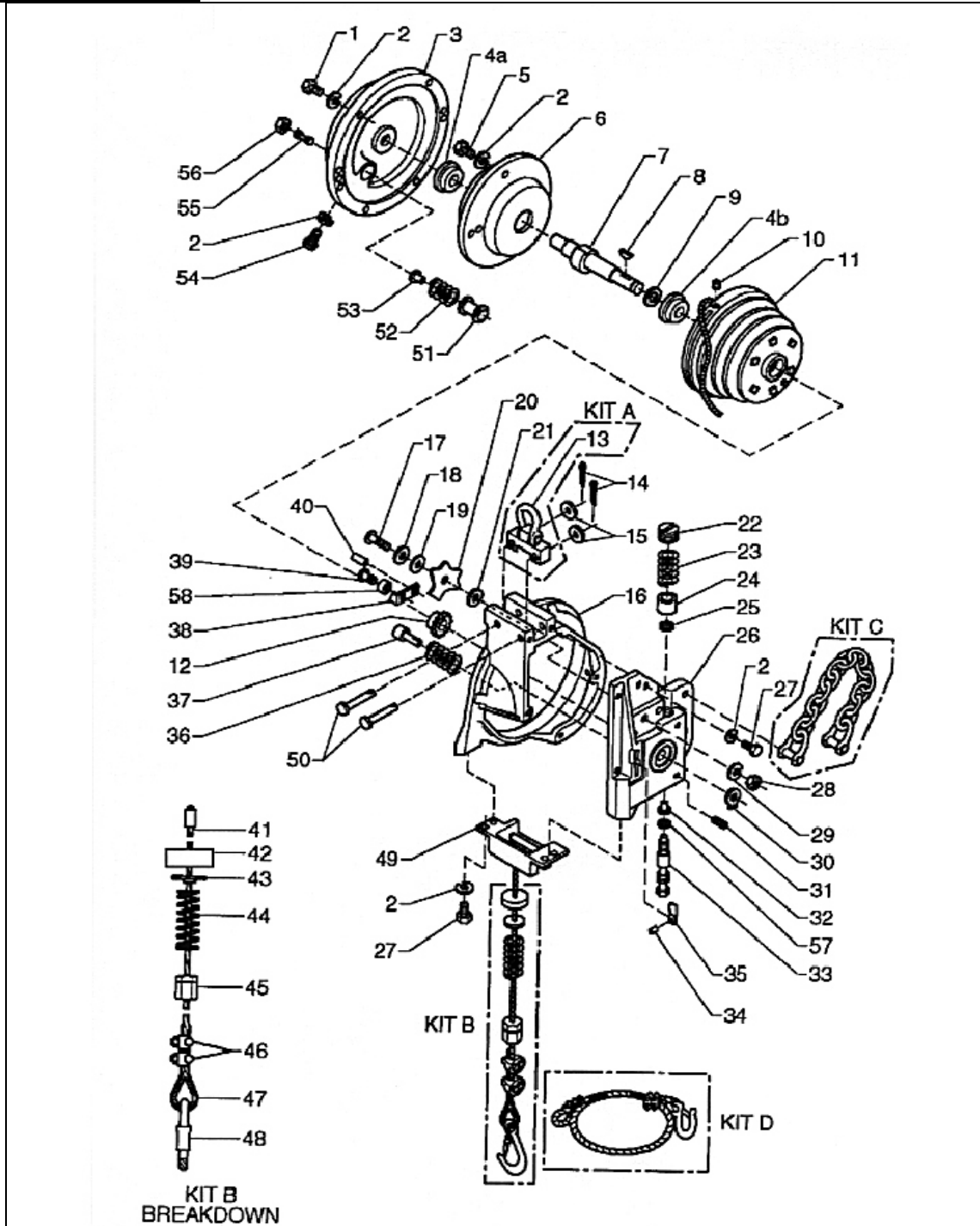

Number	Part Number	Qty.	Description
1	00030P0110	6	Screw (1/4 - 20 x 3 hex head)
2	00101P0030	20	Washer, Spring Lock (1/4)
3	3123700001	1	Cover, Main Housing
4 (a,b)	00376P0010	2	Bearing (3/4 X 1 3/4 X 5/8) -- (included with item 6)
5	00030P0115	4	Screw (1/4 - 20 x 2 3/4 Hex Head)
6	3118400020	1	Mainspring and Cup Assembly (20Ja & 9020Ja)
	3118400030	1	Mainspring and Cup Assembly (30Ja & 9030Ja)
	3118400040	1	Mainspring and Cup Assembly (40Ja & 9040Ja)
	3118400050	1	Mainspring and Cup Assembly (50Ja & 9050Ja)
	3118400060	1	Mainspring and Cup Assembly (60Ja & 9060Ja)
	3118400070	1	Mainspring and Cup Assembly (70Ja & 9070Ja)
	3118400080	1	Mainspring and Cup Assembly (80Ja)
	3118400090	1	Mainspring and Cup Assembly (90Ja)
	3118400100	1	Mainspring and Cup Assembly (100Ja)
7	6110100000	1	Shaft Assembly
8	00751P0010	1	Key, Woodruff (1/8 x 1/2)
9	00581P0070	1	Retaining Ring, Internal (1.875)
10	00826P0305	1	Pipe Plug (1/4)
11	3109100001	1	Drum Assembly 7' (20 - 100Ja)
	3109100002	1	Drum Assembly 9' (9020 - 9070Ja)
12	3105800000	1	Gear, Main Shaft Worm
13	01240P0007	1	Shackle Only (See Kit A)
14	00228P0012	2	Pin, cotter (1/8 x 1)
15	3123400000	2	Washer
16	5907500000	1	Housing
17	3107200000	1	Shaft, Star Wheel
18	3123400000	1	Washer, Star Wheel
19	3107300000	1	Spring Washer, Star Wheel
20	3107100000	1	Star Wheel 7' (20 - 100Ja)
	3129100001	1	Star Wheel 9' (9020 - 9070Ja)
21	3117100000	1	Friction Plate, Star Wheel
22	3132900000	1	Retainer, Worm Shaft Spring
23	3106700000	1	Spring, Safety Lock (20 & 9020Ja)
	C60530352	1	Spring, Safety Lock (30 - 60Ja & 9030 - 9060Ja)
	C60530351	1	Spring, Safety Lock (70 - 100Ja & 9070Ja)
24	3133000000	1	Sleeve, Worm Shaft Spring
25	3106900000	1	Seat, Safety Lock Spring
26	5907600000	1	Base Housing
27	00030P0112	1	Screw, Hex Head Cap
28	00156P0020	1	Nut, Hex Jam (SAE 1/4 - 20)
29	00101P0016	1	Lockwasher, Spring (1/2)
30	00576P0041	1	Retaining ring, external (0.750)
31	00053P0400	2	Soc. Head set screw (5/16-18x3/8)
32	3106600000	1	Bearing, worm shaft
33	4261200000	1	Worm shaft assembly
34	00229P0010	1	Drive pin (1/8x5/16)
35	3129400000	1	Lever, manual drum lock
36	3164300000	1	Spring, manual drum lock
37	3129500000	1	Shaft, manual drum lock
38	3127900000	1	Lever, safety lock
39	5952000000	1	Screw, safety lock lever
40	00230P0120	1	Drive pin (0.312x3/4)
41	H13120033	1	Cable only 7 ft. (20 - 100Ja)(see Kit B)
	H13120034	1	Cable only 9 ft (9020 - 9070Ja)(see Kit B)
42	1102600000	1	Bumper
43	3116800000	1	Retainer
44	3128500000	1	Spring
45	3162500001	1	Stop

46	00655P0010	2	Clamp (xxxJa01)
	C25380625	1	Sleeve, Swage Fitting
47	00677P0015	1	Thimble
48	3108500000	1	Hook (xxxJa, xxxJa01)
	5949700000 **	1	Bullard hook (xxxJa03)(xxxJa04)
49	5957200000	1	Cable guide assembly
50	01235P0002	2	Clevis pin
51	4260700000	1	Sleeve assembly velocity control
52	3125800000	1	Spring, velocity control friction
53	3125900000	1	Plug, velocity control friction spring
54	3125200000	1	Screw, velocity control retainer
55	00053P0509	1	Set screw, slot headless (3/8 - 24x1)
56	00156P0045	1	Hex jam nut (SAE 3/8 - 24)
57	1422700000	1	Washer - wear (3/8 inch)
58	5951900000	1	Spacer - lock lever

KITS

Kit A	4968000000	1	Upper shackle assembly (xxxJa) (xxxJa05) (xxxJa06)
	3145400000	1	Upper bullard hook assembly (xxxJa03)(xxxJa04)
Kit B	H13120029	1	Cable assembly 7 ft, complete (20 - 100Ja)
	H13120030	1	Cable assembly 9 ft, complete (9020 - 9070Ja)
	H13120031	1	Cable assembly 7 ft, w/bullard hook (20 - 100Ja03)
	H13120032	1	Cable assembly 9 ft, w/bullard hook (9020 - 9070Ja03)
	H13120018	1	Cable 7 ft, w/insulator and bullard (20 - 100Ja04) (20-100Ja05)
	H13120019	1	Cable 9 ft, w/insulator and bullard (9020 - 9070Ja04)
	4261600001	1	Cable (20-100Ja01) (20-100Ja06)
	4261600002	1	Cable (9020-9070Ja01)
Kit C	4963900000	1	Safety Chain
Kit D	4960600001	1	Overhang Cable 5'
	4960600002	1	Overhang Cable 10'
	4960600003	1	Overhang Cable 15'
	4960600004	1	Overhang Cable 20'
	4960600005	1	Overhang Cable 3'
	4960600006	1	Overhang Cable 25'
	4960600007	1	Overhang Cable 30'
	4960600008	1	Overhang Cable 35'

** Model xxxJa04 also includes the following parts

M82720001	1	Insulator
M28850024	2	Screw, Hex Head Cap, Drilled 1/2 - 13
00126P0080	2	Washer, Flat 1/2
00151P0070	2	Nut, Hex 1/2
00228P0012	2	Cotter Pin

Aero-Motive Company

AKAPP Electro Industrie

Aero-Motive (UK) Limited

Woodhead Asia PTE LTD

Woodhead Canada LTD.

W A Woodhead Industries Inc. Subsidiary
PO Box 2678
Kalamazoo, MI 49003-2678
(616) 337-7700
(800)-999-8559
FAX: (800) 333-6119

W A Woodhead Industries Inc. Subsidiary
Nijverheidsweg 14 Box 54
NL-3771 ME Barneveld
NL-3771 AB Barneveld
Holland
011-31-3420-14022
FAX: 011-31-3420-92384

W A Woodhead Industries Inc. Subsidiary
Rassau Industrial Estate
Ebbw Vale Gwent NP3 5SD
United Kingdom
(0495) 350436
FAX: (0495) 350877

W A Woodhead Industries Inc. Subsidiary
401 Commonwealth Drive #04-04
Haw Par Technocentre
Singapore 0314
(65) 479 6533
FAX: (65) 479 3588

W A Woodhead Industries Inc. Subsidiary
1090 Brevik Place
Mississauga Ontario
L4W 3Y5 Canada
(905) 624-6518
FAX: (905) 624-9151