

A BUYERS GUIDE TO

INDUSTRIAL NUT SPLITTERS



*torcup*™

Spring 2003  
[www.torcup.com](http://www.torcup.com)

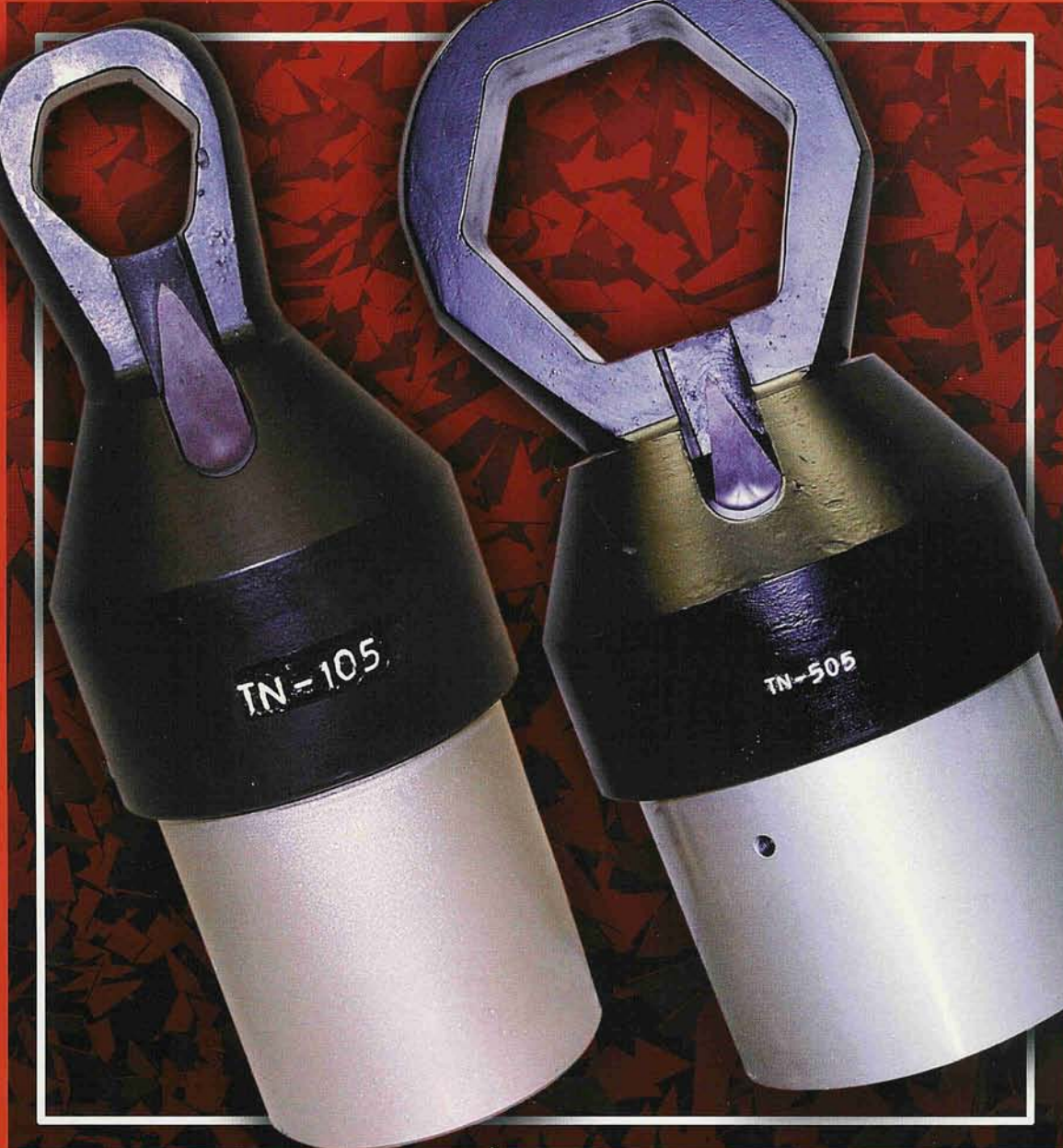



Nut Range from 1/2" through 5 3/8" (13mm through 136mm)

"SUPER-ALLOY" Cutting Chisel

Heavy Duty Forged Body Construction

TN-105

Single Acting Auto Return 10,000 PSI Power Cylinder

Quick Connect Safety Coupler

**No Nut Too Large Or Too Small...  
THE TN SERIES CUTS THEM ALL!**

# TN Nut Splitters

- **EASY** – Sets up and cuts within minutes
- **SAFE** – No sparks, no flames, no flying fragments
- **FAST** – Cuts nuts in seconds compared to hours with a torch
- **FLEXIBLE** – Tool head is designed to fit all API and ANSI flanges
- **VERSATILE** – Cuts the hardest of nuts without any damage to the stud

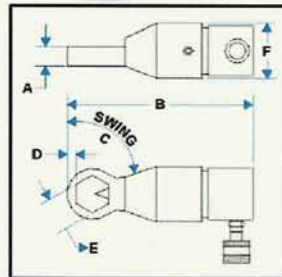

TN Nut Splitter  
(Model TN-105 to TN-505)

TN Nut Splitter  
Angle Head  
(Model TN-100)

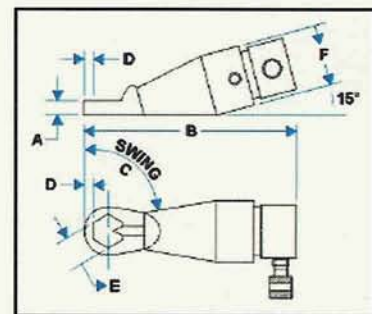

## And Most Important...

- **PRICE** – Priced competitively amongst lesser quality products
- **WARRANTY** – Covered for Six (6) months from defects in material and workmanship

Model #	A/F Range	A	B	C	D	E	F	Weight
TN-100	1/2" - 1"	11/16"	10.1/4"	30°	1/4"	1.1/16"	2.7/8"	8.20 lbs
TN-105	5/8" - 1.7/16"	1.1/2"	10.7/16"	60°	3/8"	1.1/2"	4.1/8"	21.60 lbs
TN-200	1.7/16" - 2"	1.1/2"	11.5/16"	45°	1/2"	2.1/8"	4.1/4"	22.90 lbs
TN-205	1.13/16" - 2.3/8"	2.1/4"	15.5/32"	30°	9/16"	2.1/2"	6.7/16"	71.50 lbs
TN-210	2.1/4" - 2.3/4"	2.1/4"	15.11/16"	30°	11/16"	2.7/8"	6.7/16"	72.30 lbs
TN-310	2.3/4" - 3.1/2"	3.1/16"	18.1/8"	30°	3/4"	3.7/8"	8.7/16"	158.66 lbs
TN-315	3.1/8" - 3.7/8"	3.1/8"	19.7/32"	30°	7/8"	4.1/4"	8.7/16"	163.94 lbs
TN-405	3.3/4" - 4.1/4"	3.3/4"	22.13/16"	60°	1.1/8"	4.5/8"	9.7/8"	251.20 lbs
TN-500	4.1/2" - 5"	4.1/8"	23.7/32"	60°	1.1/8"	5.3/8"	9.7/8"	256.56 lbs
TN-505	4.7/8" - 5.3/8"	4.1/8"	23.17/32"	60°	1.1/8"	5.7/8"	9.7/8"	262.90 lbs

**For Removing Corroded Fasteners... The Right Way!!**

*torcUP*™



**HP100  
Hydraulic Hand Pump**



**AP100  
Hydraulic Air Pump**



**EP100 Electric Pump**

**torcup™**

**Worldwide Supply - Worldwide Support - Worldwide Innovation**  
**For Worldwide Sales and Service Call TorcUP at 888-TORCUP-1**

1025 Conroy Place • Easton, PA • 18042 • Ph: 610-250-5800 • Fax: 610-250-2700  
E-Mail: [sales@torcup.com](mailto:sales@torcup.com) • Web: [www.torcup.com](http://www.torcup.com)