

TP03 HYDRAULIC TRASH PUMP

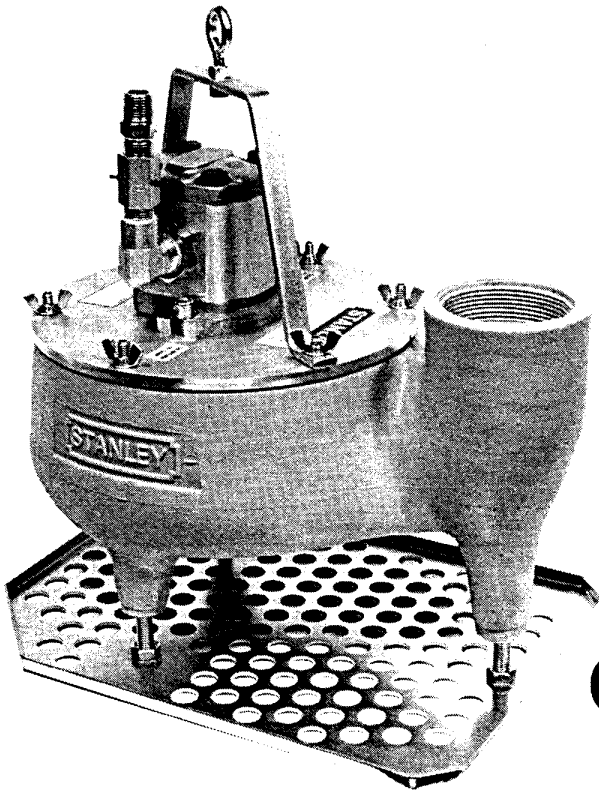

Safety, Operation and Maintenance Manual

Focused on performance™

STANLEY
helps you do things right

SAFETY PRECAUTIONS

Tool operators and maintenance personnel must always comply with the safety precautions given in this manual and on the stickers and tags attached to the tool and hose.

These safety precautions are given for your safety. Review them carefully before operating the tool and before performing maintenance or repairs.

Supervising personnel should develop additional precautions relating to the specific work area and local safety regulations. If so, place the added precautions in the space provided on page 3.

GENERAL SAFETY PRECAUTIONS

The TP03 Trash Pump will provide safe and dependable service if operated in accordance with the instructions given in this manual. Read and understand this manual and any safety stickers and tags attached to the pump and hose before operation. Failure to do so can result in personal injury or equipment damage.

- Read all safety precautions carefully before operating the tool.
- Operators must start in a work area without bystanders. The operator must be familiar with all prohibited work areas such as excessive slopes and dangerous terrain conditions.
- Establish a training program for all operators to ensure safe operation.
- Do not operate the tool unless thoroughly trained or under the supervision of an instructor.
- Always wear safety equipment such as goggles, ear protection and safety shoes at all times when operating the tool.
- Never use tools near energized transmission lines. Know the location of buried or covered services before starting work.
- Never wear loose clothing that can get entangled in the working parts of the tool.
- Do not overreach. Maintain proper footing and balance at all times.
- Do not inspect or clean the tool while the hydraulic power source is connected. Accidental engagement of the tool can cause serious injury.
- Always connect hoses to the tool hose couplers before energizing the hydraulic power source. Be sure all hose connections are tight.
- All service must be performed by authorized and properly trained personnel.

TOOL STICKERS AND TAGS

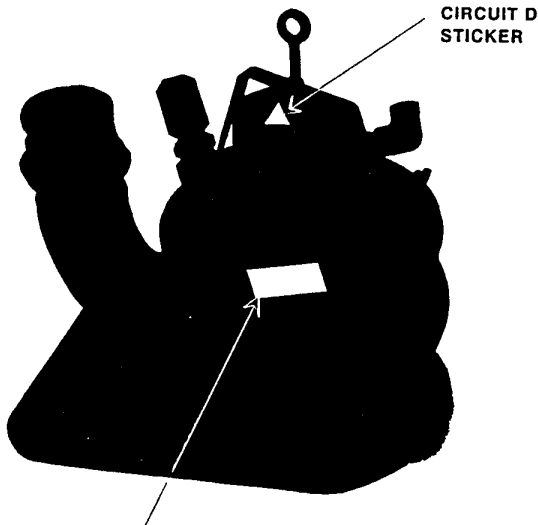

GPM/PRESSURE STICKER

A flow and pressure sticker is attached to the trash pump at the location shown. Never exceed the flow and pressure levels specified on this sticker.

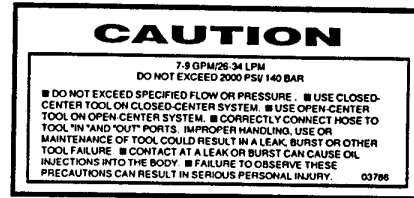

GPM/PRESSURE STICKER



CIRCUIT TYPE D STICKER

The information listed on the above sticker must be legible at all times. Always replace a worn or damaged sticker. A replacement is available from your Stanley distributor.

SAFETY TAGS

The safety tag at right is attached to the trash pump when shipped from the factory. Read and understand the safety instructions listed on this tag before removal. We suggest you retain this tag and attach it to the trash pump when not in use.

DANGER

1. FAILURE TO USE HYDRAULIC HOSE LABELED AND CERTIFIED AS NON-CONDUCTIVE WHEN USING HYDRAULIC TOOLS ON OR NEAR ELECTRICAL LINES MAY RESULT IN DEATH OR SERIOUS INJURY.
BEFORE USING HOSE LABELED AND CERTIFIED AS NON-CONDUCTIVE ON OR NEAR ELECTRICAL LINES BE SURE THE HOSE IS MAINTAINED AS NON-CONDUCTIVE. THE HOSE SHOULD BE REGULARLY TESTED FOR ELECTRIC CURRENT LEAKAGE IN ACCORDANCE WITH YOUR SAFETY DEPARTMENT INSTRUCTIONS.
2. A HYDRAULIC LEAK OR BURST MAY CAUSE OIL INJECTION INTO THE BODY OR CAUSE OTHER SEVERE PERSONAL INJURY.
 - A. DO NOT EXCEED SPECIFIED FLOW AND PRESSURE FOR THIS TOOL. EXCESS FLOW OR PRESSURE MAY CAUSE A LEAK OR BURST.
 - B. DO NOT EXCEED RATED WORKING PRESSURE OF HYDRAULIC HOSE USED WITH THIS TOOL. EXCESS PRESSURE MAY CAUSE A LEAK OR BURST.
 - C. CHECK TOOL HOSE COUPLERS AND CONNECTORS DAILY FOR LEAKS. DO NOT FEEL FOR LEAKS WITH YOUR HANDS. CONTACT WITH A LEAK MAY RESULT IN SEVERE PERSONAL INJURY.

IMPORTANT

READ OPERATION MANUAL AND SAFETY INSTRUCTIONS FOR THIS TOOL BEFORE USING IT.

USE ONLY PARTS AND REPAIR PROCEDURES APPROVED BY STANLEY AND DESCRIBED IN THE OPERATION MANUAL.

TAG TO BE REMOVED ONLY BY TOOL OPERATOR.

SEE OTHER SIDE 15875

DANGER

- D. DO NOT LIFT OR CARRY TOOL BY THE HOSES. DO NOT ABUSE HOSE. DO NOT USE KINKED, TORN OR DAMAGED HOSE.
3. MAKE SURE HYDRAULIC HOSES ARE PROPERLY CONNECTED TO THE TOOL BEFORE PRESSURIZING SYSTEM. SYSTEM PRESSURE HOSE MUST ALWAYS BE CONNECTED TO TOOL IN PORT. SYSTEM RETURN HOSE MUST ALWAYS BE CONNECTED TO TOOL OUT-PORT. REVERSING CONNECTIONS MAY CAUSE REVERSE TOOL OPERATION WHICH CAN RESULT IN SEVERE PERSONAL INJURY.
4. DO NOT CONNECT CLOSED-CENTER TOOLS TO OPEN-CENTER HYDRAULIC SYSTEMS. THIS MAY CAUSE EXTREME SYSTEM HEAT AND/OR SEVERE PERSONAL INJURY.
DO NOT CONNECT OPEN-CENTER TOOLS TO CLOSED-CENTER HYDRAULIC SYSTEMS. THIS MAY RESULT IN LOSS OF OTHER HYDRAULIC FUNCTIONS POWERED BY THE SAME SYSTEM AND/OR SEVERE PERSONAL INJURY.
5. BYSTANDERS MAY BE INJURED IN YOUR WORK AREA. KEEP BYSTANDERS CLEAR OF YOUR WORK AREA.
6. WEAR HEARING, EYE, FOOT, HAND AND HEAD PROTECTION.
7. TO AVOID PERSONAL INJURY OR EQUIPMENT DAMAGE, ALL TOOL REPAIR, MAINTENANCE AND SERVICE MUST ONLY BE PERFORMED BY AUTHORIZED AND PROPERLY TRAINED PERSONNEL.

IMPORTANT

READ OPERATION MANUAL AND SAFETY INSTRUCTIONS FOR THIS TOOL BEFORE USING IT.

USE ONLY PARTS AND REPAIR PROCEDURES APPROVED BY STANLEY AND DESCRIBED IN THE OPERATION MANUAL.

TAG TO BE REMOVED ONLY BY TOOL OPERATOR.

SEE OTHER SIDE 15875

EQUIPMENT PROTECTION AND CARE

IMPORTANT

In addition to the Safety Precautions on pages 1 thru 3 of this manual, observe the following for equipment protection and care.

- Always keep critical tool markings, such as labels and warning stickers legible.
- Tool repair should be performed by experienced personnel only.
- Make sure all couplers are wiped clean before connection.
- The hydraulic circuit control valve must be in the "OFF" position when coupling or uncoupling hydraulic tools. Failure to do so may result in damage to the quick couplers and cause overheating of the hydraulic system.
- Always store an idle pump in a clean dry space, safe from damage or pilferage.
- Always replace hoses, couplings and other parts with replacement parts recommended by Stanley Hydraulic Tools. Supply hoses must have a minimum working pressure rating of 2500 psi/175 bar.
- All hoses must have an oil-resistant inner surface and an abrasive-resistant outer surface. Whenever near electrical conductors, use clean, certified and labeled (nonmetallic braid) non-conductive hoses.
- To avoid personal injury or equipment damage, all tool repair, maintenance and service must only be performed by authorized and properly trained personnel.

HYDRAULIC HOSE REQUIREMENTS

HOSE TYPES

Hydraulic hose types authorized for use with Stanley Hydraulic Tools are as follows:

- ① Labeled and certified non-conductive
- ② Wire braided (conductive)
- ③ Fabric braided (not certified or labeled non-conductive)

Hose ① listed above is the only hose authorized for use near electrical conductors.

Hoses ② and ③ listed above are **conductive** and **must never** be used near electrical conductors.

To help ensure your safety, the following DANGER tags are attached to all hoses purchased from Stanley Hydraulic Tools. **DO NOT REMOVE THESE TAGS.**

If the information on a tag is illegible because of wear or damage, replace the tag immediately. A new tag can be obtained at no charge from your Stanley distributor.

① CERTIFIED NON-CONDUCTIVE HOSE

This tag is attached to all certified and labeled non-conductive hose.

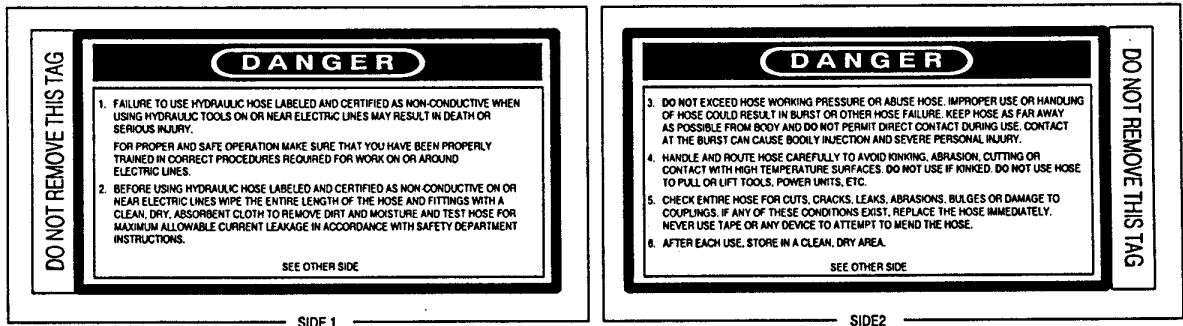

② AND ③ WIRE- AND FABRIC-BRAIDED (NOT CERTIFIED OR LABELED NON-CONDUCTIVE)

This tag is attached to all conductive hose.

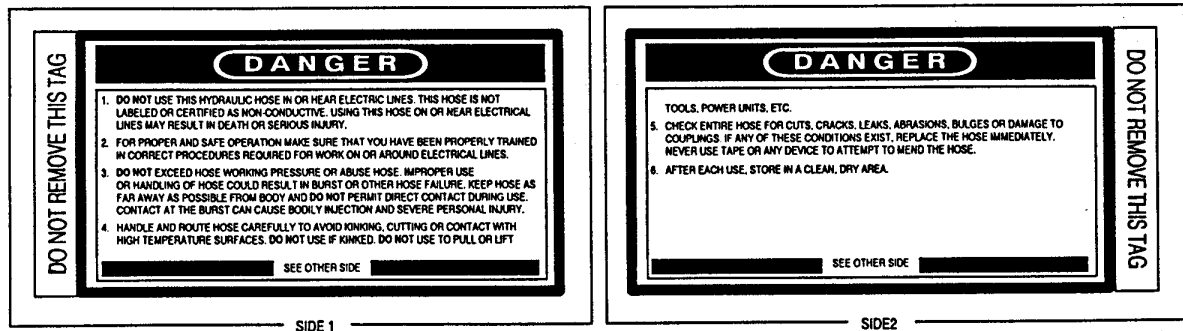

HOSE PRESSURE RATING

The rated working pressure of the hydraulic hose must be equal to or higher than the relief valve setting on the hydraulic system used to power the trash pump.

HYDRAULIC SYSTEM REQUIREMENTS

- The hydraulic system should provide a flow of 12-16 gpm/45-61 lpm at an operating pressure of 1500-2000 psi/105-140 bar. Recommended relief valve setting is 2100 psi/145 bar.
- The system should not have more than 250 psi/17 bar backpressure measured at the tool end of the operating hoses. The system conditions for measurement are at maximum fluid viscosity or 400 ssu/82 centistokes (minimum operating temperatures).
- The hydraulic system should have sufficient heat rejection capacity to limit the maximum oil temperature to 140° F/60°C difference between ambient temperature.
- The hydraulic system should have a minimum of 25 micron full-flow filtration. It is recommended that filter elements be sized for a flow of at least 30 gpm/114 lpm for cold temperature startup and maximum dirt holding capacity.
- The hydraulic fluid used should have a viscosity between 100 and 400 ssu/20 and 82 centistokes at the maximum and minimum expected operating temperatures. Petroleum base hydraulic fluid with antiwear properties and viscosity indexes over 140 will meet the recommended requirements over a wide range of operating temperatures.
- Do not use emulsifying hydraulic fluids and keep the recommended fluids drained of settled moisture. Water in the fluid can cause pump cavitation and will reduce or negate the personnel safety factor gained through the use of nonconductive hoses.
- The recommended hose sizes are listed in Table 1. Avoid the use of quick couplers to attach multiple hose lengths. To connect hoses together, use full size hose ends and pipe couplings.

Table 1. Recommended Hose Sizes

| | Pump-To-Power Source (Length-Ft.) | Inside Diameter (Minimum) |
|---------------------|----------------------------------------------|----------------------------------|
| Pressure and Return | To 50 ft/15 m | 1/2 inch/13 mm |
| Pressure and Return | 50-100 ft/15-30 m | 5/8 inch/16 mm |
| Pressure | 100-300 ft/30-90 m | 5/8 inch/16 mm |
| Return | | 3/4 inch/19 mm |

OPERATION

PREOPERATION PROCEDURES

CHECK THE POWER SOURCE

1. Using a calibrated flowmeter and pressure gauge, check that the hydraulic power source develops a flow of 7-9 gpm/26-34 lpm at 1500-2000 psi/105-140 bar.
2. Make certain the hydraulic power source is equipped with a relief valve set to crack at 2150-2250 psi/150-155 bar maximum.
3. Check that the pump inlet is clear of debris. Remove any obstructions before operating the pump. Refer to CLEANING THE PUMPING CHAMBER.

CONNECT HOSES

1. Wipe all hose couplers with a clean lint-free cloth before making connections.

IMPORTANT

Do not connect pressure to the return port. Motor shaft seal limit is 250 psi/17 bar.

2. Connect the hoses from the hydraulic power source to the couplers on the pump or pump hoses. It is a good practice to connect return hoses first and disconnect them last to minimize or avoid trapped pressure in the pump motor.

Note: If uncoupled hoses are left in the sun, heat may cause a pressure increase inside the hoses making them difficult to connect. When possible, connect the free ends of the operating hoses together.

3. If hose couplers are used, observe the arrow on the coupler to ensure that the flow is in the proper direction. The female coupler on the pump is the inlet coupler.

PUMP OPERATION

1. Observe all safety precautions.
2. Attach a 3-inch/76 mm diameter fire hose to the pump outlet. For best performance, keep the fire hose as short as possible and lay it out to avoid sharp bends or kinks.
Do not attach a nozzle to the outlet end of the fire hose. For high-pressure water pumping, use a Stanley SM20 and nozzle. The TP03 is designed for high GPM water flow at low pressure.
3. Attach a rope or cable to the lifting eye at the top of the pump. Lower the pump into the liquid to be pumped. Do not raise or lower the pump by its hoses or couplers to avoid damage to the hoses or couplers.

WARNING

Never point the hose at bystanders.

4. Turn on the hydraulic power source.
Note: It will not damage the pump to run it "DRY"
5. When pumping is completed, set the hydraulic on/off valve at the hydraulic power source to "OFF". Lift the pump from the liquid using the rope or cable.

IMPORTANT

Perform steps 6 thru 8 for pump protection and care.

6. The pump must maintain a minimum RPM and water speed to move solid particles through the pump (high speed water is required to push solids through the pump). When pumping liquids containing large solids, monitor the flow from the outlet of the fire hose. If it begins to slow, turn off the hydraulic power source and raise the pump. Disconnect the hydraulic hoses. See CLEANING THE PUMPING CHAMBER.

IMPORTANT

Pumping liquids with a solids-to-liquid ratio greater than 30% solids to 70% liquid will accelerate impeller wear.

7. To maintain performance it is good practice to periodically inspect the impeller for wear or damage. This is especially important following the pumping of liquids containing sharp, abrasive solids. See IMPELLER INSPECTION.

Note: Trash pumps with aluminum bowls are lined with rubber to protect the case from abrasion damage. The aluminum case should be returned to Stanley for relining if the liner becomes worn or torn. If liner wear is very rapid, the steel-housed TP03 should be used instead.

IMPORTANT

Do not use the aluminum-housed TP03 to pump petroleum based liquids. The rubber liner can be damaged. Use the steel-housed TP04 to pump petroleum based liquids.

8. Turn off the hydraulic powersource before raising the pump. Raise the pump by the rope or cable attached to its top to avoid damaging the hoses and couplings.

COLD WEATHER OPERATION

If the pump is to be used during cold weather, preheat the hydraulic fluid at low engine speed. When using the normally recommended fluids, fluid should be at or above 50°F/10°C (400 ssu/ 82 centistokes) before use.

Damage to the hydraulic system or pump motor could result from using fluid that is too viscous or thick.

CLEANING THE PUMPING CHAMBER

1. Remove the six 3/8-16 wing nuts securing the motor adapter plate and motor to the case.
2. Clear the debris and determine whether or not the fire hose is clogged or the power source is not providing adequate flow/pressure to properly drive the pump. If the pump is not cleared, heavy solids will not be removed from the pump, eventually damaging or destroying the impeller.
3. Place the motor adapter plate over the case studs
4. Install the handle and lifting eye on the motor adapter plate and secure with six 3/8-16 wing nuts. Tighten by hand only.
5. Install the hoses and couplers.

Note: A slot has been milled in the underside of aluminum motor adapter plate near the pump outlet. This slot allows air near the impeller to be submerged and prevents binding.

Inspect this slot before each use to ensure that no obstruction blocks this vent slot.

It is normal for a small amount of water to squirt from this slot while pumping.

SERVICE INSTRUCTIONS

Good maintenance practices will keep the pump on the job and increase its service life.

The single-most important maintenance practice is to keep the hydraulic oil clean at all times. Contaminated hydraulic oil will cause rapid wear and/or failure of motor internal parts.

Follow the procedures contained in the "HYDRAULIC SYSTEMS REQUIREMENTS" section of this manual to ensure peak performance from the tool.

Disassemble the motor only to the extent necessary to replace the shaft seal. Disassembly of the pump should be limited to the extent specified in PUMP DISASSEMBLY procedures.

If troubleshooting procedures isolates a defective part, disassemble the pump only to the extent required to replace the part.

KEEP CONTAMINANTS SUCH AS DIRT AND GRIT AWAY FROM THE HYDRAULIC SYSTEM AT ALL TIMES.

Always determine and correct the cause of the problem prior to reassembly. Further wear and tool failure can result if the original cause is not corrected.

PUMP DISASSEMBLY

1. Remove hoses and/or couplers from the motor.
2. Remove six 3/8-16 wing nuts and set aside the handle with lifting eye attached.
3. Lift the motor adapter plate from the case.
4. To remove the impeller, remove the motor shaft capscrew, lockwasher and flatwasher. Support the impeller and tap the motor shaft with a plastic mallet.

On units with a polyurethane casing, the impeller is held in place by a capscrew, lockwasher and flatwasher.

5. Remove two 3/8-16 locknuts and two 3/8-16 x 1-1/4 inch/32 mm flat head screws securing the motor to the motor adapter plate.

MOTOR SHAFT SEAL REPLACEMENT

1. Obtain seal kit (Part Number 23567) **before** proceeding. The motor shaft seal can be replaced without disassembly of the motor.
 2. Secure the motor in a vise, shaft end up.
 3. Remove the retaining ring.
 4. Plug the "IN" port of the motor and connect the "OUT" port to a hydraulic power source. This will pressurize the motor in a reverse direction, forcing out the shaft seal.
 5. Cover the motor shaft with a cloth or cardboard box to control the oil spray. Turn on the hydraulic power source. By blocking the "IN" port, sufficient pressure will be generated to force out the motor shaft seal without damage to other parts of the motor.
- Note:** When the motor shaft seal comes out, be prepared to quickly turn off the hydraulic power source.
6. Remove the plug from the "IN" port.
 7. Assemble the new seal parts on the motor shaft in the following order: Flatwasher, seal (open side toward motor), seal gland with o-ring (o-ring side toward motor). Take care not to damage the seal or o-ring.
 8. Secure with the retaining ring.

PUMP ASSEMBLY

1. Install the motor on the motor adapter plate with two 3/8-16 x 1-1/4 inch/32 mm long flat head screws and 3/8-16 locknuts.
2. Coat the motor shaft with waterproof grease, then install on the impeller.

3. Install the key on the motor shaft. Secure the impeller with the flatwasher, lockwasher and capnut.

On units with a polyurethane casing, the impeller is held in place by a capscrew, lockwasher and flatwasher.

4. Install the gasket over the case studs (steel cased pumps only). **DO NOT USE GASKET SEALER.**

5. Place the motor adapter plate over the case studs

6. Install the handle and lifting eye on the motor adapter plate and secure with six 3/8-16 wing nuts. Hand-tighten only.

7. Install the hoses and couplers.

IMPELLER INSPECTION

REMOVAL

1. Remove six 3/8-16 wing nuts and set aside the handle and lifting eye.

2. Lift the motor adapter plate from the case.

3. To remove the impeller, remove the motor shaft capscrew, lockwasher and flatwasher. Support the

impeller and tap the motor shaft with a plastic mallet.

On units with a polyurethane casing, the impeller is held in place by a capscrew, lockwasher and flatwasher.

INSPECTION

Check the impeller blades for cracks, chips and signs of excessive wear which can effect pump performance. Replace the impeller if damaged or seriously worn.

INSTALLATION

1. Grease the motor shaft with waterproof grease and install on the impeller. On units with a polyurethane casing, install the key.

2. Secure the impeller with the lockwasher, flatwasher and capscrew.

On units with a polyurethane casing, the impeller is held in place by a capscrew, lockwasher and flatwasher.

3. Place the motor adapter plate over the case studs

4. Install the handle and lifting eye on the motor adapter plate and secure with six 3/8-16 wing nuts. Tighten by hand only.

TROUBLESHOOTING

If symptoms of poor performance develop, the following chart can be used as a guide to correct the problem.

When diagnosing faults in operation of the trash pump, always check that the hydraulic power

source is supplying the correct hydraulic flow and pressure to the trash pump as listed in the table. Use a flow meter known to be accurate. Check the flow with the hydraulic fluid temperature at least 80°F/27°C.

| PROBLEM | CAUSE | REMEDY |
|----------------------------------|--------------------------------------------------------------|-----------------------------------------------------------------------------------------------------------------------------------------------------------------------------------------------|
| Pump will not start. | No hydraulic flow or pressure. | Turn on power source and check that 7-9 gpm/26-34 lpm at 1500-2000 psi/101-140 bar is available at the pump. |
| | Defective couplers. | Check the couplers by connecting them together with the hydraulic power source operating and the control valve "ON". The power supply should operate without "loading" from plugged couplers. |
| | Impeller jammed with debris. | Clean the pumping chamber as described in the SERVICE INSTRUCTIONS section of this manual. |
| | Motor failure. | Replace or repair motor. |
| Poor pump performance. | Incorrect hydraulic flow or pressure. | Turn "ON" power source, check that 7-9 gpm/26-34 lpm at 1500-2000 psi/101-140 bar is available at the pump. |
| | Inlet to pump may be blocked. | Inspect and clear. If pump settled into sediment, suspend pump above sediment or place flat, solid surface under the pump. |
| | Discharge hose restricted. | Straighten hose and remove kinks. |
| | Impeller worn excessively. | Replace impeller. |
| Hydraulic oil in discharge flow. | Motor shaft seal failure. | Replace shaft seal. |
| Liner failure, aluminum model. | Pumping very abrasive, corrosive or petroleum based liquids. | Use steel case pump. |

SPECIFICATIONS

| | |
|-----------------------------|-----------------------------------|
| Capacity | 450 gpm/1688 lpm |
| Weight | 64 lbs/29 kg (Steel Case) |
| | 40 lbs/18 kg (Aluminum Case) |
| | 31 lbs/14 kg (Urethane Case) |
| Overall Length | 14-inches/35.5 cm |
| Width | 16 -inches/41 cm |
| Pressure Range | 1500-2000 psi/101-140 bar |
| Flow Range | 7-9 gpm/26-34 lpm |
| Maximum Flow | 9 gpm/34 lpm |
| System Type | O.C., HTMA TYPE 2 |
| Porting | 1/2-inch NPTF |
| Connect Size and Type | 1/2 -inch, Male Pipe |
| Liquid Outlet Size | 3-inch, Camlock |
| | Urethane Case, 3-inch Female Pipe |

NOTE

Weights, dimensions and operating specifications listed are subject to change without notice. Where specifications are critical to your application, please consult the factory.

ACCESSORIES

| PART NO. | DESCRIPTION |
|----------|-----------------------------------------|
| 15248 | 3 inch Camlock Female 2-1/2 NST Male |

WARRANTY

Hand held tools and their parts are warranted against defects in materials and workmanship for a period of twelve months from the date of purchase, except for cutting parts, steels and other parts not manufactured by Stanley (such as impact mechanisms, alternators, regulators and hoses).

The Warranty Registration Card packed with the tool must be filled out and returned to Stanley upon receipt of the tool.

Stanley reserves the right to replace or repair only those parts which under our examination prove to have been defective at the time of purchase.

Shipping charges are pre-paid by the customer unless otherwise authorized by Stanley.

The warranty is void if maximum flow and pressure ratings are exceeded.

There is no other warranty expressed or implied.

PUMP SERIAL NO. 91248, 91295, 91299, 91300, 91305 AND UP.

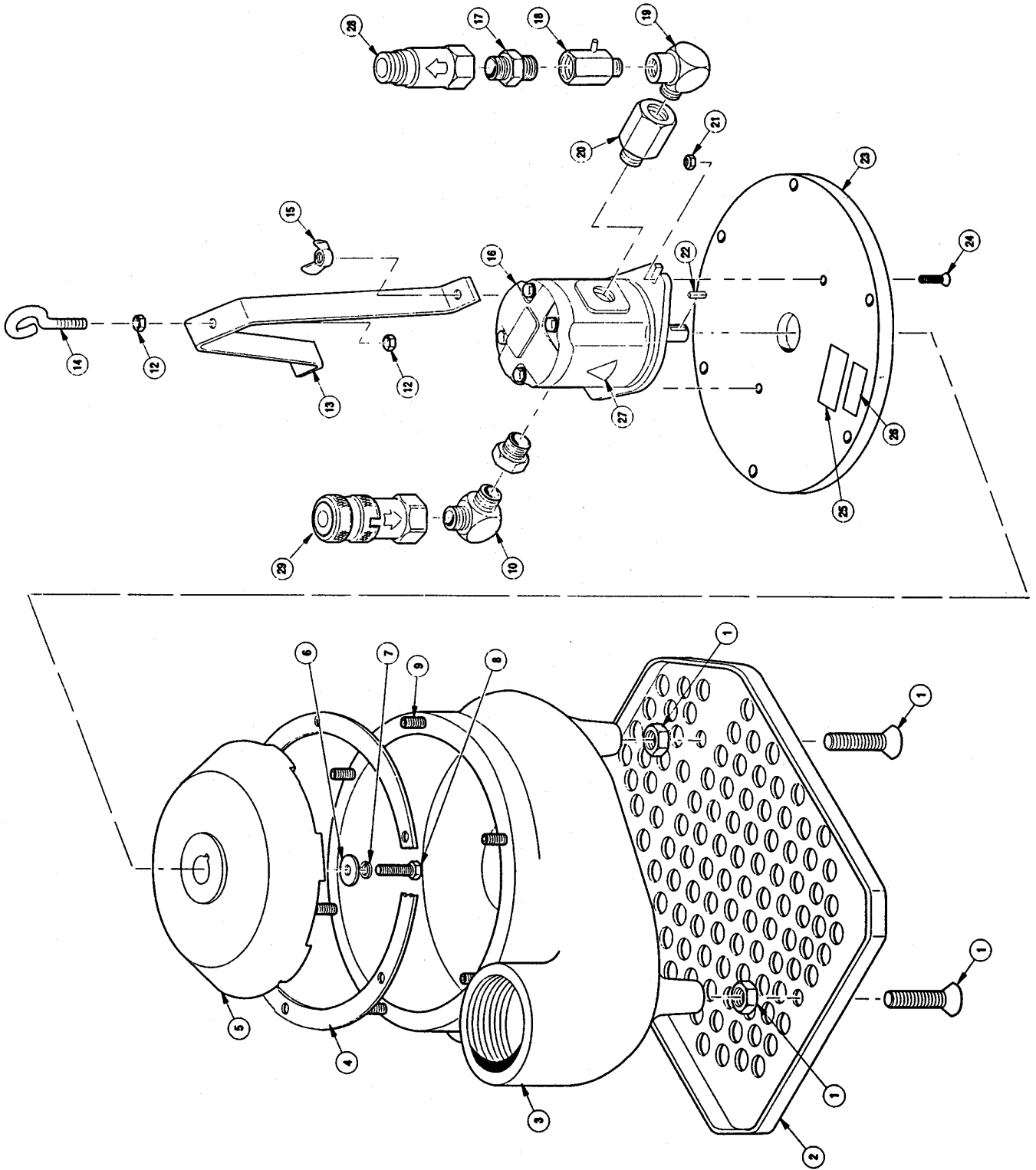

PARTS LIST

| Item No. | Part No. | Qty. | Description |
|----------|----------|------|------------------------------------|
| 1 | 07205 | 3 | Leg Assembly |
| 2 | 07206 | 1 | Pump Support |
| 3 | 21917 | 1 | Casing, Polyurethane |
| 4 | 07201 | 1 | Gasket |
| 5 | 07200 | 1 | Impeller |
| | 17569 | 1 | Impeller, C.I. |
| 6 | 22294 | 1 | Washer, Stainless |
| 7 | 09663 | 1 | Lockwasher |
| 8 | 09661 | 1 | Capscrew |
| 9 | 07209 | 6 | Stud, 3/8-16 x 2 |
| 10 | 02219 | 1 | Elbow, 1/2 NPT |
| 11 | 04547 | 1 | Adapter, 10 SAE / 1/2 NPT Female |
| 12 | 00147 | 2 | Nut, Hex, 3/8-16 |
| 13 | 07207 | 1 | Handle |
| 14 | 07208 | 1 | Eye Bolt, 3/8-16 |
| 15 | 07210 | 6 | Wing Nut 3/8-16 |
| 16 | 24381 | 1 | Hydraulic Motor Assembly |
| 17 | 04192 | 1 | Hex Nipple, 1/2 in. NPT |
| 18 | 07214 | 1 | Check Valve, 1/2 in. NPT |
| 19 | 04025 | 1 | Elbow, 1/2 in. NPTM x 1/2 in. NPTF |
| 20 | 07215 | 1 | Adapter, 12 SAE/ 1/2 NPT Female |
| 21 | 04353 | 2 | Locknut, 3/8-16 |
| 22 | 00635 | 1 | Key, Motor Shaft, 3/16 x 3/4 |
| 23 | 07202 | 1 | Motor Adapter Plate |
| 24 | 07211 | 2 | Screw, Flat Head, 3/8-16 x 1-1/4 |
| 25 | 05152 | 1 | Sticker, Stanley |
| 26 | 03786 | 1 | Sticker, GPM |
| 27 | 11207 | 1 | Circuit Type D Sticker (UK only) |
| 28 | 03976 | 1 | Male Coupler Body (UK only) |
| 29 | 03975 | 1 | Female Coupler Body (UK only) |

NOTE: Use Part Name when Ordering.

SEAL KIT DATA

| Part No. | Qty. | Description |
|--------------------------------|------|---------------------------|
| Seal Kit Part No. 23567 | | |
| 07963 | 1 | Seal Kit |
| 07964 | 1 | Seal |
| 11046 | 1 | Seal Washer |
| 11047 | 1 | Gland/Seal Carrier |
| 11048 | 1 | O-Ring |
| 23566 | 1 | Shaft Seal |
| 21607 | 1 | Installation Illustration |

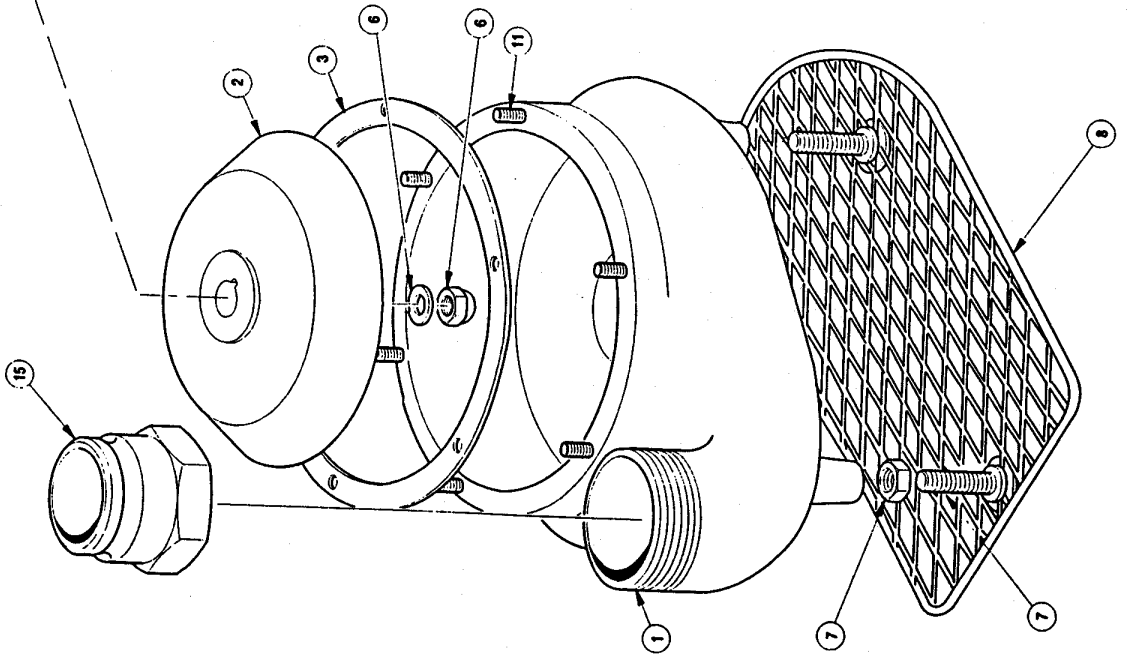
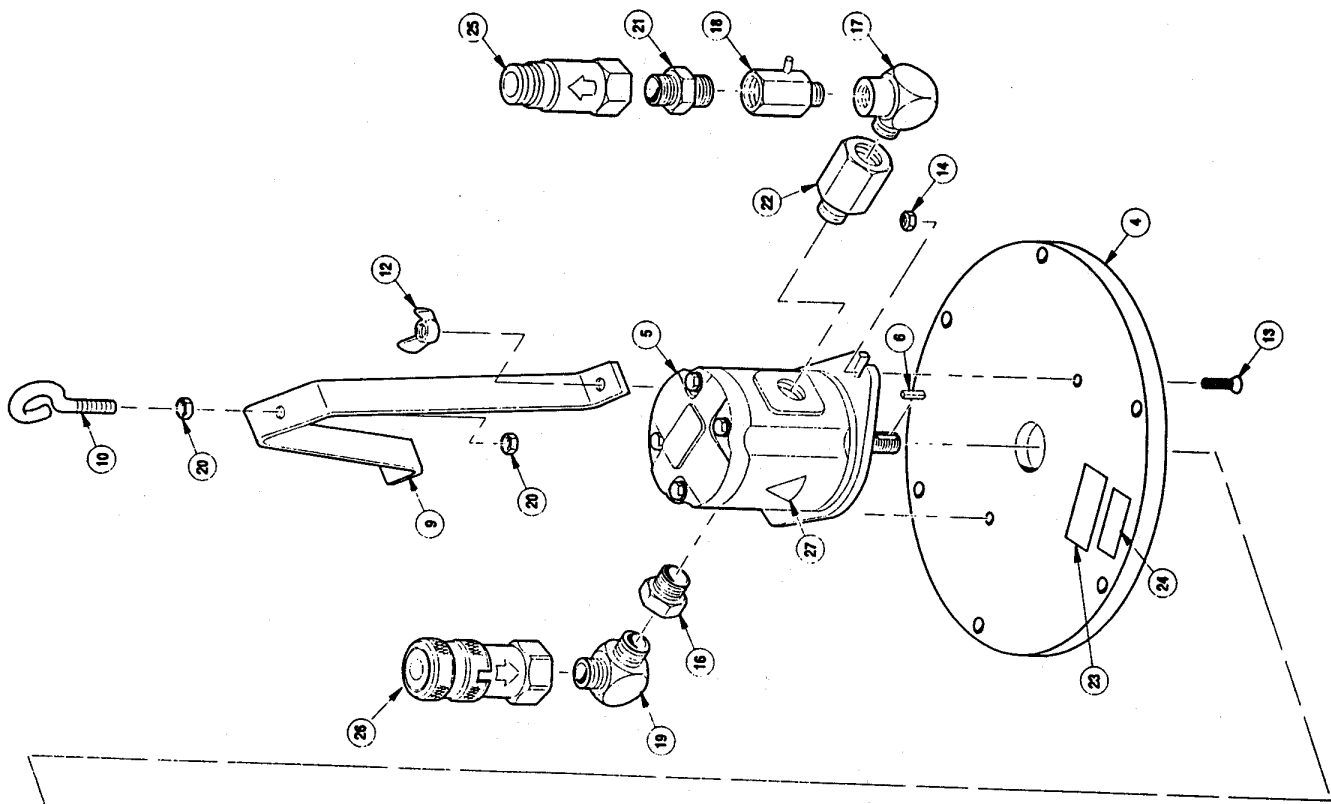

PARTS LIST

| Item No. | Part No. | Qty. | Description |
|----------|----------|------|-----------------------------------------------------------|
| 1 | 07199 | 1 | Casing, Cast Steel * |
| | 07216 | 1 | Casing, Aluminum w/Rubber Liner ** |
| 2 | 07200 | 1 | Impeller |
| | 17569 | 1 | Impeller C.I. |
| 3 | 07201 | 1 | Gasket * |
| 4 | 07202 | 1 | Motor Adaptor Plate |
| | 07203 | 1 | Hydraulic Motor Assy (used on units lower than S/N 93000) |
| 5 | 24381 | 1 | Hydraulic Motor Assy (used on units S/N 93000 and higher) |
| 6 | 07204 | 3 | Capnut Washer and Key |
| 7 | 07205 | 1 | Leg Assembly |
| 8 | 07206 | 1 | Pump Support |
| 9 | 07207 | 1 | Handle |
| 10 | 07208 | 6 | Eye Bolt, 3/8-16 |
| 11 | 07209 | 6 | Stud, 3/8-16 x 2 |
| 12 | 07210 | 2 | Wing Nut, 3/8-16 |
| 13 | 07211 | 2 | Screw, Flat Head, 3/8-16 x 1 1/4 |
| 14 | 04353 | 1 | Locknut, 3/8-16 |
| 15 | 07217 | 1 | Connector, Aluminum ** |
| | 07488 | 1 | Connector, Brass * |
| 16 | 04547 | 1 | Adapter, 10 SAE / 1/2NPT FEM. |
| 17 | 04025 | 1 | Elbow, 1/2" NPTM x 1/2" NPTF |
| 18 | 07214 | 1 | Check Valve, 1/2NPT |
| 19 | 02219 | 2 | Elbow, 1/2NPT |
| 20 | 00147 | 1 | Nut, Hex, 3/8-16 |
| 21 | 04192 | 1 | Hex Nipple, 1/2" NPT |
| 22 | 07215 | 1 | Adapter, 12 SAE / 1/2NPT FEM. |
| 23 | 05152 | 1 | Stanley Sticker |
| 24 | 03786 | 1 | GPM Sticker |
| 25 | 03976 | 1 | Male Coupler Body (UK Only) |
| 26 | 03975 | 1 | Female Coupler Body (UK Only) |
| 27 | 11207 | 1 | Circuit Type D Sticker (UK Only) |

NOTE: Use Part Name when Ordering.

*Used on TP03001

**Used on TP03002

15 is integral with aluminum casing on TP03002 beginning with S/N 86250

SEAL KIT DATA

| Part No. | Qty. | Description |
|--------------------------------|------|---------------------------|
| Seal Kit Part No. 23567 | | |
| 07963 | 1 | Seal Kit |
| 07964 | 1 | Seal |
| 11046 | 1 | Seal Washer |
| 11047 | 1 | Gland/Seal Carrier |
| 11048 | 1 | O-Ring |
| 23566 | 1 | Shaft Seal |
| 21607 | 1 | Installation Illustration |

STANLEY[®]

helps you do things right

Stanley Hydraulic Tools
Division of the Stanley Works
3810 S.E. Naef Road
Milwaukie, OR 97267-5698
Tel: (503) 659-5660
Fax: (503) 652-1780
Telex: 360771

Stanley Power Tools
Nelson Park
Cramlington
Northumberland,
NE 23 9 BL
England
Tel: (44) (670) 713399
Fax: (44) (670) 712701

Stanley Svenska AB
Box 1054
Datavagen 51
S-436 22 Askim, Sweden
Tel: (46) (31) 289774
Fax: (46) (31) 288099

Stanley Tools SPA
Via Trieste 1
22060 Figino Serenza (CO),
Italy
Tel: (30) (31) 785111
Fax: (39) (31) 781766

Stanley Hydraulic Tools Asia
PO Box 425
12 Gul Drive
Jurong Town
Singapore 9161
Tel: (65) 8620833
Fax: (65) 8610901
or (65) 8610901
Telex: RS23945 STANLEY