

TA57 HYDRAULIC TAMPER

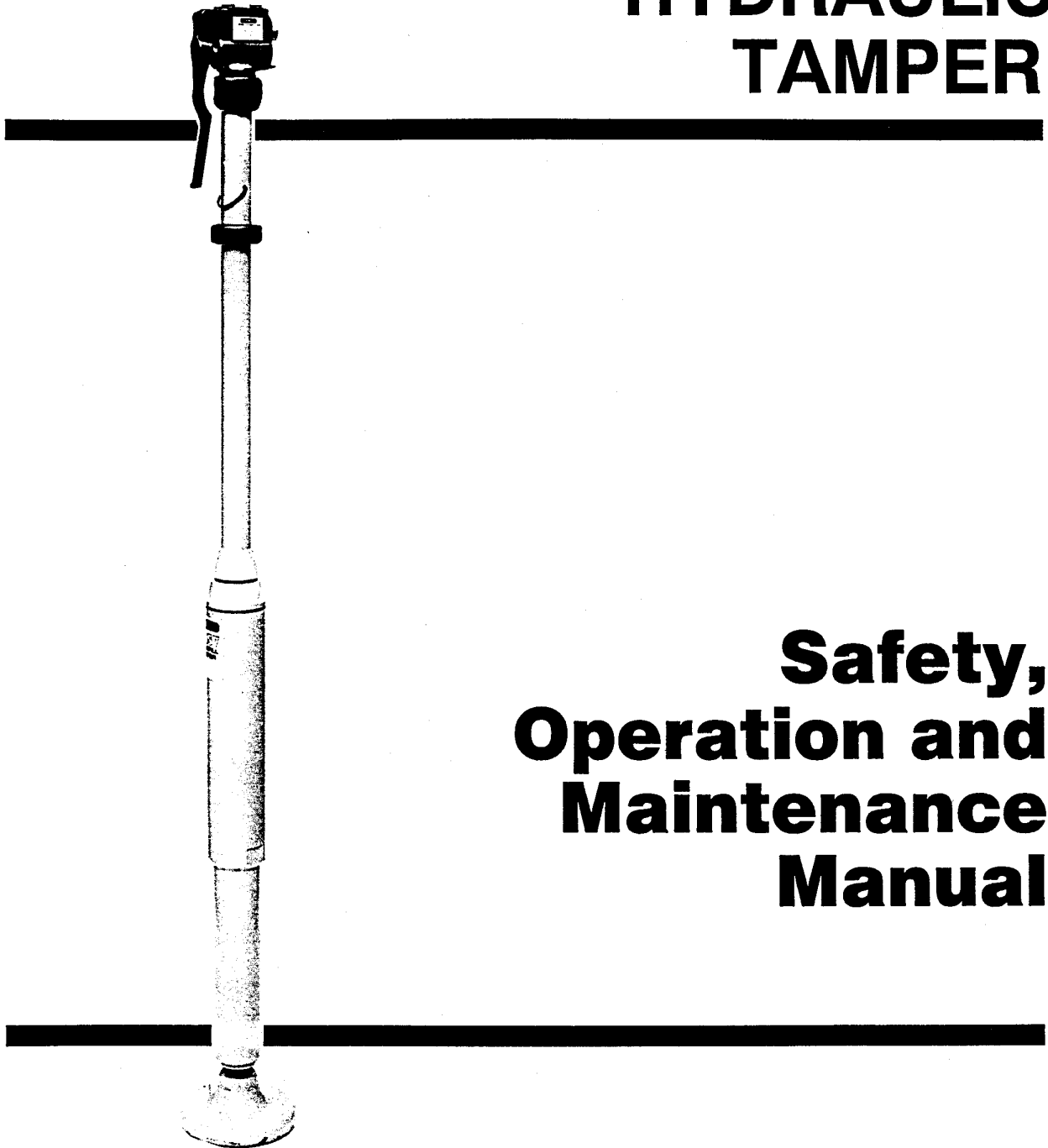

Safety, Operation and Maintenance Manual

Focused on performance™

STANLEY®
helps you do things right

SAFETY PRECAUTIONS

Tool operators and maintenance personnel must always comply with the safety precautions given in this manual and on the stickers and tags attached to the tool and hose.

These safety precautions are provided for your safety. Review them carefully before operating the tool and before performing maintenance or repairs.

Supervising personnel should develop additional precautions relating to the specific work area and local safety regulations. If so, place the added precautions in the space provided on page 3.

GENERAL SAFETY PRECAUTIONS

The TA57 Hydraulic Tamper will provide safe and dependable service if operated in accordance with the instructions given in this manual. Read and understand this manual and any stickers and tags attached to the tamper and hose before operation. Failure to do so could result in personal injury or equipment damage.

- Operators must start in a work area without bystanders. Flying debris can cause serious injury.
- Establish a training program for all operators to ensure safe operation.
- The operator must be familiar with all prohibited work areas such as excessive slopes and dangerous terrain conditions.
- Do not operate the tool unless thoroughly trained or under the supervision of an instructor.
- Always wear safety equipment such as goggles, ear and head protection, and safety shoes at all times when operating the tamper.
- Know the location of buried or covered utility services before starting your work.
- Without the use of non-conductive accessories, this tool is not for use near energized lines. Failure to comply with this warning could result in serious personal injury.
- Use care when handling the tamper. Do not carry the tool by the hoses.
- Never wear loose clothing that can get entangled in the working parts of the tool.
- Do not overreach. Maintain proper footing and balance at all times.
- Do not inspect or clean the tool while the hydraulic power source is connected. Accidental engagement of the tool can cause serious injury.
- Always connect hoses to the tool hose couplers before energizing the hydraulic power source. Be sure all hose connections are tight.
- Do not operate the tool at oil temperatures above 140°F/60°C. Operation at higher temperatures can cause higher than normal temperatures at the tool which can result in operator discomfort.
- To avoid personal injury or equipment damage, all tool repair, maintenance and service must only be performed by authorized and properly trained personnel.

TOOL STICKERS AND TAGS

The safety related stickers and tags attached to the tamper prior to shipment from the factory are shown below.

The pressure and flow rates specified must never be exceeded. All stickers and tags must be read and understood prior to operating the tool.

The information listed on stickers and tags must be legible at all times. Always replace stickers that have become worn or damaged. Replacements are available from your local Stanley distributor.

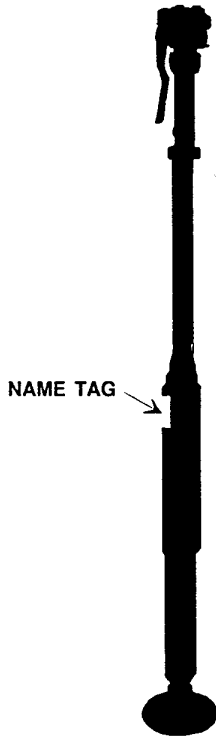

NAME TAG

SAFETY TAG

The safety tag at right is attached to the tamper when shipped from the factory. Read and understand the safety instructions listed on this tag before removal. We suggest you retain this tag and attach it to the tie tamper when not in use.

DANGER

1. FAILURE TO USE HYDRAULIC HOSE LABELED AND CERTIFIED AS NON-CONDUCTIVE WHEN USING HYDRAULIC TOOLS ON OR NEAR ELECTRICAL LINES MAY RESULT IN DEATH OR SERIOUS INJURY.
BEFORE USING HOSE LABELED AND CERTIFIED AS NON-CONDUCTIVE ON OR NEAR ELECTRICAL LINES BE SURE THE HOSE IS MAINTAINED AS NON-CONDUCTIVE. THE HOSE SHOULD BE REGULARLY TESTED FOR ELECTRIC CURRENT LEAKAGE IN ACCORDANCE WITH YOUR SAFETY DEPARTMENT INSTRUCTIONS.
2. A HYDRAULIC LEAK OR BURST MAY CAUSE OIL INJECTION INTO THE BODY OR CAUSE OTHER SEVERE PERSONAL INJURY.
 - A. DO NOT EXCEED SPECIFIED FLOW AND PRESSURE FOR THIS TOOL. EXCESS FLOW OR PRESSURE MAY CAUSE A LEAK OR BURST.
 - B. DO NOT EXCEED RATED WORKING PRESSURE OF HYDRAULIC HOSE USED WITH THIS TOOL. EXCESS PRESSURE MAY CAUSE A LEAK OR BURST.
 - C. CHECK TOOL HOSE COUPLERS AND CONNECTORS DAILY FOR LEAKS. DO NOT FEEL FOR LEAKS WITH YOUR HANDS. CONTACT WITH A LEAK MAY RESULT IN SEVERE PERSONAL INJURY.

IMPORTANT

READ OPERATION MANUAL AND SAFETY INSTRUCTIONS FOR THIS TOOL BEFORE USING IT.

USE ONLY PARTS AND REPAIR PROCEDURES APPROVED BY STANLEY AND DESCRIBED IN THE OPERATION MANUAL.

TAG TO BE REMOVED ONLY BY TOOL OPERATOR.

SEE OTHER SIDE 15875

DANGER

- D. DO NOT LIFT OR CARRY TOOL BY THE HOSES. DO NOT ABUSE HOSE. DO NOT USE KINKED, TORN OR DAMAGED HOSE.
3. MAKE SURE HYDRAULIC HOSES ARE PROPERLY CONNECTED TO THE TOOL BEFORE PRESSURIZING SYSTEM. SYSTEM PRESSURE HOSE MUST ALWAYS BE CONNECTED TO TOOL. "OUT" PORT RETURN HOSE MUST ALWAYS BE CONNECTED TO TOOL. "OUT" PORT REVERSING CONNECTIONS MAY CAUSE REVERSE TOOL OPERATION WHICH CAN RESULT IN SEVERE PERSONAL INJURY.
4. DO NOT CONNECT CLOSED-CENTER TOOLS TO OPEN-CENTER HYDRAULIC SYSTEMS. THIS MAY CAUSE EXTREME SYSTEM HEAT AND/OR SEVERE PERSONAL INJURY.
DO NOT CONNECT OPEN-CENTER TOOLS TO CLOSED-CENTER HYDRAULIC SYSTEMS. THIS MAY RESULT IN LOSS OF OTHER HYDRAULIC FUNCTIONS POWERED BY THE SAME SYSTEM AND/OR SEVERE PERSONAL INJURY.
5. BYSTANDERS MAY BE INJURED IN YOUR WORK AREA. KEEP BYSTANDERS CLEAR OF YOUR WORK AREA.
6. WEAR HEARING, EYE, FOOT, HAND AND HEAD PROTECTION.
7. TO AVOID PERSONAL INJURY OR EQUIPMENT DAMAGE, ALL TOOL REPAIR, MAINTENANCE AND SERVICE MUST ONLY BE PERFORMED BY AUTHORIZED AND PROPERLY TRAINED PERSONNEL.

IMPORTANT

READ OPERATION MANUAL AND SAFETY INSTRUCTIONS FOR THIS TOOL BEFORE USING IT.

USE ONLY PARTS AND REPAIR PROCEDURES APPROVED BY STANLEY AND DESCRIBED IN THE OPERATION MANUAL.

TAG TO BE REMOVED ONLY BY TOOL OPERATOR.

SEE OTHER SIDE 15875

SAFETY SYMBOLS

Safety symbols are used to emphasize all operator, maintenance and repair actions which, if not strictly followed, could result in a life-threatening situation, bodily injury or damage to equipment.

<p style="text-align: center;">DANGER</p> <p>This safety symbol may appear on the tool. It is used to alert the operator of an action that could place him/her or others in a life threatening situation.</p>
--

<p style="text-align: center;"> WARNING</p> <p>This safety symbol appears in these instructions to identify an action that could cause bodily injury to the operator or other personnel.</p>
--

<p style="text-align: center;">IMPORTANT</p> <p>This safety symbol appears in these instructions to identify an action or condition that could result in damage to the tool or other equipment.</p>
--

Always observe safety symbols. They are included for your safety and for the protection of the tool.

LOCAL SAFETY REGULATIONS

Enter any local safety regulations here. Keep these instructions in an area accessible to the operator and maintenance personnel.

EQUIPMENT PROTECTION AND CARE

IMPORTANT

In addition to the Safety Precautions on pages 1 thru 3 of this manual, observe the following for equipment protection and care.

- Always store the tamper in a clean, dry space, safe from damage or pilferage.
- Always keep critical tool markings, such as labels and warning stickers legible.
- Always replace hoses, couplings and other parts with replacement parts recommended by Stanley Hydraulic Tools. Supply hoses must have a minimum working pressure rating of 2500 psi/175 bar. All hoses must have a fluid resistant inner surface and an abrasive resistant outer surface.
- Tool repair should be performed by experienced personnel only.
- Make sure all couplers are wiped clean before connecting them.
- Make certain that the recommended relief valves are installed in the pressure side of the system.
- The hydraulic circuit control valve must be in the "OFF" position when coupling or uncoupling hydraulic tools. Failure to do so may result in damage to the quick disconnect couplers and cause over-heating of the hydraulic system.
- Operate the tool within its rated capacity. Do not expect a small tamper to do the job of larger models.
- Do not use the tool for applications for which it was not designed. Do not attempt to compact broken concrete or asphalt rubble. Tampers are intended for compactable materials only.
- Never operate a tamper without holding it against the work surface.

HYDRAULIC HOSE REQUIREMENTS

HOSE TYPES

Hydraulic hose types authorized for use with Stanley Hydraulic Tools are as follows:

- ① Labeled and certified non-conductive
- ② Wire braided (conductive)
- ③ Fabric braided (not certified or labeled non-conductive)

Hose ① listed above is the only hose authorized for use near electrical conductors.

Hoses ② and ③ listed above are **conductive** and **must never** be used near electrical conductors.

To help ensure your safety, the following DANGER tags are attached to all hoses purchased from Stanley Hydraulic Tools. **DO NOT REMOVE THESE TAGS.**

If the information on a tag is illegible because of wear or damage, replace the tag immediately. A new tag can be obtained at no charge from your Stanley distributor.

① CERTIFIED NON-CONDUCTIVE

This tag is attached to all certified and labeled non-conductive hose.

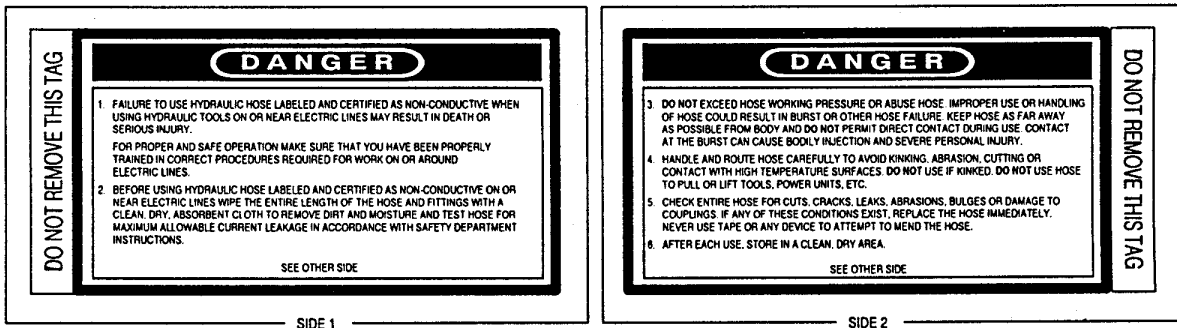

② AND ③ WIRE- AND FABRIC-BRAIDED (NOT CERTIFIED OR LABELED NON-CONDUCTIVE)

This tag is attached to all **conductive** hose.

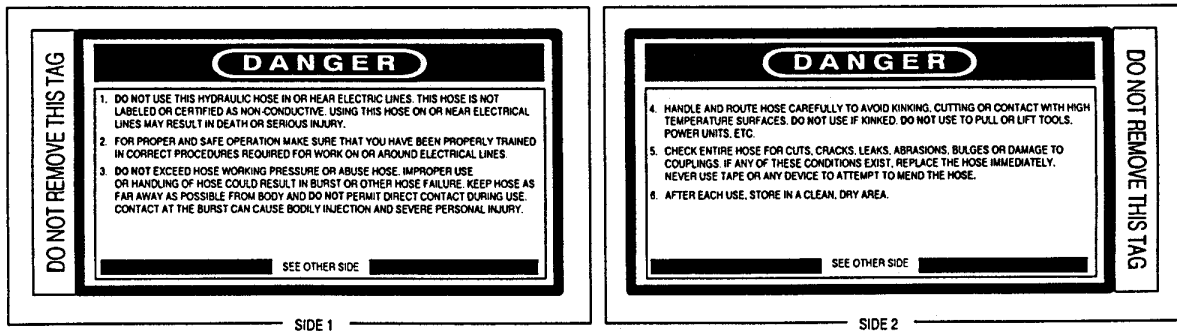

HOSE PRESSURE RATING

The rated working pressure of the hydraulic hose **must be equal to or higher than** the relief valve setting on the hydraulic system used to power the tamper.

HYDRAULIC SYSTEM REQUIREMENTS

- The hydraulic system should provide a flow of 7-9 gpm/26-34 lpm at an operating pressure of 2000 psi/140 bar. Recommended relief valve settings are 2150-2250 psi/145-155 bar.
- The system should not have more than 250 psi/17 bar backpressure measured at the tool end of the operating hoses. The system conditions for measurement are at maximum fluid viscosity or 400 ssu/82 centistokes (minimum operating temperatures).
- The hydraulic system should have sufficient heat rejection capacity to limit the maximum oil temperature to 140° F/60° C at the maximum expected ambient temperature. The recommended minimum cooling capacity is 5 hp/3.73 kW at a 40° F/22° C difference between ambient temperature and oil temperature.
- The hydraulic system should have a minimum of 25 micron filtration. It is recommended that filter elements be sized for a flow of at least 30 gpm/114 lpm for cold temperature startup and maximum dirt holding capacity.
- The hydraulic fluid used should have a viscosity between 100 and 400 ssu/20 and 82 centistokes at the maximum and minimum expected operating temperatures. Petroleum base hydraulic fluids with antiwear properties and a viscosity index over 140 will meet the recommended requirements over a wide range of operating temperatures.
- The recommended hose size is 0.500 inch/12 mm I.D. to 50 ft/15 m long and 0.625 inch/16 mm I.D. minimum up to 100 ft/30 m long.

OPERATION

PREOPERATION PROCEDURES

CHECK POWER SOURCE

1. Using a calibrated flowmeter and pressure gauge, check that the hydraulic power source develops a flow of 7-9 gpm/26-34 lpm at 1000-2000 psi/70-140 bar.

2. Make certain that the hydraulic power source is equipped with a relief valve set to open at 2250 psi/155 bar maximum.

CONNECT HOSES

1. Wipe all hose couplers with a clean lint-free cloth before making connections.

2. Connect hoses from the hydraulic power supply to the quick couplers on the tool hoses. It is a good practice to connect return hoses first and disconnect them last to minimize or avoid trapped pressure within the tool.

3. Observe the flow indicators stamped on hose couplers to ensure that the oil flow will be in the proper direction. The female coupler on the tool is the inlet coupler. The IN and OUT ports are marked on the valve body.

Note: If uncoupled hoses are left in the sun, pressure increase inside the hoses may make them difficult to connect. When possible, connect the free ends of the operating hoses together.

OPERATING PROCEDURES

TOOL OPERATION

1. Observe all safety precautions.

2. Place the tamper on the surface to be compacted.

3. Squeeze the trigger to start the tamper.

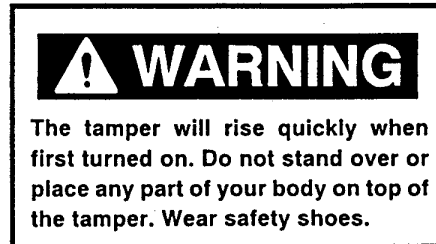

Note: Partially pressing the trigger allows the tool to run at a slow speed, making it easier to start or control.

4. Guide the tamper using both hands. One on the on-off valve trigger and the other at the tapered section at the end of the handle tube.

5. When backfilling a deep hole, compact (tamp) the backfill after a maximum of 6 inches/15 cm of material is added to the hole. This will ensure maximum compaction of the filled hole and minimize any settling that may occur.

COLD WEATHER OPERATION

If the tamper is to be used during cold weather, preheat the hydraulic fluid at low engine speed. When using the normally recommended fluid, fluid temperature should be at or above 50° F/10° C (400 ssu/82 centistrokes) before use.

Damage to the hydraulic system or tamper can result from use with fluid that is too viscous or thick.

SERVICE INSTRUCTIONS

Good maintenance practices will keep the tamper on the job and increase its service life.

The single-most important maintenance practice is to keep the hydraulic fluid clean at all times. Contaminated hydraulic fluid causes rapid wear and/or failure of internal parts.

Follow the procedures contained in the HYDRAULIC SYSTEMS REQUIREMENTS section of this manual to ensure peak performance from the tamper.

Never disassemble the tamper unless proper troubleshooting procedures have isolated the problem to an internal part. Then, only disassemble it to the extent necessary to replace the defective part. **KEEP CONTAMINANTS SUCH AS DIRT AND GRIT AWAY FROM INTERNAL PARTS AT ALL TIMES.**

Always determine and correct the cause of the problem prior to reassembly. Further wear and tool failure can result if the original cause is not corrected.

PRIOR TO DISASSEMBLY

- Clean exterior of tool.
- Obtain seal kit Part Number 07390 so you can replace all seals exposed during disassembly. Note orientation of seals before removing them. Install new seals in the same way.

TAMPER DISASSEMBLY

1. Place the tamper in a vise, clamping across the flats on the large O.D. outer cylinder.
2. Place a wrench across the flat portion of the on-off valve body. Slide the protective cover off the retaining nut and loosen the nut with a 2-1/8 inch wrench.
3. Pull the valve body away from the handle assembly. (The oil tubes may come out with the valve body; if they remain in the handle assembly, they can be removed when the handle assembly is removed).

4. Place a 2-1/2 inch wrench across the flats of the tube nut and loosen the lock nut on the handle assembly with a 2-1/8 inch wrench.
 5. Pull the handle assembly away from the tamper body and remove oil tubes (if not removed in prior step 3).
 6. Remove the tube nut with a 2-1/2 inch wrench.
- Note:** Disassembly of the tamper (steps 1 through 6) is required to check or charge the accumulator.
7. Discharge accumulator by depressing valve core.
 8. Place a 1-3/4 inch wrench across the flats on the shoe and remove the taper nut with a 1 inch socket wrench.
 9. Remove the shoe from the piston taper.

10. Push the piston towards the handle end. The accumulator assembly, porting block, automatic valve, push rod and associated parts will be forced out ahead of the piston. Set these parts aside.

IMPORTANT

If you must push the piston through the flow sleeve, use an aluminum rod or wooden dowel as a pusher to avoid damaging the piston bore.

11. Remove the outer cylinder and flow sleeve tube from the vise. Stand the assembly (small end down) on a flat surface and push the outer cylinder down over the flow sleeve tube for removal.
12. To remove the automatic valve body and flow sleeve from the flow sleeve tube, use the following procedure. Place Part Number 05047 Bridge Plate from the Part Number 05064 Bearing Puller Kit across the opening of an arbor press. Stand the flow sleeve tube assembly on the Bridge Plate with the exposed portion of the automatic valve body (approximately 1-3/4 inches/44.5 mm long) projecting through the hole. Place Part Number 12124 Flow Sleeve Pusher on the exposed end of the flow sleeve and push the flow sleeve and automatic valve body out of the flow sleeve tube. Socket extensions can be used to push parts

completely out of the flow sleeve tube if the arbor press ram is too large to fit inside the flow sleeve tube.

IMPORTANT
The automatic valve body and flow sleeve will drop once they clear the end of the flow sleeve tube. Make sure to grasp these parts as they are being pushed out.

The following procedure can be used if an arbor press is not available. Place Part Number 04910 Flow Sleeve Removal Tube on a flat surface with a rag inside.

Place Part Number 05047 Bridge Plate on top of Flow Sleeve Removal Tube. Proceed as above using a soft faced hammer on Part Number 12124 Flow Sleeve Pusher to drive the parts out.

IMPORTANT
Once the automatic valve body drops free, remove it from the flow sleeve tube to avoid being damaged by the flow sleeve as it is driven out.

13. To service the lower piston seals, pull the rod wiper out using an oil seal puller, screwdriver or bearing puller. Remove the felt wiper, Spirol® retaining ring and seal washer to access the cup seal. Note orientation of the cup seal for reference during assembly.

WARNING
Make sure accumulator is discharged before proceeding with the next step

14. To service the accumulator and push rod tube seals, separate the porting block from the accumulator assembly. Pull the push rod tube out of the part that it remains with once the above parts have been pulled apart. Place a rag in the bottom of Part Number 04910 Flow Sleeve Removal Tube and place accumulator assembly, charge valve down, on the tube with Part Number 10589 Split Rings in the groove between the accumulator cylinder and accumulator chamber.

Press the accumulator apart using an arbor press. Place Part Number 12124 Flow Sleeve Pusher on top of accumulator chamber to avoid damage.

15. Carefully cut the diaphragm along its length for removal.

IMPORTANT
Take care to avoid damaging seal grooves.

16. To disassemble the on-off valve, drive the two 5/32 inch/4 mm diameter roll pins out of the trigger. Once removed, the trigger, spring and valve spool may be removed from the valve body. Carefully remove the o-rings from within the valve spool bore using o-ring service tools.

PRIOR TO ASSEMBLY

- Clean all parts with a degreasing solvent.
- Ensure that all seals that were exposed have been replaced with new parts.
- Apply clean grease or o-ring lubricant to all parts during reassembly.

TAMPER ASSEMBLY

1. Install new o-rings within the spool bore of the on-off valve body. Insert the valve spool assembly, small end first through the valve body, from the side opposite the trigger.

Place the valve spring on the valve spool projecting through the trigger side, followed by the trigger. Align the trigger with the corresponding holes in the valve spool and valve body using a 1/8 inch or 5/32 inch/3 or 4 mm diameter punch and drive the 5/32 inch/4 mm diameter roll pins into place.

2. Apply a light coating of WD-40 to the accumulator chamber and slide the accumulator diaphragm into place on the accumulator chamber.

3. Use grease or rubber lubricant on the inside of the accumulator cylinder and outside of accumulator diaphragm. Push the accumulator chamber/diaphragm assembly halfway into accu-

mulator cylinder. Be sure that the accumulator diaphragm is free of wrinkles and the seal bead is in its groove before proceeding. An arbor press is best used to complete the assembly, using short movements during the last 1/2 inch/12.5 mm of travel to gently seat the diaphragm.

IMPORTANT

Do not use a hammer or powered arbor press to assemble the accumulator.

4. Test charge the accumulator as follows:

- A. Place the assembly in a vise with soft jaws clamping it lengthwise.

IMPORTANT

Do not overtighten and distort the accumulator.

- B. Charge the accumulator to 400 psi/27.5 bar and check for leaks.
- C. Discharge accumulator and remove from the vise.

5. Replace the seals on the push rod tube. Note that the backup rings are installed first followed by the o-rings. (Backup rings to be on the inside.)

6. Insert the push rod tube into the accumulator assembly.

7. Push the porting block onto the exposed end of the push rod tube until it pilots with the I.D. of the accumulator cylinder.

8. Install the lower piston seals as follows:

Install the cup seal into the flow sleeve counterbore (lip side first) followed by the seal washer and retaining ring.

Install the felt washer followed by the wiper seal (lip side out). Press the wiper into its bore until flush with the end of the flow sleeve.

9. Stand the flow sleeve tube (small end down) on a flat surface. Install a new o-ring on the flow sleeve O.D. and lubricate its entire length. Insert the flow sleeve (o-ring end first) into the flow sleeve

tube, placing Part Number 05640 Accumulator Cylinder Puller or an aluminum disc on top of the flow sleeve and drive with a soft faced hammer until flush with the end of the flow sleeve tube. Place the automatic valve body (counterbored end up) on top of the flow sleeve aligning the dowel pin with the appropriate hole. Place the Part Number 05640 Accumulator Cylinder Puller on top of the automatic valve body and drive the assembly together until the flow sleeve bottoms on the flat work surface.

Place Part Number 05047 Bridge Plate across the opening of an arbor press and stand the flow sleeve tube assembly (small end down) on the bridge plate, centered over the hole. Place the Part Number 05640 Accumulator Cylinder Puller between the automatic valve body and arbor press ram. Press until the flow sleeve shoulders on the retaining ring inside flow sleeve tube.

Note: The automatic valve body will project approximately 1-3/4 inches/44.5 mm from the end of the flow sleeve tube.

10. Lubricate and insert the piston (threaded end first) through the automatic valve body and into the flow sleeve.

11. Lubricate and insert the push rod (large end first) into the automatic valve body.

12. Install four push pins (tapered end up), in the flow sleeve.

Note: The push pins must be installed such that the flat, ground faces bear on the flange of the automatic valve.

13. Insert the automatic valve (long end first) into the automatic valve body.

14. Install two push pins (tapered end up) in the porting block. (See note above.)

15. Place the accumulator/porting block assembly over the exposed end of the push rod until it engages with the automatic valve body with proper dowel pin alignment.

16. Make sure that the entire outside diameter of the flow sleeve tube is clean and that the outside sealing diameter adjacent to the external retaining ring is free of burrs and nicks.

17. Replace the internal o-ring seal within the outer

cylinder and place it on a bench vise, lightly clamping across the flats.

18. Lubricate the external seal diameter of the flow sleeve tube and external o-ring on the accumulator chamber and slide this assembly as a unit through the threaded end of the outer cylinder (piston end first).

Once the o-rings engage the mating parts, a soft faced hammer may be required to fully seat the external retaining ring of the flow sleeve tube on the inside shoulder of the outer cylinder. Keep pressure on the end of the accumulator chamber as you drive it in, to keep it from bouncing.

19. Charge the accumulator with nitrogen as described in ACCUMULATOR CHARGING PROCEDURES on page 14.

20. Replace the oil tube o-rings in the on-off valve body and accumulator chamber if not done previously.

Note: These seals are white or cream colored polyurethane.

21. Thread the tube nut into the outer cylinder and tighten securely with a 2-1/2 inch wrench.

Note: Apply anti-seize compound to the threads and end face of the tube nut.

22. Insert the two oil tubes into the ports of the accumulator chamber.

Note: The oil tube port with two visible holes at its bottom is the pressure/inlet side. The oil tube installed in this port should be coated with red Dykem on its ends for later identification.

23. Slide the handle assembly over the oil tubes and thread the tube jam nut into the tube nut and tighten to 200 lb ft/270 Nm with a 2-1/8 inch wrench. Use 242 Loctite on tube jam nut threads.

Note: Locate the trigger bale on the side opposite the pressure oil tube.

24. Push the on-off valve assembly over the oil tubes until mating with the handle tube flare.

Note: The pressure oil tube port is located on the side opposite the trigger and should be installed on the oil tube previously identified with red Dykem.

25. Apply Loctite 242 to the tube nut threads of the on-off valve body. Place a wrench across the flats. Tighten the tube nut to 200 lb ft/270 Nm with a 2-1/8 inch wrench. Slide the protective cover back in place over the tube nut.

IMPORTANT

Do not let the valve body rotate relative to the tamper body to avoid twisting the oil tubes within the handle assembly.

26. Place the shoe on the end of the piston taper.

27. Lubricate the threads and taper of the taper nut with anti-seize compound and install with a torque of 75 lb-ft/100 Nm.

CHARGING THE ACCUMULATOR

ACCUMULATOR TESTING PROCEDURE

Perform disassembly steps 1 through 6 and assembly steps 21 through 25.

The Accumulator Charge kit Part Number 06545 is available for accumulator charging.

To check or charge the accumulator the following equipment is required:

Accumulator tester Part Number 02835.

Charging assembly Part Number 06545 (includes a regulator, hose and fittings).

NITROGEN bottle with a 600 psi/70 bar minimum charge.

1. Holding the chuck end of Stanley tester Part Number 02835, turn the gauge fully counterclockwise to ensure that the stem inside the chuck is completely retracted.

2. Thread the tester onto the charging valve of the tool accumulator (do not advance the gauge-end into the chuck end. Turn as a unit). Seat the chuck on the accumulator charging valve; hand tighten only.

3. Advance the valve stem by turning the gauge-end clockwise until a pressure is read on the gauge (charge pressure should be 300-500 psi/20-34 bar).

4. If pressure is OK unscrew the gauge-end from the chuck to retract the stem, then unscrew the entire tester assembly from the tool accumulator charging valve. If pressure is low, charge the accumulator as described in the following section.

ACCUMULATOR CHARGING PROCEDURE

1. Perform steps 1 through 4 of the accumulator testing procedure.

2. Connect the chuck of the charging assembly to the charging valve on the accumulator tester or, if preferred, remove the tester from the tool charging

valve and connect the charging assembly chuck directly to the tool charging valve.

3. Adjust the regulator to the charging pressure of 400 psi/28 bar.

Note: It may be necessary to set the regulator at 450-500 psi/31-34 bar to overcome any pressure drop through the charging system.

4. Open the valve on the charging assembly hose.

5. When the accumulator is fully charged close the valve on the charging assembly hose and remove the charging assembly chuck from the accumulator tester or tool charging valve.

6. If the accumulator tester has been used, be sure to turn the gauge-end fully counterclockwise before removing the tester from the charging valve of the tool.

TROUBLESHOOTING

If symptoms of poor performance develop, the following chart can be used as a guide to correct the problem.

When diagnosing faults in operation of the tamper, always check that the hydraulic power source is

supplying the correct hydraulic flow and pressure to the tamper as listed in the table. Use a flow meter known to be accurate. Check the flow with the hydraulic fluid temperature at least 80°F/27°C.

PROBLEM	CAUSE	REMEDY
Tamper does not run.	Power unit not functioning.	Check power unit for proper flow and pressure (7-9 gpm/26-34 lpm, 1000-2000 psi/70-140 bar).
	Couplers or hoses blocked.	Remove restriction.
	Pressure and return line hoses reversed at ports or oil tubes.	Be sure hoses/oil tubes are connected to their proper ports.
	High backpressure.	Check hydraulic system for excessive backpressure (over 250 psi/17 bar) measured at the end of the tool operating hoses.
	Mechanical failure of piston, push rod or automatic valve.	Disassemble tamper and inspect for damaged parts.
Tamper does not compact effectively.	Power unit not functioning.	Check power unit for proper flow and pressure (7-9 gpm/26-34 lpm, 1000-2000 psi/70-140 bar).
	Couplers or hoses blocked.	Remove restriction.
	Accumulator charge (pressure hose will pulse more than normal).	Recharge accumulator. Replace diaphragm if charge loss continues.
	Oil too hot (above 140°F/60°C).	Provide cooler to maintain proper oil temperature (100-130° F/38-54° C).
	Back fill material not compactable.	Remove solid materials.
	High backpressure.	Check hydraulic system for excessive backpressure (over 250 psi/17 bar) measured at the end of the tool operating hoses.

PROBLEM	CAUSE	REMEDY
Tammer operates slow.	Couplers or hoses blocked.	Remove restriction.
	Low gpm supply from power unit.	Check power unit for proper flow 7-9 gpm/26-34 lpm.
	Oil too hot (above 140°F/60°C) or too cold (below 60°F/15.5°C).	Check power unit for proper oil temperature. Bypass cooler to warm oil up or provide cooler to maintain proper temperature.
	High backpressure.	Check hydraulic system for excessive backpressure (over 250 psi/17 bar) measured at the end of the tool operating hoses.
	Damaged piston or push rod.	Replace piston and flow sleeve or push rod and automatic valve body as required.
	System relief valve set too low.	Adjust relief valve to 2100-2250 psi/145-155 bar.
Tammer get hot.	Hot oil going through tool.	Check power unit. Be sure flow rate is not too high causing excess oil to go through the relief valve. Provide cooler to maintain proper oil temperature (100-130° F/38-54° C). Check relief valve setting.
		Eliminate flow control devices.
Oil leakage on piston.	Lower piston seal failure.	Replace seal.
Oil leakage through handle tube.	Oil tube seal failure.	Replace oil tube seals.
Oil leakage around trigger.	Valve spool seal failure.	Replace seals.
Piston extends but does not reciprocate.	Pressure and return reversed.	Correct for proper flow direction at power unit or tool. Check to ensure oil tube connections were not reversed.
	Tool not assembled correctly.	Review service instructions for proper assembly. Make sure all parts are installed.

SPECIFICATIONS

Weight	39 lbs/17.7 kg
Pressure Range	1500-2000 psi/105-140 bar
Flow Range	7-9 gpm/26-34 lpm
Optimum Flow	8 gpm/30 lpm
Connect Size	8 SAE o-ring port in valve body handle
Porting	8 SAE o-ring
Length	48 in./122 cm/54 in./137 cm
Body diameter	3 in./7.6 cm
Shoe Diameter	6 in./15.25 cm
System Type	HTMA TYPE II, o.c.
Hose Whips	No

NOTE

Weights, dimensions, and operating specifications listed are subject to change without notice. Where specifications are critical to your application, please consult the factory.

ACCESSORIES

PART NO.	DESCRIPTION
08252	Square Shoe 6 x 6 in.
TOOLS	
01120	Tamper Sleeve Tool
01949	Sleeve Alignment Tool
04337	O-ring Tool Kit
04910	Flow Sleeve Removal Tube
05047	Bridge Plate (included in 05064 Bearing Puller Kit)
05640	Accumulator Cylinder Puller
07390	Seal Kit - TA57
10589	Split Rings
12124	Flow Sleeve Pusher
02853	Accumulator Tester
03189	20 gpm/75 lpm Flowmeter
04182	Flow and Pressure Tester
06545	Accumulator Charge Kit

WARRANTY

Hand held tools and their parts are warranted against defects in materials and workmanship for a period of 12 months from the date of purchase, except for cutting parts, steels and other parts not manufactured by Stanley (such as impact mechanisms, alternators, regulators and hoses).

The Warranty Registration Card packed with the tool must be filled out and returned to Stanley upon receipt of the tool.

Stanley reserves the right to replace or repair only those parts which under our examination prove to have been defective at the time of purchase.

Shipping charges are pre-paid by the customer unless otherwise authorized by Stanley.

The warranty is void if maximum flow and pressure ratings are exceeded.

There is no other warranty expressed or implied.

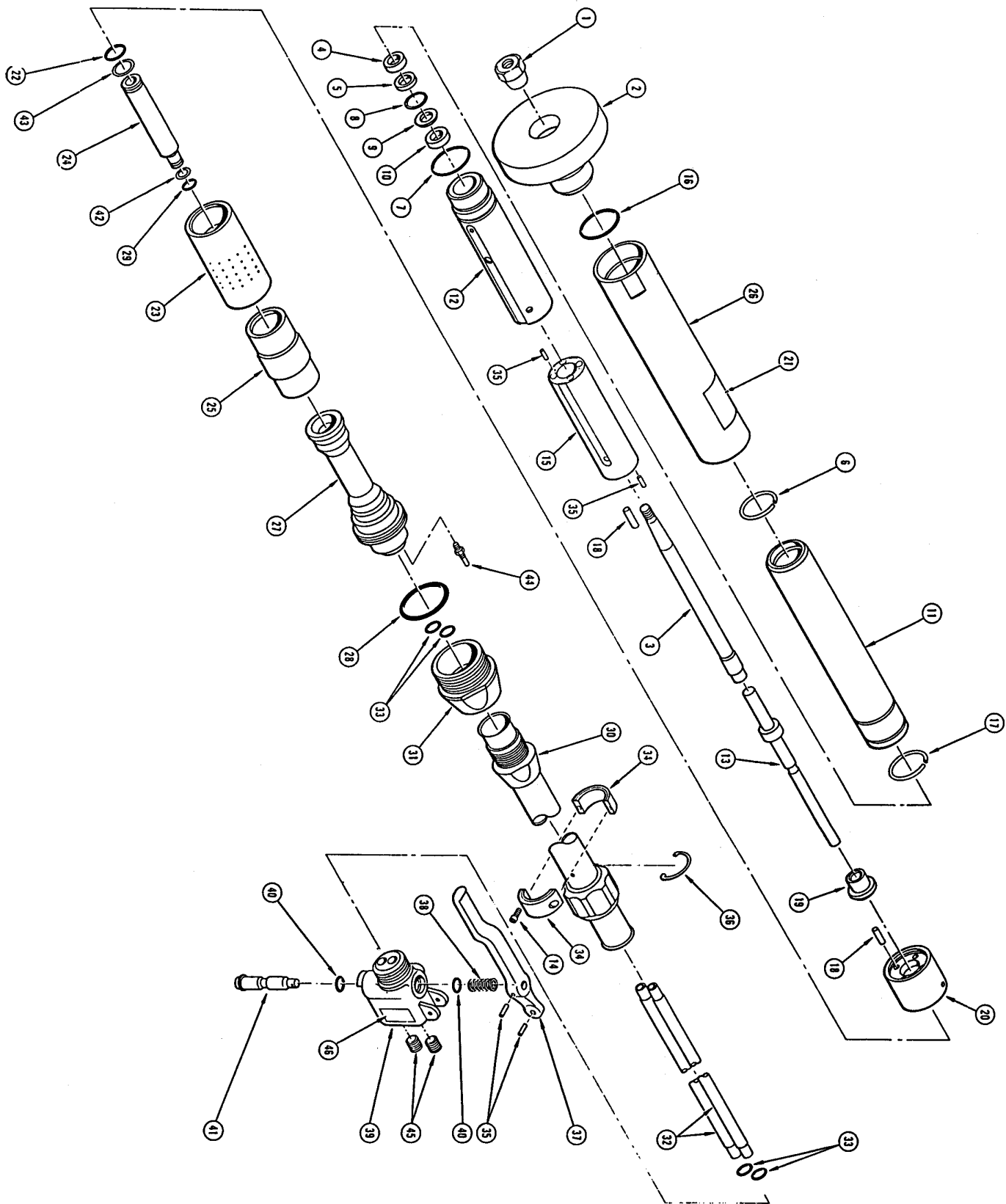

PARTS LIST

Item No.	Part No.	Qty.	Description
1	07300	1	Taper Nut
2	07428	1	Shoe/Insert Assy
3	07311	1	Piston
4	06524	1	Rod Wiper ☉
5	06534	1	Felt Wiper ☉
6	07296	1	Retaining Ring
7	07323	1	O-Ring, 1-7/8 x 2-1/16 x 3/32 ☉
8	07324	1	Retaining Ring, Spirolox #RRN-137
9	07297	1	Seal Washer
10	06527	1	Cup Seal, Disogrin #001-057 ☉
11	07312	1	Flow Sleeve Tube
12	07320	1	Flow Sleeve
13	07306	1	Push Rod
14	07407	2	Capscrew 10-32 x 3/4 Hex Soc Button Hd
15	07321	1	Automatic Valve Body
16	07325	1	O-Ring, 2-1/2 x 2-11/16 x 3/32 ☉
17	07301	1	Retaining Ring
18	04605	6	Push Pin
19	07308	1	Automatic Valve
20	07314	1	Porting Block
21	07333	1	Name Tag
22	01772	1	O-Ring, 3/4 x 7/8 x 1/16 ☉
23	07309	1	Accumulator Cylinder
24	07307	1	Push Rod Tube
25	06450	1	Accumulator Diaphragm
26	07313	1	Outer Cylinder
27	07315	1	Accumulator Chamber
28	07326	1	O-Ring, 2-7/16 x 2-5/8 x 3/32 ☉
29	07327	1	O-Ring, 5/16 x 7/16 x 1/16 ☉
30	08028	1	Handle Assembly - 1 ft.
	07310	1	Handle Assembly - 2 ft.
31	07303	1	Tube Nut
32	08027	1	Oil Tube - 1 ft.
	07304	1	Oil Tube - 2 ft.
33	07328	4	O-Ring, 1/2 x 5/8 x 1/16 ☉
34	07305	2	Hand Guard
35	00114	4	Roll Pin, 5/32 x 1
36	04533	1	Bail
37	04525	1	Trigger
38	04097	1	Spring
39	07319	1	Valve Body
40	07627	2	O-Ring, 5/8 x 3/4 x 1/6 ☉
41	04480	1	Valve Spool Assembly
42	07329	1	Back-Up Ring, Parker #8-011 N300-9 ☉
43	06988	1	Back-Up Ring, Parker #8-018 N300-9 ☉
44	07331	1	Charge Valve, Schrader #645-1 Stem w/#2300H Core
45	01212	2	Pipe Plug, 3/8 NPT
46	07334	1	Serial Number Plate
47	06345	2	Plastic Shipping Plug (Not Illustrated)

NOTE: Use Part Name and Part Number when ordering.
☉ Denotes part in Seal Kit.

SEAL KIT DATA

Part No.	Qty.	Description
Seal Kit Part No. 07390		
07627	2	O-Ring
01772	1	O-Ring
06524	1	Rod Wiper
06527	1	Cup Seal
06534	1	Felt Wiper
06988	1	Back-Up Ring

Part No.	Qty.	Description
07323	1	O-Ring
07325	1	O-Ring
07326	1	O-Ring
07327	1	O-Ring
07328	1	O-Ring
07329	1	Back-Up Ring

STANLEY[®]

helps you do things right

Stanley Hydraulic Tools
Division of the Stanley Works
3810 S.E. Naef Road
Milwaukie, OR 97267-5698
Tel: (503) 659-5660
Fax: (503) 652-1780
Telex: 360771

Stanley Power Tools
Nelson Park
Cramlington
Northumberland,
NE 23 9 BL
England
Tel: (44) (670) 713399
Fax: (44) (670) 712701

Stanley Svenska AB
Box 1054
Datavagen 51
S-436 22 Askim, Sweden
Tel: (46) (31) 289774
Fax: (46) (31) 288099

Stanley Tools SPA
Via Trieste 1
22060 Figino Serenza (CO),
Italy
Tel: (39) (31) 785111
Fax: (39) (31) 781766

Stanley Hydraulic Tools Asia
PO Box 425
12 Gul Drive
Jurong Town
Singapore 9161
Tel: (65) 8620833
Fax: (65) 8610901
or (65) 8610901
Telex: RS23945 STANLEY