

IW12 HYDRAULIC IMPACT WRENCH



Safety, Operation and Maintenance Manual

Focused on performance™

STANLEY
helps you do things right

SAFETY PRECAUTIONS

Tool operators and maintenance personnel must always comply with the safety precautions given in this manual and on the stickers and tags attached to the tool and hose.

These safety precautions are given for your safety. Review them carefully before operating the tool and before performing maintenance or repairs.

Supervising personnel should develop additional precautions relating to the specific work area and local safety regulations. If so, place the added precautions in the space provided on page 3.

GENERAL SAFETY PRECAUTIONS

The IW12 Impact Wrench provides safe and dependable service if operated in accordance with the instructions given in this manual. Read and understand this manual and any stickers and tags attached to the tool and hose before operation. Failure to do so can result in personal injury or equipment damage.

- Operators must start in a work area without bystanders. Flying debris can cause serious injury.
- The operator must be familiar with all prohibited work areas such as excessive slopes and dangerous terrain conditions.
- Always wear safety equipment such as goggles, ear and head protection, and safety shoes when operating the tool.
- Do not operate the tool if it is damaged, improperly adjusted or not completely and correctly assembled.
- Do not overreach. Maintain proper footing and balance at all times.
- Do not inspect or clean the tool while the hydraulic power source is connected. Accidental engagement of the tool can cause serious injury.
- Always connect hoses to the tool hose couplers before energizing the hydraulic power source. Make sure all hose connections are tight.
- Establish a training program for all operators to ensure safe operation.
- Do not operate the tool unless thoroughly trained or under the supervision of an instructor.
- When working near electrical conductors, always assume that all conductors are energized and that insulation, clothing and hoses can conduct electricity. Use hose labeled and certified as non-conductive.
- Do not operate the tool at fluid temperatures above 140°F/60°C. Operation at higher temperatures can cause higher than normal temperatures at the tool which can result in operator discomfort.
- Never wear loose clothing that can get entangled in the working parts of the tool.
- To avoid personal injury or equipment damage, all tool repair, maintenance and service must only be performed by authorized and properly trained personnel.

TOOL STICKERS AND TAGS

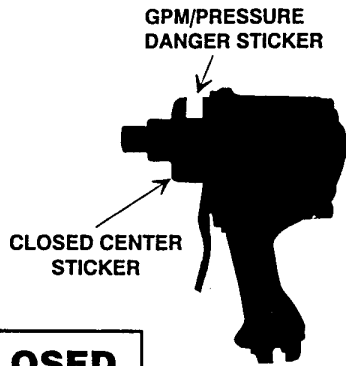

CLOSED CENTER
FOR USE ON
CLOSED CENTER
HYDRAULIC SYSTEM

CLOSED CENTER
STICKER

The stickers and tags attached to the wrench prior to shipment from the factory are shown below. The pressures and flow rates specified must never be exceeded. All stickers and tags must be read and understood prior to operation of the tool.

The information listed on stickers and tags must be legible at all times. Always replace stickers that have become worn or damaged. They are available from your local Stanley distributor.

DANGER	
<p>ELECTROCUTION HAZARD</p>	<p>Failure to use hydraulic hose labeled and certified as non-conductive when using hydraulic tools on or near electric lines may result in death or serious injury.</p> <p>For proper and safe operation read owners manual and make sure that you have been properly trained in correct procedures required to work on or around electric lines.</p>
<p>4-12 GPM/15-45 LPM DO NOT EXCEED 2000 PSI/140 BAR</p> <p>■ DO NOT EXCEED SPECIFIED FLOW OR PRESSURE. ■ USE CLOSED-CENTER TOOL ON CLOSED-CENTER SYSTEM. ■ USE OPEN-CENTER TOOL ON OPEN-CENTER SYSTEM. ■ CORRECTLY CONNECT HOSE TO TOOL "IN" AND "OUT" PORTS. ■ IMPROPER HANDLING, USE OR MAINTENANCE OF TOOL COULD RESULT IN A LEAK, BURST OR OTHER TOOL FAILURE. ■ CONTACT AT A LEAK OR BURST CAN CAUSE OIL INJECTIONS INTO THE BODY. ■ FAILURE TO OBSERVE THESE PRECAUTIONS CAN RESULT IN SERIOUS PERSONAL INJURY.</p>	

GPM/PRESSURE DANGER STICKER

SAFETY TAGS

The safety tag at right is attached to the wrench when shipped from the factory. Read and understand the safety instructions listed on this tag before removal. We suggest you retain this tag and attach it to the wrench when not in use.

DANGER
<p>DO NOT USE THIS WRENCH CONNECTED TO THE HYDRAULIC SYSTEM IN REVERSE. REVERSING CONNECTIONS WILL CAUSE REVERSE HYDRAULIC FLOW THROUGH THE TOOL WHICH MAY RESULT IN A LEAK OR BURST.</p> <p>CONTINUED USE OF THIS TOOL WITH REVERSED HYDRAULIC CONNECTIONS CAN CAUSE FATIGUE IN TOOL SEALS AND COMPONENTS WHICH MAY CAUSE A LEAK OR BURST.</p> <p>A HYDRAULIC LEAK OR BURST MAY CAUSE OIL INJECTION INTO YOUR BODY OR CAUSE OTHER SERIOUS PERSONAL INJURY.</p> <p style="text-align: right;">17936</p>

DANGER
<ol style="list-style-type: none"> FAILURE TO USE HYDRAULIC HOSE LABELED AND CERTIFIED AS NON-CONDUCTIVE WHEN USING HYDRAULIC TOOLS ON OR NEAR ELECTRICAL LINES MAY RESULT IN DEATH OR SERIOUS INJURY. BEFORE USING HOSE LABELED AND CERTIFIED AS NON-CONDUCTIVE ON OR NEAR ELECTRICAL LINES BE SURE THE HOSE IS MAINTAINED AS NON-CONDUCTIVE. THE HOSE SHOULD BE REGULARLY TESTED FOR ELECTRIC CURRENT LEAKAGE IN ACCORDANCE WITH YOUR SAFETY DEPARTMENT INSTRUCTIONS. A HYDRAULIC LEAK OR BURST MAY CAUSE OIL INJECTION INTO THE BODY OR CAUSE OTHER SEVERE PERSONAL INJURY. <ol style="list-style-type: none"> DO NOT EXCEED SPECIFIED FLOW AND PRESSURE FOR THIS TOOL. EXCESS FLOW OR PRESSURE MAY CAUSE A LEAK OR BURST. DO NOT EXCEED RATED WORKING PRESSURE OF HYDRAULIC HOSE USED WITH THIS TOOL. EXCESS PRESSURE MAY CAUSE A LEAK OR BURST. CHECK TOOL HOSE COUPLERS AND CONNECTORS DAILY FOR LEAKS. DO NOT FEEL FOR LEAKS WITH YOUR HANDS. CONTACT WITH A LEAK MAY RESULT IN SEVERE PERSONAL INJURY.
IMPORTANT
<p>READ OPERATION MANUAL AND SAFETY INSTRUCTIONS FOR THIS TOOL BEFORE USING IT.</p> <p>USE ONLY PARTS AND REPAIR PROCEDURES APPROVED BY STANLEY AND DESCRIBED IN THE OPERATION MANUAL.</p> <p>TAG TO BE REMOVED ONLY BY TOOL OPERATOR.</p> <p style="text-align: center;">SEE OTHER SIDE 15875</p>

DANGER
<ol style="list-style-type: none"> DO NOT LIFT OR CARRY TOOL BY THE HOSES. DO NOT ABUSE HOSE. DO NOT USE KINKED, TORN OR DAMAGED HOSE. MAKE SURE HYDRAULIC HOSES ARE PROPERLY CONNECTED TO THE TOOL BEFORE PRESSURIZING SYSTEM. SYSTEM PRESSURE HOSE MUST ALWAYS BE CONNECTED TO TOOL "IN" PORT. SYSTEM RETURN HOSE MUST ALWAYS BE CONNECTED TO TOOL "OUT" PORT. REVERSING CONNECTIONS MAY CAUSE REVERSE TOOL OPERATION WHICH CAN RESULT IN SEVERE PERSONAL INJURY. DO NOT CONNECT CLOSED-CENTER TOOLS TO OPEN-CENTER HYDRAULIC SYSTEMS. THIS MAY RESULT IN LOSS OF OTHER HYDRAULIC FUNCTIONS POWERED BY THE SAME SYSTEM AND/OR SEVERE PERSONAL INJURY. DO NOT CONNECT OPEN-CENTER TOOLS TO CLOSED-CENTER HYDRAULIC SYSTEMS. THIS MAY CAUSE EXTREME SYSTEM HEAT AND/OR SEVERE PERSONAL INJURY. BYSTANDERS MAY BE INJURED IN YOUR WORK AREA. KEEP BYSTANDERS CLEAR OF YOUR WORK AREA. WEAR HEARING, EYE, FOOT, HAND AND HEAD PROTECTION. TO AVOID PERSONAL INJURY OR EQUIPMENT DAMAGE, ALL TOOL REPAIR, MAINTENANCE AND SERVICE MUST ONLY BE PERFORMED BY AUTHORIZED AND PROPERLY TRAINED PERSONNEL.
IMPORTANT
<p>READ OPERATION MANUAL AND SAFETY INSTRUCTIONS FOR THIS TOOL BEFORE USING IT.</p> <p>USE ONLY PARTS AND REPAIR PROCEDURES APPROVED BY STANLEY AND DESCRIBED IN THE OPERATION MANUAL.</p> <p>TAG TO BE REMOVED ONLY BY TOOL OPERATOR.</p> <p style="text-align: center;">SEE OTHER SIDE 15875</p>

EQUIPMENT PROTECTION AND CARE

IMPORTANT

In addition to the Safety Precautions on pages 1 thru 3 of this manual, observe the following for equipment protection and care.

- Always use sockets and accessories designed for impact type applications. **DO NOT USE STANDARD SOCKETS OR ACCESSORIES. THESE CAN CRACK OR FRACTURE DURING OPERATION.**
- Always store the tool in a clean, dry space, safe from damage or pilferage.
- Always keep critical tool markings, such as labels and stickers, legible.
- Always replace hoses, couplings, and other parts with replacement parts recommended by Stanley Hydraulic Tools. Supply hoses must have a minimum working pressure rating of 2500 psi/175 bar.
- Always use hoses that have a fluid resistant inner surface and an abrasive resistant outer surface. Whenever near electrical conductors, use **clean** hose labeled and certified non-conductive.
- Make sure all couplers are wiped clean before connection.
- The hydraulic circuit control valve must be in the "OFF" position when coupling or uncoupling hydraulic tools. Failure to do so can result in damage to the quick couplers and cause overheating of the hydraulic system.
- Do not exceed 12 gpm/45 lpm flow rate. Rapid failure of the impact mechanism can result.
- Make sure the circuit **PRESSURE** hose (with male quick disconnect) is connected to the port furthest from the trigger. The circuit **RETURN** hose (with female quick disconnect) is connected to the port closest to the trigger.
- **Do not reverse circuit flow.** The reversing spool that is part of the tool provides for reverse operation of the wrench. Operation with circuit flow reversed causes rapid failure of the motor shaft seal and can break the impact mechanism. **ALWAYS USE THE REVERSING SPOOL BUILT INTO THE WRENCH FOR REVERSE OPERATION.**

HYDRAULIC HOSE REQUIREMENTS

HOSE TYPES

Hydraulic hose types authorized for use with Stanley Hydraulic Tools are as follows:

- ① Labeled and certified non-conductive
- ② Wire braided (conductive)
- ③ Fabric braided (not certified or labeled non-conductive)

Hose ① listed above is the only hose authorized for use near electrical conductors.

Hoses ② and ③ listed above are **conductive** and **must never** be used near electrical conductors.

To help ensure your safety, the following DANGER tags are attached to all hoses purchased from Stanley Hydraulic Tools. **DO NOT REMOVE THESE TAGS.**

If the information on a tag is illegible because of wear or damage, replace the tag immediately. A new tag can be obtained at no charge from your Stanley distributor.

① CERTIFIED NON-CONDUCTIVE HOSE

This tag is attached to all certified and labeled non-conductive hose.

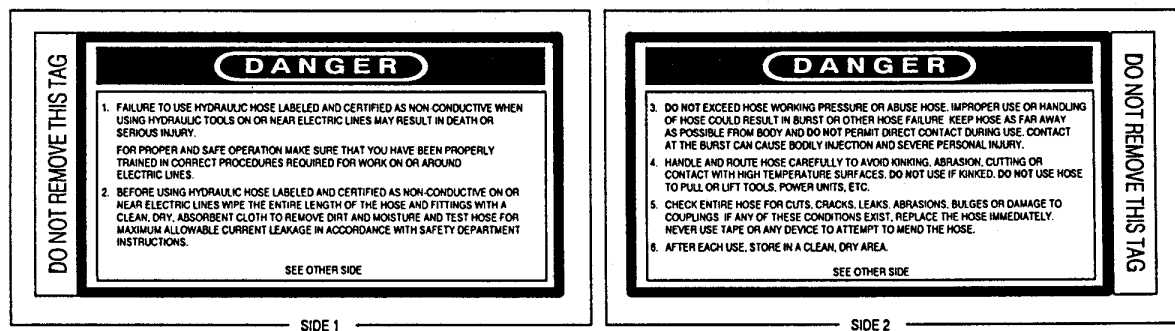

② AND ③ WIRE- AND FABRIC-BRAIDED (NOT CERTIFIED OR LABELED NON-CONDUCTIVE)

This tag is attached to all conductive hose.

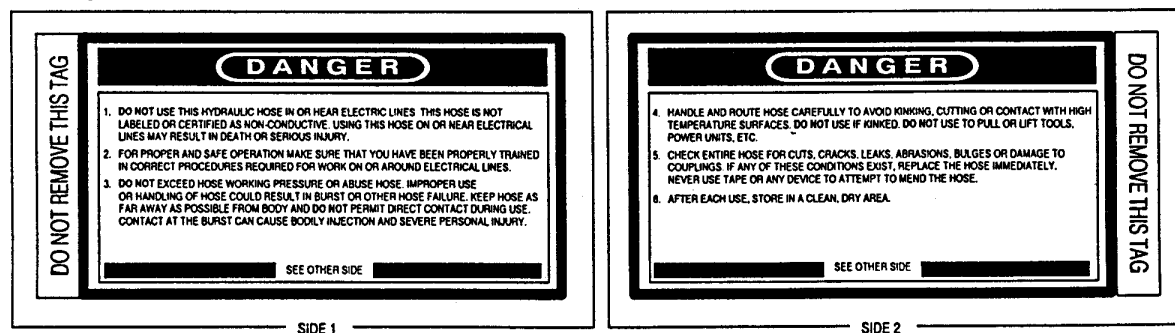

HOSE PRESSURE RATING

The rated working pressure of the hydraulic hose must be equal to or higher than the relief valve setting on the hydraulic system used to power the impact wrench.

HYDRAULIC SYSTEM REQUIREMENTS

- The hydraulic system should provide a flow of 4-12 gpm/15-45 lpm at an operating pressure of 1000-2000 psi/70-140 bar. Recommended relief valve setting is 2100 psi/145 bar.
- The system should not have more than 250 psi/17 bar backpressure measured at the tool end of the operating hoses. The system conditions for measurement are at maximum fluid viscosity of 400 ssu/82 centistokes (minimum operating temperatures).
- The hydraulic system should have sufficient heat rejection capacity to limit the maximum oil temperature to 140°F/60°C at the maximum expected ambient temperature. The recommended minimum cooling capacity is 5 hp/3.73 kW at a 40°F/4°C difference between ambient temperature and fluid temperature.
- The hydraulic system should have a minimum of 25 micron full-flow filtration. It is recommended that filter elements be sized for a flow of at least 30 gpm/114 lpm for cold temperature startup and maximum dirt holding capacity.
- The hydraulic fluid used should have a viscosity between 100 and 400 ssu/20 and 82 centistokes at the maximum and minimum expected operating temperatures. Hydraulic fluids of petroleum base with antiwear and non-conductive properties and viscosity indexes over 140 meet the recommended requirements over a wide range of operating temperatures.
- The recommended hose size is 0.500-inch/12 mm I.D. to 50 ft/15 m long and 0.625-inch/16 mm I.D. minimum up to 100 ft/30 m long.
- The wrench return hose must connect directly to the circuit return line and go straight through the fluid filter, thermal valve, and fluid cooler to the reservoir. To prevent trapped or reversed pressure, fluid should not be returned through a blocking or reversing valve.
- Do not use emulsifying hydraulic fluids and keep the recommended fluids drained of settled moisture. Water in the fluid can cause pump cavitation.
- The impact wrench must not be operated with the hydraulic flow reversed: Supply (IN) and return (OUT) hoses must be connected as marked on the tool. Forward and reverse operation of the tool is selected with the reversing spool located on the side of the wrench.

OPERATION

WRENCH TORQUE INFORMATION

FACTORS THAT AFFECT TORQUE

An impact wrench is a rotary hammer that impacts the head of a bolt or nut. It does not apply a slow steady torque as do standard torque wrenches. Therefore, several factors can affect resultant torque when using impact wrenches:

1. **Long bolts.** Long bolts, having high-friction threads with lubrication under the bolt head or associated nut, can twist when impacted, then untwist before the next impact, especially if there is low friction between the bolt head or nut and the mating surface.
2. **Heavy, loose or multiple adapters.** Heavy, loose or multiple adapters between the wrench and socket can dissipate the intensity of the impact to the bolt head or nut.
3. **Amount of impact.** Maximum resultant torque can be obtained by allowing continuous impacting of the socket against the bolt head or nut for at least 10 seconds.
4. **Hydraulic flow rate.** If the flow rate to the tool is too low, hammer (or impact) speed is reduced. If the flow is correct, a change in the relief pressure does not affect the impact force. Poorly designed hydraulic circuits can result in lower flow rates and reduced impact speeds when pressure is required during impacting.

BOLT GRADE AND THREAD RECOMMENDATIONS

Allowable bolt torque is limited by both bolt thread diameter and grade of steel in the bolt. The IW12 Impact Wrench is recommended for use on the following bolt grade and thread sizes:

SAE Grade 2	1-11/2 inch/25-38 mm
SAE Grade 5	3/4-11/4 inch/19-32 mm
SAE Grade 8	5/8-1 inch/16-25 mm

PREOPERATION PROCEDURES

CHECK POWER SOURCE

1. Using a calibrated flowmeter and pressure gauge, check that the hydraulic power source develops a flow of 4-12 gpm/15-45 lpm at 1000-2000 psi/70-140 bar.
2. Make certain that the hydraulic power source is equipped with a relief valve set to open at 2100 psi/145 bar, minimum.

CONNECT HOSES

1. Wipe all hose couplers with a clean lint-free cloth before making connections.
2. Connect the hoses from the hydraulic power source to the tool fittings or quick disconnects. It is a good practice to connect the return hose first and disconnect it last to minimize or eliminate trapped pressure within the wrench.
3. Observe the flow indicators stamped on the main body assembly and the hose couplers to ensure that the flow is in the proper directions. The female coupler on the tool's "IN" port is the inlet (pressure) coupler.

Note: If uncoupled hoses are left in the sun, pressure increase within the hoses can make them difficult to connect. Whenever possible, connect the free ends of hoses together.

WRENCH OPERATION

- The IW12 Impact Wrench is designed for 3/4-inch square sockets and accessories. Adapter part number 06790 or equivalent will permit the use of 5/8-inch quick change drive attachment.
 - Normal applications include installation or removal of fasteners requiring torque in the range of 300-1200 ft lb/407-1627 Nm and auger bit wood boring. DO NOT use the wrench as a hammer drill or for metal drilling.
 - During normal operation it is common to see some grease leakage from around the anvil during hard use. See the SERVICE INSTRUCTIONS section of this manual for the correct lubrication procedures.
1. Observe all safety precautions.
 2. Move the hydraulic circuit control valve to the "ON" position to operate the wrench.

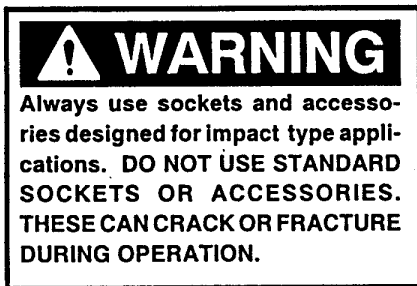

3. Select the direction of impact desired using the rotary reversing valve located on the left side of the wrench. To select clockwise direction, move the lever toward the front (drive end) of the wrench. To select counterclockwise direction, move the lever to the rear (handle end) of the wrench.

Note: To more accurately tighten bolts, lubricate threads, check with a torque wrench and duplicate time of impacting for other bolts of the same length and thread size.

4. Squeeze the trigger to activate the wrench.
5. Release the trigger to stop the wrench.

COLD WEATHER OPERATION

If the wrench is to be used during cold weather, preheat the hydraulic fluid at low engine speed. When using the normally recommended fluids, fluid temperature should be at or above 50° F/10° C (400 ssu/82 centistokes) before use.

Damage to the hydraulic system or wrench can result from use with fluid that is too viscous or too thick.

POST-OPERATION

UNDERWATER MODELS ONLY. The wrench impact mechanism must be cleaned and greased with waterproof grease after each day's use. The main housing valve sand motor are sealed and do not require maintenance unless they are malfunctioning.

Remove, clean, grease and assemble the impact mechanism as described in the SERVICE INSTRUCTIONS section of this manual.

SERVICE INSTRUCTIONS

Good maintenance practice keeps the wrench on the job and increases its service life.

The most important maintenance practice is to keep the hydraulic fluid clean at all times. Contaminated hydraulic fluid causes rapid wear and/or failure of internal parts.

Follow the procedures contained in the HYDRAULIC SYSTEM REQUIREMENTS section of this manual to ensure peak performance from the tool.

Never disassemble the main housing unless proper troubleshooting procedures have isolated the problem to an internal part. Then, disassemble the tool only to the extent necessary to replace the defective part. KEEP CONTAMINANTS SUCH AS DIRT AND GRIT AWAY FROM INTERNAL PARTS AT ALL TIMES.

Always determine and correct the cause of the problem prior to reassembly. Further wear and tool failure can result if the original cause is not corrected.

IMPORTANT

The impact mechanism is subject to grease "squeeze out", impact heat accumulation, centrifugal force throwing the grease away from moving parts, and an expansion pressure pushing lubricant out of the anvil bushing. Maintenance intervals vary with daily cycles, impact energy intensity and lubricant quality. It is very important that an inspection schedule be established to ensure that parts inside the mechanism are well lubricated. Be sure to remove any grease that appears to be burned. Make sure grease is packed around all parts.

PRIOR TO DISASSEMBLY

- Clean the exterior of the tool.
- Obtain Impact Grease part number 02718 for land models or Waterproof Impact Grease part number 03201 for underwater models.
- Obtain Seal Kit part number 08073 or 13695 so all seals exposed during disassembly can be replaced during reassembly.

PRIOR TO REASSEMBLY

- Clean all parts with a degreasing solvent.
- Ensure that all seals exposed during disassembly are replaced with new parts.
- Apply clean grease or o-ring lubricant to all parts during assembly.

Note: For parts orientation, see the PARTS LIST section of this manual.

IMPACT MECHANISM REMOVAL, CLEANING AND INSTALLATION

REMOVAL

1. Remove the four 5/16-18 x 7/8-inch/22 mm long socket head capscrews and lockwashers securing the hammer case assembly to the main body assembly.

Note: Some wrenches use four 5/16-18 x 3/4-inch/19 mm long socket head capscrews without lockwashers. Replace these capscrews with 5/16-18 x 7/8-inch/22 mm long socket head capscrews and lockwashers.

2. On underwater models, loosen and remove the 10-24 x 1-3/4-inch/44 mm long socket head cap screw and locknut (or Spirol pin) securing the lower end of the trigger guard to the main housing assembly and swing the trigger guard away.

3. Hold the wrench with impact mechanism pointing down and depress the trigger while pulling the hammer case, gasket and impact mechanism away from housing assembly.

4. Remove the thrust bearing and two thrust races, if they were not removed with the impact mechanism.

5. Turn the hammer case (anvil up). The impact mechanism components will drop into your hand.

6. Remove two hammer pins from the hammer frame. The hammer and anvil can be removed at this time.

INSTALLATION

1. Thoroughly clean all parts of the mechanism
2. Using the correct Impact Grease part number 02718 for land models or Waterproof Impact Grease part number 03201 for underwater model, lubricate the inside of the hammer frame and install the hammer, anvil and two hammer pins. The inside of the hammer case should be free of grease to avoid over-lubrication.
3. Lubricate the hammer case bushing and slide onto the anvil.
4. Grease the thrust bearing and thrust races. Install thrust race, thrust bearing and remaining thrust race on the main shaft in that order.
5. Install a new hammer case gasket (or o-ring). (On underwater models, lubricate and install the o-ring in the hammer case bushing bore). Slide the hammer case assembly onto the anvil and secure with four 5/16-18 x 7/8-inch/22 mm long socket capscrews and lock-washers. Tighten to a torque of 13-15 ft lb/17.6-20.3 Nm.
6. On underwater models, secure the lower trigger guard to the main housing using the 10-24 x 1-3/4-inch/44 mm long socket head cap screw and locknut.

WRENCH DISASSEMBLY AND REASSEMBLY FOR REPAIR

MOTOR DISASSEMBLY

1. Remove the impact mechanism as described in the IMPACT MECHANISM REMOVAL AND INSTALLATION section of this manual.
2. Remove the eight 3/8-16 x 1-3/4-inch/44 mm long socket head capscrews and lockwashers securing the motor cap assembly to the main housing.
3. With the wrench handle gripped in a vise, press on the splined end of the main shaft with one hand and support the motor cap assembly with the other. Press the motor cap assembly, gears and o-ring out of the main housing. DO NOT pry or in any way excessively force the motor cap assembly off of the main housing.
4. Remove the large o-ring from the motor cap assembly.
5. Remove the idler gear, idler shaft and main shaft.

6. If the relief adjustment screw o-ring requires replacement, loosen the jam nut and remove the relief adjustment screw. Be sure to count the number of turns required to remove it so it can be replaced in the same position. Refer to IMPACT ADJUSTMENT section of this manual.

MOTOR CLEANING AND INSPECTION

Cleaning

Clean all parts with a degreasing solvent. Blow dry with compressed air and wipe clean. Use only lint-free cloths.

Bushings (Main Housing and Motor Cap)

The inside of the bushings should be gray in color. If a significant amount of yellow-bronze shows, bushing replacement is required. Inspect shafts for corresponding wear and replace as required.

Gear Chamber (Motor Cap)

The gear chamber bores and end faces around the bores should be polished, not rough or grooved. The flat surfaces around the chamber and bolt holes should be flat and free of nicks and burrs that could cause misalignment or leaks.

Gears

Both gears should have flat, straight tips without nicks. They should have smooth even polish on the teeth and end faces. Discard the gear if cracks are present.

Main Housing Assembly

The gear running surfaces should show two interconnecting polished circles without a step or roughness.

IMPORTANT

If abnormal wear occurs in excess of normal polishing, both shafts and associated bushings must be replaced. The hydraulic system should be thoroughly flushed and the filter replaced before further operation of the wrench.

Shafts

The main diameter at the bushing locations must be smooth. Grooves, roughness or a reduced diameter indicates fluid contamination and damaged bushings.

MAIN HOUSING DISASSEMBLY

Note: See the PARTS LIST section of this manual for orientation of parts in the main housing assembly.

1. Remove the 1/4-20 x 1/4-inch/6 mm long internal hex set screw securing the reversing spool lever and remove the lever from the reversing spool.
2. Remove the retaining ring at the opposite end of the reversing spool.
3. Pressing on the retaining ring end of the reversing spool, carefully slide the reversing spool in just far enough to gain access to the back-up ring and o-ring on the lever side. Remove the back-up ring and o-ring with the appropriate o-ring tool.
4. Pressing on the lever end of the reversing spool, carefully slide the reversing spool out of the main housing. Remove the back-up ring and o-ring with the appropriate o-ring tool.
5. Remove the 10-24 x 1 3/4-inch/44 mm long socket head capscrew and locknut (or Spirol pin) securing the trigger to the trigger pivot. Remove the trigger.
6. Pull the needle roller from the spool cap, or unscrew the spool cap and remove the headed push pin. Remove the o-rings and wiper.
7. Slide the valve spool, relief seat, relief poppet, spring rest and two springs out of the main housing. See the PARTS LIST section of this manual for clarification if required. If the valve sleeve requires replacement, the main housing should be returned to Stanley for repair.

Note: The valve sleeve will remain in the main housing. It is not removable.

Note: There is only a small visual difference between the valve spool used for o.c. or c.c. wrenches. DO NOT confuse them when reassembling the wrench. An o.c. spool has outer ring widths of less than 0.3-inches/7 mm while c.c. spools have outer ring widths of over 0.4-inches/ 10 mm.

8. Remove the retaining ring at the impact mechanism end of the main housing. Remove the back-up washer and o-ring. The o-ring is subject to severe service and should be replaced whenever the main shaft is serviced.

MAIN HOUSING ASSEMBLY

1. Lubricate and install the relief seat in the valve spool (notched end aligned with strut), followed by the relief poppet, small spring and spring seat (see parts location illustration for correct orientation of spring seat).
2. Set the large spring on the open end of the reversing spool.
3. Hold the wrench so the trigger portion faces downward. Slide the components assembled above into the main housing.
4. Lubricate and install the two o-rings and wiper on the spool cap. Insert the headed push pin into the spool cap.
5. Screw the spool cap into the main housing. Tighten securely.
6. Install the trigger using the 10-24 x 1 3/4-inch/44 mm long socket head capscrew and locknut (or Spirol pin).

MOTOR ASSEMBLY

1. Lubricate and install o-ring in the relief adjustment screw bore in the motor cap.
2. Install the relief adjustment screw with jam nut positioned near the screw head. Install with the same number of turns counted when disassembled to maintain the correct impact force. Tighten jam nut. Refer to IMPACT ADJUSTMENT section in this manual.
3. Install the main shaft, idler gear and idler shaft in the motor cap.
4. Lubricate and install the large o-ring in groove of the motor cap.
5. Carefully slide the main housing over the main shaft until it seats securely against the motor cap.
6. Lubricate and install the eight 3/8-16 x 1 3/4-inch/44 mm long socket head capscrews and washers. Tighten to a torque of 22-25 ft lb/ 29.8-33.9 Nm.
7. Lubricate and install the o-ring on the main shaft. Install the back-up ring, back-up washer and retaining ring.
8. Grease the thrust bearing and thrust washers and install on the main shaft. Install the hammer case gasket (or o-ring) and replace the mechanism. (See parts location illustration for thrust bearing part sequence.)

9. Install the four 5/16-18 x 7/8-inch/22 mm long socket head capscrews and lockwashers. Tighten to a torque of 13-15 ft lb/17.6-20.3 Nm.

10. Lubricate and install the o-ring and back-up ring (o-ring toward center; then back-up ring toward end) on the retaining ring end of the reversing spool.

11. Slide the reversing spool into the main housing from the right side (as the wrench is held during operation). Install only far enough to install the o-ring and back-up ring on the lever side of the reversing spool with the back-up ring toward the end.

12. Center the reversing spool and install the retaining ring.

13. Turn the reversing spool so the hole will be pointing up. Align the hole in the lever with hole in the reversing spool and install the lever. Secure with the 1/4-20 x 1/4-inch/6 mm long internal hex set screw. Tighten the set screw securely.

IMPACT INTENSITY ADJUSTMENT

- When shipped from Stanley, the wrench has been set to produce approximately 800-1000 ft lb/ 1085-1356 Nm torque. **The adjustment is made using 8 gpm/30 lpm input flow to tighten a lubricated 2 3/4-inch thread Skidmore standard bolt tension tester.**
- At hydraulic flows over 8 gpm/30 lpm, power may exceed the mechanical capacity and cause mechanism discharge. Adjust for lower power for flows below 8 gpm/30 lpm. Increase the adjustment for more power.
- For other circuit flows, bolt types and torque requirements, the impact intensity can be adjusted by loosening the jam nut on the relief adjustment screw (on back of the motor cap, just above the handle) and turning the relief adjustment screw clockwise for more torque or counterclockwise for less torque.
- The IW12 is not a torque wrench. If the torque setting of a particular fastener type is critical, the wrench should be set as close to the desired torque as possible and a calibrated torque wrench used to verify or check the fastener torque periodically.

ADJUSTMENT

IMPORTANT

- Do not operate the wrench with relief adjustment screw turned in more than one turn from the bottom or less than three turns from the top of its travel.
- Never operate the wrench without securing the relief screw jam nut.

1. Determine the characteristics of the circuit that will be used to power the wrench. The hydraulic circuit and wrench should be at operating temperature. DO NOT exceed the maximum flow or pressure for the wrench.

2. Attach a flow and pressure tester to the pressure port of the impact wrench. Connect hoses normally and activate the hydraulic power supply.

3. If the power source is of unknown output, it is good practice to turn the relief adjustment screw counterclockwise (NO MORE THAN THREE TURNS FROM THE TOP OF ITS TRAVEL) to ensure that the operating pressure remains below 1500 psi/104 bar. Tighten the jam nut securely before operating the wrench.

4. Install the appropriate sockets/adapters to the impact wrench and tighten the bolt or fastener you wish to set the wrench for. Watch the flow and pressure tester to be certain that maximum flow and pressure are not being exceeded.

5. Check the fastener with a torque wrench to determine the actual torque being delivered by the impact wrench.

6. To increase the torque, turn the relief adjustment screw clockwise (NO MORE THAN ONE TURN FROM THE BOTTOM). To reduce the torque, turn the relief adjustment screw counter-clockwise (NO MORE THAN THREE TURNS FROM THE TOP OF ITS TRAVEL). Check the torque with a torque wrench.

7. When adjustment is complete, securely tighten the jam nut.

TROUBLESHOOTING

If symptoms of poor performance develop, the following chart can be used as a guide to correct the problem.

When diagnosing faults in operation of the wrench, always check that the hydraulic power source is

supplying the correct hydraulic flow and pressure to the tool as listed in the following table. Use a flowmeter known to be accurate. Check the flow with the hydraulic fluid temperature at least 80° F/ 27° C.

PROBLEM	CAUSE	REMEDY
Low performance or impact.	Incorrect hydraulic flow.	Check that hydraulic power source is producing 4-12 gpm/15-45 lpm at 1000-2000 psi/70-140 bar.
	Defective quick disconnects.	Check each quick disconnect.
	Worn impact mechanism.	Repair or replace the impact mechanism. See SERVICE Mechanism Removal Cleaning and Installation procedure to extend mechanism life..
	Hammer pins broken.	Replace with intergal frame (with pins). Check relief adjustment screw setting. Job may require a larger wrench.
	Incorrect grease or periodic maintenance of the impact mechanism is not being performed.	See SERVICE INSTRUCTIONS.
	Spools incorrectly installed.	Valve (s) incorrectly reassembled. See SERVICE INSTRUCTIONS.
	Sockets or adapters too heavy or loose.	Use the correct impact type sockets or adapters.
	Long bolt with lubricated head.	Lubricate threads only.
Wrench runs too fast; impact mechanism or screws broken.	Incorrect hydraulic flow (too high).	Check that hydraulic power source is producing 4-12 gpm/15-45 lpm at 1000-2000 psi/70-140 bar.
	Supply and return hoses reversed.	Install hoses correctly. Refer to OPERATION INSTRUCTIONS.
	Relief sleeve or spring damaged.	Remove and replace spool assembly.
	Adjusting screw is in too far.	Adjust correctly.
Grease leaks at anvil bushing, wrench warm.	Hard duty cycle and heat forces grease out.	Normal unless greasing instructions in SERVICE INSTRUCTIONS are not followed.
Grease leaks at anvil bushing, wrench cold.	Main shaft O-ring leaking.	Replace as required.

PROBLEM	CAUSE	REMEDY
Oil leak at motor cap face.	Fasteners loose.	Tighten to recommended torque.
	Face o-ring worn or missing.	Replace as required.
	Motor cap/main housing damaged.	Replace as required.
Oil leaks at reversing spool.	Damaged o-rings.	Replace as required. Check SERVICE INSTRUCTIONS to avoid cutting o-rings on cross holes in the spool bore.
	Wrong hydraulic fluid. Circuit too hot.	Refer to OPERATION INSTRUCTIONS for correct fluid/circuit specifications.

SPECIFICATIONS

Drive Size	3/4-inch Square Drive: 5/8-inch hex Quick-Change
Weight	14 lb/6 kg
Overall Length	9.5-inch/24 cm
Width	4-inch/10 cm
Pressure Range	1000-2000 psi/70-140 bar
Flow Range	4-12 gpm/15-45 lpm
Optimum Flow	5-10 gpm/20-38 lpm
System type	open and closed center, HTMA TYPE II or III
Porting	8 SAE O-Ring
Output Speed (Free Spin)	2000 rpm at 5 gpm/19 lpm
Input Speed	1200 impacts per minute
Connect Size and Type	3/8-inch male Pipe adapter
Torque	250-1200 ft lb/340-1632 Nm

NOTE

Weights, dimensions, and operating specifications listed are subject to change without notice. Where specifications are critical to your application, please consult the factory.

ACCESSORIES

PART NUMBER	DESCRIPTION
01857	3/4 in. Square Anvil to 3/4 in. Jacobs Chuck
02718	Impact Tool (Land Model) Lubricant (1 Pound Can)
03201	Impact Tool (Underwater) Lubricant (1 Pound Can)
05117	7/16 in. Hex Shank x 1/2 in. Square Male Adapter
05080	5/8 in. Hex shank x 1/2 in. Square Male Adapter
05082	5/8 in. Hex Shank x 1/2 in. Square Male Adapter
06790	3/4 in. Square Anvil to 5/8 in. Hex Quick-Change Adapter

Auger Drill Bits - Lineman's Style

5/8-in. Hex Shank - Use with Hex Adapter 06790

05020	Auger 9/16 in. x 12 in./30.5 cm
05021	Auger 9/16 in. x 18 in./45.7 cm
05022	Auger 9/16 in. x 24 in./61 cm
05023	Auger 11/16 in. x 12 in./30.5 cm
05024	Auger 11/16 in. x 18 in./45.7 cm
05025	Auger 11/16 in. x 24 in./61 cm
05026	Auger 13/16 in. x 12 in./30.5 cm
05027	Auger 13/16 in. x 18 in./45.7 cm
05028	Auger 13/16 in. x 24 in./61 cm
05029	Auger 15/16 in. x 18 in./45.7 cm
05030	Auger 15/16 in. x 24 in./61 cm
05031	Auger 17/16 in. x 24 in./61 cm
05032	Auger 17/16 in. x 24 in./61 cm

WARRANTY

Hand held tools and their parts are warranted against defects in materials and workmanship for a period of 12 months from the date of purchase. Exceptions are cutting parts, steels and other parts not manufactured by Stanley (such as impact mechanisms, alternators, regulators and hoses), and parts subject to normal wear and tear (such as o-rings, saw blades, and other parts that become worn through normal use of the tool).

The Warranty Registration Card packed with the tool must be filled out and returned to Stanley upon receipt of the tool.

Stanley reserves the right to replace or repair only those parts that, under our examination, prove to have been defective at the time of purchase.

Shipping charges are prepaid by the customer unless otherwise authorized by Stanley.

The warranty is void if maximum flow and pressure ratings are exceeded.

There is no other warranty expressed or implied.

SEAL KIT DATA

Land Model

Part No.	Qty.	Description
Seal Kit Part No. 08073		
06533	1	O-Ring
00026	1	O-Ring
01211	2	O-Ring
08015	2	Back-Up Ring
00717	1	O-Ring
08017	1	O-Ring
08023	1	O-Ring
08022	1	O-Ring
01605	2	Gasket
09396	1	Back-Up Ring
22064	1	Rod Wiper
00149	1	O-Ring

MODELS WITH STANDARD IMPACT MECHANISM

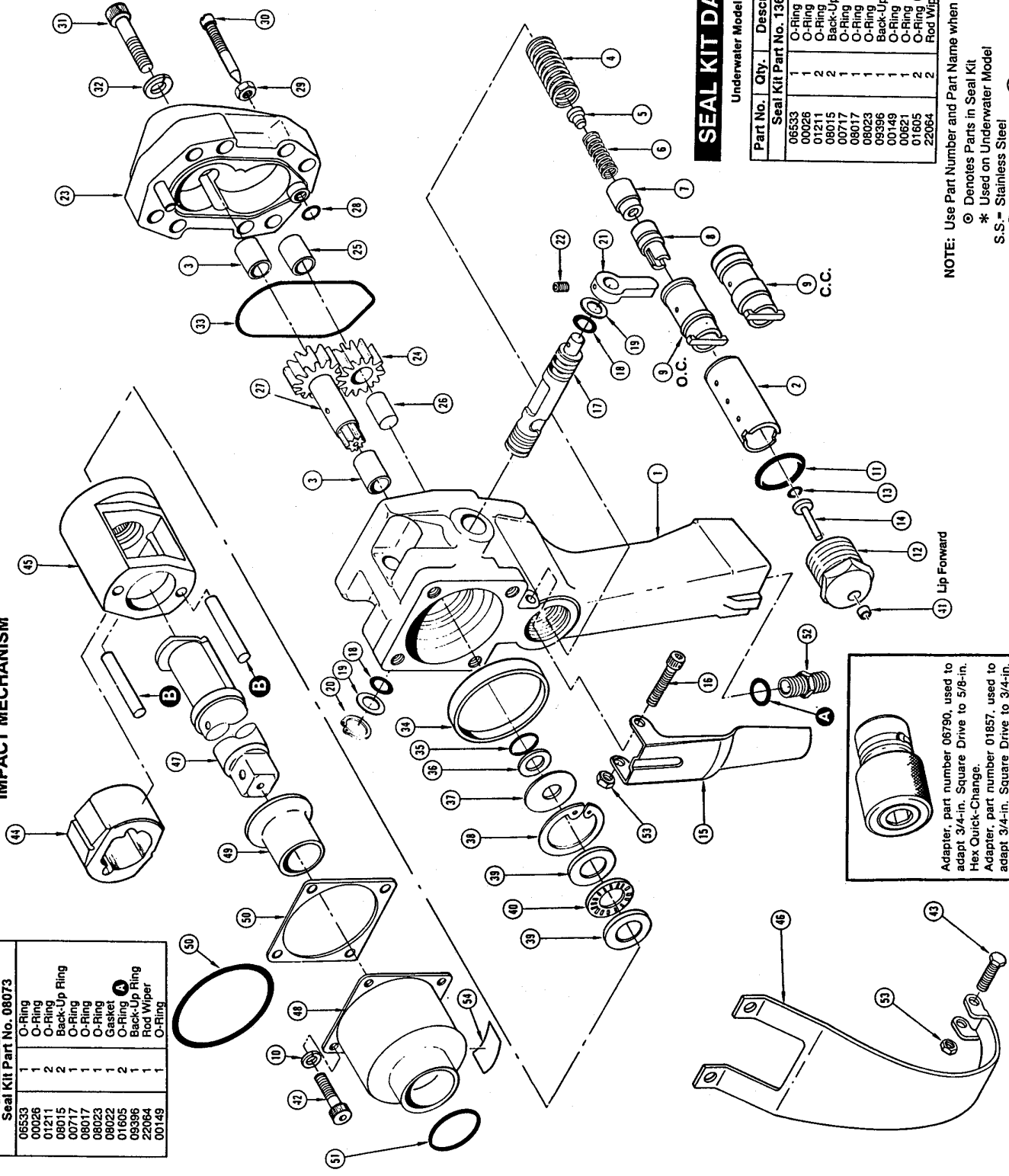

SEAL KIT DATA

Underwater Model

Part No.	Qty.	Description
Seal Kit Part No. 13695		
06533	1	O-Ring
00026	1	O-Ring
01211	2	O-Ring
08015	2	Back-Up Ring
00717	1	O-Ring
08017	1	O-Ring
08023	1	O-Ring
09396	1	Back-Up Ring
00149	1	O-Ring
00621	1	O-Ring
01605	2	O-Ring
22064	2	Rod Wiper

NOTE: Use Part Number and Part Name when ordering.
 Ⓞ Denotes Parts in Seal Kit
 * Used on Underwater Model
 S.S. = Stainless Steel
 Supplied with item 52
 Simplified with item 52

Adapter, part number 06790, used to adapt 3/4-in. Square Drive to 5/8-in. Hex Quick-Change.
 Adapter, part number 01857, used to adapt 3/4-in. Square Drive to 3/4-in. 3-Jaw Jacobs Chuck.

PARTS LIST

Item No.	Part No.	Qty.	Description
1	07999	1	Main Housing Assy
	12778	1	Main Housing Assy *
2	07994	1	Valve Sleeve
3	08014	2	Du Bushing - Garlock 14Du12
4	07988	1	Spring
5	07982	1	Spring Rest
6	07985	1	Spring
7	07993	1	Relief Poppet
8	07986	1	Relief Seat
9	07998	1	Valve Spool - Open Center
	09903	1	Valve Spool - Closed Center
10	00145	4	Lockwasher, 5/16
	00231	4	Lockwasher, 5/16 S.S. *
11	06533	1	O-Ring, 1.171 x 1.403 x .116 ⊙
12	22063	1	Spool Cap *
	08000	1	Spool Cap
13	00026	1	O-Ring, 3/16 x 5/16 x 1/16 ⊙
14	06634	1	Needle Roller, 3/16 x 1 Plated
	23678	1	Headed Push Pin *
15	07996	1	Trigger
	12283	1	Trigger *
16	00025	1	Capscrew, 10-24 x 1 3/4 Hex Soc Head
	00786	1	Capscrew, 10-24 x 1 3/4 Hex Soc Head S.S. *
17	08002	1	Reversing Spool
18	01211	2	O-Ring, 5/8 x 3/4 x 1/16 ⊙
19	08015	2	Back-Up Ring ⊙
20	08016	1	Retaining Ring .750 Ext.
	09275	1	Retaining Ring .750 Ext. S.S. *
21	04939	1	Lever
22	00720	1	Setscrew 1/4-20 x 3/8
	00580	1	Setscrew 1/4-20 x 1/4 S.S. *
23	07997	1	Motor Cap Assy (Incl. Item 3)
24	07989	1	Idler Gear Assy (Incl. Item 25)
25	07978	1	Idler Gear Bushing
26	07991	1	Idler Shaft
27	08001	1	Main Shaft
28	00717	1	O-Ring, 1/4 x 3/8 x 1/16 ⊙
29	00429	1	Nut, 5/16-18
	09277	1	Nut, 5/16-18 S.S. *
30	19453	1	Relief Adjustment Screw
31	00682	8	Capscrew - 3/8-16 x 1 3/4 Hex Soc Head
	01870	8	Capscrew - 3/8-16 x 1 3/4 Hex Soc Head S.S. *
32	01459	8	Lockwasher, 3/8
	00812	8	Lockwasher, 3/8 S.S. *
33	08023	1	O-Ring, 3.300 x 3.400 x .070 ⊙
34	07980	1	Pilot Ring
35	08017	1	O-Ring, 7/8 x 1 1/16 x 3/32 ⊙
36	09396	1	Back-Up Ring ⊙
37	07987	1	Back-Up Washer
38	00166	1	Retaining Ring
39	08019	2	Thrust Race
40	08020	1	Thrust Bearing
41	22064	1	Rod Wiper ⊙ *
42	02685	4	Capscrew, 5/15-18 x 7/8 Hex Soc Head
	10566	4	Capscrew, 5/15-18 x 7/8 Hex Soc Head S.S. *
43	12287	1	Capscrew, 10-24 x 1 Hex Soc Head S.S. * (Incl. Item 53)
44	08067	1	Hammer
45	19456	1	Hammer Frame Assy (Incl. Hammer Pins)
46	12285	1	Trigger Guard *
47	08070	1	Anvil - 3/4 Square Drive
	10881	1	Anvil - 3/4 Square Drive 12" Long
	12784	1	Anvil *
48	08071	1	Hammer Case Assy (Incl. Item 49)
	12785	1	Hammer Case Assy *
49	08072	1	Hammer Case Bushing
	13694	1	Hammer Case Bushing *
50	08022	1	Hammer Case Gasket ⊙
	00149	1	O-Ring, 3 1/4 x 3 3/8 x 1/16 042 R16 ⊙ *
51	00621	1	O-Ring ⊙ *
52	00936	2	Adapter, 1/2 SAE to 3/8 NPT Male
53	06971	2	Locknut, 10-24
54	03693	1	Sticker, Closed Center
	19457		Impact Mechanism - 3/4 Square Drive
	12783		Impact Mechanism, u/w - 3/4 Square Drive *
	10882		Impact Mechanism - 3/4 Square Drive - 12" Extd

SEAL KIT DATA

MODELS WITH
HEAVY DUTY
IMPACT MECHANISM

Part No.	Qty.	Description
Seal Kit Part No. 08073		
06533	1	O-Ring
00026	1	Quad Ring
01211	2	O-Ring
08015	2	Back-Up Ring
00717	1	O-Ring
08017	1	O-Ring
08023	1	O-Ring
01605	2	O-Ring A
09396	1	Back-Up Ring
00149	1	O-Ring
08022	1	Gasket
22064	1	Rod Wiper

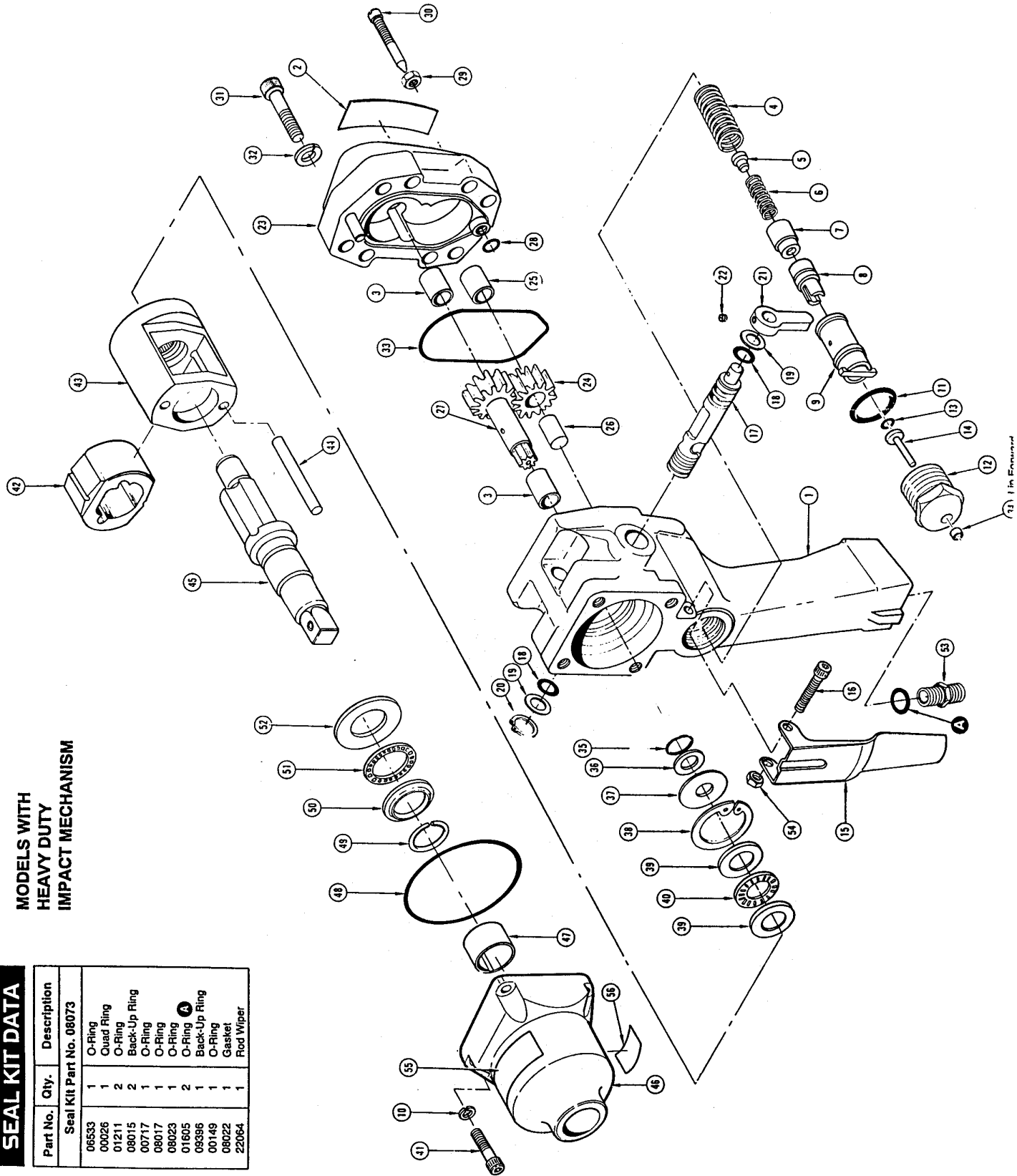

PARTS LIST

Item No.	Part No.	Qty.	Description
1	07999	1	Main Housing Assy
2	08012	1	Name Tag
3	08014	2	Du Bushing - Garlock 14Du12
4	07988	1	Spring
5	07982	1	Spring Rest
6	07985	1	Spring
7	07993	1	Relief Poppet
8	07986	1	Relief Seat
9	07998	1	Valve Spool - Open Center
10	00145	4	Lockwasher, 5/16
11	06533	1	O-Ring, 1.171 x 1.403 x 0.116 ⊙
12	22063	1	Spool Cap
13	00026	1	O-Ring, 3/16 x 5/16 x 1/16 ⊙
14	23678	1	Headed Push Pin
15	07996	1	Trigger
16	00025	1	Capscrew, 10-24 x 1 3/4 Hex Soc Head
17	08002	1	Reversing Spool
18	01211	2	O-Ring, 5/8 x 3/4 x 1/16 ⊙
19	08015	2	Back-Up Ring ⊙
20	08016	1	Retaining Ring, 0.750 Ext
21	04939	1	Lever
22	00720	1	Setscrew, 1/4-20 x 3/8
23	07997	1	Motor Cap Assy (Incl Item 3)
24	07989	1	Idler Gear Assy (Incl Item 25)
25	07978	1	Idler Gear Bushing
26	07991	1	Idler Shaft
27	08001	1	Main Shaft
28	00717	1	O-Ring, 1/4 x 3/8 x 1/16 ⊙
29	00429	1	Nut, 5/16-18
30	19453	1	Relief Adjustment Screw
31	00682	8	Capscrew, 3/8-16 x 1 3/4 Hex Soc Head
32	01459	8	Lockwasher, 3/8
33	08023	1	O-Ring, 3.300 x 3.400 x 0.070 ⊙
34	22064	1	Wiper ⊙
35	08017	1	O-Ring, 7/8 x 1 1/16 x 3/32 ⊙
36	09396	1	Back-Up Ring ⊙
37	07987	1	Back-Up Washer
38	00166	1	Retaining Ring
39	08019	2	Thrust Race
40	08020	1	Thrust Bearing
41	02685	4	Capscrew, 5/16-18 x 7/8 Hex Soc Head
	22729	1	Impact Mechanism, Std
	20490	1	Impact Mechanism, w/Extended Anvil and Assist Handle
42	08067	1	Hammer
43	20257	1	Hammer Frame
44	08069	2	Hammer Pin
45	22728	1	Anvil - 3/4 Square Drive - Standard
	20263	1	Anvil - 3/4 Square Drive - 12 in Extended
46	20256	1	Hammer Case Assy
	20255	1	Hammer Case Assy w/Assist Handle
47	20258	1	Hammer Case Bushing
48	00149	1	O-Ring, 3 1/4 x 3/38 x 1/16 042 R16 ⊙
49	20262	1	Retaining Ring
50	21408	1	Thrust Bearing Race
51	20260	1	Thrust Bearing
52	20259	1	Retainer
53	00936	2	Adapter, 1/2 SAE to 3/8 NPT Male
54	06971	2	Locknut, 10-24
55	17275	1	Sticker, GPM
56	03693	1	Sticker, Closed Center
	06345	2	Plastic Plug (not illustrated)

NOTE: Use Part Number and Part Name when ordering.

⊙ Denotes Parts in Seal Kit

Ⓐ Supplied with Item (53)



Stanley Hydraulic Tools

Division of the Stanley Works
3810 S.E. Naef Road
Milwaukie, Oregon 97267-5698
Phone: 503/659-5660
Fax: 503/652-1780