

EA08A

Hydraulic Earth Auger

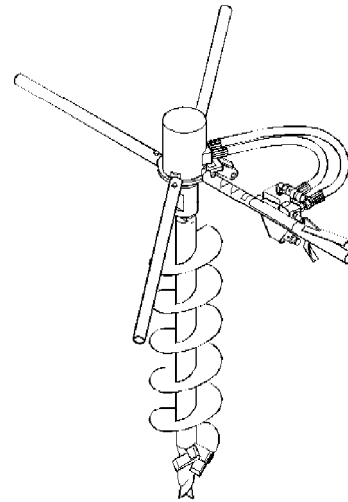

Safety, Operation and Routine Maintenance User's Manual

 DANGER
SERIOUS INJURY OR DEATH COULD RESULT FROM THE IMPROPER REPAIR OR SERVICE OF THIS TOOL.
REPAIRS AND / OR SERVICE TO THIS TOOL MUST ONLY BE DONE BY AN AUTHORIZED AND CERTIFIED DEALER.



Copyright © 2001 The Stanley Works
OPS USA & CE VERSION
43668 05/2002 Ver 2

Stanley Hydraulic Tools
3810 SE Naef Road
Milwaukie, OR 97267-5698 USA
Phone: (503) 659-5660
Fax: (503) 652-1780

**CERTIFICATE OF CONFORMITY
 ÜBEREINSTIMMUNGS-ZERTIFIKAT
 CERTIFICAT DE CONFORMITE CEE
 D'UN MARTEAU-PIQUEUR OU D'UN BRISE-BETON EXAMINE
 CERTIFICADO DE CONFORMIDAD
 CERTIFICATO DI CONFORMITA**



I, the undersigned:
 Ich, der Unterzeichnende:
 Je soussigné:
 El abajo firmante:
 Io sottoscritto:

Winterling, David

Surname and First names/Familiennamen und Vornamen/Nom et prénoms/Nombre y apellido/Cognome e nome

hereby certify that the construction plant or equipment specified hereunder:
 bestätigt hiermit, daß die Konstruktion und Ausrüstung wie folgt spezifiziert ist:
 atteste que le brise-béton:
 por el presente certifico que la fabrica o el equipo especificado a continuacion:
 certifico che l'impianto o l'attrezzatura sotto specificata:

1. Category: Earth Auger (Hydraulic)
 Kategorie:
 Catégorie:
 Categoria:
 Categoría:
2. Make/Ausführung/Marque/Marca/Fabbricazione Stanley
3. Type/Typ/Type/Tipo/Tipo: EA08101A, EA08102A
4. Type serial number of equipment:
 Typ und Serien - Nr. der Ausrüstung:
 Numéro dans la série du type de matériel:
 Numero de serie tipo del equipo:
 Matricola dell'attrezzatura:
5. Year of manufacture/Baujahr/année de fabrication/Año de fabricacion/Anno di fabbricazione 2001

All

Has been manufactured in conformity with - EEC Type examination as shown.
 wurde hergestellt in Übereinstimmung mit - EEC Typ-Prüfung nach.
 est fabriqué conformément - au(x) type(s) examiné(s) comme indiqué dans le tableau di-après.
 ha sido fabricado de acuerdo con - tipo examen EEC como dice.
 è stata costruita in conformità con - le norme CEE come illustrato.

Examen CEE de type				
Directive Richtlinie Directives particulières Directriz Direttiva	No. Nr Numéro No n.	Date Datum Date Fecha Data	Approved body Prüfung durch Organisme agréé Aprobado Collaudato	Date of expiry Ablauf datum Date d'expiration Fecha de caducidad Data di scadenza
EN	292-1, 292-2	1991	Self	N/A
EN	28662-1	1988	Self	N/A
EN	3744	1994	Self	N/A

6. Special Provisions: None
 Spezielle Bestimmungen:
 Dispositions particulières:
 Provisiones especiales:
 Misure special:
7. Measurements: Sound Power Level (dBA) 96
 Weighted Vibration Level (m/s²) 6.0

Done at/Ort/Fait à/Dado en/Fatto a Stanley Hydraulic Tools, Milwaukie, Oregon USA Date/Datum/le/Fecha/Data 2001

Signature/Unterschrift/Signature/Firma/Firma

Position/Position/Fonction/Puesto/Posizione Engineering Manager

SAFETY FIRST

It is the responsibility of the operator and service technician to read rules and instructions for safe and proper operation and maintenance.

A cautious worker
using common sense
is the greatest safety device

COPYRIGHT© 2001 The Stanley Works. All rights reserved.

Under copyright law, this document may not be copied in whole or in part without the prior written consent of The Stanley Works. This exception does not permit copies to be made for others, whether or not sold. Under the law, copying includes translating into another language, format, or medium. This copyright notice must appear on any permitted copies.

Accessories	11
Certificate of Conformity (following cover page).....	0
Contents (this page)	1
Hydraulic Hose Requirements	6
Hydraulic Requirements	7
Model Descriptions	8
Operation	8 - 9
Safety Precautions	2 - 3
Parts Illustration	13
Parts List.....	12
Specifications	11
Tool Stickers and Tags	4 - 5
Troubleshooting	10
Warranty	14

SERVICING THE EA08 EARTH AUGER: This manual contains safety, operation, and routine maintenance instructions. Stanley Hydraulic Tools recommends that servicing of hydraulic tools, other than routine maintenance, must be performed by an authorized and certified dealer. Please read the following warning.

 **DANGER**

SERIOUS INJURY OR DEATH COULD RESULT FROM THE IMPROPER REPAIR OR SERVICE OF THIS TOOL.

REPAIRS AND / OR SERVICE TO THIS TOOL MUST ONLY BE DONE BY AN AUTHORIZED AND CERTIFIED DEALER.

Tool operators and maintenance personnel must always comply with the safety precautions given in this manual and on the stickers and tags attached to the tool and hose.

These safety precautions are given for your safety. Review them carefully before operating the tool and before performing general maintenance or repairs.

Supervising personnel should develop additional precautions relating to the specific work area and local safety regulations. If so, place the added precautions in the space provided on page 3.

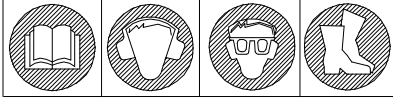

GENERAL SAFETY PRECAUTIONS

The EA08 Hydraulic Earth Auger will provide safe and dependable service if operated in accordance with the instructions given in this manual. Read and understand this manual and any stickers and tags attached to the tool and hoses before operation. Failure to do so could result in personal injury or equipment damage.

- Operator must start in a work area without bystanders. The operator must be familiar with all prohibited work areas such as excessive slopes and dangerous terrain conditions.
- Establish a training program for all operators to ensure safe operation.
- Do not operate the tool unless thoroughly trained or under the supervision of an instructor.
- Always wear safety equipment such as goggles, head protection, and safety shoes at all times when operating the tool.
- Do not inspect or clean the tool while the hydraulic power source is connected. Accidental engagement of the tool can cause serious injury.
- Do not operate the earth auger without first installing the torque tube.
- Do not install or remove an auger while the hydraulic power source is connected. Accidental engagement of the tool can cause serious injury.
- Never operate the earth auger if you cannot be sure that underground utilities are not present. Underground electrical utilities present an electrocution hazard. Underground gas utilities present an explosion hazard. Other underground utilities may present other hazards.
- Do not wear loose fitting clothing when operating the earth auger. Loose fitting clothing can get entangled with the earth auger and cause serious injury.
- Always operate the earth auger at full throttle. Operating the earth auger with the trigger slightly depressed raises the hydraulic pressure which increases torque output. This type of operation can result in unexpected "kick-back".
- Do not remove the earth auger from a hole until it has completely stopped turning.
- Supply hoses must have a minimum working pressure rating of 2500 psi/175 bar.
- Be sure all hose connections are tight.

- The hydraulic circuit control valve must be in the "OFF" position when coupling or uncoupling the tool. Wipe all couplers clean before connecting. Failure to do so may result in damage to the quick couplers and cause overheating of the hydraulic system. Use only lint-free cloths.
- Do not operate the tool at oil temperatures above 140°F/60°C. Operation at higher oil temperatures can cause operator discomfort and may damage the tool.
- Do not operate a damaged, improperly adjusted, or incompletely assembled tool.
- To avoid personal injury or equipment damage, all tool repair, maintenance and service must only be performed by authorized and properly trained personnel.
- Do not exceed the rated limits of the tool or use the tool for applications beyond its design capacity.
- Always keep critical tool markings, such as labels and warning stickers legible.
- Always replace parts with replacement parts recommended by Stanley Hydraulic Tools.
- Check fastener tightness often and before each use daily.

SAFETY SYMBOLS

Safety symbols are used to emphasize all operator, maintenance and repair actions which, if not strictly followed, could result in a life-threatening situation, bodily injury or damage to equipment.



This safety symbol may appear on the tool. It is used to alert the operator of an action that could place him/her or others in a life threatening situation.



This safety symbol appears in these instructions to identify an action that could cause bodily injury to the operator or other personnel.



This safety symbol appears in these instructions to identify an action or condition that could result in damage to the tool or other equipment.

Always observe safety symbols. They are included for your safety and for the protection of the tool.

LOCAL SAFETY REGULATIONS

Enter any local safety regulations here. Keep these instructions in an area accessible to the operator and maintenance personnel.

TOOL STICKERS & TAGS

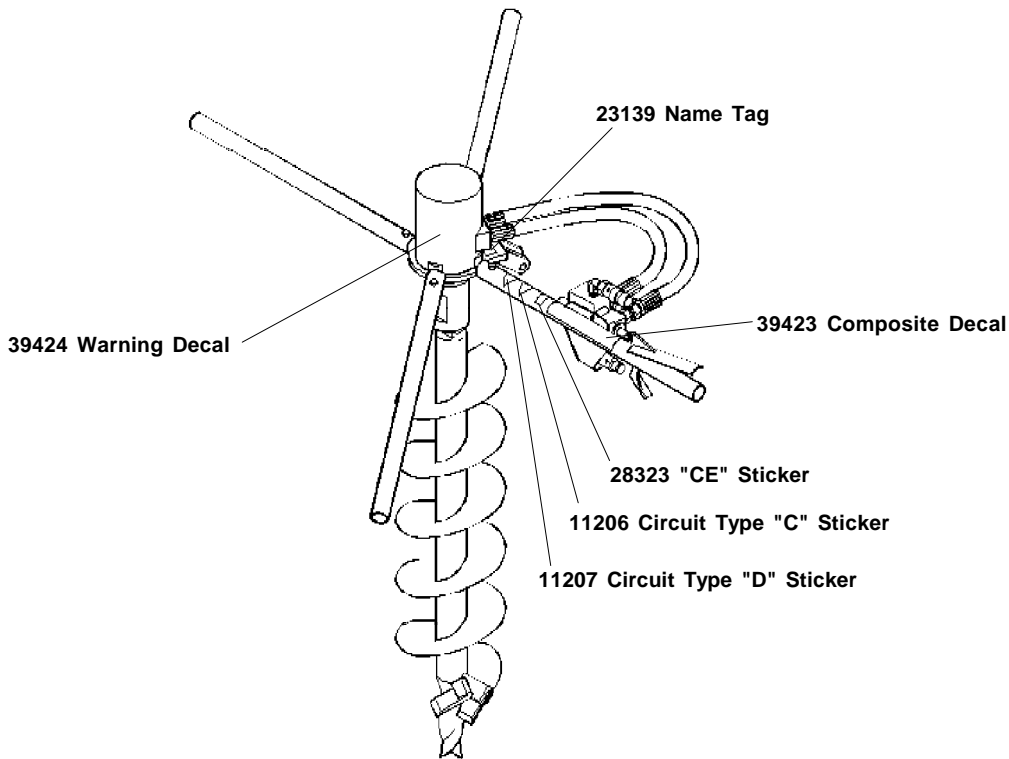

The safety tag (p/n 15875) at right is attached to the tool when shipped from the factory. Read and understand the safety instructions listed on this tag before removal. We suggest you retain this tag and attach it to the tool when not in use.

DANGER

1. FAILURE TO USE HYDRAULIC HOSE LABELED AND CERTIFIED AS NON-CONDUCTIVE WHEN USING HYDRAULIC TOOLS ON OR NEAR ELECTRICAL LINES MAY RESULT IN DEATH OR SERIOUS INJURY.

BEFORE USING HOSE LABELED AND CERTIFIED AS NON-CONDUCTIVE ON OR NEAR ELECTRIC LINES BE SURE THE HOSE IS MAINTAINED AS NON-CONDUCTIVE. THE HOSE SHOULD BE REGULARLY TESTED FOR ELECTRIC CURRENT LEAKAGE IN ACCORDANCE WITH YOUR SAFETY DEPARTMENT INSTRUCTIONS.
2. A HYDRAULIC LEAK OR BURST MAY CAUSE OIL INJECTION INTO THE BODY OR CAUSE OTHER SEVERE PERSONAL INJURY.
 - A. DO NOT EXCEED SPECIFIED FLOW AND PRESSURE FOR THIS TOOL. EXCESS FLOW OR PRESSURE MAY CAUSE A LEAK OR BURST.
 - B. DO NOT EXCEED RATED WORKING PRESSURE OF HYDRAULIC HOSE USED WITH THIS TOOL. EXCESS PRESSURE MAY CAUSE A LEAK OR BURST.
 - C. CHECK TOOL HOSE COUPLERS AND CONNECTORS DAILY FOR LEAKS. DO NOT FEEL FOR LEAKS WITH YOUR HANDS. CONTACT WITH A LEAK MAY RESULT IN SEVERE PERSONAL INJURY.

IMPORTANT

READ OPERATION MANUAL AND SAFETY INSTRUCTIONS FOR THIS TOOL BEFORE USING IT.

USE ONLY PARTS AND REPAIR PROCEDURES APPROVED BY STANLEY AND DESCRIBED IN THE OPERATION MANUAL.

TAG TO BE REMOVED ONLY BY TOOL OPERATOR.

SEE OTHER SIDE 15875

DANGER

- D. DO NOT LIFT OR CARRY TOOL BY THE HOSES. DO NOT ABUSE HOSE. DO NOT USE KINKED, TORN OR DAMAGED HOSE.
3. MAKE SURE HYDRAULIC HOSES ARE PROPERLY CONNECTED TO THE TOOL BEFORE PRESSURING SYSTEM. SYSTEM PRESSURE HOSE MUST ALWAYS BE CONNECTED TO TOOL "IN" PORT. SYSTEM RETURN HOSE MUST ALWAYS BE CONNECTED TO TOOL "OUT" PORT. REVERSING CONNECTIONS MAY CAUSE REVERSE TOOL OPERATION WHICH CAN RESULT IN SEVERE PERSONAL INJURY.
4. DO NOT CONNECT OPEN-CENTER TOOLS TO CLOSED-CENTER HYDRAULIC SYSTEMS. THIS MAY RESULT IN LOSS OF OTHER HYDRAULIC FUNCTIONS POWERED BY THE SAME SYSTEM AND/OR SEVERE PERSONAL INJURY.
5. BYSTANDERS MAY BE INJURED IN YOUR WORK AREA. KEEP BYSTANDERS CLEAR OF YOUR WORK AREA.
6. WEAR HEARING, EYE, FOOT, HAND AND HEAD PROTECTION.
7. TO AVOID PERSONAL INJURY OR EQUIPMENT DAMAGE, ALL TOOL REPAIR MAINTENANCE AND SERVICE MUST ONLY BE PERFORMED BY AUTHORIZED AND PROPERLY TRAINED PERSONNEL.

IMPORTANT

READ OPERATION MANUAL AND SAFETY INSTRUCTIONS FOR THIS TOOL BEFORE USING IT.

USE ONLY PARTS AND REPAIR PROCEDURES APPROVED BY STANLEY AND DESCRIBED IN THE OPERATION MANUAL.

TAG TO BE REMOVED ONLY BY TOOL OPERATOR.

SEE OTHER SIDE 15875

SAFETY TAG P/N 15875 (shown smaller than actual size)

TOOL STICKERS & TAGS CONTINUED

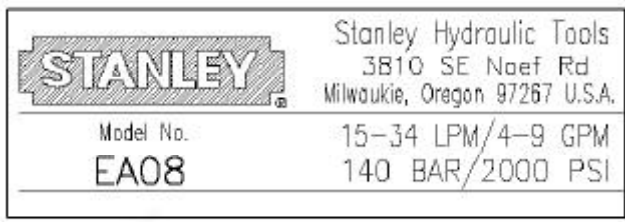

NAME TAG STICKER p/n 23139
(shown smaller than actual size)

A name tag sticker is attached to the tool. Never exceed the flow and pressure levels specified on this sticker.

The information listed on the name tag sticker must be legible at all times. Replace this sticker if it becomes worn or damaged. A re-placement is available from your local Stanley distributor.

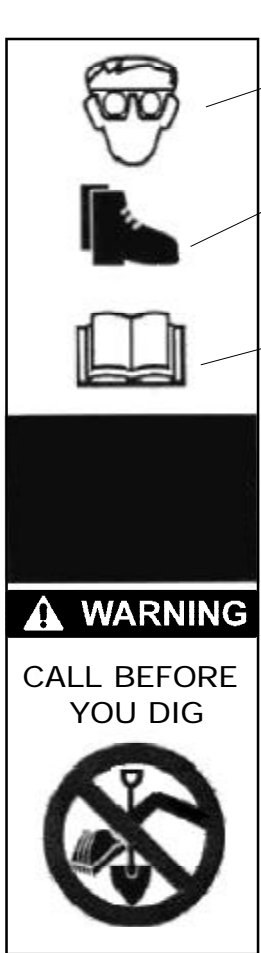

COMPOSITE STICKER p/n 39423
(shown smaller than actual size)

SIGNIFIES
"WEAR EYE PROTECTION"

SIGNIFIES
"WEAR FOOT PROTECTION"

SIGNIFIES
"READ THE MANUAL "



CE STICKER p/n 28323
(shown approx size)

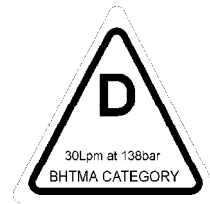

CIRCUIT "D" STICKER
p/n 11207
(shown smaller than actual size)

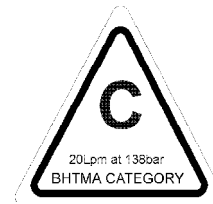

CIRCUIT "C" STICKER
p/n 11206
(shown smaller than actual size)

WARNING DECAL p/n 39424
(shown smaller than actual size)



HYDRAULIC HOSE REQUIREMENTS

HOSE TYPES

Hydraulic hose types authorized for use with Stanley Hydraulic Tools are as follows:

- ① Certified non-conductive
- ② Wire-braided (conductive)
- ③ Fabric-braided (not certified or labeled non-conductive)

Hose ① listed above is the only hose authorized for use near electrical conductors.

Hoses ② and ③ listed above are **conductive** and **must never** be used near electrical conductors.

HOSE SAFETY TAGS

To help ensure your safety, the following DANGER tags are attached to all hose purchased from Stanley Hydraulic Tools. **DO NOT REMOVE THESE TAGS.**

If the information on a tag is illegible because of wear or damage, replace the tag immediately. A new tag may be obtained at no charge from your Stanley Distributor.

The tag shown below is attached to "certified non-conductive" hose.

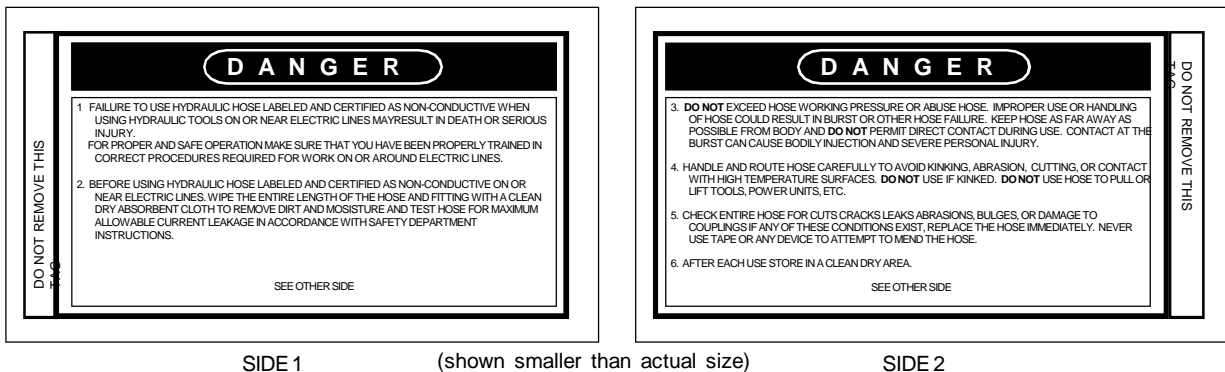

The tag shown below is attached to "conductive" hose.

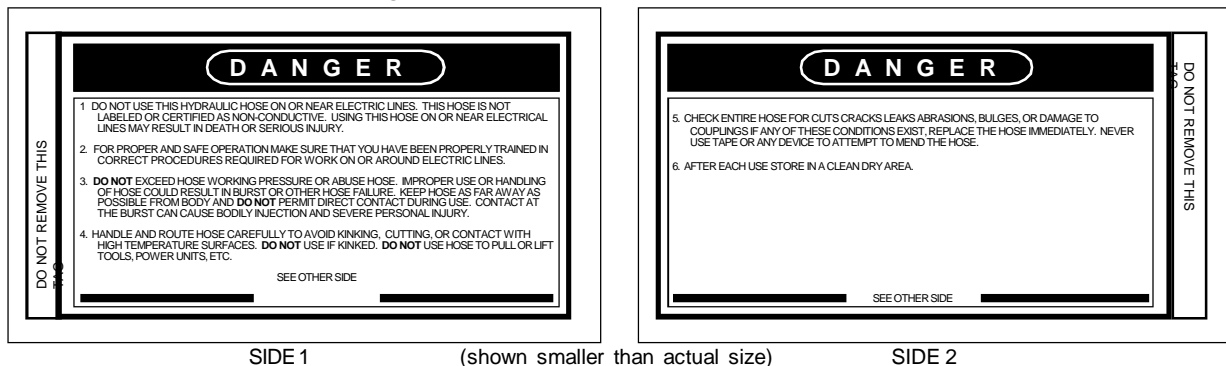

HOSE PRESSURE RATING

The rated working pressure of the hydraulic hose **must be equal to or higher than** the relief valve setting on the hydraulic system.

HYDRAULIC SYSTEM REQUIREMENTS

- The hydraulic system should provide a flow of 4-9 gpm/15-34 lpm at an operating pressure of 2000 psi/140 bar. Recommended relief valve setting is 2100-2250 psi/145-155 bar.
- The system should have no more than 250 psi/17 bar backpressure measured at the tool end of the operating hoses. The system conditions for measurement are at maximum fluid viscosity of 400 ssu/82 centistokes (minimum operating temperatures).
- The hydraulic system should have enough heat rejection capacity to limit the maximum oil temperature to 140°F/60°C at the maximum expected ambient temperature.
- The hydraulic system should have a minimum of 25 micron filtration. Stanley recommends using filter elements sized for a flow of at least 30 gpm/114 lpm for cold temperature startup and maximum dirt holding capacity.
- The hydraulic fluid used should have a viscosity between 100 and 400 ssu/20 and 82 centistokes at the maximum and minimum expected operating temperatures. Petroleum base hydraulic fluids with antiwear properties and a viscosity index over 140 ssu/28 centistokes will meet the recommended requirements over a wide range of operating temperatures.
- The recommended hose size is .500 inch/12 mm I.D. up to 50 ft/15 m long and .625 inch/16 mm I.D. minimum up to 100 ft/30 m long.
- Quick disconnect couplings must conform to NFPA T3.20,15/EHTMA specifications.

OPERATING INSTRUCTIONS

PREOPERATION PROCEDURES

Preparation For Initial Use

The **handles & torque tube**, which are shipped unattached, must be connected to the tool prior to operation. An optional auger bit must also be connected to the tool for proper operation. Inspect the tool to assure the tool was not damaged in shipping and does not contain packing debris.

Check Hydraulic Power Source

1. Using a calibrated flowmeter and pressure gauge, check that the hydraulic power source develops a flow of 4-9 gpm/15-34 lpm at 2000 psi/140 bar.
2. Make certain the hydraulic power source is equipped with a relief valve set to open at 2100-2250 psi/145-155 bar minimum.
3. Check that the hydraulic circuit matches the tool for open-center (OC) operation.

Install Handles

Refer to the assembly instructions provided with the tool.

1. Install the handles (1) and fasteners (2). Tighten each fastener to 40 ft. lbs./54 Nm.

Check Tool

1. Make sure all tool accessories are correctly installed. Failure to install tool accessories properly can result in damage to the tool or personal injury.
2. There should be no signs of leaks.
3. The tool should be clean, with all fittings and fasteners tight.

Check Trigger Mechanism

1. Check that the trigger operates smoothly and is free to travel between the "ON" - "OFF" - "ON" positions.

Install Auger Bit

The EA08 Earth Auger accepts standard 1-1/4 inch

square shank augers for the model EA08101A and standard 1-3/8 inch female hex socket for the model EA08102A.

TO INSTALL AN AUGER TO THE MODEL EA08101A

Align the button on the auger chuck with the hole in the coupler (15). Slide the auger chuck into the coupler until the button seats in the hole. See figure 1.

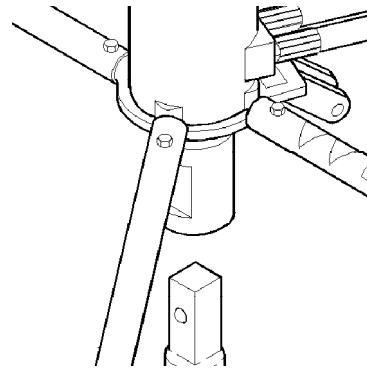

Figure 1. Installing Auger to model EA08101A

TO INSTALL AN AUGER TO THE MODEL EA08102A

Align the hole on the auger chuck with the hole in the coupler (15). Slide the auger chuck into the coupler. Secure it using a 3/8 inch long bolt and a nut. See figure 2.

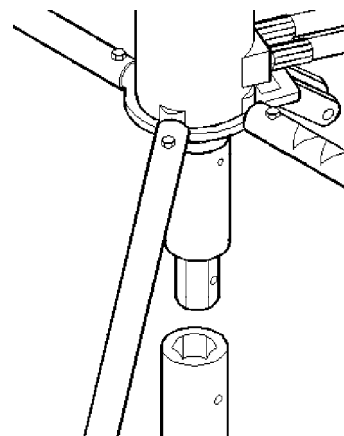

Figure 2. Installing Auger to model EA08102A

Install Torque Tube

1. The torque tube is attached to the base as shown in figure 3. Be sure to use the cotterless clevis pin provided with the unit. Make sure the pin is pushed through both holes in the base.
2. The opposite end of the tube can be connected to a solid object, such as the Stanley hydraulic power unit, a trailer hitch ball, ground stake, etc.
3. Position yourself so that you are able to operate the ON/OFF trigger with your right hand. Grasp each handle firmly. Your helper positions himself/herself directly opposite and facing you and grasping each handle firmly.
4. Lift the EA08, with auger attached, and position the auger so it is perpendicular to where you intend to dig. The auger should be just above (not touching) the ground.

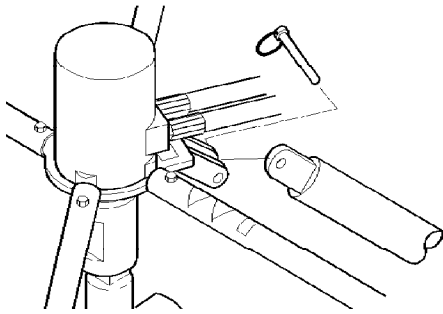

Figure 3. Installing Torque Tube

Connect Hoses

1. Wipe all hose couplers with a clean lint-free cloth before making connections.
2. Connect the hoses from the hydraulic power source to the hose couplers on the tool. It is a good practice to connect the return hose first and disconnect it last to minimize or avoid trapped pressure within the tool.
3. Observe flow indicators stamped on hose couplers to be sure that oil will flow in the proper direction. The female coupler is the inlet coupler.

NOTE: The pressure increase in uncoupled hoses left in the sun may result in making them difficult to connect. When possible, connect the free ends of operating hoses together.

5. With your feet, and your helper's feet, spread and firmly planted, squeeze the ON/OFF trigger fully to start the auger turning.
6. Lower the EA08 until the auger starts digging. With soft soil the auger will penetrate into the ground with little effort and may require you to apply a slight lift to the EA08. With hard soil the auger cannot penetrate the ground easily and may require you to apply some down pressure to the EA08. Try not to apply enough down pressure to stall the auger. Augering in different soils requires different techniques and practice to become proficient.
7. After reaching the desired depth, lift the auger straight out of the hole. Always release the ON/OFF trigger before the tip of the auger reaches the top of the hole.

COLD WEATHER OPERATION

If the tool is to be used during cold weather, preheat the hydraulic fluid at low engine speed. When using the normally recommended fluids, fluid temperature should be at or above 50° F/10° C (400 ssu/82 centistokes) before use.

OPERATING PROCEDURES

1. Observe all safety precautions.
2. Make sure the torque tube is attached to the base of the EA08 and anchored to a solid object.

NOTE: It is recommended to always use the torque tube.

TROUBLE SHOOTING

If symptoms of poor performance develop, the following chart can be used as a guide to correct the problem.

When diagnosing faults in operation of the tool, always check that the hydraulic power source is supplying the correct hydraulic flow and pressure to the breaker as

listed in the table. Use a flowmeter known to be accurate. Check the flow with the hydraulic oil temperature at least 80°F/27°C.

Earth Auger does not run.	Power unit not functioning.	Check power unit for proper flow and pressure (4-9 gpm / 15-34 lpm, 2000 psi / 140 bar).
	Couplers or hoses blocked.	Remove restriction.
	Pressure and return line hoses reversed at ports.	Be sure hoses are connected to their proper ports.
Poor Earth Auger performance.	Power unit not functioning.	Check power unit for proper flow and pressure (7-9 gpm / 26-34 lpm, 2000 psi / 140 bar).
	Couplers or hose blocked.	Remove restriction,
	Fluid too hot (above 140 ° F / 60° C).	Provide cooler to maintain proper fluid temperature.
Earth Auger operates slow.	Low oil flow from power unit.	Check power source for proper flow.
	High backpressure.	Check hydraulic system for excessive backpressure and correct as required.

SPECIFICATIONS

Pressure Range2000 psi/140 bar
 Maximum Back Pressure250 psi/17 bar
 Couplers HTMA/EHTMA Flush Face Type Male & Female
 Connect Size and Type 1/2 in. Male Pipe Adapter



Weight

.....47 lbs / 21 kg

Overall Length41 in. / 104 cm
 Overall Width30 in. / 76 cm
 Overall Height (Less Auger)12 in. /30.5 cm
 Maximum Fluid Temperature 140° F/60° C

HTMA Class I4-6 gpm @ 2000 psi



EHTMA Category

.....20 lpm @ 138 bar

HTMA Class II7-9 gpm @ 2000 psi



EHTMA Category

.....30 lpm @ 138 bar

Sound Pressure Level Less Than 85 dBA
 Vibration Level 6.0 (m/s²)

ACCESSORIES

DESCRIPTION

PART NUMBER

Auger, 8 in. dia. x 42 in. long (1-1/4 inch Square Drive)
 Auger Extension, 8 in. dia x 32 in. long (1-1/4 inch Square Drive)
 Coupler, 1-1/4 inch female hex

39409
 39410
 43660

EA08 PARTS LIST

Item No	Part No	Qty	Description
1	37919	3	Handle
2	39415	4	Capscrew
3	39276	1	Motor (Parker TB-0165-F-S-10-0-AAAB)
4	37917	1	Base Assy
5	06151	4	Capscrew
6	-----	2	Clevis Pin (furnished with item 28)
7	00720	1	Set Screw
8	-----	1	Key (furnished with item 3)
9	11207	1	Circuit Type D Sticker
10	11206	1	Circuit Type C Sticker
11	28323	1	CE Sticker
12	00719	3	Nut, Nylock
13	39423	1	Composite Decal
14	39277	1	Valve Mount Handle
15	39408	1	Coupler, 1-1/4 sq., (model EA08101A only)
	43662	1	Coupler, 1-3/8 hex, (model EA08102A only)
16	43536	1	Support Washer (model EA08101A only)
17	371049	1	Lockwasher (model EA08101A only)
18	01521	1	Capscrew (model EA08101A only)
	00718	1	Capscrew (model EA08102A only)
19	39404	2	Elbow
20	24061	1	Flush Face Coupler, Male
21	39279	1	Trigger
22	-----	2	Cotter Pin (Incl'd with item 28)
23	08523	3	Capscrew
24	39283	1	Hose, Long
25	39282	1	Hose, Short
26	10351	2	Adapter
27	24060	1	Flush Face Coupler, Female
28	39278	1	Valve, Brand A0755-T-4-J-S
29	37923	1	Torque Tube Assy
30	23139	1	Name Tag
31	21181	1	Pin
32	39424	1	Warning Decal

SEAL KIT P/N

39411

NOTE: Use Part Number and Part Name when ordering.

NOTES

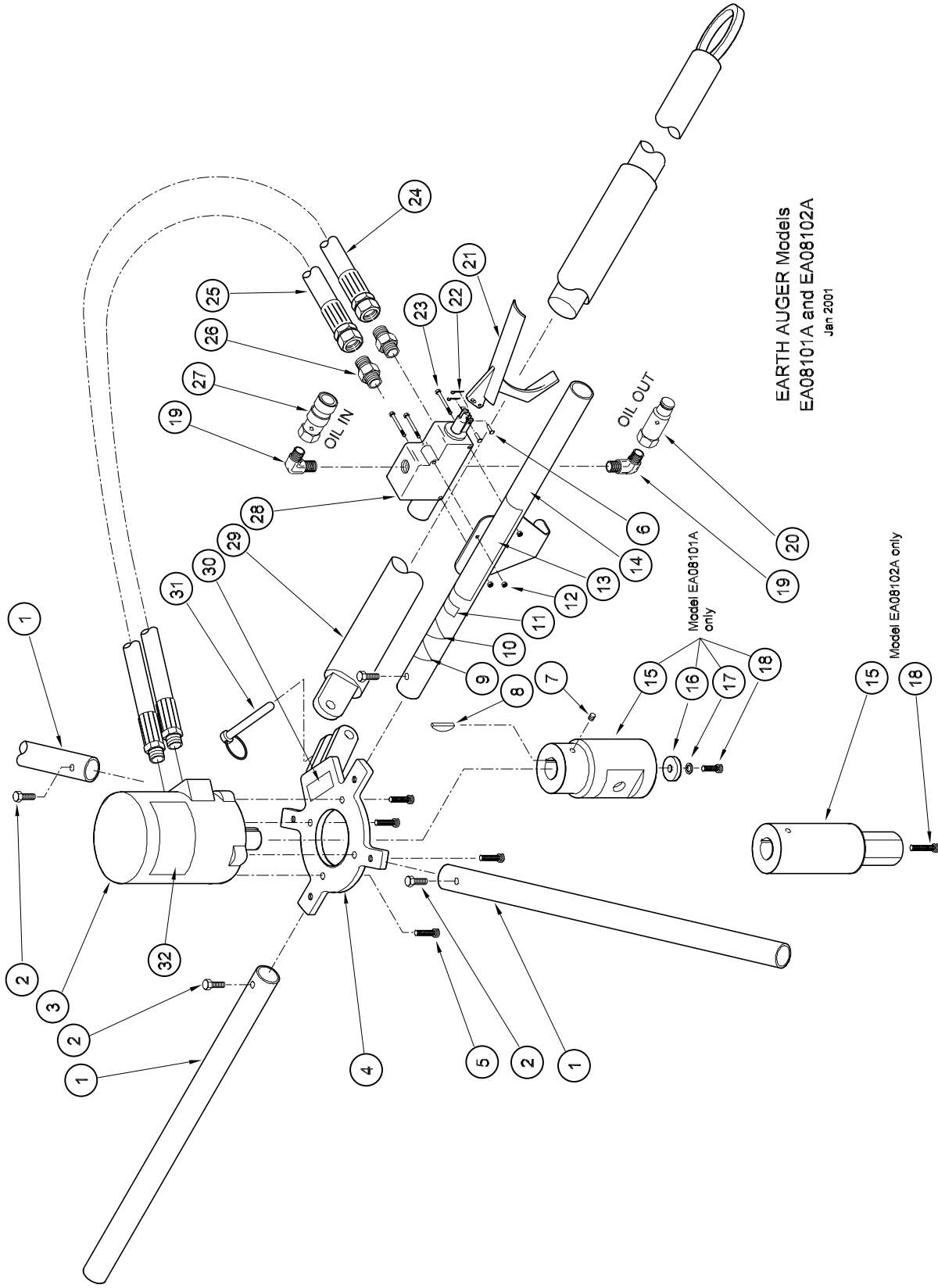

EARTH AUGER Models
EA08101A and EA08102A
Jan 2001

WARRANTY

Stanley Hydraulic Tools (hereinafter called "Stanley"), subject to the exceptions contained below, warrants new hydraulic tools for a period of one year from the date of sale to the first retail purchaser, or for a period of 2 years from the shipping date from Stanley, whichever period expires first, to be free of defects in material and/or workmanship at the time of delivery, and will, at its option, repair or replace any tool or part of a tool, or new part, which is found upon examination by a Stanley authorized service outlet or by Stanley's factory in Milwaukee, Oregon to be DEFECTIVE IN MATERIAL AND/OR WORKMANSHIP.

EXCEPTIONS FROM WARRANTY

NEW PARTS: New parts which are obtained individually are warranted, subject to the exceptions herein, to be free of defects in material and/or workmanship at the time of delivery and for a period of 6 months after the date of first usage. Seals and diaphragms are warranted to be free of defects in material and/or workmanship at the time of delivery and for a period of 6 months after the date of first usage or 2 years after the date of delivery, whichever period expires first. Warranty for new parts is limited to replacement of defective parts only. Labor is not covered.

FREIGHT COSTS: Freight costs to return parts to Stanley, if requested by Stanley for the purpose of evaluating a warranty claim for warranty credit, are covered under this policy if the claimed part or parts are approved for warranty credit. Freight costs for any part or parts which are not approved for warranty credit will be the responsibility of the individual.

SEALS & DIAPHRAGMS: Seals and diaphragms installed in new tools are warranted to be free of defects in material and/or workmanship for a period of 6 months after the date of first usage, or for a period of 2 years from the shipping date from Stanley, whichever period expires first.

CUTTING ACCESSORIES: Cutting accessories such as breaker tool bits are warranted to be free of defects in material and or workmanship at the time of delivery only.

ITEMS PRODUCED BY OTHER MANUFACTURERS: Components which are not manufactured by Stanley and are warranted by their respective manufacturers.

- a. Costs incurred to remove a Stanley manufactured component in order to service an item manufactured by other manufacturers.

ALTERATIONS & MODIFICATIONS: Alterations or modifications to any tool or part. All obligations under this warranty shall be terminated if the new tool or part is altered or modified in any way.

NORMAL WEAR: any failure or performance deficiency attributable to normal wear and tear such as tool bushings, retaining pins, wear plates, bumpers, retaining rings and plugs, rubber bushings, recoil springs, etc.

INCIDENTAL/CONSEQUENTIAL DAMAGES: To the fullest extent permitted by applicable law, in no event will STANLEY be liable for any incidental, consequential or special damages and/or expenses.

FREIGHT DAMAGE: Damage caused by improper storage or freight handling.

LOSS TIME: Loss of operating time to the user while the tool(s) is out of service.

IMPROPER OPERATION: Any failure or performance deficiency attributable to a failure to follow the guidelines and/or procedures as outlined in the tool's operation and maintenance manual.

MAINTENANCE: Any failure or performance deficiency attributable to not maintaining the tool(s) in good operating condition as outlined in the Operation and Maintenance Manual.

HYDRAULIC PRESSURE & FLOW, HEAT, TYPE OF FLUID: Any failure or performance deficiency attributable to excess hydraulic pressure, excess hydraulic back-pressure, excess hydraulic flow, excessive heat, or incorrect hydraulic fluid.

REPAIRS OR ALTERATIONS: Any failure or performance deficiency attributable to repairs by anyone which in Stanley's sole judgement caused or contributed to the failure or deficiency.

MIS-APPLICATION: Any failure or performance deficiency attributable to mis-application. "Mis-application" is defined as usage of products for which they were not originally intended or usage of products in such a manner which exposes them to abuse or accident, without first obtaining the written consent of Stanley. PERMISSION TO APPLY ANY PRODUCT FOR WHICH IT WAS NOT ORIGINALLY INTENDED CAN ONLY BE OBTAINED FROM STANLEY ENGINEERING.

WARRANTY REGISTRATION: STANLEY ASSUMES NO LIABILITY FOR WARRANTY CLAIMS SUBMITTED FOR WHICH NO TOOL REGISTRATION IS ON RECORD. In the event a warranty claim is submitted and no tool registration is on record, no warranty credit will be issued without first receiving documentation which proves the sale of the tool or the tools' first date of usage. The term "DOCUMENTATION" as used in this paragraph is defined as a bill of sale, or letter of intent from the first retail customer. A WARRANTY REGISTRATION FORM THAT IS NOT ALSO ON RECORD WITH STANLEY WILL NOT BE ACCEPTED AS "DOCUMENTATION".

NO ADDITIONAL WARRANTIES OR REPRESENTATIONS

This limited warranty and the obligation of Stanley thereunder is in lieu of all other warranties, expressed or implied including merchantability or fitness for a particular purpose except for that provided herein. There is no other warranty. This warranty gives the purchaser specific legal rights and other rights may be available which might vary depending upon applicable law.



Stanley Hydraulic Tools • 3810 S.E. Naef Road • Milwaukie, Oregon 97267-5698
Phone: 503/659-5660 • Fax: 503/652-1780