



# CH15

# HYDRAULIC CHIPPING HAMMER



**⚠ WARNING**

SERIOUS INJURY OR DEATH  
COULD RESULT FROM IM-  
PROPER REPAIR OR SERVICE  
OF THIS TOOL.

REPAIRS AND/OR SERVICE  
TO THIS TOOL MUST ONLY  
BE DONE BY AN AUTHORIZED  
AND CERTIFIED DEALER.

**⚠ WARNING**

To avoid serious injury or death

## SAFETY, OPERATION AND MAINTENANCE SERVICE MANUAL



---

# TABLE OF CONTENTS

---

Safety Symbols and Precautions .....	4, 5
Tool Stickers and Tags .....	6
Hydraulic Hose Requirements .....	7
HTMA Requirements .....	8
Operation .....	9
Equipment Protection and Care .....	11
Troubleshooting .....	12
Specifications .....	13
Accessories .....	13
Service .....	14
Parts Illustration .....	18
Parts List .....	19
Warranty .....	20

**SERVICING THE STANLEY CHIPPING HAMMER:** This manual contains safety, operation, service and routine maintenance instructions. Stanley Hydraulic Tools recommends that servicing of hydraulic tools, other than routine maintenance, must be performed by an authorized and certified dealer. Please read the following warning.

<b>⚠ WARNING</b>
------------------

<b>SERIOUS INJURY OR DEATH COULD RESULT FROM THE IMPROPER REPAIR OR SERVICE OF THIS TOOL.</b>
---

<b>REPAIRS AND / OR SERVICE TO THIS TOOL MUST ONLY BE DONE BY AN AUTHORIZED AND CERTIFIED DEALER.</b>
---

For the nearest authorized and certified dealer, call Stanley Hydraulic Tools at one of the numbers listed on the back of this manual and ask for a Customer Service Representative.

---

# SAFETY SYMBOLS

---

Safety symbols and signal words, as shown below, are used to emphasize all operator, maintenance and repair actions which, if not strictly followed, could result in a life-threatening situation, bodily injury or damage to equipment.



This is the safety alert symbol. It is used to alert you to potential personal injury hazards. Obey all safety messages that follow this symbol to avoid possible injury or death.



This safety alert and signal word indicate an imminently hazardous situation which, if not avoided, will result in death or serious injury.



This safety alert and signal word indicate a potentially hazardous situation which, if not avoided, could result in death or serious injury.



This safety alert and signal word indicate a potentially hazardous situation which, if not avoided, may result in minor or moderate injury.



This signal word indicates a potentially hazardous situation which, if not avoided, may result in property damage.



This signal word indicates a situation which, if not avoided, will result in damage to the equipment.



This signal word indicates a situation which, if not avoided, may result in damage to the equipment.

Always observe safety symbols. They are included for your safety and for the protection of the tool.

## LOCAL SAFETY REGULATIONS

Enter any local safety regulations here. Keep these instructions in an area accessible to the operator and maintenance personnel.

---

---

---

---

---

---

---

---

---

---

---

# SAFETY PRECAUTIONS

---

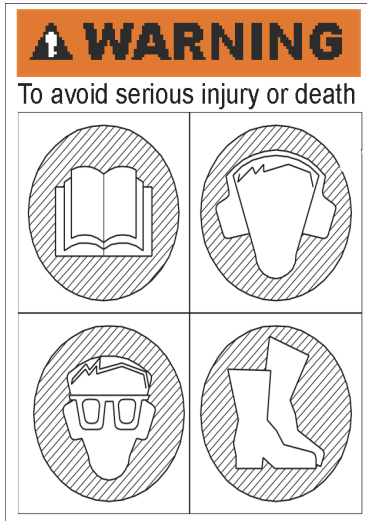

Tool operators and maintenance personnel must always comply with the safety precautions given in this manual and on the stickers and tags attached to the tool and hose.

These safety precautions are given for your safety. Review them carefully before operating the tool and before performing general maintenance or repairs.

Supervising personnel should develop additional precautions relating to the specific work area and local safety regulations. If so, place the added precautions in the space provided on page 4.

The CH15 Hydraulic Chipping Hammer will provide safe and dependable service if operated in accordance with the instructions given in this manual. Read and understand this manual and any stickers and tags attached to the tool and hoses before operation. Failure to do so could result in personal injury or equipment damage.

- Operator must start in a work area without bystanders. The operator must be familiar with all prohibited work areas such as excessive slopes and dangerous terrain conditions.
- Establish a training program for all operators to ensure safe operation.
- Do not operate the tool unless thoroughly trained or under the supervision of an instructor.
- Always wear safety equipment such as goggles, ear, head protection, and safety shoes at all times when operating the tool.
- Do not inspect or clean the tool while the hydraulic power source is connected. Accidental engagement of the tool can cause serious injury.
- Supply hoses must have a minimum working pressure rating of 2500 psi/175 bar.
- Be sure all hose connections are tight.
- The hydraulic circuit control valve must be in the "OFF" position when coupling or uncoupling the tool. Wipe all couplers clean before connecting. Use only lint-free cloths. Failure to do so may result in damage to the quick couplers and cause overheating of the hydraulic system.
- Do not operate the tool at oil temperatures above 140°F/60°C. Operation at higher oil temperatures can cause operator discomfort and may damage the tool.
- Do not operate a damaged, improperly adjusted, or incompletely assembled tool.
- Do not weld, cut with an acetylene torch, or hardface the tool bit.
- To avoid personal injury or equipment damage, all tool repair, maintenance and service must only be performed by authorized and properly trained personnel.
- Do not exceed the rated limits of the tool or use the tool for applications beyond its design capacity.
- Always keep critical tool markings, such as labels and warning stickers legible.
- Always replace parts with replacement parts recommended by Stanley Hydraulic Tools.
- Check fastener tightness often and before each use daily.

# TOOL STICKERS & TAGS

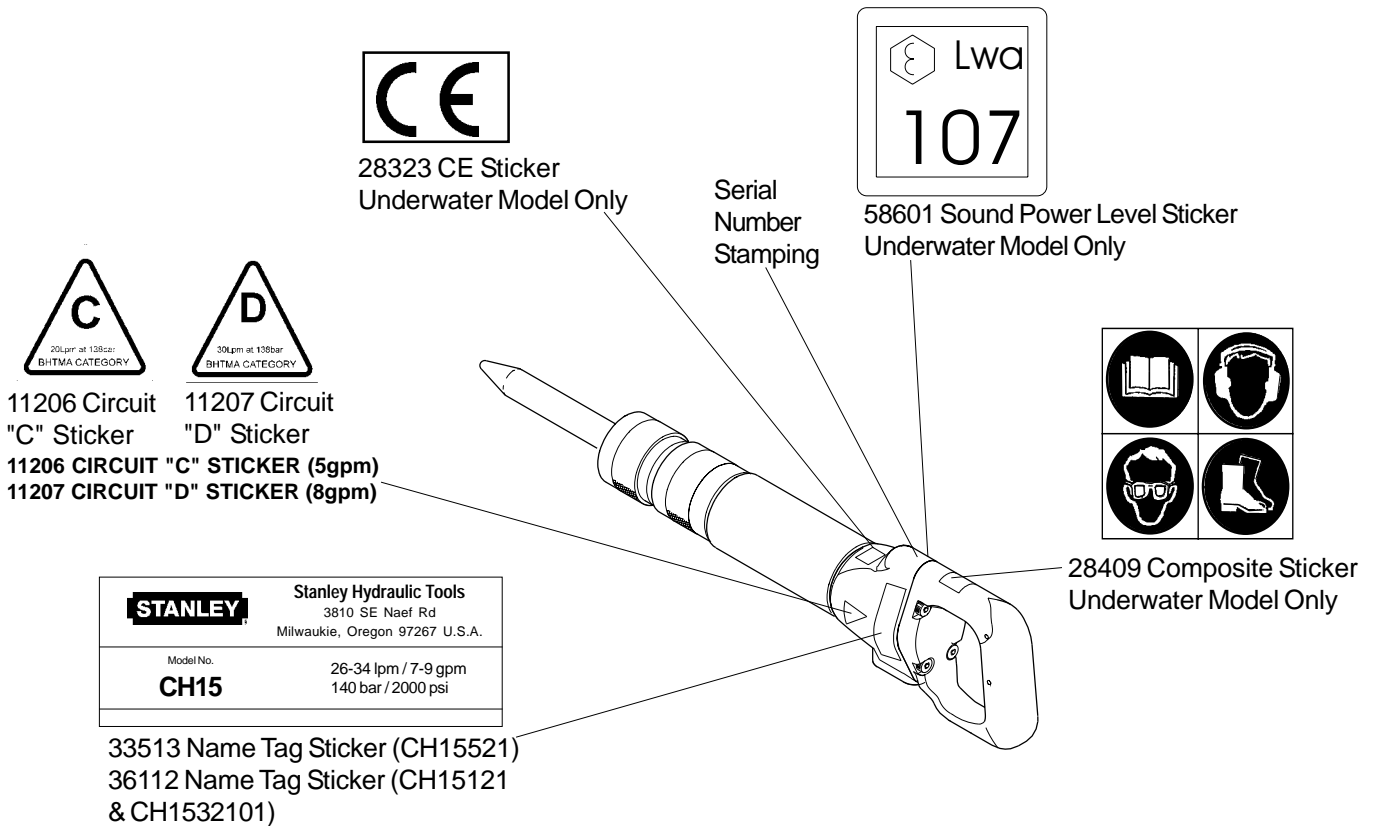

The safety tag (p/n 15875) at right is attached to the tool when shipped from the factory. Read and understand the safety instructions listed on this tag before removal. We suggest you retain this tag and attach it to the tool when not in use.

**DANGER**

1. FAILURE TO USE HYDRAULIC HOSE LABELED AND CERTIFIED AS **NON-CONDUCTIVE** WHEN USING HYDRAULIC TOOLS ON OR NEAR ELECTRICAL LINES MAY RESULT IN DEATH OR SERIOUS INJURY.

BEFORE USING HOSE LABELED AND CERTIFIED AS **NON-CONDUCTIVE** ON OR NEAR ELECTRIC LINES BE SURE THE HOSE IS **MAINTAINED AS NON-CONDUCTIVE**. THE HOSE SHOULD BE REGULARLY TESTED FOR ELECTRIC CURRENT LEAKAGE IN ACCORDANCE WITH YOUR SAFETY DEPARTMENT INSTRUCTIONS.

2. A HYDRAULIC LEAK OR BURST MAY CAUSE OIL INJECTION INTO THE BODY OR CAUSE OTHER SEVERE PERSONAL INJURY.

A. **DO NOT EXCEED SPECIFIED FLOW AND PRESSURE FOR THIS TOOL.** EXCESS FLOW OR PRESSURE MAY CAUSE A LEAK OR BURST.

B. **DO NOT EXCEED RATED WORKING PRESSURE OF HYDRAULIC HOSE USED WITH THIS TOOL.** EXCESS PRESSURE MAY CAUSE A LEAK OR BURST.

C. CHECK TOOL HOSE COUPLERS AND CONNECTORS DAILY FOR LEAKS. **DO NOT FEEL FOR LEAKS WITH YOUR HANDS.** CONTACT WITH A LEAK MAY RESULT IN SEVERE PERSONAL INJURY.

**IMPORTANT**

**READ OPERATION MANUAL AND SAFETY INSTRUCTIONS FOR THIS TOOL BEFORE USING IT.**

**USE ONLY PARTS AND REPAIR PROCEDURES APPROVED BY STANLEY AND DESCRIBED IN THE OPERATION MANUAL.**

**TAG TO BE REMOVED ONLY BY TOOL OPERATOR.**

SEE OTHER SIDE

**DANGER**

D. **DO NOT LIFT OR CARRY TOOL BY THE HOSES.** DO NOT ABUSE HOSE. DO NOT USE KINKED, TORN OR DAMAGED HOSE.

3. MAKE SURE HYDRAULIC HOSES ARE PROPERLY CONNECTED TO THE TOOL BEFORE PRESSURING SYSTEM. SYSTEM PRESSURE HOSE MUST ALWAYS BE CONNECTED TO TOOL "IN" PORT. SYSTEM RETURN HOSE MUST ALWAYS BE CONNECTED TO TOOL "OUT" PORT. REVERSING CONNECTIONS MAY CAUSE REVERSE TOOL OPERATION WHICH CAN RESULT IN SEVERE PERSONAL INJURY.

4. **DO NOT CONNECT OPEN-CENTER TOOLS TO CLOSED-CENTER HYDRAULIC SYSTEMS.** THIS MAY RESULT IN LOSS OF OTHER HYDRAULIC FUNCTIONS POWERED BY THE SAME SYSTEM AND/OR SEVERE PERSONAL INJURY.

5. **BYSTANDERS MAY BE INJURED IN YOUR WORK AREA.** KEEP BYSTANDERS CLEAR OF YOUR WORK AREA.

6. WEAR HEARING, EYE, FOOT, HAND AND HEAD PROTECTION.

7. TO AVOID PERSONAL INJURY OR EQUIPMENT DAMAGE, ALL TOOL REPAIR MAINTENANCE AND SERVICE MUST ONLY BE PERFORMED BY AUTHORIZED AND PROPERLY TRAINED PERSONNEL.

**IMPORTANT**

**READ OPERATION MANUAL AND SAFETY INSTRUCTIONS FOR THIS TOOL BEFORE USING IT.**

**USE ONLY PARTS AND REPAIR PROCEDURES APPROVED BY STANLEY AND DESCRIBED IN THE OPERATION MANUAL.**

**TAG TO BE REMOVED ONLY BY TOOL OPERATOR.**

SEE OTHER SIDE

SAFETY TAG P/N 15875 (shown smaller than actual size)

# HYDRAULIC HOSE REQUIREMENTS

## HOSE TYPES

Hydraulic hose types authorized for use with Stanley Hydraulic Tools are as follows:

- ① Certified non-conductive
- ② Wire-braided (conductive)
- ③ Fabric-braided (not certified or labeled non-conductive)

Hose ① listed above is the only hose authorized for use near electrical conductors.

Hoses ② and ③ listed above are **conductive** and **must never** be used near electrical conductors.

## HOSE SAFETY TAGS

To help ensure your safety, the following DANGER tags are attached to all hose purchased from Stanley Hydraulic Tools. **DO NOT REMOVE THESE TAGS.**

If the information on a tag is illegible because of wear or damage, replace the tag immediately. A new tag may be obtained from your Stanley Distributor.

### THE TAG SHOWN BELOW IS ATTACHED TO "CERTIFIED NON-CONDUCTIVE" HOSE

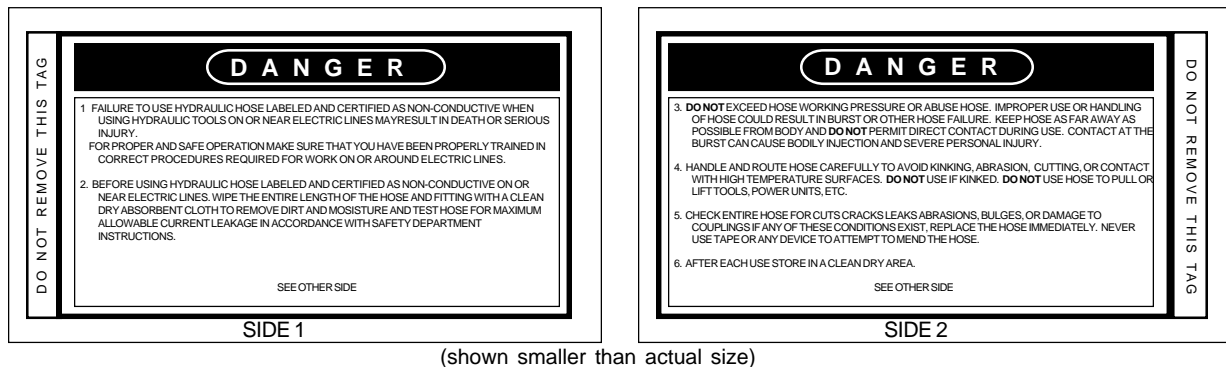

### THE TAG SHOWN BELOW IS ATTACHED TO "CONDUCTIVE" HOSE.

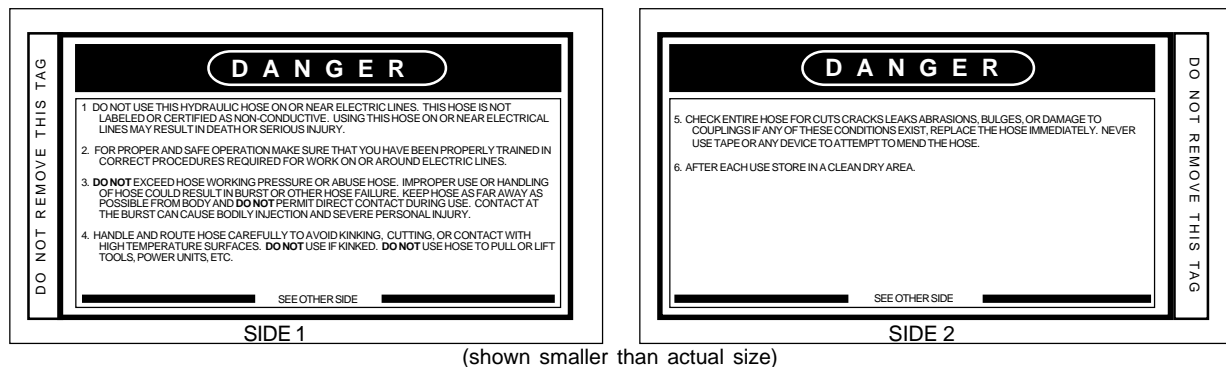

## HOSE PRESSURE RATING

The rated working pressure of the hydraulic hose **must be equal to or higher than** the relief valve setting on the hydraulic system.

# HTMA REQUIREMENTS

## Tool Category



### Hydraulic System Requirements

**Type I**

**Type II**

**Type III**

<b>Flow rate</b>	4-6 gpm (15-23 lpm)	7-9 gpm (26-34 lpm)	10.5-11.6 gpm (36-44 lpm)	11-13 gpm (42-49 lpm)
<b>Tool Operating Pressure</b> <i>(at the power supply outlet)</i>	2000 psi (138 bar)	2000 psi (138 bar)	2000 psi (138 bar)	2000 psi (138 bar)
<b>System relief valve setting</b> <i>(at the power supply outlet)</i>	2100-2250 psi (145-155 bar)	2100-2250 psi (145-155 bar)	2100-2250 psi (145-155 bar)	2100-2250 psi (145-155 bar)
<b>Maximum back pressure</b> <i>(at tool end of the return hose)</i>	200 psi (14 bar)	200 psi (14 bar)	200 psi (14 bar)	200 psi (14 bar)
<b>Measured at a max. fluid viscosity of:</b> <i>(at min. operating temperature)</i>	400 ssu* (82 centistokes)	400 ssu* (82 centistokes)	400 ssu* (82 centistokes)	400 ssu* (82 centistokes)
<b>Temperature</b>				
Sufficient heat rejection capacity to limit max. fluid temperature to: <i>(at max. expected ambient temperature)</i>	140° F (60° C)	140° F (60° C)	140° F (60° C)	140° F (60° C)
Min. cooling capacity at a temperature difference of between ambient and fluid temps	3 hp (2.24 kW) 40° F (22° C)	5 hp (3.73 kW) 40° F (22° C)	6 hp (4.47 kW) 40° F (22° C)	7 hp (5.22 kW) 40° F (22° C)
<b>NOTE:</b> Do not operate the tool at oil temperatures above 140° F (60° C). Operation at higher temperatures can cause operator discomfort at the tool.				
<b>Filter</b>				
Min. full-flow filtration	25 microns	25 microns	25 microns	25 microns
Sized for flow of at least: <i>(For cold temp. startup and max. dirt-holding capacity)</i>	18 gpm (68 lpm)	30 gpm (114 lpm)	35 gpm (132 lpm)	40 gpm (151 lpm)
<b>Hydraulic fluid</b>				
Petroleum based <i>(premium grade, anti-wear, non-conductive)</i>				
Viscosity <i>(at min. and max. operating temps)</i>	100-400 ssu* (20-82 centistokes)	100-400 ssu* (20-82 centistokes)	100-400 ssu* (20-82 centistokes)	100-400 ssu* (20-82 centistokes)
<b>NOTE:</b> When choosing hydraulic fluid, the expected oil temperature extremes that will be experienced in service determine the most suitable temperature viscosity characteristics. Hydraulic fluids with a viscosity index over 140 will meet the requirements over a wide range of operating temperatures.				

**NOTE:** These are general hydraulic system requirements. See tool Specification page for tool specific requirements.



---

# OPERATION

---

## PREOPERATION PROCEDURES

### Preparation For Initial Use

The tool, as shipped, has no special unpacking or assembly requirements prior to usage. Inspection to assure the tool was not damaged in shipping and does not contain packing debris is all that is required.

### Check Hydraulic Power Source

1. Using a calibrated flowmeter and pressure gauge, check that the hydraulic power source develops a flow of 7-9 gpm/26-34 lpm at 1500-2000 psi/105-140 bar for the CH15100, 8 gpm model.
2. Make certain the hydraulic power source is equipped with a relief valve set to open at 2100-2250 psi/145-155 bar minimum.
3. Check that the hydraulic circuit matches the tool for open-center (OC) operation.

### Check Tool

1. Make sure all tool accessories are correctly installed. Failure to install tool accessories properly can result in damage to the tool or personal injury.
2. There should be no signs of leaks.
3. The tool should be clean, with all fittings and fasteners tight.

### Check Trigger Mechanism

1. Check that the trigger operates smoothly and is free to travel between the "ON" and "OFF" positions.

### Install Tool Bit

The CH16 Chipping Hammer accepts standard .580 inch hex shank or .680 round shank tool bits.

### TO INSTALL A HEX SHANK TOOL BIT

1. Slide the chuck outer sleeve toward the handle end of the tool and then insert the tool bit. Release the chuck outer sleeve.

2. Try turning the tool bit. If the tool bit does not turn, no further adjustment is necessary. If the tool bit turns, slide the chuck adjustor toward the tool bit end of the tool and then turn it clockwise to close the hex blocks against the tool bit shank. When the chuck adjustor is properly set, it should "click" into place and the tool bit should not turn.

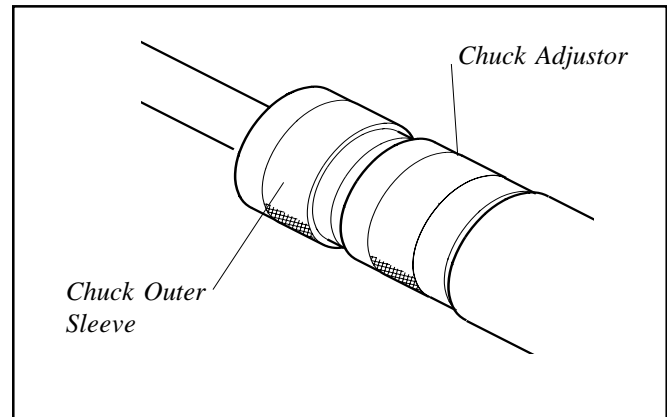

Installing The Tool Bit

### TO INSTALL A ROUND SHANK TOOL BIT

1. Slide the chuck outer sleeve toward the handle end of the tool and then insert the tool bit. Release the chuck outer sleeve.
  2. If the tool bit can be inserted fully, no other adjustments are necessary. If the tool bit cannot be inserted fully, slide the chuck adjustor toward the tool bit end of the tool and then turn it counter clockwise to open the hex blocks and allow room for the tool bit shank. When the chuck adjustor is properly set, it should "click" into place and the tool bit should be fully inserted.
- Connect Hoses

1. Wipe all hose couplers with a clean lint-free cloth before making connections.
2. Connect the hoses from the hydraulic power source to the hose couplers on the tool. It is a good practice to connect the return hose first and disconnect it last to minimize or avoid trapped pressure within the tool.
3. Observe flow indicators stamped on hose couplers to be sure that oil will flow in the proper direction. The female coupler is the inlet coupler.

---

# OPERATION

---

**NOTE:**

**The pressure increase in uncoupled hoses left in the sun may result in making them difficult to connect. When possible, connect the free ends of operating hoses together.**

---

## OPERATING PROCEDURES

---

1. Observe all safety precautions.
2. Move the hydraulic circuit control valve to the "ON" position.
3. Place the tool bit firmly on the surface to be broken.
4. Squeeze the trigger to start the chipping hammer. Adequate down pressure is very important.

**NOTE:**

**Partially depressing the trigger allows the tool to operate at a slow speed, making it easy to start the tool bit into the surface to be broken.**

**CAUTION**

**NOT FOR UNDERWATER USE**

---

## COLD WEATHER OPERATION

---

If the tool is to be used during cold weather, preheat the hydraulic fluid at low engine speed. When using the normally recommended fluids, fluid temperature should be at or above 50° F/10° C (400 ssu/82 centistokes) before use.

**STORAGE**

1. Disconnect the tool from the hydraulic power source.
2. Remove the tool bit and spray the chuck area with WD-40™ inside and out.
3. Wipe clean and store in a clean, dry place.

---

# EQUIPMENT PROTECTION & CARE

---

## NOTICE

In addition to the Safety Precautions on page 4 & 5 of this manual, observe the following for equipment protection and care.

- Make sure all couplers are wiped clean before connection.
- The hydraulic circuit control valve must be in the “OFF” position when coupling or uncoupling hydraulic tools. Failure to do so may result in damage to the quick couples and cause overheating of the hydraulic system.
- Always store the tool in a clean dry space, safe from damage or pilferage.
- Make sure the circuit PRESSURE hose (with male quick disconnect) is connected to the “IN” port. The circuit RETURN hose (with female quick disconnect) is connected to the opposite port. Do not reverse circuit flow. This can cause damage to internal seals.
- Always replace hoses, couplings and other parts with replacement parts recommended by Stanley Hydraulic Tools. Supply hoses must have a minimum working pressure rating of 2500 psi/172 bar.
- Do not exceed the rated flow (see Specifications) page 13 in the manual for correct flow rate and model number. Rapid failure of the internal seals may result.
- Always keep critical tool markings, such as warning stickers and tags legible.
- Do not force a small breaker to do the job of a large breaker.
- Keep tool bit sharp for maximum breaker performance. Make sure that tool bits are not chipped or rounded on the striking end.
- Never operate a breaker without a tool bit or without holding it against the work surface. This puts excessive strain on the breaker foot.
- Tool repair should be performed by experienced personnel only.
- Make certain that the recommended relief valves are installed in the pressure side of the system.
- Do not use the tool for applications for which it was not intended.

# TROUBLESHOOTING

Tool does not run.	Power unit not functioning.	Check power unit for proper flow and pressure 7-9gpm/26-34 lpm, 2000 psi/140 bar for 8 gpm model
	Couplers or hoses blocked.	Remove restriction.
	Pressure and return line hoses reversed at ports.	Be sure hoses are connected to their proper ports.
	Mechanical failure of piston or shuttle valve.	Have inspected and repaired by authorized dealer.
Tool does not hit effectively.	Power unit not functioning.	Check power unit for proper flow and pressure 7-9gpm/26-34 lpm, 2000 psi/140 bar for 8 gpm model
	Couplers or hose blocked.	Remove restriction,
	Fluid too hot (above 140° F / 60° C).	Provide cooler to maintain proper fluid temperature.
	Incorrect tool bit	Ensure tool bit meets specifications
Tool operates slow.	Low oil flow from power unit.	Check power source for proper flow.
	High backpressure.	Check hydraulic system for excessive backpressure and correct as required.

---

# SPECIFICATIONS

---

Oil Flow Range	
CH15521, 5 gpm Model .....	4-6 gpm/15-23 lpm
CH15121, 8 gpm Model .....	7-9 gpm/26-34 lpm
Pressure Range .....	1000-2000 psi/69-140 Bar
Length .....	17 in./43 cm
Weight .....	16 lb./7.25 kg
Tool Bit .....	.580 in. Hex Shank or .680 in. Round Shank
Porting .....	-8 SAE O-ring
Couplers .....	HTMA/EHTMA Flush Face Type Male & Female
Connect Size and Type .....	3/8 in. Male Pipe Adapter
Hose Whips .....	Yes
Maximum Back Pressure .....	250 psi/17 bar
Maximum Fluid Temperature .....	140° F/60° C
Noise Level .....	106 LWA
Vibration Level .....	5.8 m/s <sup>2</sup>

---

# ACCESSORIES

---

Description	Part No.
Bushing Tool Bit, .580 Hex .....	02277
Flat Chisel Bit, 1 in. x 18 in., .580 Hex .....	02278
Bull Point Bit, 1 in. x 18 in., .580 Hex .....	02279
Chisel Bit, 1 in. x 9 in., .580 Hex .....	03690
Chisel Bit, 2 in. x 5 in., .580 Hex .....	03963
Chisel Bit, 1 in. x 14 in., .680 Round .....	02339
Moil Point, 18 in., .680 Round .....	04401
Moil Point, 14 in., .680 Round .....	04901
Chisel Bit, 3 in. x 14 in., .680 Round .....	02330
Chisel Bit, 3 in. x 18 in., .680 Round .....	04402
Bruning Flush Face Coupler Set, 3/8 NPT .....	03971
Bruning Flush Face Coupler Set, 1/2 NPT .....	03974
Aeroquip Flush Face Coupler Set, 3/8 NPT .....	24069
Aeroquip Flush Face Coupler Set, 1/2 NPT .....	24070
Hose, 50 ft. x 1/2 in. ID, wire braid, dual, with couplers .....	31848
Hose, 25 ft. x 1/2 in. ID, wire braid, dual, with couplers .....	31972
Seal Kit .....	35979

---

# SERVICE INSTRUCTIONS

---

Follow the procedures contained in the HYDRAULIC SYSTEM REQUIREMENTS section of this manual to ensure peak performance from the tool. Never disassemble the tool unless proper troubleshooting procedures have isolated the problem to an internal part. Then, only disassemble it to the extent necessary to replace the defective part.



Always determine and correct the cause of the problem prior to reassembly. Further wear and tool failure can result if the original cause is not corrected.

---

## PRIOR TO DISASSEMBLY

---

- Clean the exterior of the tool.
- Obtain a seal kit to replace all seals exposed during disassembly. Note the orientation of seals before removing them. Install new seals in the same position as original seals.

---

## DISASSEMBLY

---

1. Slide the outer chuck sleeve (43) toward the handle and remove the retaining ring (42). Slide off the outer chuck sleeve being careful to catch the 3 steel balls (37). Remove the spring (44), and retaining ring (46).
2. Slide the chuck adjuster off of the shank (36) being careful to not let the hex blocks (38) and springs (35) fall out of the shank. Slide the hex blocks and springs out of the shank.
3. Slide the foam grip (39) off of the shank.
4. Unscrew and remove the capscrews (45).
5. Pull the shank away from the cylinder (29). A soft faced mallet may be required to assist in the shank removal by tapping on the shank.
6. Secure the tool in a bench vise, with the "IN" and "OUT" ports up, clamping on the cylinder. Soft vise jaws are necessary.

7. Remove the pigtail hose assemblies.

**Note:**

**The tool is full of fluid and will drip from the ports when the hoses are removed.**

8. Unscrew and remove the 4 capscrews (23) and set the handle (17) aside being careful to prevent the trigger pin (24), valve sleeve (14), and valve spool (12) from falling out. Remove these items from the handle or body (9) and set them aside.
9. Unscrew and remove the 4 capscrews (16). Remove the body from the cylinder. Tapping on the body with a soft faced mallet may be required to assist in the removal. Be careful to prevent the tube (32) from falling out as it may stay in the body as the body is removed.
10. Remove the tube and the shuttle valve (34) and set them aside.
11. Slide the piston (31) out of the cylinder and set it aside.
12. The trigger (20) may be removed from the handle by driving out the 2 spirol pins (22).
13. Remove all seals and discard them.

---

## INSPECTION OF PARTS

---

### Piston and Cylinder

Inspect the surface of the bore of the cylinder and the surface of the piston for wear, galling, and cracks. A light scuffing or burnishing of surfaces is normal. Check especially for freedom of movement of the parts and that the piston does not stick or bind as it is moved in the cylinder. Coat the parts with hydraulic oil for this test.

If small burrs are found, remove them with 220 grit emery cloth.

If galling or cracks are present, the part(s) must be replaced.

Valve Sleeve and Valve Spool

---

# SERVICE INSTRUCTIONS

---

Inspect the surface of the bore of the valve spool and valve sleeve for galling and cracks. A light scuffing or burnishing of surfaces is normal. Check especially for freedom of movement of the valve spool in the valve sleeve.

If small burrs are found, remove them with 220 grit emery cloth. Do not break or buff the sharp edges of the valve sleeve or valve spool as this will cause the valve to malfunction. If galling or cracks are present, the part(s) must be replaced.

## Hex Block and Chuck Parts

Inspect the hex blocks and chuck parts for damage or excessive wear. Replace any parts that are damaged or worn.

## Fasteners

Inspect all fasteners for wear and cracks. When clean and coated with anti-sieze, the fasteners should thread into their related parts without any effort. If some resistance is encountered, check the threads for dirt particles or damage.

---

## ASSEMBLY

---

### Prior to Assembly

- Clean all parts with a degreasing solvent.
- Ensure that all seals exposed during disassembly are replaced with new parts.
- Apply clean grease or o-ring lubricant to all seals during assembly.
- Obtain a seal kit so that all seals exposed during disassembly can be replaced. **Note:** For orientation of parts identified in the following procedures, see the parts illustration.

1. Apply grease and install a new cup seal (28) into the cylinder with the lips of the seal facing toward the handle end of the cylinder. See figure 1.

2. Apply grease and install a new scraper (27) into the cylinder with the lips of the seal facing toward the handle end of the cylinder. See figure 1.

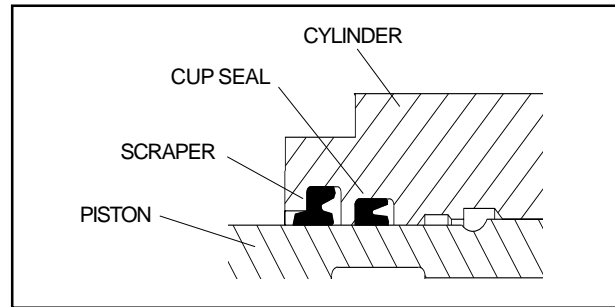

Figure 1.

3. Apply grease and install a new o-ring (30) onto the cylinder.

4. Place the cylinder (29) into a vice with soft jaws. Coat the cylinder bore and piston (31) with clean hydraulic fluid. Insert the piston into the cylinder.

5. Install the dowel pin (33) into the tube (32). See figure 2.

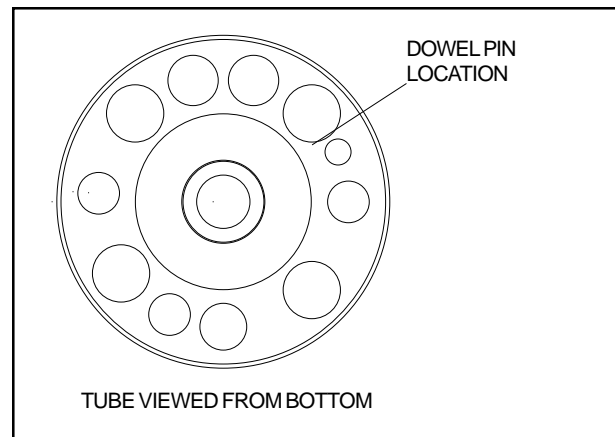

Figure 2.

6. Install the tube with dowel pin installed onto the cylinder. See figure 3.

# SERVICE INSTRUCTIONS

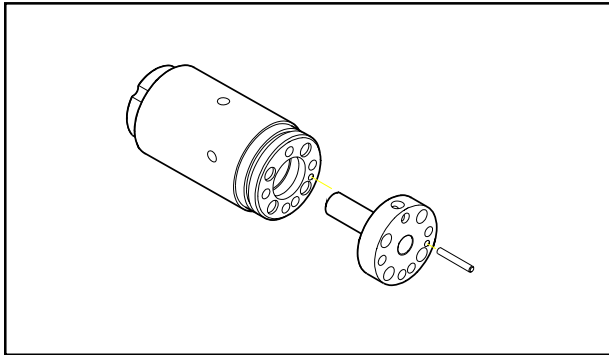

Figure 3

7. Lubricate with clean hydraulic fluid and install the shuttle valve (34) into the tube.

8. Install the body (9) over the tube and shuttle valve onto the cylinder. Ensure the shuttle valve and roll pin are correctly aligned with holes in the body. See figure 4. Use a soft faced mallet to tap the body onto the cylinder.

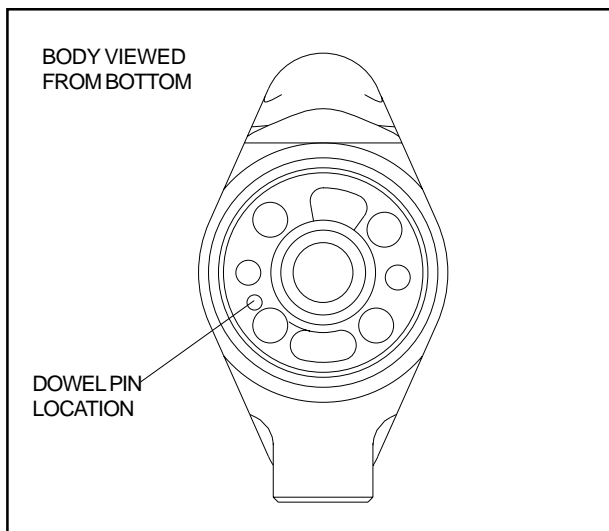

Figure 4.

9. Install the 4 capscrews (16) and tighten to 25 ft. lbs.

10. Apply grease and install a new o-ring (15) onto the valve sleeve (14).

11. Apply grease and install a new o-ring (13) onto the valve spool (12).

12. Lubricate the valve spool and valve sleeve with clean hydraulic fluid. Insert the valve spool into the valve sleeve. Install the insert (11) onto the valve sleeve. Install a new o-ring (10) around the outer diameter of the insert. Insert this assembly into the body. See figure 5.

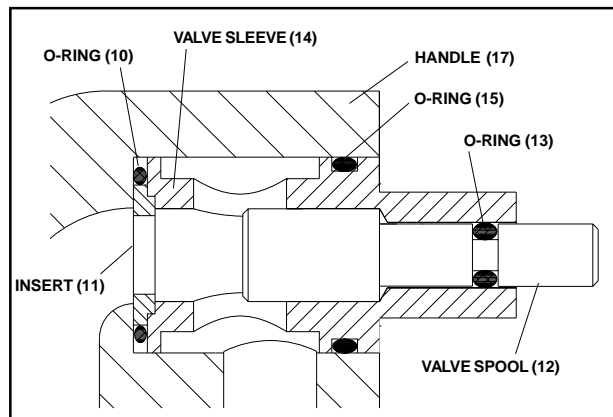

Figure 5.

13. Apply grease and install 4 o-rings (15) into the grooves surrounding the capscrew (16) holes in the body.

14. Apply a light coat of grease to the trigger pin (24) and install it into the handle. Install the handle onto the body using 4 capscrews (23). Tighten to 25 ft. lbs.

**NOTE:**

**If the trigger was disassembled from the handle, reinstall it before installing the handle to the body.**

15. Apply grease and install a new o-ring (6) into the groove on the control shaft.

16. Install the shank (36) to the cylinder. Apply Loctite™ and install 4 capscrews (45). Tighten to 15 ft. lb. There is no special alignment of the shank to the cylinder. Use the parts drawing as a guide for alignment.

17. Install the foam grip (39) over the shank and cylinder.

18. Apply Kopr-Kote™ to the springs (35) and insert each of them into a hole in one of the hex block (38) halves. Install the other hex block half over the springs and then install the assembly into the slot in the shank



---

# SERVICE INSTRUCTIONS

---

and hold it in place with one hand. Obtain the chuck adjuster (40) and turn it so that the end containing 4 channels is facing toward the handle. Slide the chuck adjuster onto the shank and over the slot containing the hex blocks and springs.

19. Apply grease and install the 3 steel balls (37). Install the retaining ring (46), the spring (44), outer chuck (43) and retaining ring (42).

20. Install the hose assemblies (47) making sure the female coupler is installed to the "IN" port and the male coupler is installed to the "OUT" port.

---

## TESTING FOR OPERATION AND PERFORMANCE

---

1. Install a tool bit.
2. Connect the tool to a hydraulic power source.
3. Operate the tool with the bit pressed against a hard surface. The tool should not stall.
4. Turn the tool "ON" and "OFF" several times to ensure the valve is operating correctly.
5. Test the speed control by moving the speed adjuster lever back and forth.

---

## STORAGE

---

1. Disconnect the tool from the hydraulic power source.
2. Remove the tool bit and spray the chuck area with WD-40™ inside and out.
3. Wipe clean and store in a clean, dry place.

# CH15 PARTS ILLUSTRATION

CH15121, 8 GPM Model  
CH15521, 5 GPM Model  
CH1532101, 8 GPM Model

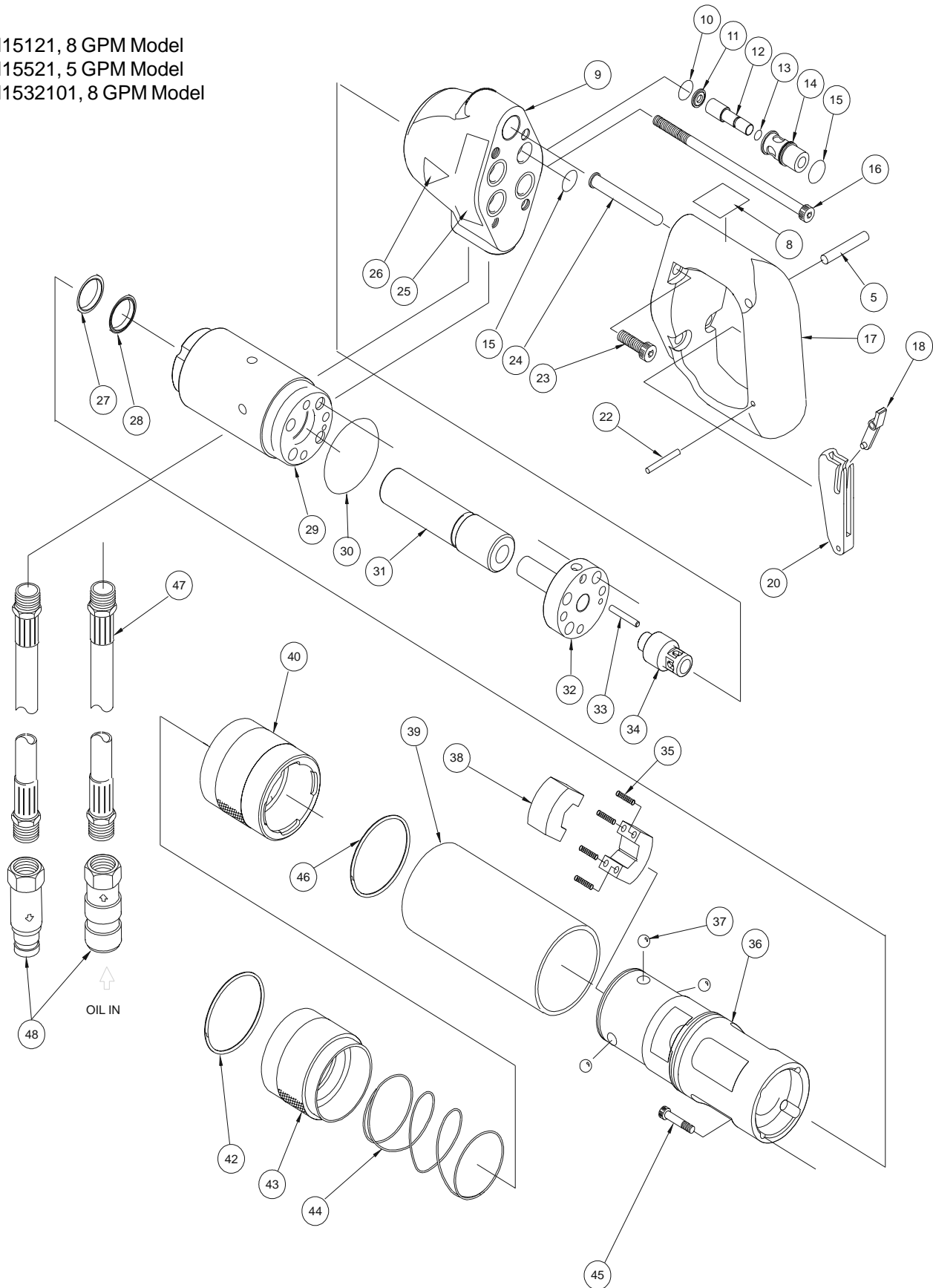

# CH15 PARTS LIST

ITEM	P/N	QTY	DESCRIPTION
1	----	--	NO ITEM
2	----	--	NO ITEM
3	----	--	NO ITEM
4	----	--	NO ITEM
5	07492	1	SPIROL PIN
6	28323	1	CE STICKER
7	11211	1	SOUND PWR LEVEL STICKER
8	28409	1	COMPOSITE STICKER
9	35544	1	BODY
10	00016	1	O-RING 2-015 R16
11	33268	1	INSERT
12	31583	1	VALVE SPOOL
13	31650	1	O-RING, .176x.040, 5 -193
14	31597	1	VALVE SLEEVE
15	01211	5	O-RING 2-016 R16
16	24871	4	CAPSCREW 5/16-18UNC x 3
17	35533	1	HANDLE
18	62197	1	TRIGGER ROD
19	----	--	NO ITEM
20	62198	1	TRIGGER
21	00878	1	DOWEL PIN, 3/16 X 1/2 SS
22	31602	1	SPIROL PIN 5/32 x 1.2
23	13815	4	CAPSCREW 5/16-18UNC x 1
24	31582	1	TRIGGER PIN
25	33513	1	NAME TAG, CH15521 MODEL
	36112	1	NAME TAG, CH15121 MODEL
26	11206	1	CIRCUIT "C" STICKER, CH15521MODEL
	11207	1	CIRCUIT "D" STICKER, CH15121MODEL
27	31607	1	SCRAPER
28	31606	1	CUP SEAL
29	36111	1	CYLINDER, CH15121 MODEL
	35961	1	CYLINDER, CH15521 MODEL
30	07572	1	O-RING 2-135 R16
31	33520	1	PISTON, CH15121 MODEL
	31590	1	PISTON, CH15521 MODEL
32	33521	1	TUBE, CH15121 MODEL
	35547	1	TUBE, CH15521 MODEL
33	35546	1	DOWEL PIN, 5/32 X 1.500
34	31592	1	SHUTTLE VALVE
35	33293	4	SPRING
36	31585	1	SHANK
	38596	1	SHANK - UNDERWATER MODEL ONLY
37	12100	3	STEEL BALL 3/8 DIA. G
38	31586	2	HEX BLOCK
39	33294	1	FOAM GRIP
40	31587	1	CHUCK ADJUSTOR
41	----	--	NO ITEM
42	33292	1	RETAINING RING
43	31588	1	CHUCK OUTER SLEEVE
44	33291	1	SPRING
45	35976	4	CAPSCREW 1/4X1.500
46	38597	1	RETAINING RING - U/W MODEL ONLY
47	01412	2	PIGTAIL HOSE ASSY 12
48	03971	1	FLUSH FACE COUPLER SET

MODEL DESIGNATIONS	
CH15521	5 gpm Model
CH15121	8 gpm Model

<b>SEAL KIT</b>	35979
-----------------	-------

---

# WARRANTY

---

Stanley Hydraulic Tools (hereinafter called "Stanley"), subject to the exceptions contained below, warrants new hydraulic tools for a period of one year from the date of sale to the first retail purchaser, or for a period of 2 years from the shipping date from Stanley, whichever period expires first, to be free of defects in material and/or workmanship at the time of delivery, and will, at its option, repair or replace any tool or part of a tool, or new part, which is found upon examination by a Stanley authorized service outlet or by Stanley's factory in Milwaukee, Oregon to be DEFECTIVE IN MATERIAL AND/OR WORKMANSHIP.

## EXCEPTIONS FROM WARRANTY

**FREIGHT COSTS:** Freight costs to return parts to Stanley, if requested by Stanley for the purpose of evaluating a warranty claim for warranty credit, are covered under this policy if the claimed part or parts are approved for warranty credit. Freight costs for any part or parts which are not approved for warranty credit will be the responsibility of the individual.

**SEALS & DIAPHRAGMS:** Seals and diaphragms installed in new tools are warranted to be free of defects in material and/or workmanship for a period of 6 months after the date of first usage, or for a period of 2 years from the shipping date from Stanley, whichever period expires first.

**CUTTING ACCESSORIES:** Cutting accessories such as breaker tool bits are warranted to be free of defects in material and or workmanship at the time of delivery only.

**ITEMS PRODUCED BY OTHER MANUFACTURERS:** Components which are not manufactured by Stanley and are warranted by their respective manufacturers.

- a. Costs incurred to remove a Stanley manufactured component in order to service an item manufactured by other manufacturers.

**ALTERATIONS & MODIFICATIONS:** Alterations or modifications to any tool or part. All obligations under this warranty shall be terminated if the new tool or part is altered or modified in any way.

**NORMAL WEAR:** any failure or performance deficiency attributable to normal wear and tear such as tool bushings, retaining pins, wear plates, bumpers, retaining rings and plugs, rubber bushings, recoil springs, etc.

**INCIDENTAL/CONSEQUENTIAL DAMAGES:** To the fullest extent permitted by applicable law, in no event will STANLEY be liable for any incidental, consequential or special damages and/or expenses.

**FREIGHT DAMAGE:** Damage caused by improper storage or freight handling.

**LOSS TIME:** Loss of operating time to the user while the tool(s) is out of service.

**IMPROPER OPERATION:** Any failure or performance deficiency attributable to a failure to follow the guidelines and/or procedures as outlined in the tool's operation and maintenance manual.

**MAINTENANCE:** Any failure or performance deficiency attributable to not maintaining the tool(s) in good operating condition as outlined in the Operation and Maintenance Manual.

**HYDRAULIC PRESSURE & FLOW:** Any failure or performance deficiency attributable to excess hydraulic pressure, excess hydraulic back-pressure, or excess hydraulic flow.

**REPAIRS OR ALTERATIONS:** Any failure or performance deficiency attributable to repairs by anyone which in Stanley's sole judgement caused or contributed to the failure or deficiency.

**MIS-APPLICATION:** Any failure or performance deficiency attributable to mis-application. "Mis-application" is defined as usage of products for which they were not originally intended or usage of products in such a manner which exposes them to abuse or accident, without first obtaining the written consent of Stanley.

**WARRANTY REGISTRATION:** STANLEY ASSUMES NO LIABILITY FOR WARRANTY CLAIMS SUBMITTED FOR WHICH NO TOOL REGISTRATION IS ON RECORD. In the event a warranty claim is submitted and no tool registration is on record, no warranty credit will be issued without first receiving documentation which proves the sale of the tool or the tools' first date of usage. The term "DOCUMENTATION" as used in this paragraph is defined as a bill of sale, or letter of intent from the first retail customer. A WARRANTY REGISTRATION FORM THAT IS NOT ALSO ON RECORD WITH STANLEY WILL NOT BE ACCEPTED AS "DOCUMENTATION".

## NO ADDITIONAL WARRANTIES OR REPRESENTATIONS

This limited warranty and the obligation of Stanley thereunder is in lieu of all other warranties, expressed or implied including merchantability or fitness for a particular purpose except for that provided herein. There is no other warranty. This warranty gives the purchaser specific legal rights and other rights may be available which might vary depending upon applicable law.



**Stanley Hydraulic Tools**  
3810 SE Naef Road  
Milwaukie OR 97267-5698  
503-659-5660  
FAX 503-652-1780  
[www.stanley-hydraulic-tools.com](http://www.stanley-hydraulic-tools.com)

---