

BR47/48

Hydraulic Breaker

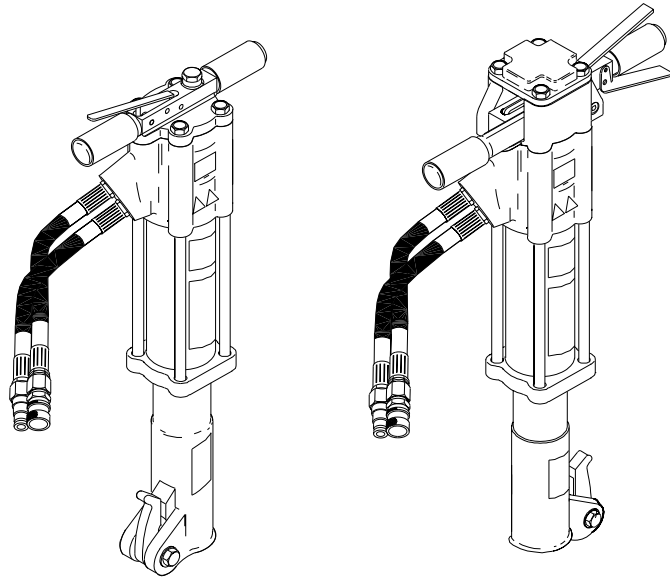

⚠ WARNING

SERIOUS INJURY OR DEATH
COULD RESULT FROM THE
IMPROPER REPAIR OR
SERVICE OF THIS TOOL.

REPAIRS AND/OR SERVICE TO
THIS TOOL MUST ONLY BE
DONE BY AN AUTHORIZED AND
CERTIFIED DEALER.



Read The Manual Wear Breathing Protection Wear Hearing Protection Wear Eye Protection

Safety, and Operation User's Manual

STANLEY®



Copyright © 2001 The Stanley Works
OPS & CE Version USA
59132 02/03 Ver. 2

Stanley Hydraulic Tools
3810 SE Naef Road
Milwaukie, OR 97267-5698 USA
Phone: (503) 659-5660
Fax: (503) 652-1780

Table of Contents

BR47/48 Hydraulic Breaker

Servicing The BR47/48 Hydraulic Breaker:

This manual contains Safety, Operation, and Troubleshooting information. Stanley Hydraulic Tools recommends that servicing of hydraulic tools, other than routine maintenance, must be performed by an authorized and certified dealer. Please read the WARNING on the cover and the SAFETY warning below.

Contents	1
Certificate of Conformity (BR47)	2
Certificate of Conformity (BR48)	3
Specifications	4
General Safety Instructions	5,6
Tools Decals and Tags	7
Hydraulic Hose Requirements	8
HTMA Requirements	9
Equipment Protection and Care	10
Operating Instructions	11
Troubleshooting	12,13
Maintenance	14,15
Parts Illustration	17,19
Parts List	16,18
Accessories	20
Warranty	21

Copyright©2001 The Stanley Works
All rights reserved.

Under copyright law, this document may not be copied in whole or in part without the prior written consent of The Stanley Works. This exception does not permit copies to be made for others, whether or not sold. Under the law, copying includes translating into another language, format or medium. This copyright notice must appear on any permitted copies.

SAFETY FIRST

It is the responsibility of the operator and service technician to read rules and instructions for safe and proper operation and maintenance.

A cautious worker using common sense is the greatest safety device.

CERTIFICATE OF CONFORMITY



I, the undersigned:

Winterling, David

Surname and First names

Hereby certify that the construction plant or equipment specified hereunder:

1. Manufacturer: **Stanley Hydraulic Tools, 3810 SE Naef Road, Milwaukie, Oregon USA**
2. Representative in the Union: **Stanley Svenska AB, Box 9054, 400 92 Göteborg, SWEDEN**
3. Category: **Hydraulic Hand Held Concrete Breaker**
4. Make: **Stanley Hydraulic Tools**
5. Type: **BR47**
6. Type serial number of equipment: **ALL**
7. Year of Manufacture: **Beginning 2002**

Has been manufactured in conformity with the provisions of the Machinery Directive 98/37/EC

Harmonized standard applied: **EN 792-4**

We also declare that it meets the specification of Noise Directive 2000/14/EC, measured in accordance to the Conformity Evaluation Method set out in Annex VI para. 5 and evaluated during production as in Annex VI para. 6, 2nd procedure.

8. Noise related value: **25 kg**
9. Measured sound power on equipment representative of this type: **106 LwA**
10. Guaranteed sound power level for this equipment: **109 LwA**
11. Notified body for EC directive 2000/14/EC: **0404**

SMP Svensk Maskinprovning AB
Fyrisborgsgatan 3
754 50 Uppsala, SWEDEN

12. Special Provisions: **None**

Issued at Stanley Hydraulic Tools, Milwaukie, Oregon USA

Date: 8/21/02

Signature:

A handwritten signature in black ink, appearing to read "David Winterling".

Position: Engineering Manager

CERTIFICATE OF CONFORMITY



I, the undersigned:

Winterling, David

Surname and First names

Hereby certify that the construction plant or equipment specified hereunder:

1. Manufacturer: **Stanley Hydraulic Tools, 3810 SE Naef Road, Milwaukie, Oregon USA**
2. Representative in the Union: **Stanley Svenska AB, Box 9054, 400 92 Göteborg, SWEDEN**
3. Category: **Hydraulic Hand Held Concrete Breaker**
4. Make: **Stanley Hydraulic Tools**
5. Type: **BR48**
6. Type serial number of equipment: **ALL**
7. Year of Manufacture: **Beginning 2002**

Has been manufactured in conformity with the provisions of the Machinery Directive 98/37/EC

Harmonized standard applied: **EN 792-4**

We also declare that it meets the specification of Noise Directive 2000/14/EC, measured in accordance to the Conformity Evaluation Method set out in Annex VI para. 5 and evaluated during production as in Annex VI para. 6, 2nd procedure.

8. Noise related value: **25 kg**
9. Measured sound power on equipment representative of this type: **106 LwA**
10. Guaranteed sound power level for this equipment: **109 LwA**
11. Notified body for EC directive 2000/14/EC: **0404**

SMP Svensk Maskinprovning AB
Fyrisborgsgatan 3
754 50 Uppsala, SWEDEN

12. Special Provisions: **None**

Issued at Stanley Hydraulic Tools, Milwaukie, Oregon USA

Date: 8/21/02

Signature:

A handwritten signature in black ink, appearing to read "David Winterling".

Position: Engineering Manager

Specifications

Pressure Range.....1500-2000psi/105-140bar

Flow Range.....
BR4757201 & BR4857801.....(HTMA-I)



.....5-6 gpm/18-22lpm

BR4817801.....(HTMA-II)



.....7-9gpm/26-34lpm

Optimum Flow.....5gpm/20lpm
.....OR8gpm/30lpm

Maximum Back Pressure.....250 Psi/17bar

Couplers..... HTMA Flush Face
Per NFPA 3.20.15/ISO 16028

Connect Size & Type_3/8 in. Male Pipe Hose Ends

Hose Whips.....Yes

Weight.....BR47-48lbs./21.7kg

.....BR48-53 lbs./24kg

Overall Length.....BR47-27in./686mm.

.....BR48-28.5 in./724mm

Overall Width.....BR47-13.750in./349mm

.....BR48-17.25 in./438mm

Overall Height.....BR47/48-4.3 in./11 cm

Max. Fluid Temp.....140°F/60°C

System Type.....Open Or Closed Center

Port Size.....SAE 80-ring

Noise Level At Operator.....98dBA

Vibration Level.....

.....BR47, 13.2m/sec²

.....BR48, 9.9m/sec²

NOTE

Weights, dimensions and operating specifications listed are subject to change without notice. Where specifications are critical to your application, please consult the factory.

SAFETY SYMBOLS

Safety symbols and signal words, as shown below, are used to emphasize all operator, maintenance and repair actions which, if not strictly followed, could result in a life-threatening situation, bodily injury or damage to equipment.



This is the safety alert symbol. It is used to alert you to potential personal injury hazards. Obey all safety messages that follow this symbol to avoid possible injury or death.



This safety alert and signal word indicate an imminently hazardous situation which, if not avoided, will result in death or serious injury.



This safety alert and signal word indicate a potentially hazardous situation which, if not avoided, could result in death or serious injury.



This safety alert and signal word indicate a potentially hazardous situation which, if not avoided, may result in minor or moderate injury.



This signal word indicates a potentially hazardous situation which, if not avoided, may result in property damage.



This signal word indicates a situation which, if not avoided, will result in damage to the equipment.



This signal word indicates a situation which, if not avoided, may result in damage to the equipment.

Always observe safety symbols. They are included for your safety and for the protection of the tool.

WARNING

SOME HYDRAULIC FLUIDS ARE FLAMMABLE, NEVER ALLOW THESE HYDRAULIC FLUIDS TO COME IN CONTACT WITH AN OPEN FLAME.

IF A HOSE WERE TO BURST OR IF A TOOL LEAK OCCURS NEXT TO AN OPEN FLAME, THESE HYDRAULIC FLUIDS WILL IGNITE AND COULD RESULT IN SERIOUS INJURY OR DEATH.

LOCAL SAFETY REGULATIONS

Enter any local safety regulations here. Keep these instructions in an area accessible to the operator and maintenance personnel.

General Safety Instructions



Tool operators and maintenance personnel must always comply with the safety precautions given in this manual and on the stickers and tags attached to the tool and hose.

These safety precautions are given for your safety. Review them carefully before operating the tool and before performing general maintenance or repairs.

Supervising personnel should develop additional precautions relating to the specific work area and local safety regulations. If so, place the added precautions in the space provided on page 5.

This tool will provide safe and dependable service if operated in accordance with the instructions given in this manual. Read and understand this manual and any stickers and tags attached to the tool and hoses before operation. Failure to do so could result in personal injury or equipment damage.

- ⚠ Operator must start in a work area without bystanders. The operator must be familiar with all prohibited work areas such as excessive slopes and dangerous terrain conditions.
- ⚠ Establish a training program for all operators to ensure safe operations.
- ⚠ Do not operate the tool unless thoroughly trained or under the supervision of an instructor.
- ⚠ Always wear safety equipment such as goggles, head protection, and safety shoes at all times when operating the tool.
- ⚠ Do not inspect or clean the tool while the hydraulic power source is connected. Accidental engagement of the tool can cause serious injury.
- ⚠ Do not operate this tool without first reading the Operating Instructions.
- ⚠ Do not install or remove Parts on this tool while the hydraulic power source is connected. Accidental engagement of the tool can cause serious injury.
- ⚠ Never operate the tool if you cannot be sure that underground utilities are not present. Underground electrical utilities present an electrocution hazard. Underground gas utilities present an explosion hazard. Other underground utilities may present other hazards.
- ⚠ Do not wear loose fitting clothing when operating the tool. Loose fitting clothing can get entangled with the tool and cause serious injury.
- ⚠ Supply hoses must have a minimum working pressure rating of 2500 psi/175 bar.
- ⚠ Be sure all hose connections are tight.
- ⚠ The hydraulic circuit control valve must be in the “OFF” position when coupling or uncoupling the tool. Wipe all couplers clean before connecting. Failure to do so may result in damage to the quick couplers and cause overheating. Use only lint-free cloths.
- ⚠ Do not operate the tool at oil temperatures above 140° F/60° C. Operation at higher oil temperatures can cause operator discomfort and may cause damage to the tool.
- ⚠ Do not operate a damaged, improperly adjusted, or incompletely assembled tool.
- ⚠ To avoid personal injury or equipment damage, all tool repair, maintenance and service must only be performed by authorized and properly trained personnel.
- ⚠ Do not exceed the rated limits of the tool or use the tool for applications beyond its design capacity.
- ⚠ Always keep critical tool markings, such as labels and warning stickers legible.
- ⚠ Always replace parts with replacement parts recommended by Stanley Hydraulic Tools.
- ⚠ Check fastener tightness often and before each use daily.

Tool Decals & Tags

A Model Number Sticker is attached to the tool. Never exceed the flow and pressure levels specified on this sticker. The information listed on the Model Number sticker must be legible at all times. Replace this sticker if it becomes worn or damaged. A replacement is available from your local Stanley distributor.



11207
Circuit "D" Label



11206
Circuit "C" Label



58603
Guaranteed Sound Power
Level Sticker

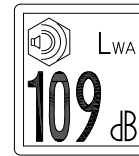

28409
Composite
Safety Label



28411 BR48 Model No.
28410 BR47 Model No.

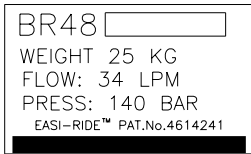

28376
Name Tag

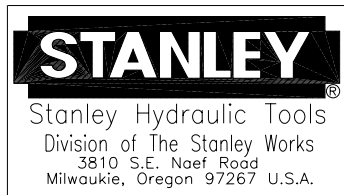

11208
Hex Shank Length
Label

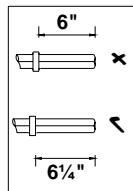

DANGER

1. FAILURE TO USE HYDRAULIC HOSE LABELED AND CERTIFIED AS NON-CONDUCTIVE WHEN USING HYDRAULIC TOOLS ON OR NEAR ELECTRICAL LINES MAY RESULT IN DEATH OR SERIOUS INJURY.

BEFORE USING HOSE LABELED AND CERTIFIED AS NON-CONDUCTIVE ON OR NEAR ELECTRICAL LINES BE SURE THE HOSE IS MAINTAINED AS NON-CONDUCTIVE. THE HOSE SHOULD BE REGULARLY TESTED FOR ELECTRIC CURRENT LEAKAGE IN ACCORDANCE WITH YOUR SAFETY DEPARTMENT INSTRUCTIONS.

2. A HYDRAULIC LEAK OR BURST MAY CAUSE OIL INJECTION INTO THE BODY OR CAUSE OTHER SEVERE PERSONAL INJURY.

A. DO NOT EXCEED SPECIFIED FLOW AND PRESSURE FOR THIS TOOL. EXCESS FLOW OR PRESSURE MAY CAUSE A LEAK OR BURST.

B. DO NOT EXCEED RATED WORKING PRESSURE OF HYDRAULIC HOSE USED WITH THIS TOOL. EXCESS PRESSURE MAY CAUSE A LEAK OR BURST.

C. CHECK TOOL, HOSE, COUPLERS & CONNECTORS DAILY FOR LEAKS. DO NOT FEEL FOR LEAKS WITH YOUR HANDS. CONTACT WITH A LEAK MAY RESULT IN SEVERE PERSONAL INJURY.

IMPORTANT

READ OPERATION MANUAL AND SAFETY INSTRUCTIONS FOR THIS TOOL BEFORE USING IT.

USE ONLY PARTS AND REPAIR PROCEDURES APPROVED BY STANLEY AND DESCRIBED IN THE OPERATION MANUAL.

TAG TO BE REMOVED ONLY BY TOOL OPERATOR.

(517) SEE OTHER SIDE 15875

DANGER

D. DO NOT LIFT OR CARRY TOOL BY THE HOSES. DO NOT ABUSE HOSE. DO NOT USE KINKED, TORN OR DAMAGED HOSES.

3. MAKE SURE HYDRAULIC HOSES ARE PROPERLY CONNECTED TO THE TOOL BEFORE PRESSURIZING SYSTEM. SYSTEM PRESSURE HOSE MUST ALWAYS BE CONNECTED TO TOOL "IN" PORT. SYSTEM RETURN HOSE MUST ALWAYS BE CONNECTED AT TOOL "OUT" PORT. REVERSING CONNECTIONS MAY CAUSE REVERSE TOOL OPERATION WHICH CAN CAUSE SEVERE PERSONAL INJURY.

4. DO NOT CONNECT CLOSED-CENTER TOOLS TO OPEN-CENTER HYDRAULIC SYSTEMS. THIS MAY CAUSE EXTREME SYSTEM HEAT AND/OR SEVERE PERSONAL INJURY.

DO NOT CONNECT OPEN-CENTER TOOLS TO CLOSED-CENTER HYDRAULIC SYSTEMS. THIS MAY RESULT IN LOSS OF OTHER HYDRAULIC FUNCTIONS POWERED BY THE SAME SYSTEM AND/OR SEVERE PERSONAL INJURY.

5. BYSTANDERS MAY BE INJURED IN YOUR WORK AREA. KEEP BYSTANDERS CLEAR OF YOUR WORK AREA.

6. WEAR HEARING, EYE, FOOT, HAND AND HEAD PROTECTION.

7. TO AVOID PERSONAL INJURY OR EQUIPMENT DAMAGE, ALL TOOL REPAIR, MAINTENANCE AND SERVICE MUST BE PERFORMED BY AUTHORIZED AND PROPERLY TRAINED PERSONNEL.

IMPORTANT

READ OPERATION MANUAL AND SAFETY INSTRUCTIONS FOR THIS TOOL BEFORE USING IT.

USE ONLY PARTS AND REPAIR PROCEDURES APPROVED BY STANLEY AND DESCRIBED IN THE OPERATION MANUAL.

TAG TO BE REMOVED ONLY BY TOOL OPERATOR.

(517) SEE OTHER SIDE 15875

The SAFETY TAG, P/N 15875, shown at right, smaller than actual size, is attached to the tool when shipped from the factory. Read and understand the safety instructions listed on this tag before removal. We suggest you retain this tag and attach it to the tool when not in use.

Hydraulic Hose Requirements

HOSE TYPES

Hydraulic hose types authorized for use with Stanley Hydraulic Tools are as follows:

- ① Certified non-conductive
- ② Wire-braided (conductive)
- ③ Fabric-braided (not certified or labeled non-conductive)

Hose ① listed above is the only hose authorized for use near electrical conductors.

Hoses ② and ③ listed above are **conductive** and **must never** be near electrical conductors.

HOSE SAFETY TAGS

To help ensure your safety, the following DANGER tags are attached to all hoses purchased from Stanley Hydraulic Tools. **DO NOT REMOVE THESE TAGS.**

If the information in a tag is illegible because of wear or damage, replace the tag immediately. A new tag may be obtained at no charge from your Stanley Distributor.

This Tag attached to “Certified Non-Conductive” hose.

(shown smaller than actual size) p/n 27987

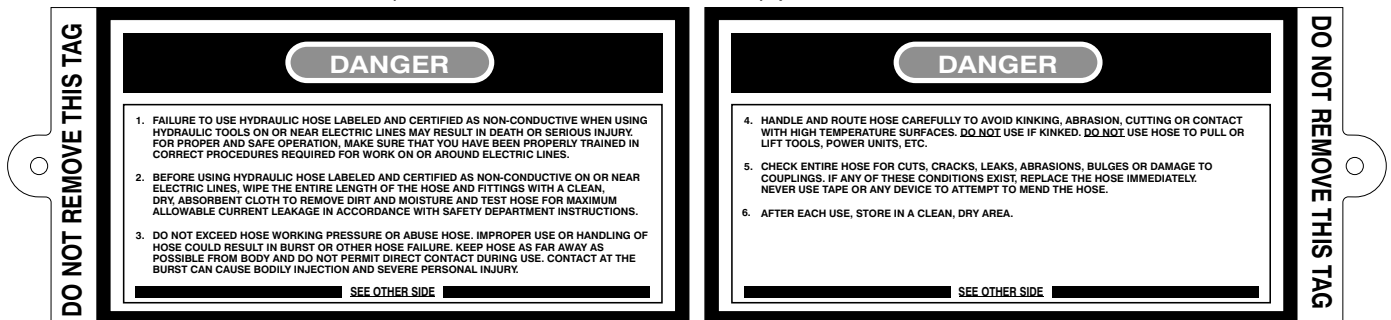

Side 1

Side 2

This Tag attached to “Conductive” hose.

(shown smaller than actual size) p/n 29144

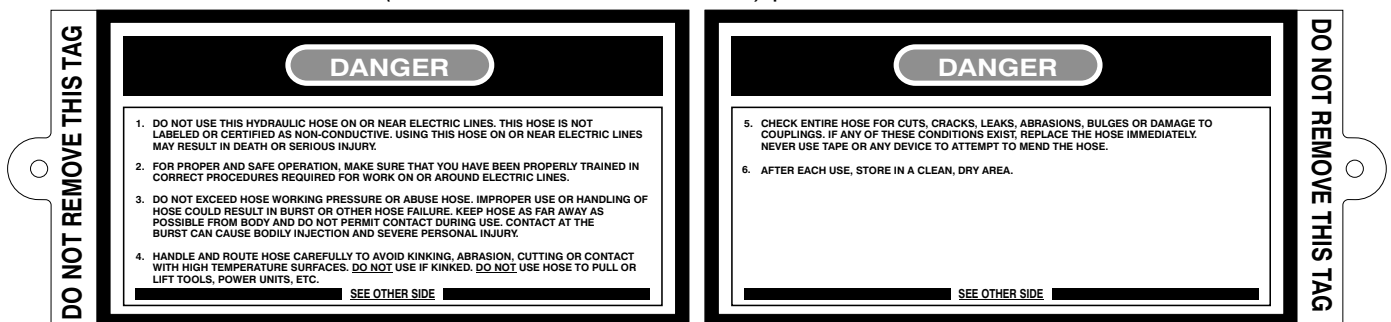

Side 1

Side 2



HOSE PRESSURE RATING

The rated working pressure of the hydraulic hose must be equal to or higher than the relief valve setting on the hydraulic system.

NOTICE

These are general hydraulic system requirements. See tool specifications page for tool specific requirements.

HTMA Requirements

Hydraulic System Requirements	Tool Category:  Type I	 Type II	Type III	Type RR
Flow rate Tool Operating Pressure <i>(at the power supply outlet)</i>	4-6 GPM (15-23 lpm) 2000 psi (138 bar)	7-9 GPM (26-34 lpm) 2000 psi (138 bar)	11-13 GPM (42-49 lpm) 2000 psi (138 bar)	9-10.5 GPM (34-40 lpm) 2000 psi (138 bar)
System relief valve setting <i>(at the power supply outlet)</i>	2100-2250 (145-155 bar)	2100-2250 (145-155 bar)	2100-2250 (145-155 bar)	2200-2300 (152-159 bar)
Maximum back pressure <i>(at tool end of the return hose)</i>	250 psi (17 bar)	250 psi (17 bar)	250 psi (17 bar)	250 psi (17 bar)
Measured at a max. fluid viscosity of: <i>(at min. operating temperature)</i>	400 SSU (82 centistokes)	400 SSU (82 centistokes)	400 SSU (82 centistokes)	400 SSU (82 centistokes)
Temperature Sufficient heat rejection capacity to limit max. fluid temperature to: <i>(at max. expected ambient temperature)</i>	140° F (60° C)	140° F (60° C)	140° F (60° C)	140° F (60° C)
Min. cooling capacity at a temperature difference of between ambient and fluid temps	3 hp (2.24 kW) 40° F (22° C)	5 hp (3.73 kW) 40° F (22° C)	7 hp (5.22 kW) 40° F (22° C)	6 hp (4.5 kW) 40° F (22° C)
NOTE: Do not operate the tool at oil temperatures above 140 ° F (60° C). Operation at higher temperatures can cause operator discomfort at the tool.				
Filter Min. full-flow filtration sized for flow of at least: <i>(For cold temp. startup and max. dirt-holding capacity)</i>	25 microns 30 GPM (114 lpm)	25 microns 30 GPM (114 lpm)	25 microns 30 GPM (114 lpm)	25 microns 30 GPM (114 lpm)
Hydraulic fluid Petroleum based <i>(premium grade, anti-wear, non-conductive)</i>				
Viscosity <i>(at min. and max. operating temps)</i>	100-400 SSU* (20-82 centistokes)	100-400 SSU* (20-82 centistokes)	100-400 SSU* (20-82 centistokes)	100-400 SSU* (20-82 centistokes)
NOTE: When choosing hydraulic fluid, the expected oil temperature extremes that will be experienced in service determine the most suitable temperature viscosity characteristics. Hydraulic fluids with a viscosity index over 140 will meet the requirements over a wide range of operating temperatures.				

*SSU = Saybolt Seconds Universal

NOTE: These are general hydraulic system requirements. See tool Specification page for tool specific requirements.

Equipment Protection and Care

IMPORTANT

In addition to the Safety Precautions on page 5 & 6 of this manual, observe the following for equipment protection and care.

- Make sure all couplers are wiped clean before connection.
- The hydraulic circuit control valve must be in the “OFF” position when coupling or uncoupling hydraulic tools. Failure to do so may result in damage to the quick couples and cause overheating of the hydraulic system.
- Always store the tool in a clean dry space, safe from damage or pilferage.
- Make sure the circuit PRESSURE hose (with male quick disconnect) is connected to the “IN” port. The circuit RETURN hose (with female quick disconnect) is connected to the opposite port. Do not reverse circuit flow. This can cause damage to internal seals.
- Always replace hoses, couplings and other parts with replacement parts recommended by Stanley Hydraulic Tools. Supply hoses must have a minimum working pressure rating of 2500 psi/172 bar.
- Do not exceed the rated flow (see Specifications) page 4 in the manual for correct flow rate and model number. Rapid failure of the internal seals may result.
- Always keep critical tool markings, such as warning stickers and tags legible.
- Do not force a small breaker to do the job of a large breaker.
- Keep tool bit sharp for maximum breaker performance. Make sure that tool bits are not chipped or rounded on the striking end.
- Never operate a breaker without a tool bit or without holding it against the work surface. This puts excessive strain on the breaker foot.
- Tool repair should be performed by experienced personnel only.
- Make certain that the recommended relief valves are installed in the pressure side of the system.
- Do not use the tool for applications for which it was not intended.

Operating Instructions

The recommended hose size is .500 inch/12 mm I.D. up to 50 ft/15 m long and .625 inch/16 mm I.D. minimum up to 100 ft/30 m.

Pre-Operation Procedures

Check Power Source

1. Using a calibrated flowmeter and pressure gauge, check that the hydraulic power source develops a flow of 7-9 gpm/26-34 lpm at 2000 psi/140 bar. 5-6 gpm /18-22 lpm at 1500-2000 psi /105-140 bar.
2. Make certain the hydraulic power source is equipped with a relief valve set to open at 2250 psi/155 bar maximum.

Install Tool Bit

1. Rotate the latch on the breaker foot downward (pointing away from the tool).
2. Insert the tool bit into the foot and pull the latch up to lock the tool bit in place.

Connect Hoses

1. Wipe all hose couplers with a clean, lint-free cloth before making connections.
2. Connect the hoses from the hydraulic power source to the tool fittings or quick disconnects. It is a good practice to connect return hoses first and disconnect them last to minimize or avoid trapped pressure within the tool.
3. Observe flow indicators stamped on hose couplers to ensure that fluid flow is in the proper direction. The female coupler on the tool hose is the inlet coupler.
4. Move the hydraulic circuit control valve to the **ON** position to operate the tool.

NOTE: If uncoupled hoses are left in the sun, pressure increase within the hoses may make them difficult to connect. When possible, connect the free ends of the hoses together.

Operation Procedures

1. Observe all safety precautions.

3. Place the bit firmly on the surface to be broken.
4. Squeeze the trigger to start the breaker. Adequate down pressure is very important. When the tool bit breaks through the obstruction or becomes bound, release the trigger and reposition the tool bit.

NOTE: Partially depressing the trigger allows the tool to run at slow speed. Slow-speed operation permits easier starting of the tool bit into the work surface.

5. To start, break an opening (hole) in the center of the surface. After making a hole, break portions of the material into the original opening. For best productivity, the breaking should be done around the original hole.

The bite or width of the broken material will vary with the strength and thickness of the base material and the amount of any reinforcement wire or rebar.

Harder material or more reinforcing wire or rebar will require taking smaller bites. To determine the most effective bite, start with 2 in. / 50 mm or smaller bites.

Bites can then be gradually increased until the broken piece becomes too large, requiring increased time to break off the piece.

Sticking of the tool bit occurs when too large a bite is being taken and the tool bit hammers into the material without the material fracturing. This causes the tool bit to become trapped in the surrounding material.

Cold Weather Operation

If the paving breaker is to be used during cold weather, preheat the hydraulic fluid at low engine speed. When using the normally recommended fluid, fluid temperature should be at or above 50° F/10° C (400 ssu/82 centistokes) before use.

Damage to the hydraulic system or breaker can result from use with fluid that is too viscous or thick.

Troubleshooting

This section describes how to find and resolve problems users may experience. If a situation occurs that is not covered, call your Stanley Customer Service representative for assistance.

WARNING

Inspecting the tool or installing parts with the hydraulic hoses connected can result in severe personal injury or equipment damage.

To prevent accidental startup, disconnect the hydraulic power before beginning any inspection or installation task.

If symptoms of poor performance develop, the following chart can be used as a guide to correct the problem.

When diagnosing faults in operation of the tool, always check that the hydraulic power source is supplying the correct hydraulic flow and pressure to the tool as listed in the table. Use a flowmeter known to be accurate. Check the flow with the hydraulic oil temperature at least 80° F/27° C.

Symptom	Possible Cause	Solution
Tool does not run.	Power unit not functioning.	Check power source for proper flow and pressure (7-9 gpm/ 26-34 lpm, 2000 psi/ 140 bar). (5-6 gpm/18-22 lpm 2000 psi/140 bar)
	Couplers or hoses blocked.	Remove restriction.
	Pressure and return line hoses reversed at ports.	Be sure hoses are connected to their proper ports.
	Mechanical failure of piston or automatic valve.	Have inspected and repaired by an authorized dealer.
Tool does not hit effectively.	Power unit not functioning.	Check power unit for proper flow and pressure (7-9 gpm/ 26-34 lpm, 2000 psi/ 140 bar). (5-6 gpm/18-22 lpm 2000 psi/140 bar)
	Couplers or hoses blocked.	Remove restriction.
	Low accumulator charge (pressure hose will pulse more than normal).	Have recharged by authorized dealer.
	Fluid too hot (above 140°F/ 60°C).	Provide cooler to maintain proper fluid temperature.
	Collar support not sliding freely in the foot bore (Easi-Ride™).	Remove, clean and replace as required.
Tool operates slow.	Low oil flow from power unit.	Check power source for proper flow.
	High backpressure. Exceeding 250 psi/17 bar	Check hydraulic system for excessive backpressure and correct as required.
	Orifice Plug Blocked.	Remove restriction.

Troubleshooting Continued:

Symptom	Possible Cause	Solution
Tool operates slow. (Cont.)	Fluid too hot (above 140°F/60°C) or too cold (below 60°F/16°C).	Check power source for proper fluid temperature. Bypass cooler to warm fluid up or provide cooler to maintain proper temperature.
	Relief valve set too low.	Adjust relief valve to 2100-2250 psi /145-155 bar.
	The collar support is not sliding freely in the foot bore..	Remove, clean, and replace collar support as required. Make sure hex bushing is in the proper location.
Tool gets hot.	Hot fluid going through tool.	Check power unit. Be sure flow rate is not too high causing part of the fluid to go through the relief valve. Provide cooler to maintain proper fluid temperature (140°F/60°C Max).
		Check relief valve setting..
		Eliminate flow control devices.
Fluid leakage on tool bit.	Lower piston seal failure.	Replace seal.
Fluid leakage around trigger.	Valve spool seal failure.	Replace seals.

General Maintenance Notes

1. If the breaker is repainted after servicing, do not allow paint to enter the **IN** and **OUT** ports or the bore of the foot assembly.
2. **If the handle grips need to be replaced:**
 - A. Remove old grips and clean the handles.
 - B. Wash the new grips with solvent and follow with soap and water wash.
 - C. With the grips and the handle clean and dry, simply push or drive the grips on. **DO NOT** lubricate the parts. The grips will not be secure on the handle if any grease or oil is used.

The most important maintenance practice is to keep the hydraulic fluid clean at all times. Contaminated hydraulic fluid causes rapid wear and/or failure of internal parts.

Charging the Accumulator

Accumulator Testing Procedure (See Figure 2)

To check or charge the accumulator the following equipment is required:

31254 Charge Kit: which includes the following.

- Accumulator Tester (Part Number 02835).
 - Charging Assembly (Part Number 15304) (15304 includes a liquid filled gauge w/snub valve, hose and fittings).
 - NITROGEN bottle with an 800 psi/55 bar minimum charge. **(Not included in 31254 kit)**
1. Remove the plug from the handle (BR47) or handle pivot (BR48).
 2. Holding the chuck end of Accumulator Tester (Part Number 02835) turn the gauge fully counterclockwise to ensure that the stem inside the chuck is completely retracted.
 3. Thread the tester onto the accumulator

charging valve. Do not advance the gauge-end into the chuck-end. Turn as a unit. Seat the chuck on the accumulator charging valve and hand tighten only.

4. Advance the valve stem of the tester by turning the gauge-end clockwise until a pressure is read on the gauge (charge pressure should be 500-700 psi/34-48 bar).
5. If pressure is OK unscrew the gauge-end from the chuck to retract the stem, then unscrew the entire tester assembly from the accumulator charging valve. If pressure is low, charge the accumulator as described in the following paragraph.
6. Install the plug.

Accumulator Charging

1. Perform steps 1 through 4 of the accumulator testing procedure above.
2. Connect the chuck of the charging assembly to the charging valve on the accumulator tester or, if preferred, remove the tester from the charging valve and connect the charging assembly chuck directly to the charging valve.
3. Adjust the snub valve to a charging pressure of 600 psi/42 bar. Note: While watching the pressure gauge, open snub valve slowly until it reaches the proper charge pressure (600-700 psi).

NOTE: It may be necessary to set the gauge at 650-700 psi/45-48 bar to overcome any pressure drop through the charging system.

4. When the accumulator is fully charged close the snub valve on the charging assembly hose and remove the charging assembly chuck from the accumulator tester or tool charging valve.
5. If the accumulator tester has been used, be sure to turn the gauge-end fully counterclockwise before removing the tester from the charging valve of the tool. Install the valve cap.

Maintenance

Charging The Accumulator (BR48)

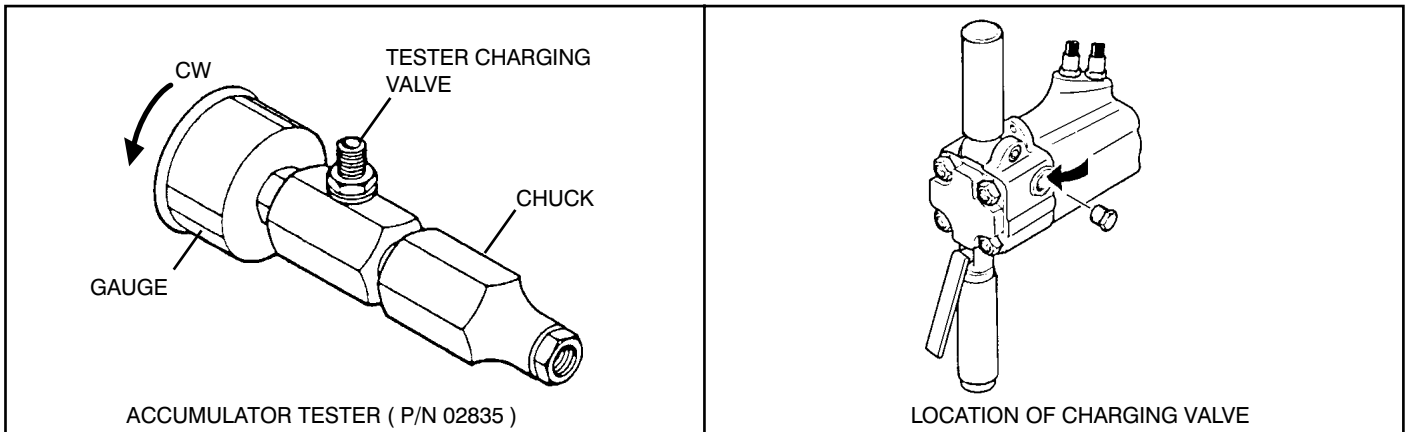
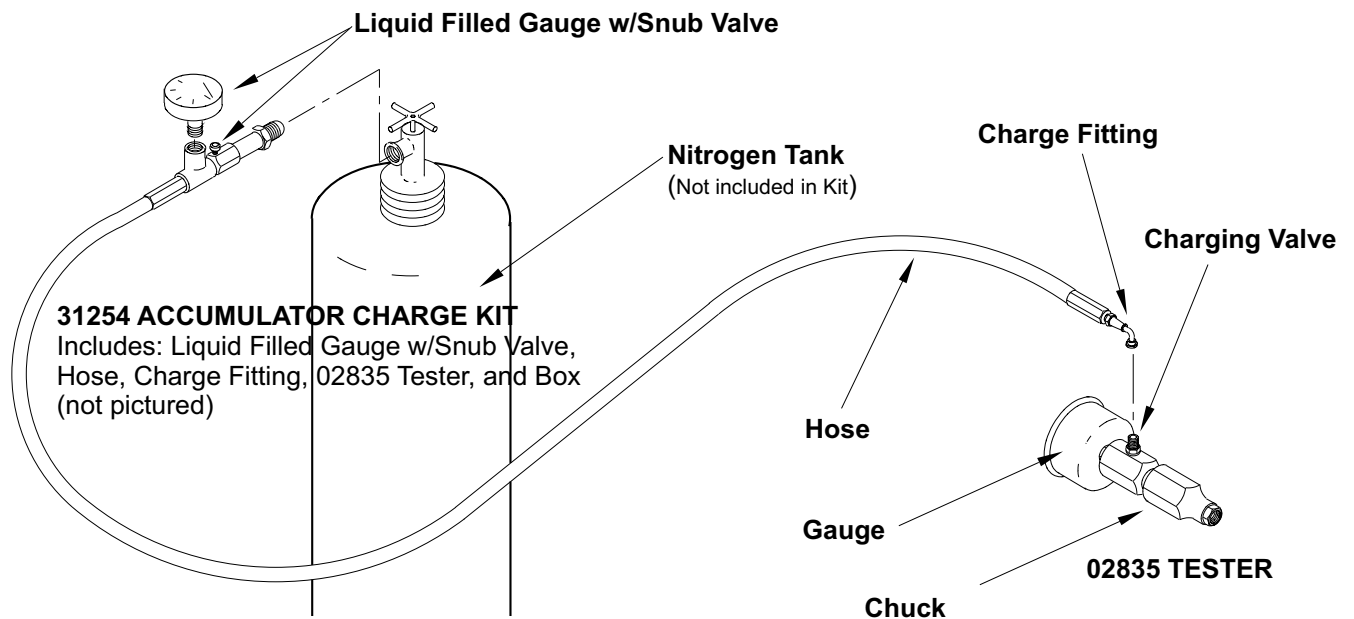

Figure 2



Charging The Accumulator (BR47)

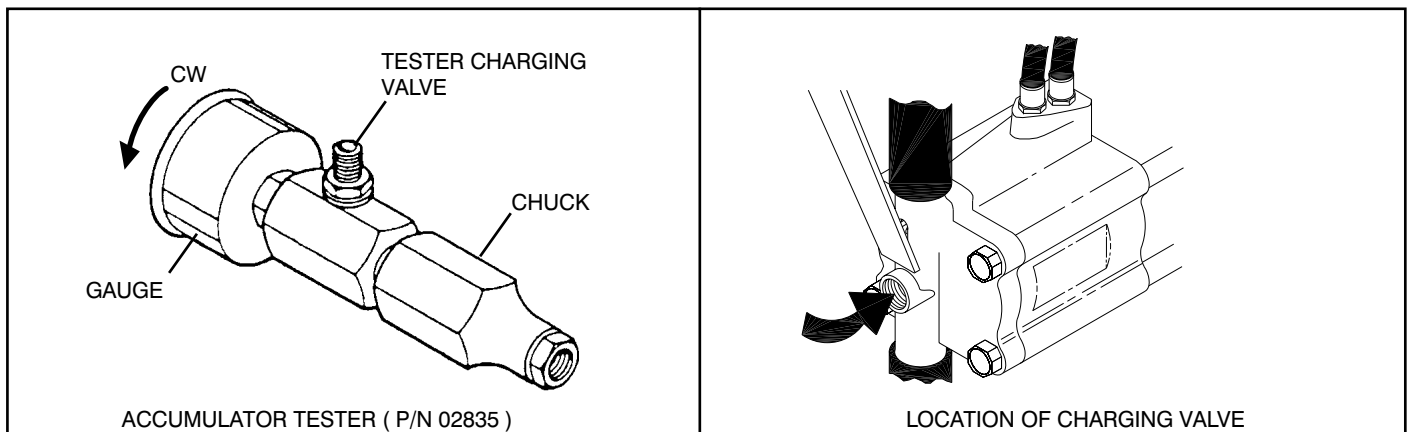

Figure 2

BR47 Parts List

Item No.	Part No.	QTY	Description
1	24069	1	Coupler Set
3	02900	2	Roll Pin
4	01652	2	Hose Assy.
5	11587	1	Orifice Plug (Used on BR4757201 Only)
6	01605	2	O-ring (Included With Item # 4)
7	04058	1	Spring
8	04077	1	Valve Spool
9	04057	1	Bushing
10	00293	1	O-ring, 11/16 x 7/8 x 3/32
11	01362	1	O-ring, 5/16 x 7/16 x 1/16
12	04056	1	Rod Wiper
13	07493	1	Plug
14	20499	1	Charge Valve
	09349	1	Valve Cap (Not Pictured)
15	02494	2	Handle Grip
16	11358	1	Handle
17	07492	2	Spirol Pin 1/4 x 1
18	07594	1	Trigger Lock
19	07593	1	Spring
20	00224	1	Retainer Ring
21	04374	4	LockNut 5/8-18
22	04371	1	Trigger
23	07479	1	Accumulator Diaphragm
24	34583	1	Piston
25	58603	1	Sound Power Level Sticker
26	28409	1	Composite Safety Label
27	04605	4	Push Pin
28	11588	1	Accumulator Valve Block
29	07485	1	Flow Sleeve
30	28322	1	CE Label
31	11207	1	Circuit "D" Label
32	11206	1	Circuit "C" Label
33	04381	2	Back-up Ring
34	04379	2	O-ring 2-9/16 x 2-3/4 x 3/32
35	09640	1	Porting Block
36	07480	1	Automatic Valve Body
37	04571	2	Push Pin
38	04382	1	Automatic Valve
39	28376	1	Stanley Label
40	28410	1	BR47 Model No. Label
41	04383	1	Flow Sleeve Tube
42	11230	1	Hex Bushing*
43	04984	1	Stop Nut*
44	11636	1	Breaker Foot*
45	02022	1	O-ring, 2-1/4 x 2-1/2 x 1/8 -228 R16*
46	04387	1	Rod Wiper
47	04780	1	Back-up Washer
48	04386	1	Cup Seal
49	04373	1	Side Rod
50	11208	4	Hex Shank Length Label
51	01837	1	Latch*
52	04985	1	Spring Washer*
53	04983	2	Foot Latch Bolt*
54	01269	1	Rubber Sleeve*
55	01744	2	Spring*
56	08411	1	Detent*
57	08158	1	Spring*
58	11234	1	Collar Support Assy*
59	07522	1	Retainer Ring*

NOTE:
Use Part Number and Description when ordering.

Seal Kit Part No. 13552		
Part No.	Description	Qty
04056	Rod Wiper	1
01362	O-ring	1
00293	O-ring	1
04381	Back-up ring	2
03127	Wiper ring	1
02022	O-ring	1
01604	O-ring	1
01605	O-Ring	2
04379	O-ring	2
34092	Cup Seal	1
09887	O-ring	1

* Part of Breaker Foot Assy.

Breaker Foot Assembly	
Part #	Model
48773	BR4757201

BR47 Parts Illustration

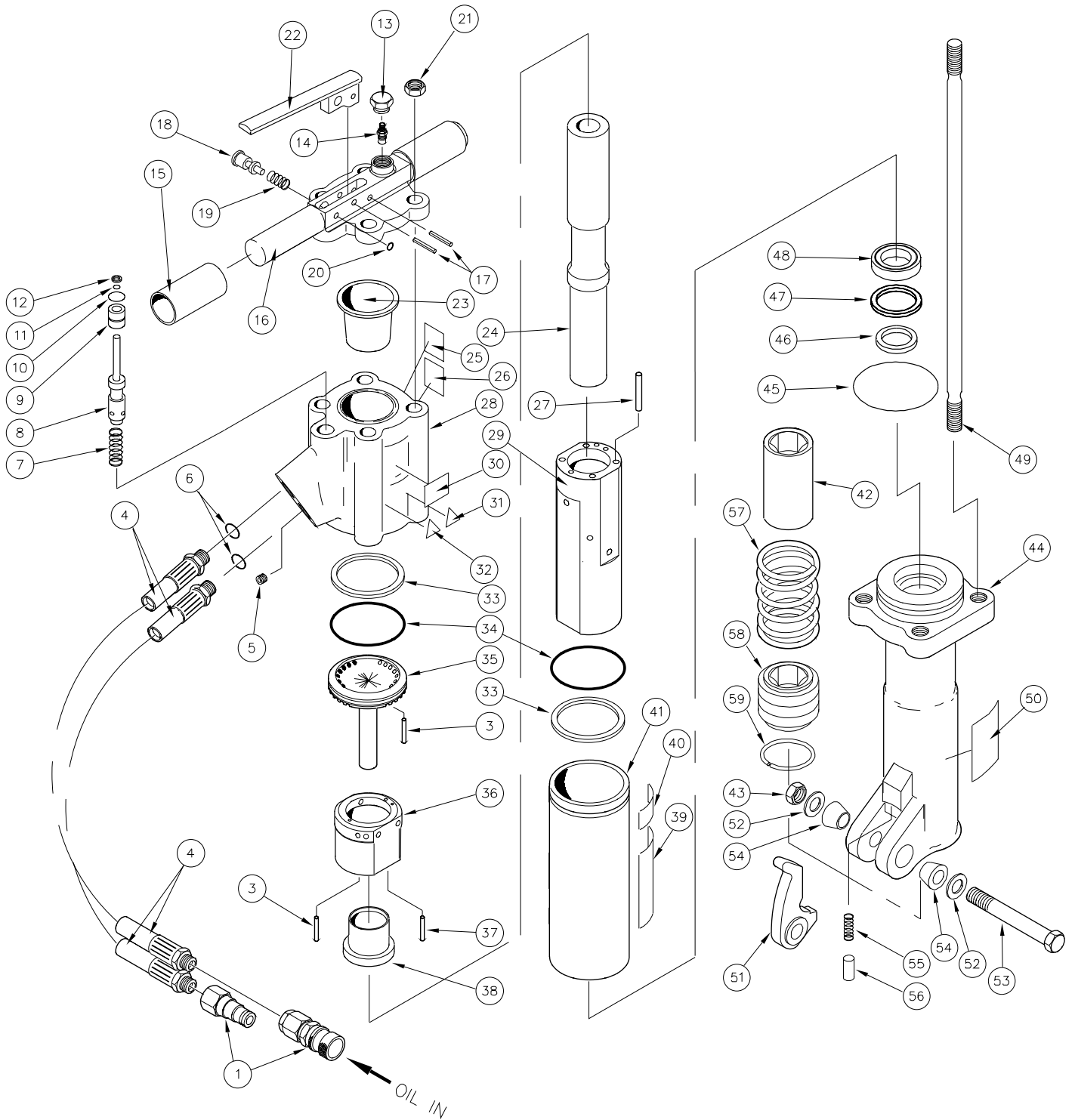

BR48 Parts List

Item No.	Part No.	QTY	Description
1	24069	1	Coupler Set
3	02900	2	Roll Pin
4	01652	2	Hose Assy.
5	11587	1	Orifice Plug (Used on BR4857801 Only)
6	01605	2	O-ring (Included With Item # 4)
7	04058	1	Spring
8	20515	1	Valve Spool
9	04057	1	Bushing
10	00293	1	O-ring, 11/16 x 7/8 x 3/32
11	01362	1	O-ring, 5/16 x 7/16 x 1/16
12	04056	1	Rod Wiper
13	20510	1	Plug
14	20499	1	Charge Valve
	09349	1	Valve Cap (Not Pictured)
15	02494	2	Handle Grip
16	28369	1	Handle (Guarded)
17	20500	2	Spirol Pin 1/4 x 1
18	20511	1	Lever
19	32297	1	Slotted Machine Screw
20	28494	1	Top Plate
21	04374	4	LockNut 5/8-18
22	20502	1	Trigger
23	16607	1	SAE O-ring Plug #10
24	24964	1	Spring
25	26599	1	Pin
26	31565	1	Trigger Handle
27	24948	1	Trigger Lock
28	31917	1	Trigger Pin
29	21089	1	Roll Pin 1/4 x 1-3/8
30	20540	2	Spring
31	20541	2	Spring
32	20505	1	Handle Pivot
33	20508	2	Pivot Screw
34	07479	1	Accumulator Diaphragm
35	19443	1	Piston, Model (BR4817801 ONLY)
	34583	1	Piston, Model (BR4857801 ONLY)
36	58603	1	Guaranteed Sound Power Level Sticker
37	28409	1	Composite Safety Label
38	04605	4	Push Pin
39	11588	1	Accumulator Valve Block
40	09611	1	Flow Sleeve, (Model BR4817801 ONLY)
	07485	1	Flow Sleeve, (Model BR4857801 ONLY)
41	28322	1	CE Label
42	11207	1	Circuit "D" Label
43	11206	1	Circuit "C" Label
44	04381	2	Back-up Ring
45	04379	2	O-ring 2-9/16 x 2-3/4 x 3/32
46	09640	1	Porting Block
47	07480	1	Automatic Valve Body
48	04571	2	Push Pin
49	04382	1	Automatic Valve
50	28376	1	Stanley Label
51	28411	1	BR48 Model No. Label
52	04383	1	Flow Sleeve Tube
53	11230	1	Hex Bushing*
54	04984	1	Stop Nut*
55	11636	1	Breaker Foot*
56	02022	1	O-ring, 2-1/4 x 2-1/2 x 1/8 -228 R16*
57	03127	1	Rod Wiper, (Model BR4817801 ONLY)*
	04387	1	Rod Wiper, (Model BR4857801 ONLY)*
58	09642	1	Back-up Washer, (Model BR4817801 ONLY)*
	07480	1	Back-up Washer, (Model BR4857801 ONLY)*
59	34092	1	Cup Seal, (Model BR4817801 ONLY)*
	04386	1	Cup Seal, (Model BR4857801 ONLY)*
60	20517	4	Side Rod
61	11208	1	Hex Shank Length Label
62	01837	1	Latch*
63	04985	2	Spring Washer*
64	04983	1	Foot Latch Bolt*
65	01269	2	Rubber Sleeve*
66	01744	1	Spring*
67	08411	1	Detent*
68	08158	1	Spring*
69	11234	1	Collar Support Assy*
70	07522	1	Retainer Ring*

NOTE:
Use Part Number and Description when ordering.

Seal Kit Part No. 04595 BR4857801		
Part No.	Description	Qty
04056	Rod Wiper	1
01362	O-ring	1
00293	O-ring	1
04381	Back-up ring	2
04387	Rod Wiper	1
02022	O-ring	1
01604	O-ring	1
01605	O-ring	2
04379	O-ring	2
04386	Cup Seal	1

Seal Kit Part No. 13552 BR4817801		
Part No.	Description	Qty
04056	Rod Wiper	1
01362	O-ring	1
00293	O-ring	1
04381	Back-up ring	2
03127	Wiper ring	1
02022	O-ring	1
01604	O-ring	1
01605	O-ring	2
04379	O-ring	2
34092	Cup Seal	1
09887	O-ring	1

* Part of Breaker Foot Assy.

Breaker Foot Assembly	
Part #	Model
48772	BR4817801
48773	BR4857801

BR48 Parts Illustration

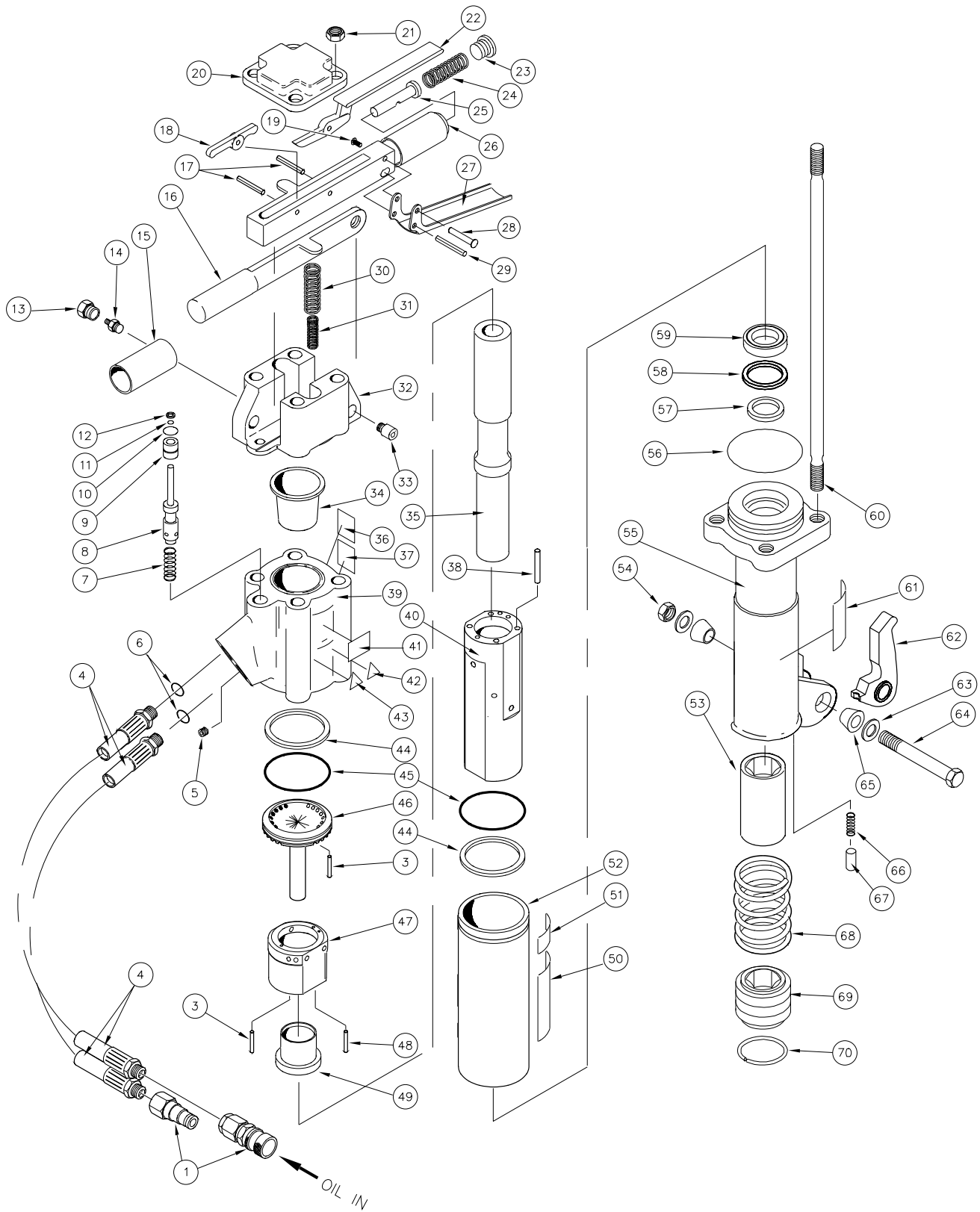

Accessories

NOTE:
Use **Part Number** and
Description when ordering.

Part	Description
	Test Equipment
02835	Accumulator Tester
31254	Accumulator Charge Kit Includes: 02835 Tester, 15304 Accumulator Charge Assy, and 372047 Box.
04182	Flow and Pressure Tester
15304	Accumulator Charge Assembly Includes: Liquid Filled Gauge w/Snub Valve, Hose, & Charge fitting

Service Tools

Part	Description
01120	Tamper Sleeve Tool
04337	O-ring Tool Kit
04910	Flow Sleeve Removal Tube
04919	Flow Sleeve Removal Tool
05640	Accumulator Cylinder Puller

Warranty

Stanley Hydraulic Tools (hereinafter called "Stanley"), subject to the exceptions contained below, warrants new hydraulic tools for a period of one year from the date of sale to the first retail purchaser, or for a period of 2 years from the shipping date from Stanley, whichever period expires first, to be free of defects in material and/or workmanship at the time of delivery, and will, at its option, repair or replace any tool or part of a tool, or new part, which is found upon examination by a Stanley authorized service outlet or by Stanley's factory in Milwaukie, Oregon to be DEFECTIVE IN MATERIAL AND/OR WORKMANSHIP.

EXCEPTIONS FROM WARRANTY

NEW PARTS: New parts which are obtained individually are warranted, subject to the exceptions herein, to be free of defects in material and/or workmanship at the time of delivery and for a period of 6 months after the date of first usage. Seals and diaphragms are warranted to be free of defects in material and/or workmanship at the time of delivery and for a period of 6 months after the date of first usage or 2 years after the date of delivery, whichever period expires first. Warranty for new parts is limited to replacement of defective parts only. Labor is not covered.

FREIGHT COSTS: Freight costs to return parts to Stanley, if requested by Stanley for the purpose of evaluating a warranty claim for warranty credit, are covered under this policy if the claimed part or parts are approved for warranty credit. Freight costs for any part or parts which are not approved for warranty credit will be the responsibility of the individual.

SEALS & DIAPHRAGMS: Seals and diaphragms installed in new tools are warranted to be free of defects in material and/or workmanship for a period of 6 months after the date of first usage, or for a period of 2 years from the shipping date from Stanley, whichever period expires first.

CUTTING ACCESSORIES: Cutting accessories such as breaker tool bits are warranted to be free of defects in material and or workmanship at the time of delivery only.

ITEMS PRODUCED BY OTHER MANUFACTURERS: Components which are not manufactured by Stanley and are warranted by their respective manufacturers.

- a. Costs incurred to remove a Stanley manufactured component in order to service an item manufactured by other manufacturers.

ALTERATIONS & MODIFICATIONS: Alterations or modifications to any tool or part. All obligations under this warranty shall be terminated if the new tool or part is altered or modified in any way.

NORMAL WEAR: Any failure or performance deficiency attributable to normal wear and tear such as tool bushings, retaining pins, wear plates, bumpers, retaining rings and plugs, rubber bushings, recoil springs, etc.

INCIDENTAL/CONSEQUENTIAL DAMAGES: To the fullest extent permitted by applicable law, in no event will STANLEY be liable for any incidental, consequential or special damages and/or expenses.

FREIGHT DAMAGE: Damage caused by improper storage or freight handling.

LOSS TIME: Loss of operating time to the user while the tool(s) is out of service.

IMPROPER OPERATION: Any failure or performance deficiency attributable to a failure to follow the guidelines and/or procedures as outlined in the tool's operation and maintenance manual.

MAINTENANCE: Any failure or performance deficiency attributable to not maintaining the tool(s) in good operating condition as outlined in the Operation and Maintenance Manual.

HYDRAULIC PRESSURE & FLOW, HEAT, TYPE OF FLUID: Any failure or performance deficiency attributable to excess hydraulic pressure, excess hydraulic back-pressure, excess hydraulic flow, excessive heat, or incorrect hydraulic fluid.

REPAIRS OR ALTERATIONS: Any failure or performance deficiency attributable to repairs by anyone which in Stanley's sole judgement caused or contributed to the failure or deficiency.

MIS-APPLICATION: Any failure or performance deficiency attributable to mis-application. "Mis-application" is defined as usage of products for which they were not originally intended or usage of products in such a manner which exposes them to abuse or accident, without first obtaining the written consent of Stanley. PERMISSION TO APPLY ANY PRODUCT FOR WHICH IT WAS NOT ORIGINALLY INTENDED CAN ONLY BE OBTAINED FROM STANLEY ENGINEERING.

WARRANTY REGISTRATION: STANLEY ASSUMES NO LIABILITY FOR WARRANTY CLAIMS SUBMITTED FOR WHICH NO TOOL REGISTRATION IS ON RECORD. In the event a warranty claim is submitted and no tool registration is on record, no warranty credit will be issued without first receiving documentation which proves the sale of the tool or the tools' first date of usage. The term "DOCUMENTATION" as used in this paragraph is defined as a bill of sale, or letter of intent from the first retail customer. A WARRANTY REGISTRATION FORM THAT IS NOT ALSO ON RECORD WITH STANLEY WILL NOT BE ACCEPTED AS "DOCUMENTATION".

NO ADDITIONAL WARRANTIES OR REPRESENTATIONS

This limited warranty and the obligation of Stanley thereunder is in lieu of all other warranties, expressed or implied including merchantability or

For additional Sales & Service information, contact:



Stanley Hydraulic Tools
Division of the Stanley Works
3810 SE Naef Road
Milwaukie, OR 97267 USA

Tel: (503) 659-5660
Fax: (503) 652-1780