



Model 5091A & 5091AL

1" S.D. Sq. Drive

"D" Handle Impact Tool

Form # Z454A
Date 2-02/B



IMPORTANT

Read these instructions carefully before installing, operating, servicing or repairing this tool. Keep these instructions in a safe accessible place.

SAFETY MESSAGES		WARNING	Operator Instructions
Personal Safety Equipment			Includes: Safety Rules Foreseen Use Work Stations Putting into Service Operating Dismantling and Assembly.
Use – Safety Glasses	YES	Always Read Instructions Before Using Power Tools	
Use – Safety Gloves		Always Wear Safety Goggles	
Use – Safety Boots		Wear Hearing Protection	
Use – Breathing Masks		Avoid Prolonged Exposure To Vibration	
Use – Ear Protectors	YES		

Safety rules when using a 5091A or 5091AL Impact Tool

- Use only impact sockets and extensions, universal joints, etc., rated as being suitable for use with impact tools.
- Prolonged exposure to vibration may cause injury.
- Read all instructions before using this tool. All operators must be fully trained in its use and aware of these safety rules.
- Do not exceed the maximum working air pressure.
- Use personal protection equipment as recommended.
- Some dust created by power sanding, sawing, grinding, drilling, and other construction activities contains chemicals known to cause cancer, birth defects and other reproductive harm.
- Use compressed air only at the recommended conditions.
- If the tool appears to malfunction, remove from use immediately and arrange for service and repair. If it is not practical to remove tool from service, then shut off the air supply to the tool and write or have written a warning note and attach it to the tool.
- If tool is to be used with a balancer or other suspension device, ensure that the tool is firmly attached to the suspension/support device.
- When operating the tool, always keep the body and particularly the hands away from the working attachment fixed to the tool.
- The tool is not electrically insulated. Never use the tool if there is any chance of coming into contact with live electricity.
- Always when using the tool, adopt a firm footing and/or position and grip the tool sufficiently only to overcome any reaction forces that may result from the tool doing work. Do not overgrip.
- Use only correct spare parts for maintenance and repair. Do not improvise or make temporary repairs. Major servicing and repairs should only be carried out by persons trained to do so.
- Do not lock, tape, wire, etc. the 'On/Off' valve in 'On' position. The throttle trigger/lever, etc. must always be free to return to the 'Off' position when released.
- Always shut off the air supply to the tool and press the 'On/Off' valve to exhaust the air from the feed hose before fitting, removing or adjusting the working attachment fitted to the tool.
- Before using the tool, make sure that a shut off device has been fitted to the supply line and the position is known and easily accessible so that the air supply to the tool can be shut off in an emergency.
- Check hose and fittings regularly for wear.
- Take care against entanglement of the moving parts of the tool with clothing, hair, ties, cleaning rags, rings, jewelry, watches, bracelets, etc. This could cause the body or parts of the body to be drawn towards and in contact with the moving parts of the tool and could be very dangerous.
- It is expected that users will adopt safe working practices and observe all local, regional or country legal requirements when installing, using or maintaining the tool.
- Take care that the exhaust air does not point towards any other person or material or substance that could be contaminated by oil droplets. When first lubricating a tool or if the tool exhaust has a high oil content, do not allow the exhaust air to come near very hot surfaces or flames.
- Never lay the tool down until the working attachment has stopped moving.
- When the tool is not in use, shut off the air supply and press throttle trigger/lever to drain the supply line. If the tool is not to be used for a period of time, first lubricate, disconnect from air supply and store in a dry average room temperature environment.
- If the tool is passed from one user to a new or inexperienced user, make sure these instructions are available to be passed with the tool.
- Do not remove any manufacturer fitted safety devices where fitted, i.e., wheel guards, safety trigger, speed governors, etc.
- Wherever possible, secure workpiece with clamps, a vise, etc. to make it rigid so it does not move during the work operation. Keep good balance at all times. Do not stretch or overreach.
- Try to match the tool to the work operation. Do not use a tool that is too light or heavy for the work operation. If in doubt, seek advice.
- In general terms, this tool is not suitable for underwater use or use in explosive environments — seek advice from manufacturer.
- Try to make sure that the work area is clear to enable the work task to be performed safely. If practical and possible, try to clear unnecessary obstructions before starting work.
- Always use air hose and couplings with minimum working pressure ratings at least 1 1/2 times the maximum working pressure rating of the tool.

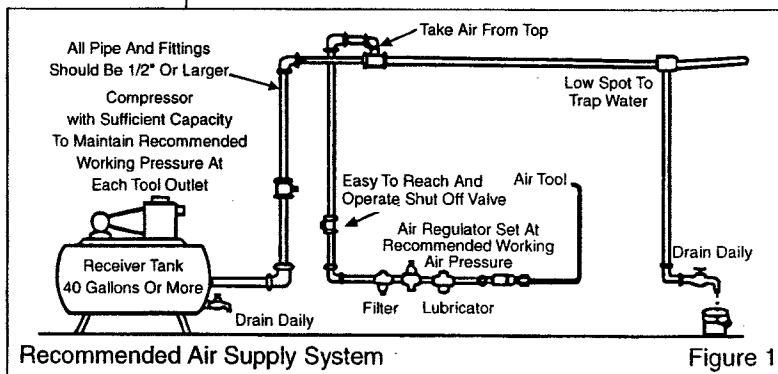

Foreseen Use Of The Tool – 5091A & 5091AL

The impact tool is designed for the tightening and loosening of threaded fastener within the range as specified by the manufacturer. It should only be used in conjunction with suitable impact type 1" square female drive nut running sockets. Only use sockets which are of the impact type.

It is allowed to use suitable extension bars, universal joints and socket adaptors between the square output drive of the impact tool and the female square drive of the socket.

Do not use the tool for any other purpose than that specified without consulting the manufacturer or the manufacturer's authorized supplier. To do so may be dangerous.

Never use an impact tool as a hammer to dislodge or straighten cross threaded fasteners. Never attempt to modify the tool for other uses and never modify the tool for even its recommended use as a nutrunner.

Work Stations

The tool should only be used as a handheld, hand operated tool. It is always recommended that the tool is used when standing on a solid floor. It can be used in other positions, but before any such use, the operator must be in a secure position having a firm grip and footing and be aware that when loosening fasteners the tool can move quite quickly away from the fastener being undone. An allowance must always be made for this rearward movement so as to avoid the possibility of hand/arm/body entrapment.

Putting Into Service

Air Supply

Use a clean lubricated air supply that will give a measured air pressure at the tool of 90 PSIG (6.2 bar) when the tool is running with the trigger/lever fully depressed. Use recommended hose size and length. It is recommended that the tool is connected to the air supply as shown in figure 1. Do not connect the tool to the air line system without incorporating an easy to reach and operate air shut off valve. The air supply should be lubricated. It is strongly recommended that an air filter, regulator, lubricator (FRL) is used as shown in Figure 1 as this will supply clean, lubricated air at the correct pressure to the tool. Details of such equipment can be obtained from your supplier. If such equipment is not used, then the tool should be lubricated by shutting off the air supply to the tool, depressurizing the line by pressing the trigger on the tool. Disconnect the air line and pour into the hose adaptor a teaspoonful (5ml) of a suitable pneumatic motor lubricating oil preferably incorporating a rust inhibitor. Reconnect tool to air supply and run tool slowly for a few seconds to allow air to circulate the oil. If tool is used frequently, lubricate on daily basis and if tool starts to slow or lose power. When lubricating, also ensure that the air strainer in hose adaptor is clean.

It is recommended that joint tightness of the threaded fastener assembly be checked with a torque wrench. It is recommended that the air pressure at the tool while the tool is running is 90 PSI/6.2 bar.

Operating

The output of the impact tool in prime working condition is governed by mainly three factors:

- a) the input air pressure;
- b) the time the impact tool is operated on the joint. Normal time for joints of average tension requirement 3 to 5 seconds;
- c) the setting of the air regulator for a given joint at a given pressure operated for a given time.

The air regulator (13) can be used to regulate the output of the impact tool if no other means of control is available. It is strongly recommended that an external pressure regulator, ideally as part of a filter/regulator/lubricator (FRL), is used to control air inlet pressure so that the pressure can be set to help control the tension required to be applied to the threaded fastener joint.

There is no consistent, reliable torque adjustment on an impact tool of this type. However, the air regulator can be used to adjust torque to the approximate tightness of a known threaded joint. To set the tool to the desired torque, select a nut or screw of known tightness of the same size, thread pitch and thread condition as those on the job. Turn air regulator to low position, apply tool to nut and gradually increase power (turn regulator to admit more air) until nut moves slightly in the direction it was originally set. The tool is now set to duplicate that tightness, note regulator setting for future use. When tightening nuts not requiring critical torque values, run nut up flush and then tighten an additional one-quarter to one-half turn (slight additional turning is necessary if gaskets are being clamped). For additional power needed on disassembly work, turn regulator to its fully open position. This impact tool is rated a 1" bolt size.

Rating must be downgraded for spring U bolts, tie bolts, long cap screws, double depth nuts, badly rusted conditions and spring fasteners as they absorb much of the impact power. When possible, clamp or wedge the bolt to prevent springback.

Soak rusted nuts in penetrating oil and break rust seal before removing with impact tool. If nut does not start to move in three to five seconds use a larger size impact tool. Do not use impact tool beyond rated capacity as this will drastically reduce tool life.

NOTE: Actual torque on a fastener is directly related to joint hardness, tool speed, condition of socket and the time the tool is allowed to impact.

Use the simplest possible tool-to-socket hook up. Every connection absorbs energy and reduces power.

The forward/reverse lever located on the lower left side of the handle has an "F" on one end and an "R" on the other. For forward (clockwise) anvil rotation, rotate the lever fully counter-clockwise to align the "F" with the arrow stamped on the handle. For reverse (counter-clockwise) anvil rotation, rotate the lever fully clockwise and align the "R" with the arrow. Make sure that the "F" or "R" are fully aligned with the arrow before depressing the trigger.

The air regulator located at the bottom of the handle has four positions. Position "O" indicates no impact blows. "1" indicates the lowest and "4" the highest power output. The anvils of the tools have holes through the square drive for use with pin-and-ring socket retainers. The pin, made of steel or reinforced plastic, is inserted through the hole in the socket and square drive and held in place by the ring. An air strainer is fitted in the hose adaptor (9). Check periodically for blockage, particularly if the tool slows or loses power. Remove hose adaptor to clean strainer. The tool is supplied with an auxiliary handle which can be secured around steel housing (47). Set in desired position and tighten washer and screw (50).

For best results:

- 1) Always use the correct size impact type socket.
- 2) Use extra deep sockets in place of extension bars where possible.
- 3) Do not use oversized, worn or cracked sockets.
- 4) Hold the tool so the socket fits squarely on the fastener. Hold the tool firmly, but not too tightly, pressing slightly forward.

Dismantling & Assembly Instructions

The models 5091A and 5091AL are identical except that the anvil (41) is 5 1/2" longer on model 5091AL than anvil (40) on model 5091A. Disconnect tool from air supply.

First remove the side handle (49) by removing capscrews (50) and remove handle band (52) and handle (49). Take out plug (31) and drain the oil from the front end into a suitable container. Grip the throttle handle housing (1) in a vise fitted with soft jaws and remove 4 front end capscrews (19) and pull off housing (47) complete with O-ring (46). Oil seal (48) may be hooked out of and anvil bushing (45) pressed out of housing (47). Pull off hammer assembly and pull out anvil (40) or (41) from hammer cage (34) and separate cam release spring (39), pilot shaft (36), cam (38), 2 hammer pins (37), and ball (35). Take off anvil spacer (42) and socket ring (44) and O-ring (43) from anvil (40) or (41). Take out 2 set screws (33) and remove exhaust deflector (32). Take out 4 capscrews (19) and pull off motor housing (30) complete with motor assembly. Take off gasket (20) from handle housing (1).

Holding motor housing (30), tap the splined end of rotor (24) to remove the complete motor assembly from housing (30). Take out guide pin (2) and pull off rear plate (22) assembly and front plate (26) assembly from rotor (24) thus releasing cylinder (25). Note the orientation of cylinder (25) to plates (22) and (26) for reassembly. Take out 6 rotor blades (23) from rotor (24). Tap out bearing (21) from rear plate (22) and tap out bearing (29) and remove oil seal (28) and O-ring (27) from front plate (26). Drive out 2 spring pins (4) and take off outside trigger (3) or inside trigger (53) as fitted. Drive out spring pin (14) and pull out air regulator (13) with O-ring (12) being careful not to lose lock spring (10) and ball (11). Unscrew hose adaptor (9) with O-ring (54) and take out spring (8), valve pin (6) with O-rings (5) and valve



5091A 1" SD Inside/Outside Lever Impact Tool
5091AL 5091A with 5 1/2" Extended Anvil

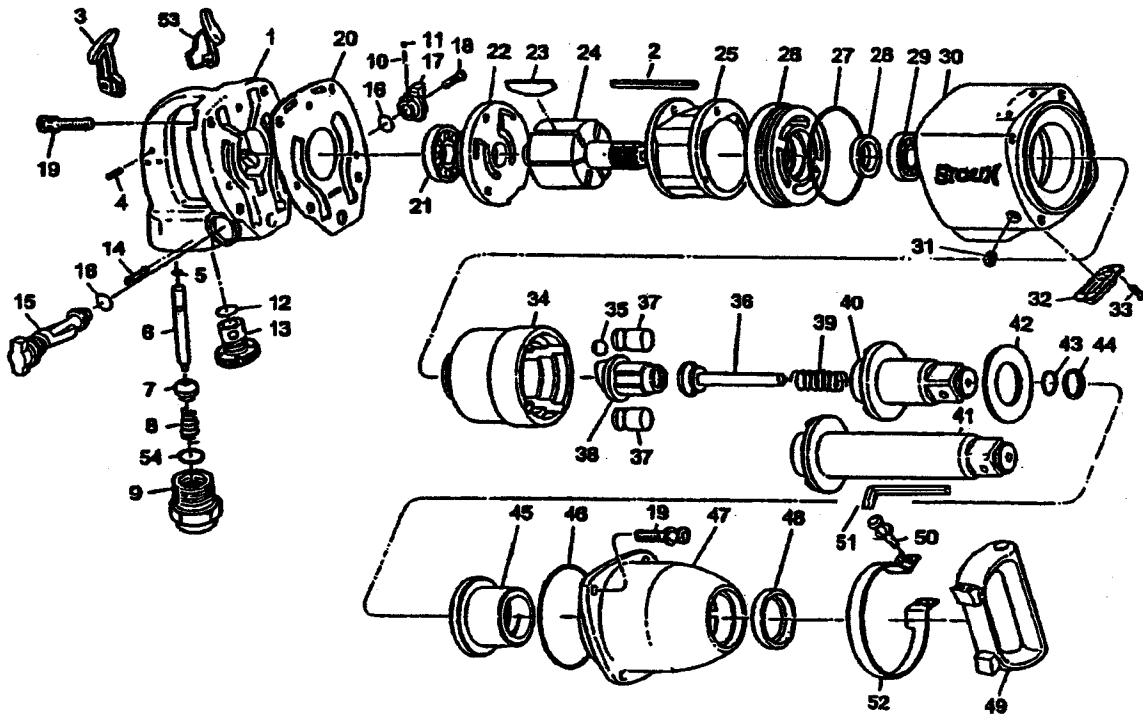

Ref. No.	Part No.	Description
1	505639	Throttle Handle Housing
2	505253	Guide Pin
3	505254	Throttle Trigger (outside)
4	505294	Spring Pin (2)*
5	505197	O-Ring
6	505642	Valve Pin
7	505255	Valve Ball
8	505256	Throttle Spring
9	505257	Hose Adaptor
10	505900	Spring (2)*
11	505901	Steel Ball (2)*
12	505258	O-Ring
13	505259	Air Regulator
14	66602	Spring Pin
15	505260	Reversing Valve
16	505261	O-Ring (2)*
17	505262	Reverse Valve Lever
18	505263	Self Tapping Screw
19	505264	Cap Screw with Washer (8)*
20	505265	Gasket
21	505266	Ball Bearing
22	505267	Rear Plate
23	505268	Rotor Blade (6)
24	505269	Rotor
25	505270	Cylinder
26	505643	Front Plate
27	505644	O-Ring
28	505272	Oil Seal
29	505273	Ball Bearing
30	505648	Motor Housing

Ref. No.	Part No.	Description
31	66604	Oil Plug
32	505276	Exhaust Deflector
33	67227	Setting Screw (2)*
34	505277	Hammer Cage
35	505278	Cam Ball
36	505279	Pilot Shaft
37	505280	Hammer Pin (2)*
38	505281	Hammer Cam
39	505282	Cam Release Spring
40	505283	Assy Anvil (5091A) (Inc. Figs 43 & 44)
41	505284	Assy Anvil (5091AL) (Inc. Figs 43 & 44)
42	505285	Anvil Spacer
43	505201	O-Ring
44	505245	Retainer Ring
45	505286	Anvil Bushing
46	505287	O-Ring
47	505288	Steel Housing
48	505289	Oil Seal
49	505649	Dead Handle with Rubber
50	505633	Cap Screw with Washer (4)*
51	505632	Hex Wrench
52	505291	Handle Band
53	505292	Throttle Trigger (inside)
54	505293	O-Ring
	Not Shown	
	505001	Label Warning
	505898	Nameplate (5091A)
	505897	Nameplate (5091AL)
	67255	Nameplate Screw (2)*

*Order Quantity as Needed



ball (7) may be removed from valve pin (6). Unscrew self tapping screw (18) and reversing valve (15), 2 O-rings (16) and reverse valve lever (17) may be taken out of handle housing (1) being careful not to lose lock spring (10) and ball (11).

Reassembly

Clean all components and examine for wear, cracks, etc. before reassembling. Look in particular for wear and cuts on oil seals and O-rings, wear on rotor blades (23), and wear and cracks on hammer cage (34), 2 hammer pins (37), Hammer cam (38) and anvils (40) and (41) particularly around the area of the square drive. Make sure that socket ring (44) and O-ring (43) on anvils (40) and (41) will still adequately retain a socket. Make sure that the faces of end plates (22) and (26) that abut cylinder (25) are flat and free from surface markings and burrs. If necessary, lap faces with a very fine grade of abrasive paper. Use only manufacturer or authorized distributor replacement parts. Coat all parts with a suitable pneumatic motor lubricating oil and assemble in the reverse order. NOTE: when reassembling the motor assembly into the motor housing (30), first build motor assembly and set aside. Grip the handle housing (1) in a vise with gasket face uppermost. Lay on gasket (20) and motor assembly, making sure that guide pin (2) locates in the matching hole through the gasket and into the end face of handle housing (1). Slide motor housing (30) over motor assembly pushing the motor housing up to the gasket (20) and secure with 4 screws (19).

On completing assembly, ensure that all parts are locked tight, the anvil will rotate, and the trigger reverse valve and air regulator mechanism all operate freely. Remove oil plug (31) and pour into the front end 1.35 fl. oz. (40ml) of a standard SAE20W oil and replace and tighten oil plug (31). Do not overfill as this will result in a reduction in power of the tool. Pour into the hose adaptor, with the trigger depressed, 10 ml of a pneumatic tool lubricating oil (one preferably containing a rust inhibitor). Connect tool to a suitable air supply and run the tool slowly for 2 to 3 seconds to allow the oil to circulate. Reset for required operation – see Operating.

Operation Specification		
	5091A	5091AL
Avg. Air Consumption	9.0 cfm (65 scfm)	
Torque Range	500-1200 ft.lb. (678-1627 Nm)	500-1150 ft.lb. (678-1559 Nm)
Max. Torque	1500 ft. lbs. (2034 Nm)	
Air Inlet Thread	1/2-14NPT	
Overall Length	14.43 ins. (366mm)	19.32 ins. (490mm)
	at 90 PSIG/6.2 bar	

Manufacturer/Supplier Sioux Tools, Inc. 117 Levi Drive Murphy, NC 28906 U.S.A. Tel No. 828-835-9765 Fax No. 828-835-9685		Product Type 1" Sq. Drive "D" Handle Impact Tool	RPM 4,000 Cycles Per Min.	
		Model No/Nos 5091A Std. Anvil 5091AL 5-1/2" Ext. Anvil	Serial No.	
Product Net Weight (5091A) (5091AL) 16.7 18.5 lbs 7.6 8.4 Kg	Recommended Use Of Balancer Or Support YES	Recommended Hose Bore Size – Minimum 1/2 Ins 10 M/M	Recommended Max. Hose Length 30 Ft 10 M	
Air Pressure Recommended Working 6.2 bar 90 PSI Maximum 6.2 bar 90 PSI		Noise Level: Sound Pressure Level 97.0 dB(A) Sound Power Level 108.0 dB(A) Test Method: Tested in accordance with Pneurop test code PN8NTC1 and ISO Standard 3744		
SAFETY MESSAGES Personal Safety Equipment Use – Safety Glasses YES Use – Safety Gloves Use – Safety Boots Use – Breathing Masks Use – Ear Protectors YES	 WARNING Always Read Instructions Before Using Power Tools Always Wear Safety Goggles Wear Hearing Protection Avoid Prolonged Exposure To Vibration	Vibration Level 5091A – 5.2 Meters / Sec ² 5091AL – 6.7 Meters / Sec ² Test Method: Tested in accordance with ISO standards 8662 Parts 1 & 7		



Declaration of Conformity
Sioux Tools Inc.
117 Levi Drive, Murphy, NC 28906, U.S.A.
declare under our sole responsibility that the product

Model 5091A & 5091AL 1" Impact Tools, Serial Number
to which this declaration relates is in conformity with the following standard(s) or other normative document(s)
EN792 (Draft), EN292 Parts 1 & 2, ISO 8662 Parts 1 & 7, Pneurop PN8NTC1
following the provisions of **89/392/EEC as amended by 91/368/EEC & 93/44/EEC Directives**

Gerald E. Seebeck (President)

Name and signature or equivalent marking of authorized person