



Model 5268

Angle Disc Grinder

4 1/2 Dia. Disc

Form # Z440
Date 2-02/A



IMPORTANT

Read these instructions carefully before installing, operating, servicing or repairing this tool. Keep these instructions in a safe accessible place.

SAFETY MESSAGES		WARNING	Operator Instructions
Personal Safety Equipment			Includes: Safety Rules Foreseen Use Work Stations Putting Into Service Operating Dismantling and Assembly.
Use – Safety Glasses	YES	Always Read Instructions Before Using Power Tools	
Use – Safety Gloves	YES	Always Wear Safety Goggles	
Use – Safety Boots		Wear Hearing Protection	
Use – Breathing Masks	YES	Avoid Prolonged Exposure To Vibration	
Use – Ear Protectors	YES		

Safety rules when using a 5268 Disc Grinder

- Wear safety goggles of the impact type.
- Never use the tool if the disc guard is not fitted.
- Use accessories rated at least 12,000 RPM.
- Prolonged exposure to vibration may cause injury.
- Read all instructions before using this tool. All operators must be fully trained in its use and aware of these safety rules.
- Do not exceed the maximum working air pressure.
- Use personal protection equipment as recommended.
- Some dust created by power sanding, sawing, grinding, drilling, and other construction activities contains chemicals known to cause cancer, birth defects and other reproductive harm.
- Use compressed air only at the recommended conditions.
- If the tool appears to malfunction, remove from use immediately and arrange for service and repair. If it is not practical to remove tool from service, then shut off the air supply to the tool and write or have written a warning note and attach it to the tool.
- If tool is to be used with a balancer or other suspension device, ensure that the tool is firmly attached to the suspension/support device.
- When operating the tool, always keep the body and particularly the hands away from the working attachment fixed to the tool.
- The tool is not electrically insulated. Never use the tool if there is any chance of coming into contact with live electricity.
- Always when using the tool, adopt a firm footing and/or position and grip the tool sufficiently only to overcome any reaction forces that may result from the tool doing work. Do not overgrip.
- Use only correct spare parts for maintenance and repair. Do not improvise or make temporary repairs. Major servicing and repairs should only be carried out by persons trained to do so.
- Do not lock, tape, wire, etc. the 'On/Off' valve in 'On' position. The throttle trigger/lever, etc. must always be free to return to the 'Off' position when released.
- Always shut off the air supply to the tool and press the 'On/Off' valve to exhaust the air from the feed hose before fitting, removing or adjusting the working attachment fitted to the tool.
- Before using the tool, make sure that a shut off device has been fitted to the supply line and the position is known and easily accessible so that the air supply to the tool can be shut off in an emergency.
- Check hose and fittings regularly for wear.
- Take care against entanglement of the moving parts of the tool with clothing, hair, ties, cleaning rags, rings, jewelry, watches, bracelets, etc. This could cause the body or parts of the body to be drawn towards and in contact with the moving parts of the tool and could be very dangerous.
- It is expected that users will adopt safe working practices and observe all local, regional or country legal requirements when installing, using or maintaining the tool.
- Take care that the exhaust air does not point towards any other person or material or substance that could be contaminated by oil droplets. When first lubricating a tool or if the tool exhaust has a high oil content, do not allow the exhaust air to come near very hot surfaces or flames.
- Never lay the tool down until the working attachment has stopped moving.
- When the tool is not in use, shut off the air supply and press throttle trigger/lever to drain the supply line. If the tool is not to be used for a period of time, first lubricate, disconnect from air supply and store in a dry average room temperature environment.
- If the tool is passed from one user to a new or inexperienced user, make sure these instructions are available to be passed with the tool.
- Do not remove any manufacturer fitted safety devices where fitted, i.e., wheel guards, safety trigger, speed governors, etc.
- Wherever possible, secure workpiece with clamps, a vise, etc. to make it rigid so it does not move during the work operation. Keep good balance at all times. Do not stretch or overreach.
- Try to match the tool to the work operation. Do not use a tool that is too light or heavy for the work operation. If in doubt, seek advice.
- In general terms, this tool is not suitable for underwater use or use in explosive environments — seek advice from manufacturer.
- Try to make sure that the work area is clear to enable the work task to be performed safely. If practical and possible, try to clear unnecessary obstructions before starting work.
- Always use air hose and couplings with minimum working pressure ratings at least 1 1/2 times the maximum working pressure rating of the tool.

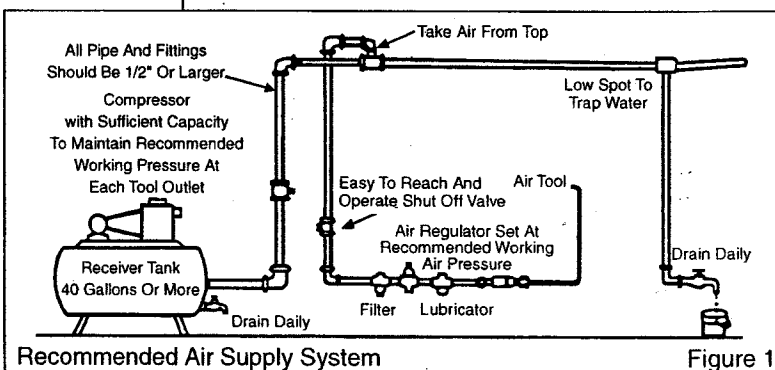

Figure 1

Foreseen Use Of The Tool – 5268

This right angle grinder is designed to be used with reinforced resin bonded depressed center grinding wheels that have a permitted rotational speed in excess of 12,000 RPM.

The tool is designed to be used for light grinding and dressing of welds, etc., but not for cutting off. The grinder must never be used if a wheel guard (disc guard) item (3) is not fitted.

Work Stations

The tool should only be used as a handheld, hand operated tool. It is always recommended that the tool is used when standing on a solid floor. It can be used in other positions, but before any such use, the operator must be in a secure position having a firm grip and footing and be aware of the extra safety precautions that must be observed when using grinding machines.

Putting Into Service

Air Supply

Use a clean lubricated air supply that will give a measured air pressure at the tool of 90 PSIG (6.2 bar) when the tool is running with the trigger/lever fully depressed. Use recommended hose size and length. It is recommended that the tool is connected to the air supply as shown in figure 1. Do not connect the tool to the air line system without incorporating an easy to reach and operate air shut off valve. The air supply should be lubricated. It is strongly recommended that an air filter, regulator, lubricator (FRL) is used as shown in Figure 1 as this will supply clean, lubricated air at the correct pressure to the tool. Details of such equipment can be obtained from your supplier. If such equipment is not used, then the tool should be lubricated by shutting off the air supply to the tool, depressurizing the line by pressing the trigger on the tool. Disconnect the air line and pour into the hose adaptor a teaspoonful (5ml) of a suitable pneumatic motor lubricating oil preferably incorporating a rust inhibitor. Reconnect tool to air supply and run tool slowly for a few seconds to allow air to circulate the oil. If tool is used frequently, lubricate on daily basis and if tool starts to slow or lose power. It is recommended that the air pressure at the tool while the tool is running is 90 PSI/6.2 bar.

Operating

With the grinder correctly connected to the air supply, check the speed of the grinder with an inlet pressure of 90 PSI/6.2 bar measured at the tool inlet. Check with a calibrated tachometer. Check that the guard is in position and securely fixed. Check that the grinding wheel is of correct dimensions, is not cracked or chipped and has a permitted speed rating higher than the maximum permissible running speed of the grinder, which is 12,000 RPM. Check that (5) disc receiver, is the correct type as parts list and is screwed tightly to the shaft and locates the bore of the grinding wheel on the spigot of the disc receiver and screw on disc nut (4) using the spanners provided. Do not over tighten as this could crack the wheel. It should be tight enough to prevent wheel spin off when the air supply is shut off.

When first starting the grinder with a new or changed wheel fitted, the grinder should first be started in a protected area. i.e. under a bench well away from other persons and run for one minute. This will provide protection if the wheel should break because some fault was not detected.

Always use eye protection and wear protective gloves if there are sharp edges in the work area. The tool and the grinding process can create a noise level such that the use of ear protectors is advised. If the grinding process creates a dust, then use a suitable breathing mask. Check that the material being worked will not cause harmful dust or fumes. If this is so, then special breathing masks may be required. If the grinder vibrates when first fitting the wheel or during operation, remove from service immediately and correct fault before continuing to use.

Do not apply excessive pressure as this will reduce the cutting efficiency. Apply light loads to allow the wheel to cut.

Handle the grinder with care. If the grinder is dropped, carefully examine the wheel for damage and replace if necessary. Start the machine as if for the first time of fitting a wheel, i.e. under a bench.

Make sure the object to be ground is in a firm fixed position.

The lever (51) is the on/off valve for the tool. This is a governed speed controlled tool. The free running speed should be checked frequently with an accurate tachometer. If the free speed at the maximum allowed operating pressure exceeds 12,000 RPM stop using the tool and arrange for service to correct speed.

Always use the tool using the two handles, i.e. one hand on handle (6) and the other on the motor housing to control the lever (51).

An air strainer is incorporated in the inlet bushing. Check this periodically for blockage particularly if the tool slows or loses power. The strainer may be cleaned by removing the inlet bushing.

When used daily, the gears in the right angle head should be greased twice per week. Adjust the time period according to usage. To grease, remove screw (2) and inject 2 to 3 squirts of grease via screw hole. Replace screw.

Dismantling & Assembly Instructions

Disconnect tool from air supply.

Grip gear shaft (11) with spanner (33) and insert pegs on spanner (32) into the holes in disc nut (4) and unscrew disc nut (4) and take off grinding disc (28) and disc receiver (5). Remove 4 screws (30) with 4 washers (29) and take off disc guard (3), retainer (7) and gasket (8). Pull out the drive shaft assembly from housing (1). Unscrew handle (6) from housing (1) and remove 2 screws (16) and take off exhaust screen (40). Remove spacer (19).

Support bearing (14) and tap the non-threaded end of the gear shaft (11) to drive it through the bearing (14). Take off retaining ring (13) from gear shaft (11) and support bearing (9) on the threaded shaft side and press the non-threaded end of the gear shaft (11) through the assembly to separate gear shaft (11), key (12), bearing (9), bevel gear (10) and wave washer (35).

By holding housing (1) in a vise fitted with soft jaws, the control head assembly may be removed from the housing (1) by unscrewing lock ring (41). It is then possible to pull out the motor and governor assembly from the housing (1). Pull off pinion assembly from motor assembly and press apart pinion (15) and bearing (18). Grip the front plate (20) by hand and with a non-metallic or soft metal (lead or aluminium) hammer, tap the splined end of the rotor (24) to drive the rotor through the front end plate (20) and bearing (17) assembly.

Take off cylinder (23) noting its orientation to front plate (20) and rear end plate (26) for reassembly and remove 4 rotor blades (25) from rotor (24). Roll pin (22) may be removed from cylinder (23) if a replacement is required. Grip rotor (24) in a vise fitted with soft jaws and unscrew the governor assembly from the rotor (24) – left hand thread. Support the rear end plate (26) in a piece of tube with a bore diameter as close as possible to the maximum diameter of the rotor and very carefully, so as not to damage the thread, tap the rotor (24) through the rear end plate (26) and bearing (17) assembly. With a suitable punch, tap out bearing (17) from rear end plate (26) and bearing (17) from front plate (20). To dismantle the governor assembly, first unscrew adjust nut (21) from plunger (38) and adjust screw (34) assembly – do not dismantle this assembly. Take off spring (27) and drive out 2 spring pins (39) and take out 6 pendulums (37) from governor (36). When taking out the pendulums (37) take a special note of the orientation to the governor (36) to ensure that they are fitted the same way on reassembly. This is important. Grip valve housing (47) in a vise with smooth jaws on the flats and remove O-ring (31) from lock ring (41). Drive out pin (49) and remove throttle lever (51). Do not dismantle the throttle lever (51). Unscrew inlet bushing (48). Unscrew valve nut (43) and remove O-ring (44), spring (45), valve ball (46) and pin (50). Unscrew coupling nut (42) – left hand thread – from valve housing (47) and unscrew lock ring (41) from coupling nut (42).

Reassembly

Clean all parts and examine for wear. Use only distributor or manufacturer supplied spare parts. Particularly examine O-rings, bearings and gears. Coat all parts in a pneumatic tool lubricating oil, one preferably containing a rust inhibitor. Grease bearings and gears with a lithium or molybdenum based general purpose grease. Reassemble in the reverse order. See Note below.



5268

4 1/2" Angle Disc Grinder

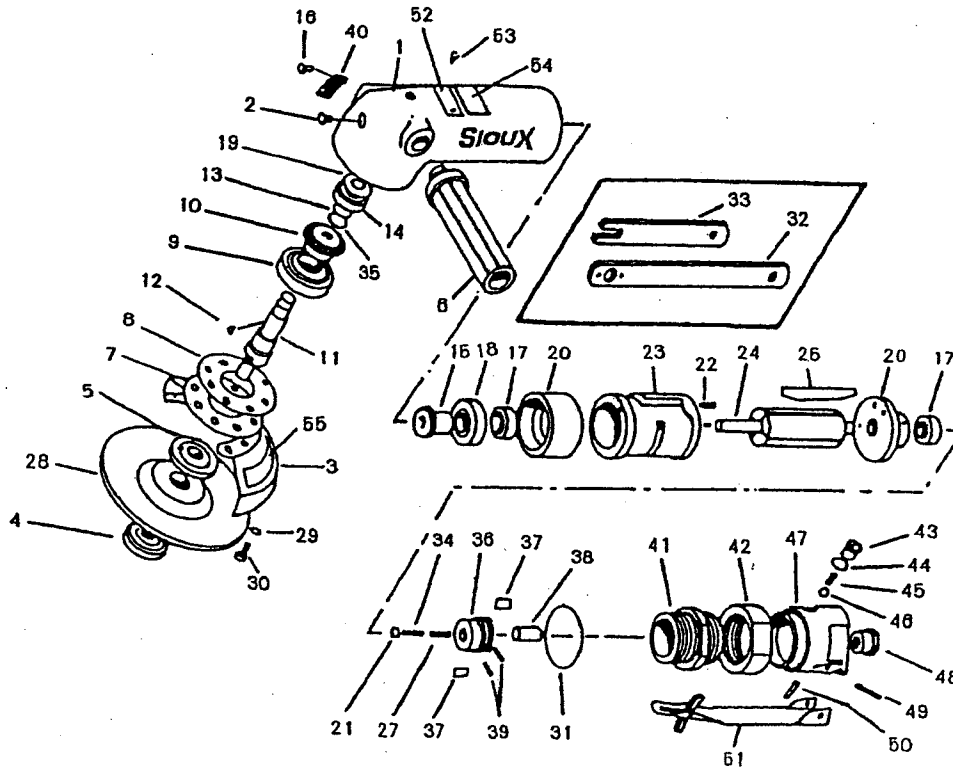

Ref. No.	Part No.	Description
1	505102	Housing
2	505103	Screw
3	505104	Guard
4	505105	Disc Nut
5	505106	Disc Receiver
6	505107	Handle
7	505108	Retainer
8	505109	Gasket
9	505110	Bearing
10	505111	Bevel Gear
11	505112	Gear Shaft
12	505113	Key
13	505114	Retaining Ring
14	505115	Bearing
15	505116	Pinion
16	505117	Screw (2)*
17	505118	Bearing (2)*
18	505119	Bearing
19	505120	Spacer
20	505121	Front Plate
21	505122	Adjust Nut
22	505123	Roll Pin
23	505124	Cylinder
24	505125	Rotor
25	505126	Rotor Blade (Set of 4)
26	505127	Rear End Plate
27	505128	Spring
28	Accessory	Disc







Ref. No.	Part No.	Description
29	505129	Washer (4)*
30	505130	Screw (4)*
31	67321	O-Ring
32	505132	Disc Spanner Wrench
33	505133	Stop Spanner Wrench
34	505134	Adjust Screw
35	505135	Wave Washer
36	505136	Governor
37	505137	Pendulum (6)*
38	505138	Plunger
39	67337	Spring Pin (2)*
40	505139	Exhaust Screen
41	505140	Lock Ring
42	505141	Coupling Nut
43	505142	Valve Nut
44	505143	O-Ring
45	505144	Valve Spring
46	505145	Valve Ball
47	505146	Valve Housing
48	505147	Inlet Bushing with Screen
49	505148	Roll Pin
50	505149	Throttle Lever Pin
51	505150	Throttle Lever
52	505099	Name Plate
53	66580	Drive Screw (2)*
54	505100	Warning Label Grinder
55	505151	Warning Label

*Order Quantity as Needed

For the motor, make sure that the end plates that abut the cylinder are free from burrs and sharp edges and if necessary lap on a flat, fine grade of abrasive paper. Press bearing (17) into rear plate (26) and support the inner race of bearing (17) and press the non-splined end of rotor (24) into the assembly. Tap the rotor relative to the rear case bearing assembly until a clearance of approx. 0.0025" (0.065mm) is achieved between the rotor and the rear case. Ensure the rotor spins freely before assembling the rest of the motor assembly. This machine has a speed controller or governor, parts (21), (34), (36), (37), (27), (38) and (39). The correct setting of this speed controller is critical to the safety of the tool and should only be carried out by a trained competent person. The speed is set by assembling the speed controller, measuring the output spindle gear shaft (11) speed with a calibrated tachometer. Adjustment to the spindle speed can be made by rotating adjust nut on adjust screw (34). The speed of the grinder running free with an air inlet pressure of 90 PSI/6.2 bar measured at inlet bushing (48) must not exceed 12,000 RPM.

Operation Specification	
Air Consumption	33 cfm (23.6 scfm)
Horse Power	0.86
Spindle Thread	5/8-11UNF
Disc Size	4 1/2" (115mm)
Air Inlet Thread	1/4-18NPT
Overall Length	10" (254mm)
at 90 PSIG	

NOTES

Manufacturer/Supplier Sioux Tools, Inc. 117 Levi Drive Murphy, NC 28906 U.S.A. Tel No. 828-835-9765 Fax No. 828-835-9685		Product Type Angle Disc Grinder 4 1/2" Dia. Disc	RPM 12,000 Cycles Per Min.	
		Model No/Nos 5268	Serial No.	
Product Net Weight 3.87 lbs 1.76 Kg	Recommended Use Of Balancer Or Support NO	Recommended Hose Bore Size - Minimum 5/16 Ins 8 M/M	Recommended Max. Hose Length 30 Ft 10 M	
Air Pressure Recommended Working 6.2 bar 90 PSI Maximum 6.2 bar 90 PSI		Noise Level: Sound Pressure Level 83.0 dB(A) Test Method: Tested in accordance with Pneurop test code PN8NTC1 and ISO Standard 3744		
SAFETY MESSAGES Personal Safety Equipment Use - Safety Glasses YES Use - Safety Gloves YES Use - Safety Boots Use - Breathing Masks YES Use - Ear Protectors YES	 WARNING  Always Read Instructions Before Using Power Tools  Always Wear Safety Goggles  Wear Hearing Protection  Avoid Prolonged Exposure To Vibration	Vibration Level 5.1 Meters / Sec ² Test Method: Tested in accordance with ISO standards 8662 Parts 1 & 4		



Declaration of Conformity
Sioux Tools Inc.
117 Levi Drive, Murphy, NC 28906, U.S.A.
declare under our sole responsibility that the product

Model 5268 Angle Disc Grinder, Serial Number
to which this declaration relates is in conformity with the following standard(s) or other normative document(s)
EN792 (Draft), EN292 Parts 1 & 2, ISO 8662 Parts 1 & 4, Pneurop PN8NTC1
following the provisions of **89/392/EEC as amended by 91/368/EEC & 93/44/EEC Directives**

Gerald E. Seebeck (President)

Name and signature or equivalent marking of authorized person