



Operator Instructions

Includes - Foreseen Use, Work Stations, Putting Into Service, Operating, Dismantling, Assembly and Safety Rules

Important

Read these instructions carefully before installing, operating, servicing or repairing this tool. Keep these instructions in a safe accessible place.

Manufacturer/Supplier Sioux Tools Inc. 2901 Floyd Boulevard P.O. Box 507 Sioux City Iowa 51102 U.S.A. Tel No 712-252-0525 Fax No 712-252-4267	Product Type High Speed Sander	RPM 14,000 Cycles Per Min	
	Model No/Nos 5540	Serial No	

Product Net Weight 2.5 lbs 1.2 Kg	Recommended Use Of Balancer Or Support No	Recommended Hose Bore Size - Minimum 5/8 Ins 8 M/M	Recommended Max. Hose Length 30 Ft 10 M
---	--	--	---

Air Pressure		Noise Level Sound Pressure Level 88.0 dB(A) Sound Power Level 99.0 dB(A)	
Recommended Working	6.2 bar 90 PSI	Test Method Tested in accordance with Pneurop test code PN8NTC1 and ISO Standard 3744	
Maximum	6.2 bar 90 PSI		

SAFETY MESSAGES Personal Safety Equipment Use - Safety Glasses Yes Use - Safety Gloves Yes Use - Safety Boots Use - Breathing Masks Yes Use - Ear Protectors	<p> WARNING Always Read Instructions Before Using Power Tools Always Wear Safety Goggles Wear Hearing Protection Avoid Prolonged Exposure To Vibration </p>	Vibration Level Less than 2.5 Metres / Sec² Test Method Tested in accordance with ISO standards 8662/1 & 8662/8
--	--	--

Safety rules when using a 5540 Sander

- Always wear safety goggles.
- Do not use as a Grinder.
- Do not use polystyrene pads.
- Use accessories rated for at least 23,000 RPM.
- Prolonged exposure to vibration may cause injury.
- Read all instructions before using this tool. All operators must be fully trained in its use and aware of these safety rules.
- Do not exceed the maximum working air pressure.
- Use personal protection equipment as recommended.
- Use only compressed air at the recommended conditions.
- If the tool appears to malfunction, remove from use immediately and arrange for service and repair. If it is not practical to remove the tool from service, then shut off the air supply to the tool and write or have written a warning note and attach it to the tool.
- If the tool is to be used with a balancer or other suspension device, ensure that the tool is firmly attached to the suspension/support device.
- When operating the tool, always keep the body and particularly the hands away from the working attachment fixed to the tool.

- The tool is not electrically insulated. Never use the tool if there is any chance of coming into contact with live electricity.
- Always when using the tool, adopt a firm footing and/or position and grip the tool sufficiently only to overcome any reaction forces that may result from the tool doing work. Do not overgrip.
- Use only correct spare parts for maintenance and repair. Do not improvise or make temporary repairs. Major servicing and repairs should only be carried out by persons trained to do so.
- Do not lock, tape, wire, etc. the 'On/Off' valve in 'On' position. The trigger lever, etc. must always be free to return to the 'Off' position when released.
- Always shut off the air supply to the tool and press the

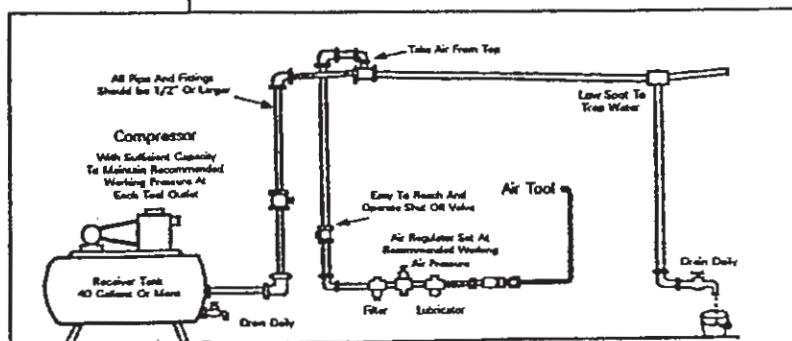

Recommended Air Supply System

Figure 1

'On/Off' valve to exhaust the air from the feed hose before fitting, removing or adjusting the working attachment fitted to the tool.

- Before using the tool make sure that a shut off device has been fitted to the supply line and the position is known and easily accessible so that the supply to the tool can be shut off in an emergency.
- Check hose and fittings regularly for wear.
- Take care against entanglement of the moving parts of the tool with clothing, hair, ties, cleaning rags, rings, jewellery, watches, bracelets, etc. This could cause the body or parts of the body to be drawn towards and in contact with the moving parts of the tool and could be very dangerous.
- It is expected that users will adopt safe working practices and observe all local, regional or country legal requirements when installing, using or maintaining the tool.
- Take care that the exhaust air does not point towards any other person or material or substance that could be contaminated by oil droplets. When first lubricating a tool or if the tool exhaust has a high oil content, do not allow the exhaust air to come near very hot surfaces or flames.
- Never lay the tool down until the working attachment has stopped moving.
- When the tool is not in use, shut off the air supply and press trigger/lever to drain the supply line. If the tool is not to be used for a period of time, first lubricate, disconnect from air supply and store in a dry average room temperature environment.
- If the tool is passed from one user to a new or inexperienced user, make sure these instructions are available to be passed with the tool.
- Do not remove any manufacturer fitted safety devices where fitted, i.e. wheel guards, safety trigger, speed governors, etc.
- Where ever possible, secure workpiece with clamps, a vise, etc. to make it rigid so it does not move during the work operation. Keep good balance at all times. Do not stretch or overreach.
- Try to match the tool to the work operation. Do not use a tool that is too light or heavy for the work operation. If in doubt, seek advice.
- In general terms this tool is not suitable for underwater use or use in explosive environments -- seek advice from manufacturer.
- Try to make sure that the work area is clear to enable the work task to be performed safely. If practical and possible, try to clear unnecessary obstructions before starting work.
- Always use air hose and couplings with minimum working pressure ratings at least 1 1/2 times the maximum working pressure rating of the tool.

Foreseen Use of the Tool

This tool is designed for use with 5" diameter coated abrasive discs of various grades of grit which are designed to be used at the same or higher speed of this tool. The tool can be used with other abrasive devices that are designed to run without a guard and have a rated speed equal to or higher than the speed of the tool. Do not attempt to use any bonded abrasive devices, i.e. grinding wheels, as those which could be fitted because of their size, cannot be used without a suitable guard. A guard is not available for this tool.

Do not fit any form of saw blade.

Do not fit any other abrasive or cutting device before checking the suitability for use with this tool with the manufacturer or the

manufacturer's authorized distributor.

Do not modify this tool for other use, or for its use as a sander/polisher before checking the intended alternative use with the manufacturer or his authorized distributor.

Work Stations

The tool should only be used as a hand held hand operated tool. It is always recommended that the tool is used when standing on a solid floor. It can be used in other positions but before any such use the operator must be in a secure position having a firm grip and footing and be aware of the safety rules to be obeyed when using the sander/polisher.

Putting Into Service

Air Supply

Use a clean lubricated air supply that will give a measured air pressure at the tool of 90 p.s.i./6.2 bar when the tool is running with the trigger/lever fully depressed. Use recommended hose size and length. It is recommended that the tool is connected to the air supply as shown in figure 1. Do not connect the tool to the air line system without incorporating an easy to reach and operate air shut off valve. The air supply should be lubricated. It is strongly recommended that an air filter, regulator, lubricator (FRL) is used as shown in Figure 1 as this will supply clean, lubricated air at the correct pressure to the tool. Details of such equipment can be obtained from your supplier. If such equipment is not used then the tool should be lubricated by shutting off the air supply to the tool, depressurising the line by pressing the trigger on the tool. Disconnect the air line and pour into the inlet bushing a teaspoonful (5ml) of a suitable pneumatic motor lubricating oil preferably incorporating a rust inhibitor. Reconnect tool to air supply and run tool slowly for a few seconds to allow air to circulate the oil. If tool is used frequently lubricate on daily basis and if tool starts to slow or lose power.

The tool incorporates an air regulator to reduce the speed of the tool if required.

Operating

Select a suitable abrasive disc (see Section 'Foreseen use of the tool') and make sure that it is fixed securely to the tool. Connect to suitable air supply as recommended.

Apply the sander lightly to the work and allow the abrasive disc to cut. Take great care when sanding around sharp edges and surfaces to avoid the disc snagging i.e. the disc may be brought to an abrupt stop or considerably slowed that will cause the tool to kick in the hands.

It is always recommended to use safety glasses and a breathing mask. The sanding of certain materials may create a hazardous dust which may require special breathing equipment. Check before using the tool. Even if the machine has a low noise level the actual sanding process may cause a noise level such that ear protectors will be required. If there are sharp areas on the material being sanded safety gloves are recommended.

Do not continue to use abrasive discs that are worn or clogged. This will make the sanding process inefficient and the need to apply unnecessarily high forces to the tool.

Do not use undersized or oversized sanding discs. The disc should be no more than 1/4" larger in diameter than the pad, and not smaller than the pad.

The trigger (12) is the on/off valve for the tool. The speed/power of the tool may be controlled by rotating air regulator (5).

Note: Place sanding disc against correct side of backing disc. Orientate and stack backing discs as shown in the parts list. Never use only one disc. For use with 5" sanding discs always use the 3" disc pad and 4 1/2" disc pad together.

Dismantling & Assembly Instructions

Disconnect tool from air supply. Grip motor housing (1) in a vise fitted with soft jaws and unscrew inlet bushing (6). Drive out retaining ring (3)



5540

High-Speed Sander

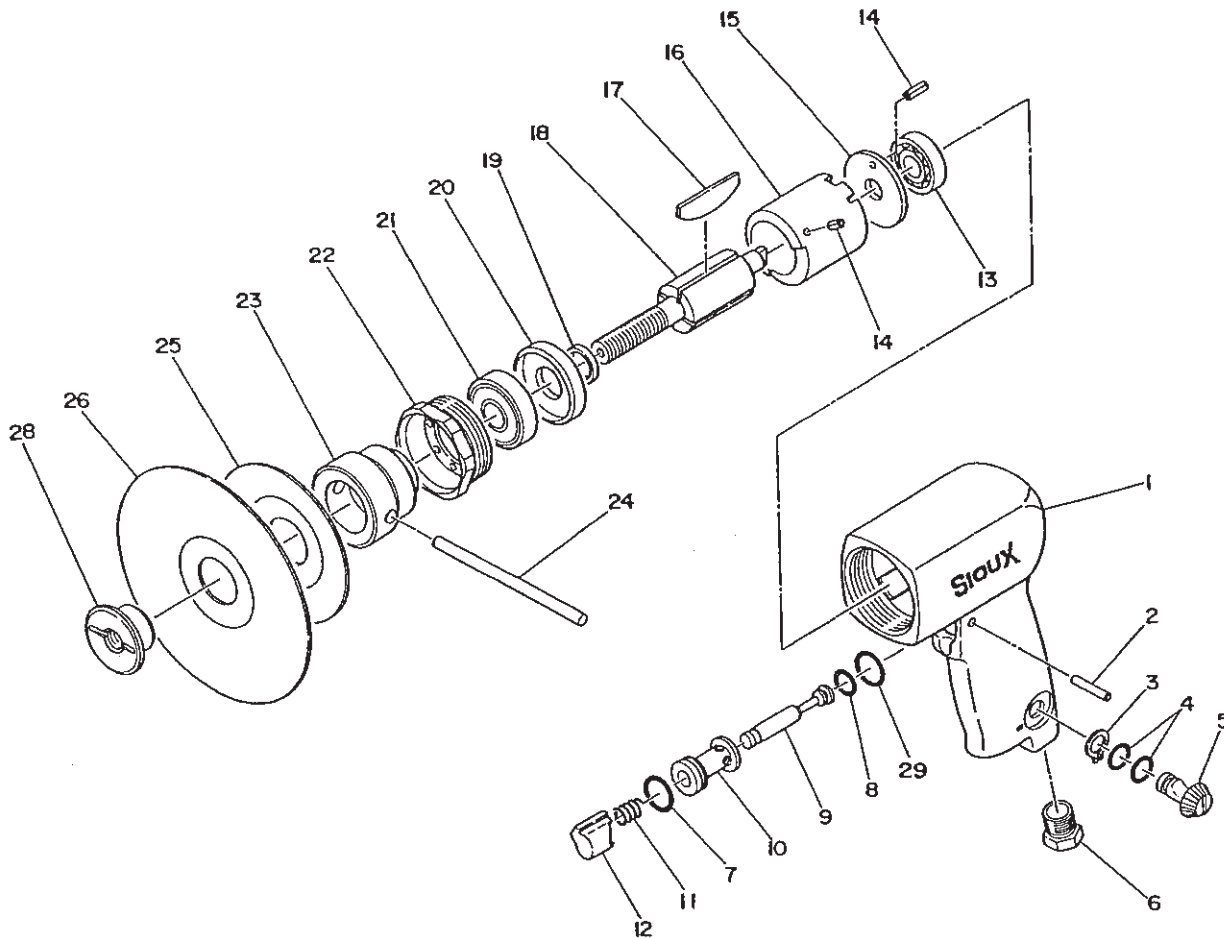

Ref No	Part No	Description
1	67498	Housing
2	67485	Pin
3	67499	Retaining Ring
4	67037	O-Ring (2) *
5	67501	Air Regulator
6	67084	Bushing
7	67502	O-Ring
8	67077	O-Ring
9	67503	Valve Stem
10	67504	Valve Bushing
11	67505	Spring
12	67506	Trigger
13	67507	Ball Bearing
14	67508	Roll Pin
15	67509	Rear Plate
16	67510	Cylinder

Ref No	Part No	Description
17	67325	Rotor Blade (Set of 4)
18	67512	Rotor
19	67513	Spacer
20	67514	Front Plate
21	67515	Ball Bearing
22	67516	Lock Ring
23	67517	Hub
24	67518	Hub Wrench
25	67519	Disc Pad 3"
26	67520	Disc Pad 4-1/2"
28	67521	Disc Nut
29	67522	O-Ring
	Not Shown	
	67523	Name Plate
	67500	Warning Label

※Order quantity as needed

and unscrew and remove regulator (5) with O-ring (4). Drive out pin (2) and grip trigger (12) and pull out the complete trigger assembly. Grip valve stem (9) and pull off trigger (12) to release spring (11). Slide valve stem (9) through valve bushing (10) and remove O-ring (7) from valve bushing (10) and O-ring (8) from valve stem (9). Take out O-ring (29) from housing (1). Insert hub wrench (24) through hole in hub (23) and unscrew disc nut (28) and remove abrasive paper disc as fitted and disc pad (25) and (26).

Unscrew lock ring (22) from housing (1) and pull out the complete motor assembly and note how roll pin (14) in the side of cylinder (16) locates the motor assembly via the slot in motor housing (1). Grip the flats on the end of rotor (18) and unscrew hub (23) and remove lock ring (22). Grip rear end plate (15) and tap the end of rotor (18) to drive it through the rear end plate (15) and bearing (13). Remove cylinder (16) noting how it locates to rear end plate (15) via roll pin (14). Take out 4 off rotor blades (17) from rotor (18) and tap the threaded end of rotor (18) to drive it through bearing (21), front plate (20) and spacer (19).

Reassembly

Clean all parts and examine for wear. Use only replacement parts obtained from the manufacturer or authorised distributor. Coat all parts in a suitable pneumatic tool lubricating oil and assemble in the reverse order. With trigger (12) depressed, pour into inlet bushing (6) 5ml of a pneumatic tool lubricating oil and connect to a suitable air supply and run tool for 2 to 3 seconds to allow the oil to circulate and check the function of the trigger and reversing valve.

Operation Specification *	
Air Consumption	12 CFM
Length	4.3" (110mm)
Air Inlet Thread	1/4-18 NPT
* at 90 PSIG	

Notes

Declaration of Conformity

Sioux Tools Inc.

2901 Floyd Boulevard, P.O. Box 507, Sioux City, Iowa 51102, U.S.A.

declare under our sole responsibility that the product

Model 5540 High-Speed Sander, Serial Number

to which this declaration relates is in conformity with the following standard(s) or other normative document(s)

EN792 (Draft), EN292 Parts 1 & 2, ISO 8662 Parts 1 & 8, Pneurop PN8NTC 1

following the provisions of **89/392/EEC as amended by 91/368/EEC & 93/44/EEC Directives**

R.V. Caskey (V.P./General Manager)

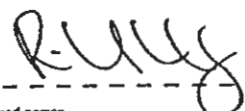

Name and signature or equivalent marking of authorised person