

# Service Manual

Cordless Hammer Drill &amp; Driver

EY6930

## CONTENTS

	Page
• Specifications .....	1
• Disassembly & Assembly Instructions .....	2 - 6
• Wiring Connection Diagram .....	7
• Schematic Diagram .....	7
• Troubleshooting .....	8 - 10
• Exploded View .....	11
• Replacement Parts List .....	12

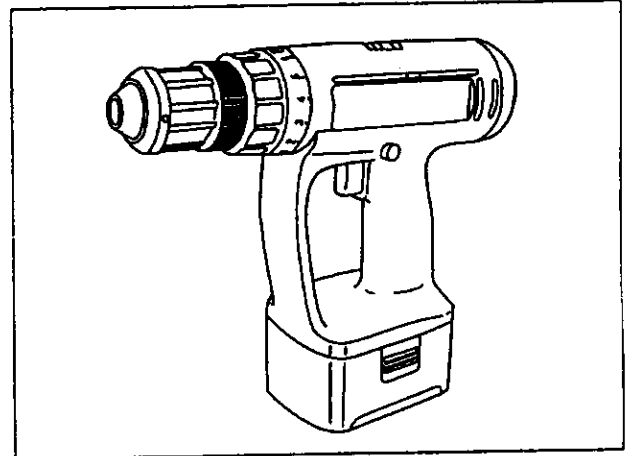

## SPECIFICATIONS

<b>DRILL/DRIVER</b>			
Capability	(Screw driving)	: Machine screw	M3.5 - M6
		Wood screw	φ2.1 - φ 6.8mm (5/64" - 17/64")
	(Drilling)	: Mortar brick	φ3.0 - φ13.0mm (1/8" - 1/2")
		Wood	φ3.0 - φ27.0mm (1/8" - 1/32")
		Steel	φ1.5 - φ13.0mm (1/16" - 1/2")
Motor voltage		: 15.6V DC	
No load speed		LOW : 70 ~ 570 min <sup>-1</sup> (r.p.m.)	
		HIGH : 270 ~ 2,000 min <sup>-1</sup> (r.p.m.)	
Blows rate per minute		LOW : 1,050 - 8,550 min <sup>-1</sup> (b.p.m.)	
		HIGH : 4,050 - 30,000 min <sup>-1</sup> (b.p.m.)	
Chuck capacity		: 1.5mm - 13mm (1/16" - 1/2")	
Maximum torque		LOW : 22.5Nm (230kg-cm, 199in.lbs.)	
		HIGH : 5.9Nm (60kg-cm, 52in.lbs.)	
Blow strength		: 1.7kN (170kgf, 370lbs.f)	
Overall length		: 263mm (10-1/64")	
Weight (with battery pack)		: 2.35kg (5.2lbs.)	
<b>BATTERY PACK</b>			
Storage battery		: Ni-Cd battery	
Battery voltage		: 15.6V DC ( 1.2V × 13 cells)	
Weight		: 1.0kg	
<b>BATTERY CHARGER</b>			
Input		: 120V AC	
Weight		: 1.70kg (3.80lbs.)	
Charging time		: Approx. 30 min. for EY9136	

### STANDARD EQUIPMENT

Battery charger , Battery pack , Tool case

# Panasonic

© 1997 Matsushita Electric Works, Ltd.  
All rights reserved. Unauthorized copying and  
distribution is a violation of law.

**⚠ WARNING**

This service literature is designed for experienced repair technicians only and is not designed for use by the general public. It does not contain warnings or cautions to advise non-technical individuals of potential dangers in attempting to service a product. Products powered by electricity should be serviced or repaired only by experienced professional technicians. Any attempt to service or repair the product or products dealt with in this service information by anyone else could result in serious injury or death.

**DISASSEMBLY INSTRUCTIONS**

**■ HOW TO REMOVE THE KEYLESS DRILL CHUCK.**

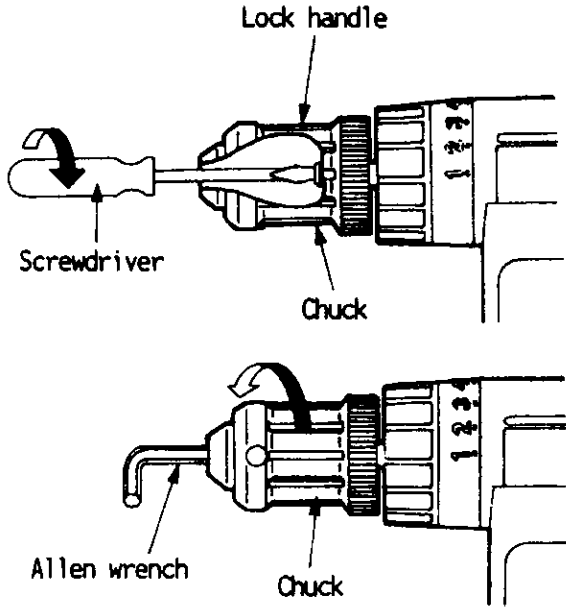
Ref. No. 1A	Procedure 1A	Removal of the keyless drill chuck.
		<ol style="list-style-type: none"> <li>1. Set the clutch handle to drill position.</li> <li>2. Turn the lock handle in the counterclockwise direction to open the chuck claws.</li> <li>3. Remove the chuck fastening screw inside the chuck by turning it in the clockwise direction with a slotted head screwdriver.</li> </ol> <p>NOTE : If the chuck fastening screw will not come loose, insert the allen wrench into the chuck and lightly tap in the clockwise direction with a hammer to tighten the chuck, and then loosen the chuck fastening screw.</p> <ol style="list-style-type: none"> <li>4. Insert the allen wrench into the chuck, and turn in the counterclockwise direction, holding the unit by the vise to remove the chuck.</li> </ol>

**■ HOW TO DISASSEMBLE THE MAIN UNIT. (Housing AB set can be opened without disassembling the chuck.)**

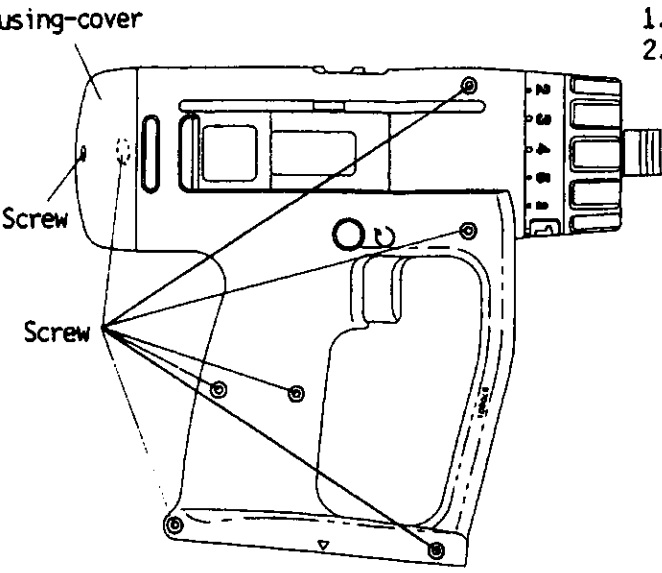
Ref. No. 1B	Procedure 1B	Removal of the housings.
		<ol style="list-style-type: none"> <li>1. Remove 2 screws of the housing cover.</li> <li>2. Remove 8 screws of the housing.</li> </ol>

Ref. No. 2B	Procedure 1B → 2B	Removal or assembly of the motor.
-------------	-------------------	-----------------------------------

- (Removal of the motor.)
1. Remove the motor with the gear block from the housing.
  2. Separate the motor from the gear block by twisting the motor to unlock tabs.

- (Assembly of the motor.)
3. Align the raised line of the gear block with the line of the motor.

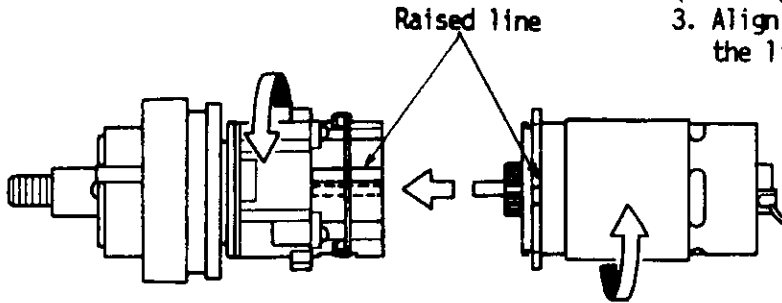

Ref. No. 3B	Procedure 1B → 2B → 3B	Removal of the driving block.
-------------	------------------------	-------------------------------

1. Set the clutch handle B to position 1 before replacing the driving block from the housing.
2. Loosen 3 screws of clutch handle A and remove the clutch handle from the driving block.
3. Pull out 2 pins ( $\phi 2 \times 31.8$ ) by pressing down on the clutch handle B and the driving shaft.
4. After removing the clutch handle B, the internal parts of the driving block can be removed one after another.

driving shaft → spring → change plate (2pcs) → cam A → vibration spring → click plate → adjust ring → clutch spring → clutch plate → steel ball (12pcs) → roller pin (6pcs)

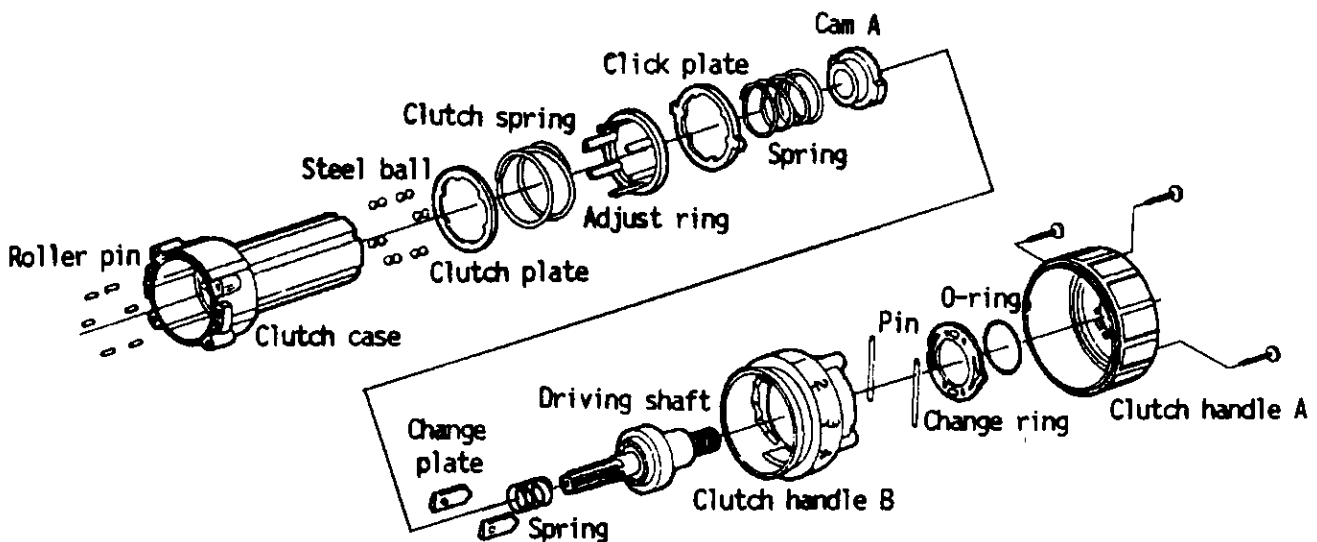
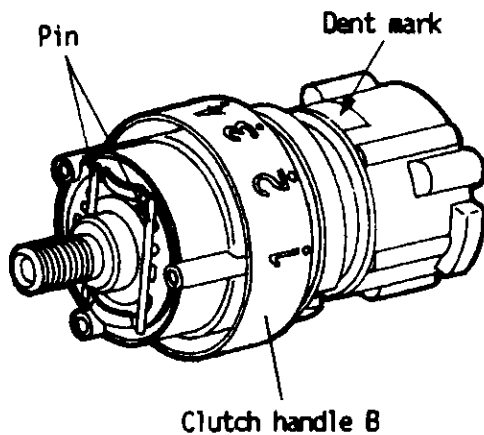

ASSEMBLY INSTRUCTIONS

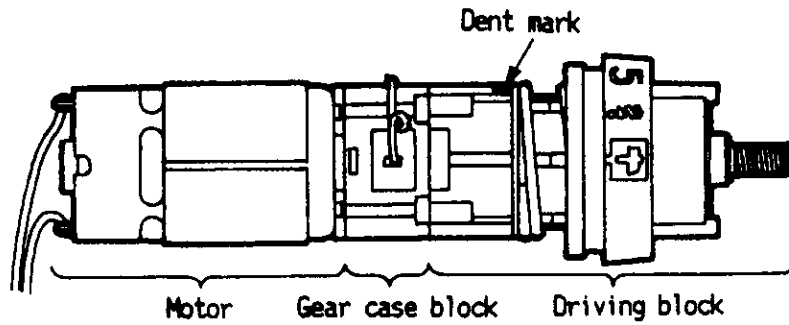

※ Use the grease (EY6811X5537/aero shell grease ASG22) onto the cam A, cam B, and change plate. Use the grease (EY6705X5527/sun light grease No. 2 ) into the gear case block.

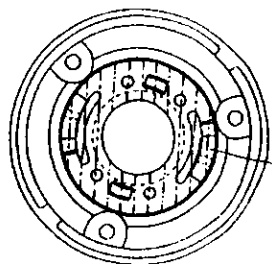
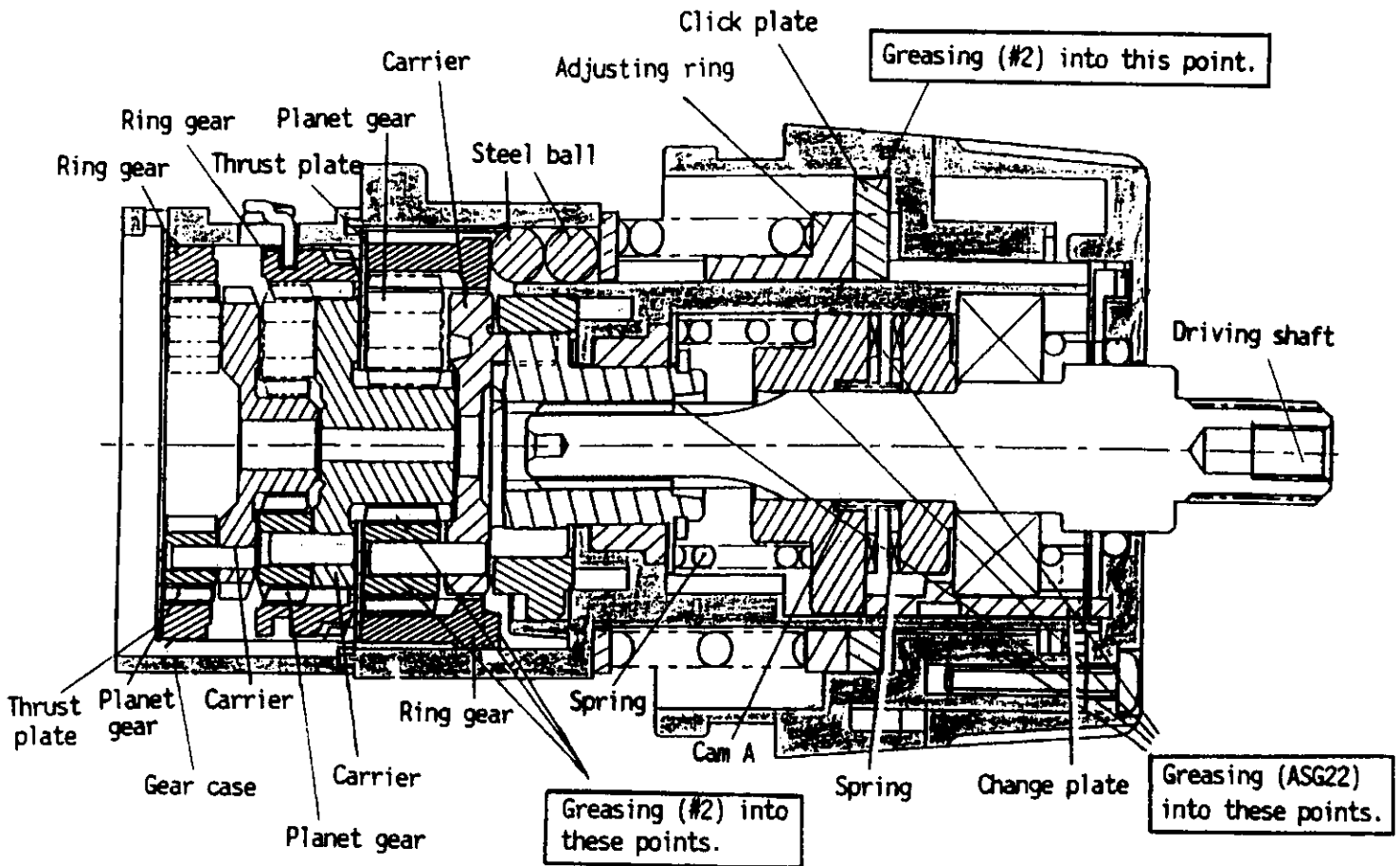

■ HOW TO ASSEMBLE THE DRIVING BLOCK AND GEAR CASE ASSEMBLY.

Ref. No. 1A	Procedure 1A	Assembly of the driving block.
	<p>1. Assemble the clutch plate, clutch spring, and the adjust ring to the outside of the clutch case.</p> <p>2. The click plate has its own correct direction for proper assembly. Adjust the (A) groove of the clutch case to the protrusion part of the click plate.</p>	<p>3. Assemble the vibration spring and cam A into the clutch case.</p> <p>4. When assembling the change plates, make sure that the protrusion side of the change plates face inside of the clutch case.</p> <p>5. Insert the spring to the driving shaft and assemble them to the clutch case.</p>

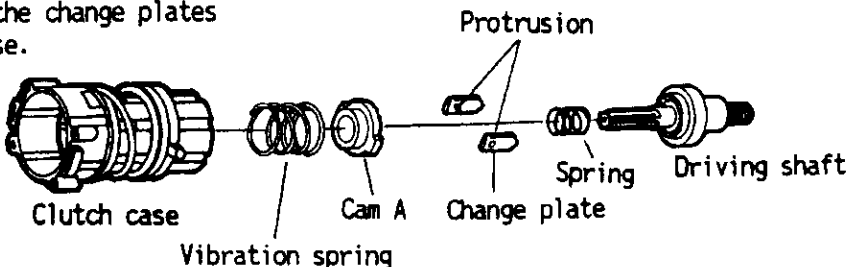
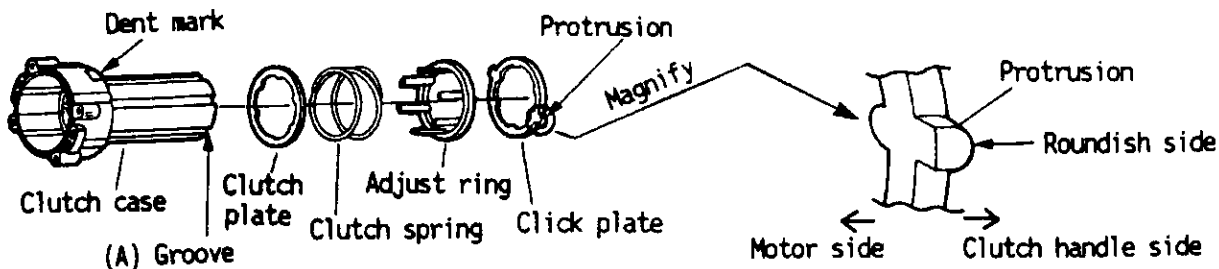

Ref. No. 2A	Procedure 1A → 2A	Assembly of the clutch handle.
  		<p>1. Set the clutch handle B to position 1 toward the dent part of the clutch case.</p> <p>2. Insert 2 pins (<math>\phi 2 \times 31.8</math>) by pressing down the clutch handle B and the driving shaft.</p> <p>3. The change ring has its own correct direction. Confirm the direction when the change ring is inserted into the clutch handle.</p> <p>4. Select the clutch handle B to the hammer position before assembling the clutch handle A to the gear block.</p> <p>5. Adjust the protrusion parts of the change plate with the groove parts of the change ring inside of the clutch handle A.</p> <p>6. Tighten the 3 screws of clutch handle A.</p>

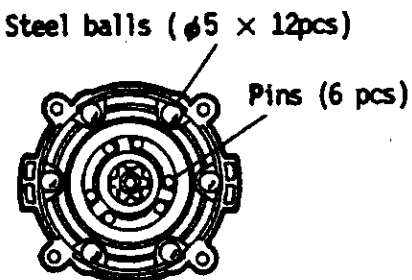
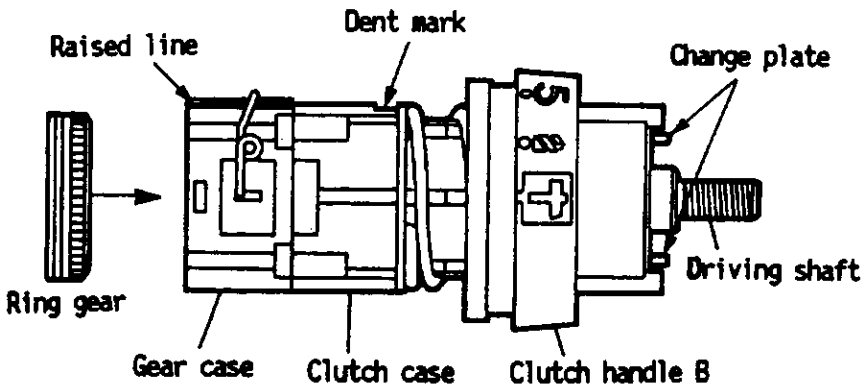
Ref. No. 3A	Procedure 1A → 2A → 3A	Assembly of the gear case.
 <p>Steel balls (φ5 × 12pcs)</p> <p>Pins (6 pcs)</p>		<ol style="list-style-type: none"> <li>1. Reinstall 2 pieces of steel balls into each of the 6 holes.</li> <li>2. Insert 6 pins into the clutch case.</li> <li>3. Assemble the carrier, ring gear and 3 pieces of planet gear.</li> <li>4. Align the dent part of the clutch case with the raised line of the gear case. And tighten them with 4 screws.</li> <li>5. Assemble the ring gear B, carrier A, planet gear A, carrier B, ring gear A, planet gear B, and thrust plate.</li> </ol> <p>Note : Ring gear B has its own correct direction for proper assembly.</p>
 <p>Raised line</p> <p>Dent mark</p> <p>Change plate</p> <p>Ring gear</p> <p>Gear case</p> <p>Clutch case</p> <p>Clutch handle B</p> <p>Driving shaft</p>		

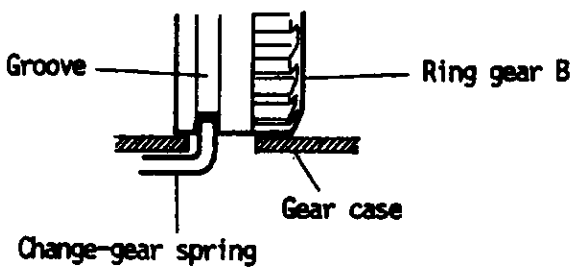
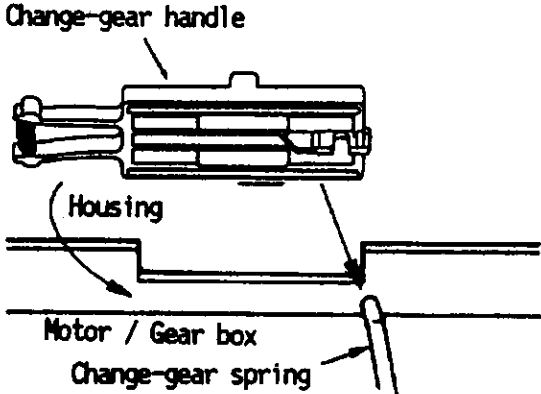
Ref. No. 4A	Procedure 1A → 2A → 3A → 4A	Assembly of the change-gear spring and handle.
 <p>Groove</p> <p>Ring gear B</p> <p>Gear case</p> <p>Change-gear spring</p>		<ol style="list-style-type: none"> <li>1. Change-gear spring has its own correct direction when inserting it into the housing. Both ends of spring must be put into the grooves of the ring gear B.</li> <li>2. Confirm the proper position of the change-gear handle when it is assembled.</li> </ol>
 <p>Change-gear handle</p> <p>Housing</p> <p>Motor / Gear box</p> <p>Change-gear spring</p>		

**SCHEMATIC DIAGRAM**

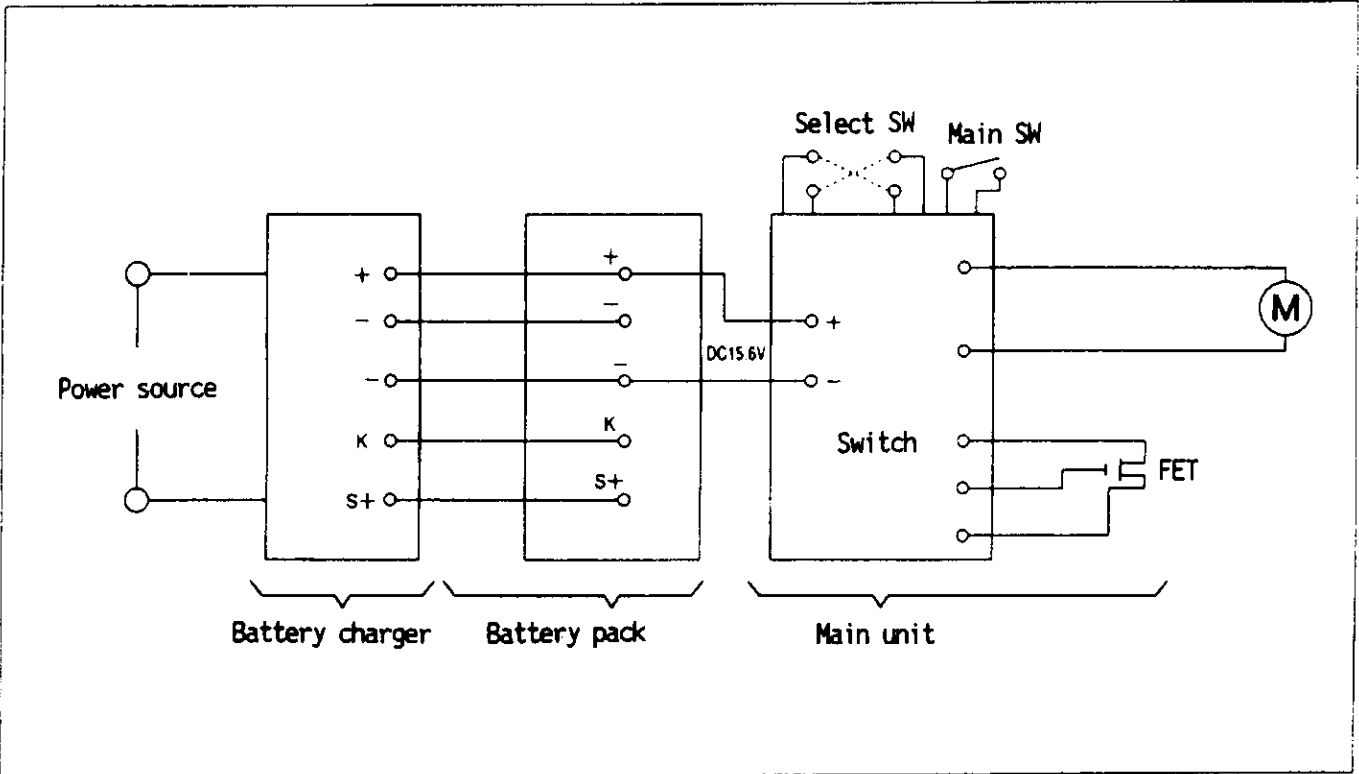

**WIRING CONNECTION DIAGRAM**

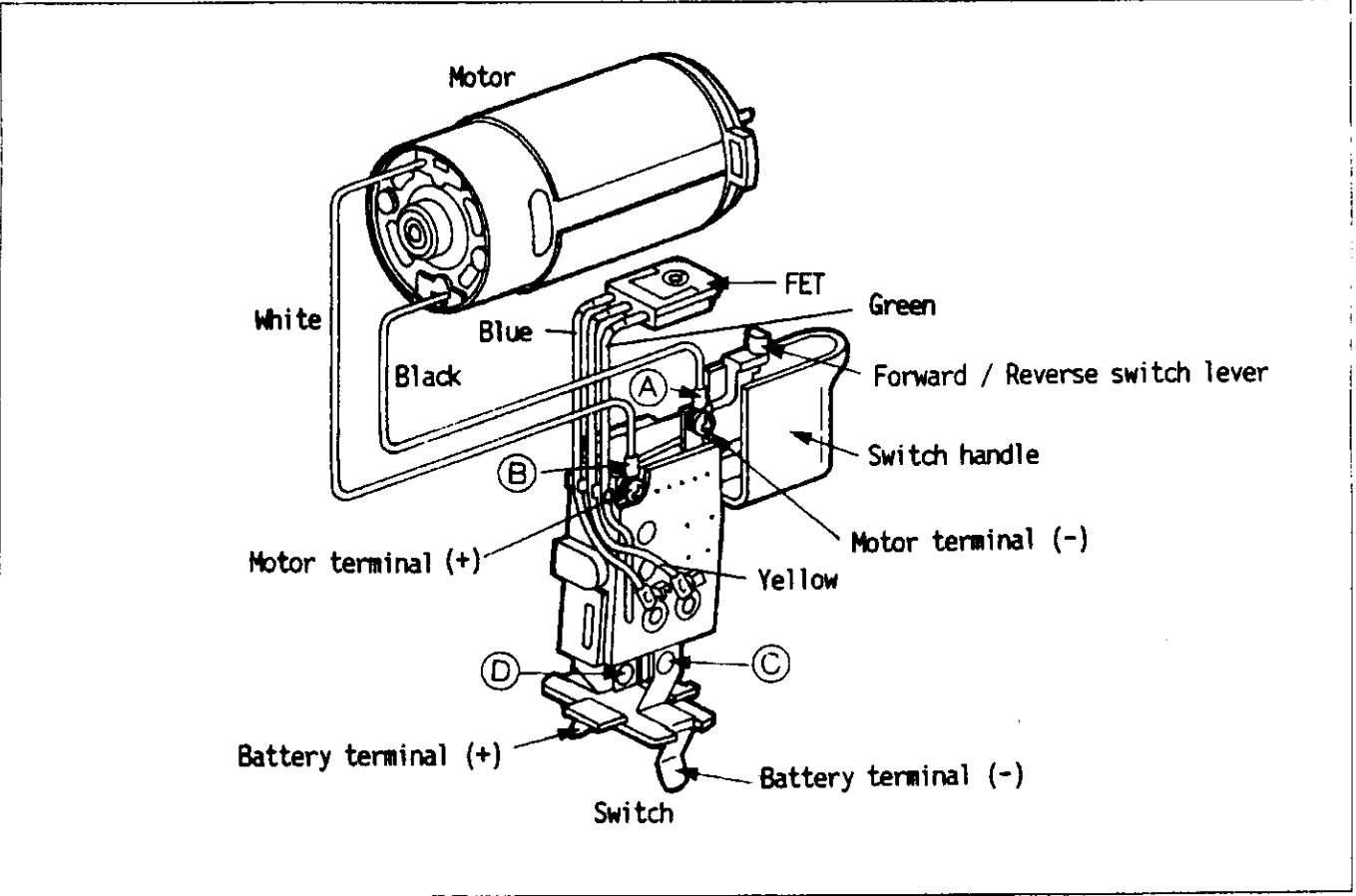

**TROUBLESHOOTING GUIDE ( Refer to WIRING CONNECTION DIAGRAM )**

■ CHECK POINTS FOR ELECTRICAL PARTS

< TROUBLE >

< CHECK >

< REMEDY >

Does not operate.

**<CHECK BATTERY PACK.>**  
 If no less than 15.6V DC is available across the (+) and (-) terminals, the battery pack is OK.  
 Note: The battery pack is sold separately as shown in REPLACEMENT PARTS LIST. The battery pack has a limited life. The pack should be replaced if

- after being charged for the rated charging time the battery voltage is less than 15.6V DC or the usable time is extremely short.
- the battery leaks. Check battery for leaks and terminals for corrosion.

NO  
 Replace battery pack.

OK

**<CHECK TERMINAL CONNECTIONS BETWEEN MAIN UNIT AND BATTERY PACK.>**  
 Check for proper terminal contacts.

NO  
 Repair the contacts.

OK

**<CHECK SWITCH BLOCK.>**  
 ( See WIRING CONNECTION DIAGRAM. )  
 Check continuity between following terminals.  
 \* Inspection of the forward / reverse selection switch.  
 When the switch handle is depressed all the way :

- There should be 0Ω between (A) - (D), and between (B) - (C) ; when the switch lever is set to the forward side.
- There should be 0Ω between (A) - (C), and between (B) - (D) ; when the switch lever is set to the reverse side.

NO  
 Replace the switch & FET block.

OK

**<CHECK MOTOR.>**  
 The motor normally operates with its red (+) and blue (-) lead wires connected to 15.6V DC.  
 ref. : motor rotating speed 19,000 - 1,900rpm

NO  
 Replace the motor.

OK

Does not speed-control.

**<CHECK SWITCH BLOCK.>**  
 Though FET block may be defective, FET block can not be replaced without replacing the switch block.

NO  
 Replace the switch & FET block.



■ CHECK POINTS FOR DRIVING BLOCK  
< TROUBLE >

< CHECK >

< REMEDY >

Does not vibrate or weakness of vibration. (When setting the clutch handle to )

<CHECK DRIVING SHAFT (CAM B) AND CAM A.>  
Check the wear condition of the driving shaft (cam B) and the cam A inside of the clutch case.

NO  
Replace driving shaft or cam A.

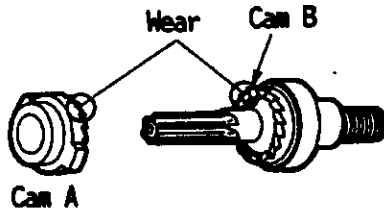

< part of cam A and B >

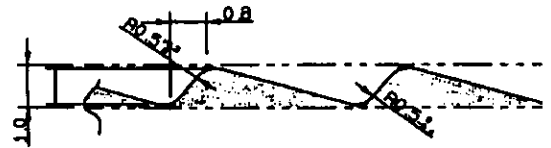

OK

<CHECK CHANGE PLATES.>  
Check the wear condition of protrusion parts for both side of change plates.

NO  
Replace change plates.

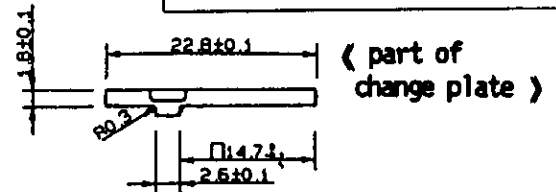

Weakness of clutch operation.

<CHECK CLUTCH HANDLE A.>  
Check the wear condition of torque changing cam inside of clutch handle A.

NO  
Replace clutch handle A.

OK

<CHECK RING GEAR.>  
Check the wear condition of the protrusion parts of ring gear.

NO  
Replace ring gear.

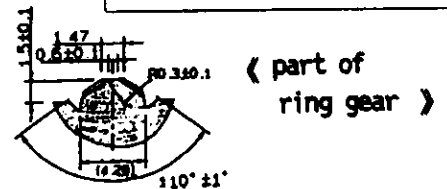
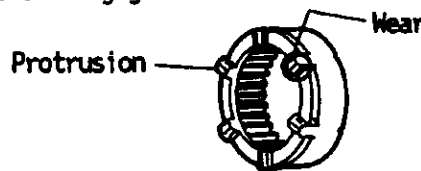

OK

<CHECK ADJUST RING.>  
Check the wear condition of tip parts of adjust ring.

NO  
Replace adjust ring.

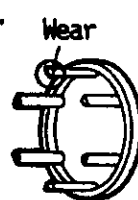

< part of adjust ring >

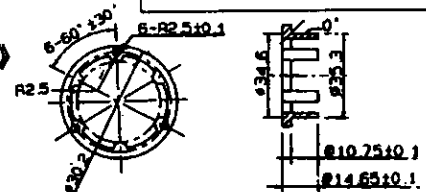



The bit-locking function does not work.

<CHECK ROLLER AND CARRIER.>  
Check the wear condition of roller set and carrier.

NO  
Replace roller set or carrier.

**TRIAL OPERATION ( After checking TROUBLESHOOTING GUIDE. )**

- ① Check the vibrating operation by setting the clutch handle to , then touching the bit on a board.  
Impact rate per minutes : HIGH 4,050 - 30,000 b.p.m.    LOW 1,050 - 8,850 b.p.m.  
Impact strength : 1,7kN (170kgf)
- ② Check the clutch operation by setting the clutch handle between 1 - 5.  
clutch torque : 5 steps (approx. 1.0 - 1.5 - 2.5 - 3.4 - 4.4 Nm)  
(approx. 10 - 15 - 25 - 34 - 45 kg-cm)
- ③ Check the rotation of clutch (without clutch operation) by setting to .
- ④ Check the speed control in proportion to the depression amount of the switch handle.  
LOW : approx. 270 - 2,000 r.p.m.  
HIGH : approx. 70 - 570 r.p.m.
- ⑤ Check the operation by selecting the forward or reverse switch.
- ⑥ Check if the 3 chuck claws open or close smoothly by turning lock handle.  
chuck capacity :  $\phi$  1.5 - 13 mm
- ⑦ Screwdriver bit locks in place, check if it is locked and can be used as a manual screwdriver.  
torque : max. 22.6Nm (230kgf-cm)

EXPLODED VIEW

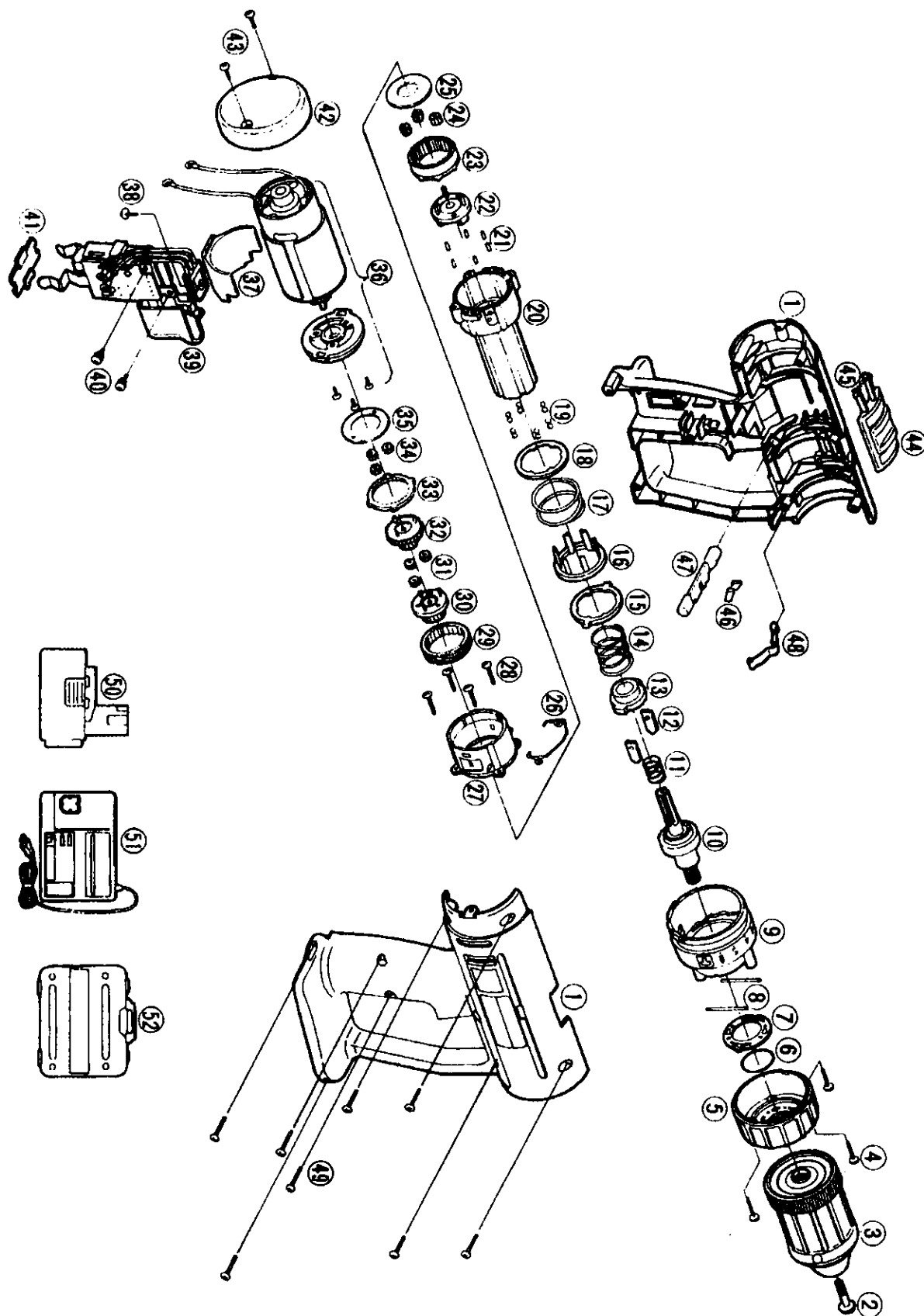

## REPLACEMENT PARTS LIST

NOTE : \*A . . . available as an optional accessory  
 \*B . . . only available as set  
 \*C . . . available individually

Ref. No.	Part No.	Part Name & Descriptions	Per unit	Remarks
▲ 1	EY6930K3078	HOUSING AB SET	1	
2	EY6230L6817	CHUCK FASTENING SCREW	1	
3	EY6930K7917	KEYLESS DRILL CHUCK	1	
4	EY6930K9157	SCREW	3	*C
5	EY6901H3227	CLUTCH HANDLE A	1	
6	EY509B0977	O-RING	1	
7	EY6901L0567	CHANGE RING	1	
8	EY6901L0357	PIN	2	*B (2PCS/PACK)
9	EY6930H3258	CLUTCH HANDLE B	1	
10	EY6901L1137	DRIVING SHAFT	1	
11	EY6900B0177	SPRING	1	
12	EY6901L0907	CHANGE PLATE	2	*B (2PCS/PACK)
13	EY6901L1387	CAM A	1	
14	EY6901L0197	SPRING	1	
15	EY6901L0457	CLICK PLATE	1	
16	EY6901L0637	ADJUST RING	1	
17	EY6901L0167	CLUTCH SPRING	1	
18	EY6901L0577	CLUTCH PLATE	1	
19	EY560B6967	STEEL BALL	12	*B (12PCS/PACK)
20	EY6901L1797	CLUTCH CASE	1	
21	EY6705L0377	ROLLER PIN	6	*B (6PCS/PACK)
22	EY6901L1107	CARRIER	1	
23	EY6901L1477	RING GEAR	1	
24	EY6900B1347	PLANET GEAR SET	3	*B (3PCS/PACK)
25	EY6200B0857	THRUST PLATE	1	
26	EY6207B1517	CHANGE-GEAR SPRING	1	
27	EY6700B1768	GEAR CASE	1	
28	EY6930L9577	SCREW	4	*C
29	EY560B1467	RING GEAR B	1	
30	EY6401L1357	CARRIER	1	
31	EY6200B1357	PLANET GEAR	3	*B (3PCS/PACK)
32	EY6900B1127	CARRIER B	1	
33	EY6930B1457	RING GEAR A	1	
34	EY560B1367	PLANET GEAR B	3	*B (3PCS/PACK)
35	EY6901L0887	THRUST PLATE	1	
36	EY6930L1008	MOTOR	1	
37	EY6901L2567	RADIATING PLATE	1	
38	EY6230L6017	SEMS SCREW	1	
▲ 39	EY6230Y2008	SWITCH BLOCK	1	
40	EY6230L6037	SEMS SCREW	2	*C
41	EY6230L0207	DUST PREVENTIVE PLATE	1	
42	EY6230H3107	HOUSING COVER	1	
43	EY6230K9038	SCREW	2	*C
44	EY6901H3237	CHANGE-GEAR HANDLE	1	
45	EY560B0187	SPRING	1	
▲ 46	EY6481L0177	CLICK SPRING	1	
47	EY6901H3247	FORWARD/REVERSE SELECTOR HANDLE	1	
48	EY6930L0177	CLICK SPRING A	1	
▲ 49	EY6230K9218	SCREW	9	*C
50	EY9136	BATTERY PACK	1	*A ACCESSORY
51	EY0212	BATTERY CHARGER	1	*A ACCESSORY
52	EY9630	TOOL CASE	1	
▲ -	EY6930K8008	INDIVIDUAL BOX	1	
▲ -	EY6930K8108	OPERATING INSTRUCTIONS	1	