

## PROFI LIFTER 2600 / 4400 PROFI PULLER 4000 / 6600

### PROFI LIFTER 2600 / 4400:

JDN Lifting Winches in a compact very durable steel structure with capacities of **2600 lbs** and **4400 lbs**.

Explosion classification for the standard models:

⊕ II 2 GD IIA T4(X) / II 3 GD II B T4(X),

with increased spark protection:

⊕ II 2 GD IIB T4(X).

Winches with hydraulic drive on request.

### PROFI PULLER 4000 / 6600:

JDN Pulling Winches in a compact very durable steel structure with capacities of **4000 lbs** and **6600 lbs**.

Explosion classification for the standard models:

⊕ II 2 GD IIA T4(X) / II 3 GD II B T4(X),

with increased spark protection:

⊕ II 2 GD IIB T4(X).

Winches with hydraulic drive on request.

## TECHNICAL DATA

Type	PROFI LIFTER 2600	PROFI LIFTER 4400	PROFI PULLER 4000	PROFI PULLER 6600
Nominal pressure (required static pressure)	85 6	85 6	85 6	85 6
Capacity (nominal load for lifting winches) in the last layer	2600	4400	–	–
Pulling capacity (nominal load for Pulling winches) in the first layer	–	–	4000	6600
Max. number of rope layers	4	4	4	4
Max. motor power	2.2	2.6	2.2	2.6
Lifting respectively pulling speed without load <sup>2</sup>	60.7	42.6	60.7	42.6
Lifting respectively pulling speed at 80 % of the nominal load <sup>2</sup>	43.6	28.9	32.2	19.7
Lifting respectively pulling speed at nominal load <sup>2</sup>	38.1	26.3	23	15.1
Lowering respectively unwinding speed without load <sup>2</sup>	53.2	41.0	53.2	41.0
Lowering speed at nominal load <sup>2</sup>	73.8	55.1	–	–
Air connection	G <sup>3</sup> /4	G1	G <sup>3</sup> /4	G1
Air consumption at nominal load - pulling	–	–	120.1	141.3
Air consumption at nominal load - lifting	137.7	158.9	–	–
Air consumption without load - pulling	–	–	162.5	176.6
Air consumption without load - lifting	162.5	176.6	–	–
Air consumption without load - lowering	148.3	151.9	–	–
Air consumption at nominal load - lowering	180.1	194.2	–	–
Hose size (ø inside / ø outside)	0.8/1.2	1/1.5	0.8/1.2	1/1.5
Rope drum diameter	9.5	11.2	9.5	11.2
Rope diameter	64.6	68.8	68.8	68.8
Max. possible rope diameter	7/16	1/2	7/16	1/2
Minimum breaking force of rope	13219	22054	11915	19851
Weight (without rope and additional devices) short drum version	304.2	518.1	304.2	518.1
Weight (without rope and additional devices) long drum version	348.3	683.4	348.3	683.4
Control length for pendant control	6.6	6.6	6.6	6.6
Noise pressure level without load - lifting or pulling <sup>1</sup>	88	87	88	87
Noise pressure level without load - lowering or unwinding <sup>1</sup>	90	88	90	88
Noise pressure level at nominal load - lifting or pulling <sup>1</sup>	86	85	82	80
Noise pressure level at nominal load - lowering <sup>1</sup>	92	88	–	–

<sup>1</sup> Measured at 1 m distance acc. to DIN 45635 part 20

<sup>2</sup> Measured in the first layer with max. rope diameter (further data see section curves)

## THE ADVANTAGES AT A GLANCE

- ⇒ Drum integrated exhaust air cooled planetary gear for minimum maintenance and maximum reliability at a duty cycle of 100 %
- ⇒ High rope capacity at a 4-layer spooling
- ⇒ Ideal ratio of drum/rope diameter (D/d=21) ensures a long duty cycle of the rope
- ⇒ Variable speeds, easy to install, low noise level
- ⇒ Integrated overload protection
- ⇒ Low air consumption
- ⇒ Ideal for applications in hazardous areas
- ⇒ Various options





PROFI LIFTER 2600



PROFI PULLER 4000

**PERFORMANCE DATA**

PROFI LIFTER 2600 (M3)					
Rope diameter 3/8"		Speeds [ft/min]			
		Lifting		Lowering	
Rope Layer		1. Layer	4. Layer	1. Layer	4. Layer
Load condition [lbs]	0	62.1	77.0	53.4	66.2
	1300	47.8	55.0	65.4	84.7
	2600	33.5	33.1	77.5	103.3
	3300	25.9	–	84.0	–

PROFI PULLER 4000 (M3)					
Rope diameter 3/8"		Speeds [ft/min]			
		Pulling		Unwinding	
Rope Layer		1. Layer	4. Layer	1. Layer	4. Layer
Load condition [lbs]	0	62.2	77.0	53.4	66.2
	1300	47.8	55.0	–	–
	2600	33.5	33.1	–	–
	4000	18.2	–	–	–

PROFI LIFTER 4400 (M3)					
Rope diameter 1/2"		Speeds [ft/min]			
		Pulling		Unwinding	
Rope Layer		1. Layer	4. Layer	1. Layer	4. Layer
Load condition [lbs]	0	42.4	53.5	41.3	52.2
	2200	33.1	38.6	49.0	64.4
	4400	23.8	23.8	56.7	76.6
	5500	19.1	–	60.5	–

PROFI PULLER 6600 (M3)					
Rope diameter 1/2"		Speeds [ft/min]			
		Pulling		Unwinding	
Rope Layer		1. Layer	4. Layer	1. Layer	4. Layer
Load condition [lbs]	0	42.4	53.5	41.3	52.2
	2200	33.1	38.6	–	–
	4400	23.8	23.8	–	–
	6600	14.4	–	–	–

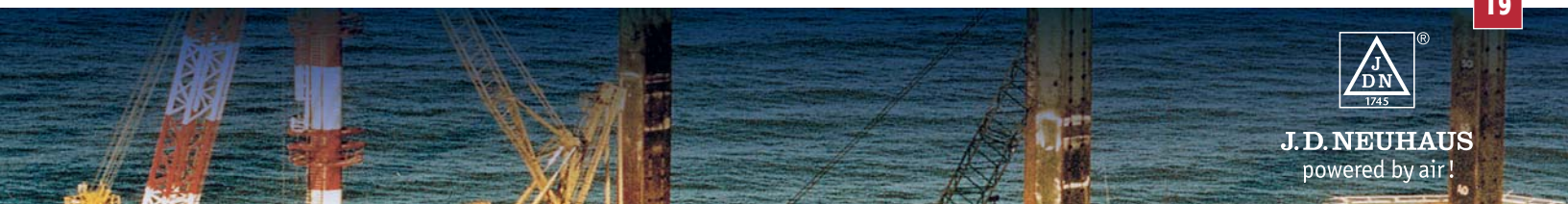

# JDN AIR WINCHES PROFI

## PROFI LIFTER 2600 / 4400 PROFI PULLER 4000 / 6600

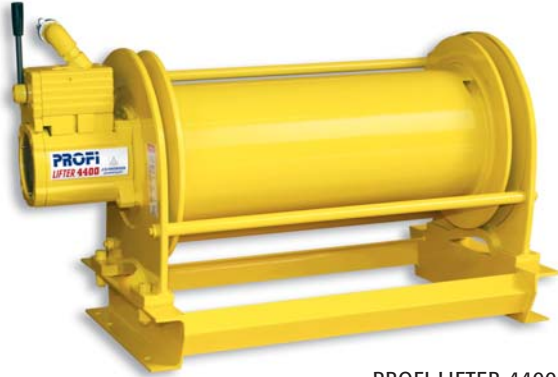

PROFI LIFTER 4400  
with long drum\*  
and mounting frame\*



PROFI PULLER 6600  
long drum\* version with  
a free-spooling clutch\*

### DIMENSIONS

inch.	PROFI LIFTER 2600 PROFI PULLER 4000		PROFI LIFTER 4400 PROFI PULLER 6600	
	Short drum	Long drum	Short drum	Long drum
B <sub>1</sub>	15.5		18.7	
H <sub>1</sub> max.	21.3		23.2	
L <sub>1</sub> max.	23.0	30.9	27.6	43.3
L <sub>2</sub>	8.5	16.4	12.0	27.8
D <sub>1</sub>	9.5		11.2	
D <sub>2</sub>	13.8		16.9	
A <sub>1</sub>	11.6		13.4	
A <sub>2</sub>	12.3	20.2	17.7	33.4

\*Option

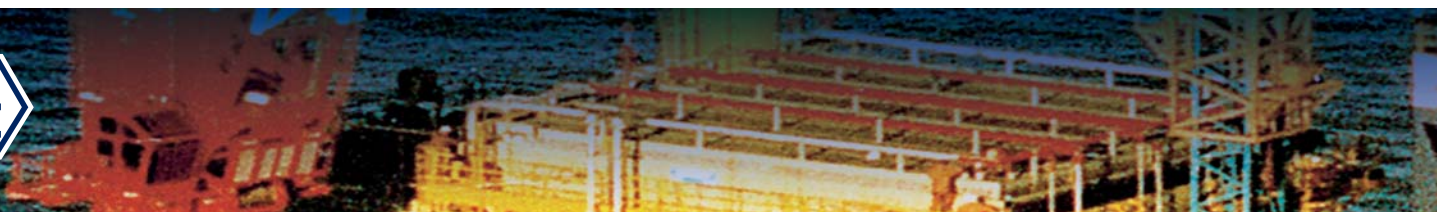
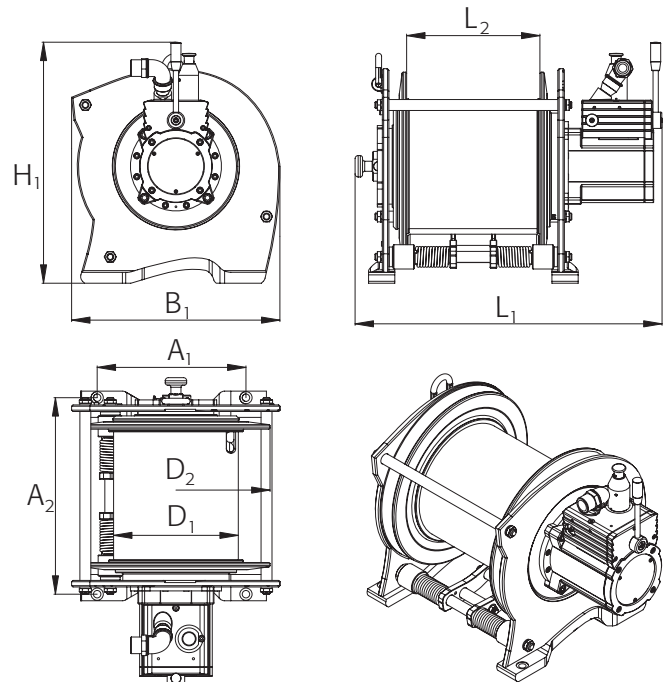

## ROPE CAPACITIES

PROFI LIFTER 2600 and PROFIL PULLER 4000				
Short drum				
Full used rope layer	Rope diameter			
	inch.	5/16	3/8	7/16
1st	ft	57.8	47.2	40.5
1st and 2nd	ft	131.3	109.6	95.7
1st, 2nd and 3rd	ft	209.2	176.3	155.4
1st, 2nd, 3rd and 4th	ft	291.6	247.6	219.6

PROFI LIFTER 2600 and PROFIL PULLER 4000				
Long drum				
Full used rope layer	Rope diameter			
	inch.	5/16	3/8	7/16
1st	ft	121.7	100.8	87.5
1st and 2nd	ft	263.2	220.9	193.9
1st, 2nd and 3rd	ft	413.3	349.5	308.9
1st, 2nd, 3rd and 4th	ft	574.9	486.7	432.5

Recommended rope diameter: 3/8"

PROFI LIFTER 4400 and PROFIL PULLER 6600				
Short drum				
Full used rope layer	Rope diameter			
	inch.	3/8	7/16	1/2
1st	ft	83.2	70.4	60.8
1st and 2nd	ft	152.7	159.6	140.0
1st, 2nd and 3rd	ft	294.4	255.0	225.4
1st, 2nd, 3rd and 4th	ft	409.3	356.0	317.1

PROFI LIFTER 4400 and PROFIL PULLER 6600				
Long drum				
Full used rope layer	Rope diameter			
	inch.	3/8	7/16	1/2
1st	ft	209.8	179.5	156.7
1st and 2nd	ft	447.0	385.9	340.1
1st, 2nd and 3rd	ft	698.7	606.8	537.9
1st, 2nd, 3rd and 4th	ft	964.9	842.2	750.3

Recommended rope diameter: 1/2"

Note: The calculated possible rope storage capacities depending upon the rope diameter and rope layers used are listed in the tables. The retention of the required three safety windings was also taken into account.

## CHARACTERISTIC LOAD CURVES

### PROFI LIFTER 2600 and PROFIL PULLER 4000

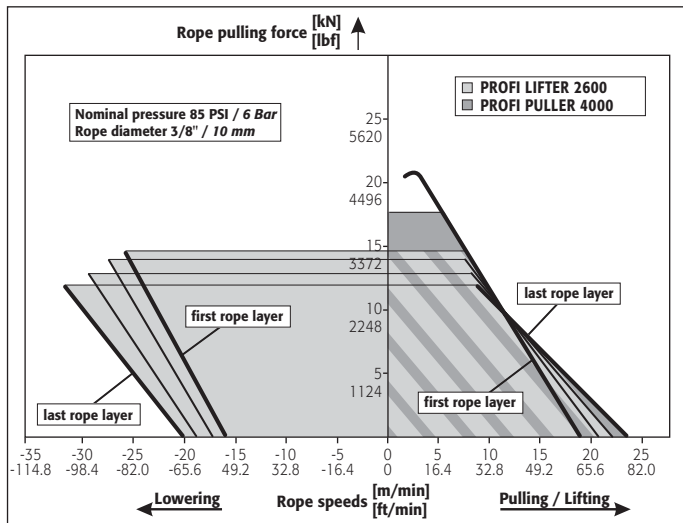

### PROFI LIFTER 4400 and PROFIL PULLER 6600

