

# JDN MONORAIL AIR HOISTS

## Specialized Lifting Systems for Large Capacity Loads Offshore, Underground, Anywhere From 10 Ton to 100 Ton Capacity Air Pressure 85 PSI (6 Bar)

Monorail Hoists EH are special high capacity lifting systems designed to handle heavy loads. Because of the trolley wheel design, they can be used on standard I-beams either with tapered or parallel flanges, or on special fabricated beams. **JDN Monorail Hoists** are especially suited for applications in high humidity, dust or hazardous environments with a high risk of explosion.

### FEATURES

#### Explosion-proof

- Low headroom
- Small size relative to capacity
- Little air consumption
- High performance multi-vane motor with self-lubricating features and positive start-up system for a smooth start and consistent operation
- Trolleys with anti-drop and anti-climb devices
- All-steel cast iron construction
- Silencer for low noise operation

### OPTIONS

- Spark-resistant package
- Rack and pinion drive
- Offshore paint
- Delta-P overload protection

### APPLICATIONS

- Power generation: Turbine, generator maintenance.
- Cement industry: Roller pair handling in roller mills.
- Offshore oil industry: Riser/pipe handling in riser bridge cranes; service units in generator stations.
- Foundries: Hoisting systems in high capacity foundry cranes.
- Pipelines: Valve replacement in pipeline pump.
- Chemical industry: Handling of reactor sections.

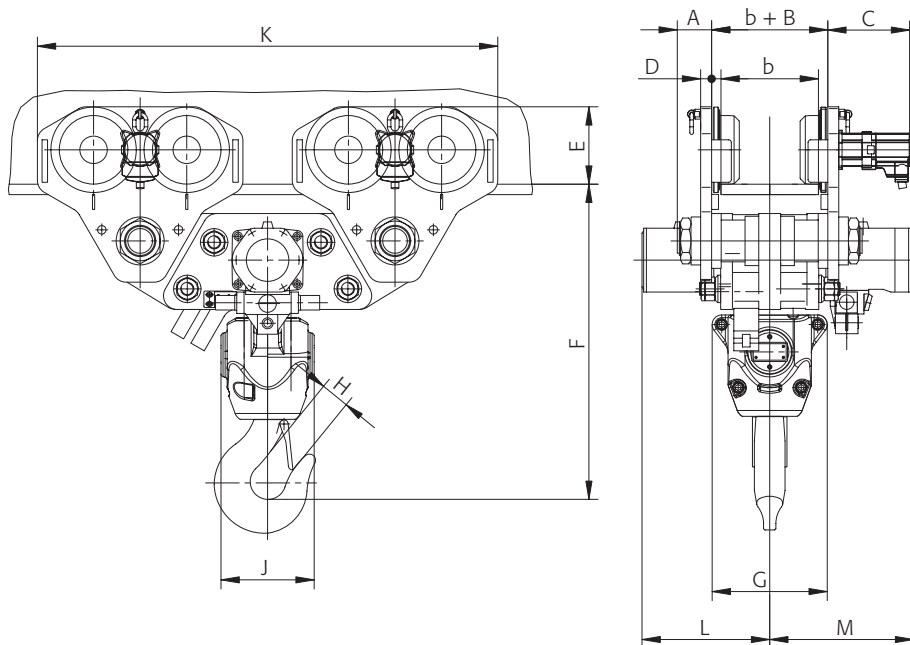

### DIMENSIONS

Type		EH 10	EH 16	EH 20	EH 25	EH 37	EH 50	EH 75	EH 100
A max.	inch. mm	4.1 105	5.1 130	5.1 130	5.8 146	3.9 100	4.9 125	3.9 100	4.9 125
B	inch. mm	2.8 70	2.7 68	2.7 68	2.8 70	2.7 68	2.7 68	2.7 68	2.7 68
C	inch. mm	11.2 285	11.6 295	11.6 295	11.2 285	11.6 295	11.8 300	11.6 295	11.8 300
D	inch. mm	0.9 25	1.4 35	1.4 35	1.0 25	1.4 35	1.6 40	1.4 35	1.6 40
E	inch. mm	7.8 198	8.7 220	8.7 220	7.8 198	8.7 220	11.1 283	8.7 220	11.1 283
F*	inch. mm	27.8 705	29.5 750	32.3 820	39.3 998	42.1 1070	45.3 1150	58.3 1480	60.4 1535
G	inch. mm	5.4 138	8.4 213	7.9 200	6.7 170	7.5 190	16.5 420	11.3 286	22.6 575
H	inch. mm	1.7 44	2 53	3 75	3 75	3.9 100	3.9 100	4.7 120	4.7 120
J	inch. mm	7.6 192	7.3 185	10.5 266	13.8 350	17.9 455	13.4 340	29.1 740	18.5 470
K	inch. mm	22.8 580	23.6 600	23.6 600	46.7 1185	68.1 1730	66.1 1680	126.1 3210	123.2 3130
L	inch. mm	12.1 308	14.5 367	14.5 367	14.8 377	14.8 377	18.2 462	25.2 640	30 762
M	inch. mm	10.5 266	12.8 325	12.8 325	17.1 435	17.1 435	22.1 560	25.8 655	29.5 750

\*Chain containers increase the headroom





EH 20



EH 50



EH 100

**TECHNICAL DATA**

Type		EH 10	EH 16	EH 20	EH 25	EH 37	EH 50	EH 75	EH 100
Carrying capacity	mt	10	16	20	25	37.5	50	75	100
Number of chain strands		2	3	4	2	3	4	3	4
Motor output Trolley	kW	0.7	0.7	0.7	1.4	1.4	1.4	2.8	2.8
Motor output Hoist	kW	3.5	3.5	3.5	6	6	6	10	10
Air pressure	PSI	85	85	85	85	85	85	85	85
	Bar	6	6	6	6	6	6	6	6
Lifting speed at full load	ft/m	5.3	3.3	2.3	3.6	2.1	1.6	1.5	1.2
	m/min	1.6	1	0.7	1.1	0.6	0.5	0.5	0.4
Lifting speed without load	ft/m	10.5	6.6	4.6	7.6	5.3	3.6	2.8	2.1
	m/min	3.2	2	1.4	2.3	1.6	1.1	0.6	0.7
Lowering speed at full load	ft/m	11.2	6.9	5.3	6.2	4.9	3	3.3	2.5
	m/min	3.4	2.1	1.6	1.9	1.5	0.9	1.0	0.8
Travelling speed at full load	ft/m	39.4	39.4	39.4	39.4	39.4	39.4	39.4	39.4
	m/min	12	12	12	12	12	12	12	12
Travelling speed without load	ft/m	44.3	44.3	44.3	44.3	44.3	44.3	44.3	44.3
	m/min	13.5	13.5	13.5	13.5	13.5	13.5	13.5	13.5
Air consumption – Trolley	cfm	46	46	46	92	92	92	184	184
	m <sup>3</sup> /min	1.3	1.3	1.3	2.6	2.6	2.6	5.2	5.2
Air consumption – Hoist	cfm	113.2	113.2	141.5	194.6	194.6	194.6	389.1	389.1
	m <sup>3</sup> /min	3.2	3.2	4	5.5	5.5	5.5	11	11
Air connection		G <sup>3</sup> / <sub>4</sub>	G <sup>3</sup> / <sub>4</sub>	G <sup>3</sup> / <sub>4</sub>	G1 <sup>1</sup> / <sub>2</sub>	G1 <sup>1</sup> / <sub>2</sub>	G1 <sup>1</sup> / <sub>2</sub>	G1 <sup>1</sup> / <sub>2</sub>	G1 <sup>1</sup> / <sub>2</sub>
Hose dimension	inch.	0.8/1.2	0.8/1.2	0.8/1.2	1.4/2	1.4/2	1.4/2	1.4/2	1.4/2
(Ø inside/Ø outside)	mm	19/31	19/31	19/31	35/31	35/31	35/31	35/31	35/31
Weight with standard lift	lbs	992.1	1267.7	1366.3	2093.5	3195.3	3922.5	8814.7	12560.9
	kg	450	575	620	950	1450	1780	4000	5700
Chain dimension	inch.	0.6 x 1.8	0.6 x 1.8	0.6 x 1.8	0.9 x 2.6	0.9 x 2.6	0.9 x 2.6	1.2 x 3.5	1.2 x 3.5
	mm	16 x 45	16 x 45	16 x 45	23.5 x 66	23.5 x 66	23.5 x 66	31.5 x 90	31.5 x 90
Weight of 1 m chain	lbs	12.8	12.8	12.8	26.9	6.9	6.9	46.9	46.9
	kg	5.8	5.8	5.8	12.2	12.2	12.2	21.3	21.3
Standard lift	ft	10	10	10	10	10	10	10	10
	m	3	3	3	3	3	3	3	3
Length of control at standard lift	ft	6.5	6.5	6.5	6.5	6.5	6.5	6.5	6.5
	m	2	2	2	2	2	2	2	2
Sound level at full load <sup>1</sup> with standard silencer – lifting	dB(A)	78	78	80	83	83	83	88	88
Sound level at full load <sup>1</sup> with standard silencer – lowering	dB(A)	80	80	84	83	83	83	89	89

<sup>1</sup> Measured at 1 m distance acc. to DIN 45635 part 20

