

PARTS AND MAINTENANCE MANUAL FOR PALAIR PLUS AIR CHAIN HOIST MODELS

With standard load chain:

PAL1001K and PAL2000K

With stainless steel load chain (x):

PAL800K and PAL1600K

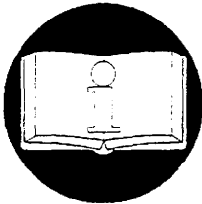

READ THIS MANUAL BEFORE USING THESE PRODUCTS. This manual contains important maintenance information. Make this manual available to all persons responsible for the maintenance of these products.

⚠ WARNING

Do not use this hoist for lifting, supporting, or transporting people or lifting or supporting loads over people.

Always operate, inspect and maintain this hoist in accordance with European Security Rules and any other applicable safety codes and regulations.

Refer all communications to the nearest INGERSOLL-RAND Material Handling Products Office or Distributor.

Form SAM0090
Edition 3
January 1997
96340061
©1997 INGERSOLL-RAND

INGERSOLL-RAND
MATERIAL HANDLING

TABLE OF CONTENTS

Description	Page N°.
Maintenance	
Maintenance Intervals.....	3
General Disassembly	4
Disassembly Instructions.....	4
Air Gear Motors disassembly.....	5
Pendants Control disassembly.....	5
Cleaning, Inspection and Repair.....	5
Assembly Instructions.....	6
Air Gear Motors Assembly.....	7
Pendants Control Assembly.....	7
Pendant Control Adjustment.....	7
Parts	
Motor Assembly Drawing.....	8
Motor Assembly Parts List	9
Motor with emergency stop valve Assembly Drawing.....	10
Motor with emergency stop valve Assembly Part List.....	11
Motor with overload and emergency stop valve Assembly Drawing.....	12
Motor with overload and emergency stop valve Assembly Part List.....	13
Hoist Assembly Drawing.....	14
Hoist Assembly Parts List.....	15
Hook Assembly Drawing.....	16
Hook Assembly Parts List.....	17
PHS2 Remote Control Assembly Drawing.....	18
PHS2 Remote Control Assembly Parts List.....	19
PHS2U Remote Control with Emergency Stop Assembly Drawing.....	20
PHS2U Remote Control with Emergency Stop Assembly Parts List.....	21
Chain bucket Assembly Drawing and Part List.....	22
Parts Ordering Information	
Warranty.....	23
Office Location	24

WARNING

- Never perform maintenance on the Hoist while it is supporting a load.
- Before performing maintenance, tag controls : **DANGER - DO NOT OPERATE - EQUIPMENT BEING REPAIRED.**
- Only allow service personnel trained in the operation and service of this hoist to perform maintenance.
- After performing any maintenance on the hoist, test hoist to 125% of its rated capacity before returning to service.
- Turn off air system and depressurize air lines before performing any maintenance.

INTERVAL	MAINTENANCE CHECKS
Start of each shift	Make a thorough visual inspection of the hoist for damage. Do not operate the hoist if damage found. Check the operation of the brake.
6 Months	Inspect the disc brake friction linings. Clean or replace parts as required. Lubricate brake spring washers.
Annually	Inspect the gearing, shafts, and bearings for damage or wear. Check all of the supporting members, including the trolley if used.

Disk Brake Adjustment

No brake adjustment is required.

NOTICE

- When any part of the brake disc thickness measures 0.098 in. (2.5 mm) or less, brake disc must be replaced.

Brake Disc Replacement

To check or replace the brake friction disc (83) use the following procedure.

1. Loosen capscrews (78) one turn at a time progressively round the cover (77) until brake spring load is relaxed. Remove capscrews (78) holding cover to the brake cover (73).
2. Remove cover (77), spring washers (80) and brake disc (79).
3. Pull brake friction disc (83) from pinion (112).
4. Replace brake friction disc (83) so spline locates on pinion (112).
5. Install brake disc (79). Place spring washers (80) on brake disc starting with a dished surface toward the brake disc. Alternate spring washers (80) (dished up/dished down).
6. Align pin (82) in brake disc (79) with hole in cover (77) then install cover (77) and pull down evenly with capscrews (78).

CAUTION

- The brake will not operate properly if there is oil or grease on the brake disc.

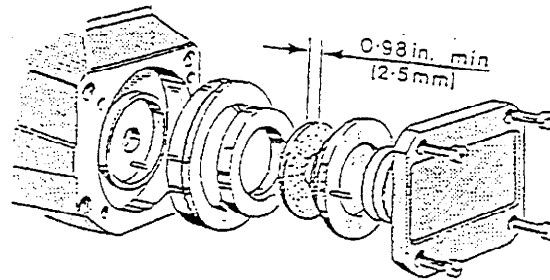

(Dwg. D6090011)

Chain Replacement

(Ref. Dwg. D6090009)

1. The hoist must be hung and connected to the air supply. Reduce air pressure to 60 psi (4 bar).
2. Remove chain bucket, if used.
3. Remove free end of chain from hoist body "A", if attached. Remove chain stop buffer (133).
4. Run hoist slowly in the lifting direction until the chain free end is approximately 2 ft (60 cm) from the hoist.

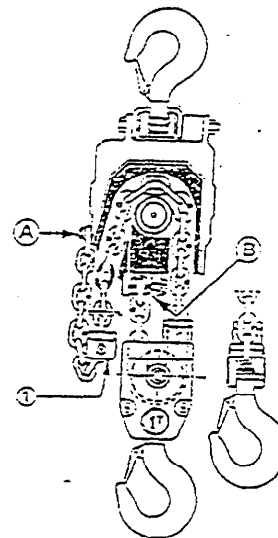

(Dwg. D6090009)

5. Using a 'C' link which is the same size as the chain join the new chain to the old taking care that the weld on the "standing" links on the new chain are facing away from the hoist load sheave.
6. Run the hoist slowly until the new chain has passed 24 to 36 in. (60 to 90 cm) through the hoist.
7. Install buffer (133) on the hook fall of the load chain. The offset shoulder of the buffer (133) must be toward the hose connection end of the hoist. The buffer actuates the top limit switch.

Single chain fall hoists.

8. Remove retainer wire (130), hook ring (129) and hook anchor pin (128). Position the last link of the chain in the hook slot. Replace hook anchor pin (128), hook ring (129) and retainer wire (130).
9. Install buffer (133) on opposite chain end so offset shoulder of buffer is facing the bottom of the hoist motor. Place buffer 6 in. (15 cm) from the chain end. This buffer activates the bottom limit switch.
10. Secure buffer (133) in position with capscrew (137) and nut (136).
11. Attach the last chain link to the hoist with capscrew (115) and washer (114).

CAUTION

- Check that the chain is not twisted.

Double chain fall hoists

12. Feed the chain end with a nylon string into the bottom block (127). Take care that the "standing" links on the new chain are facing away from the hook block sheave.
13. Secure the last link of the chain to the hoist body with capscrew (101) and nut (56).

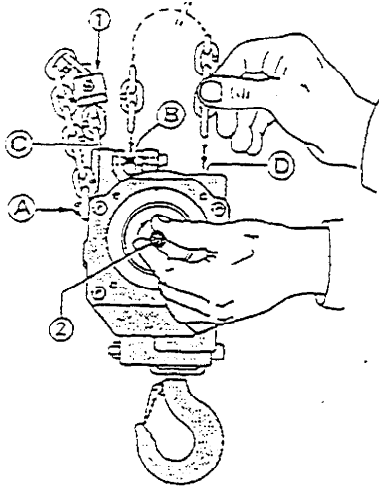

Dwg. D6090010)

14. Secure the opposite end of the chain as previously described for the single chain fall hoists.
- In the event that the chain has been completely removed from the hoist it will be necessary to remove the hoist brake. Refer to the instructions for "Brake Disc Replacement" (Ref. Dwg. D6090010).
- Insert the first link in "D" so link is parallel to pinion (112). Ensure welded side of second chain link faces away from sprocket (107). Rotate pinion (112) by hand to install chain until it appears at "C".

CAUTION

- Do not attempt to install the chain by powering the hoist.

Attach the chain at "A" after installing buffer (133). Reinstall the brake and complete chain installation as previously described.

General Disassembly

The following instructions provide the necessary information to disassemble, inspect, repair, and assemble the hoist. Parts drawings of the hoist assembly are provided in the Parts Section.

If a hoist is being completely disassembled for any reason, follow the order of the topics as they are presented.

It is recommended that all maintenance work on the hoist be performed on a bench in a clean dust free work area. In the process of disassembling the hoist, observe the following:

1. Never disassemble the hoist any further than is necessary to accomplish the needed repair. A good part can be damaged during the course of disassembly.
2. Never use excessive force when removing parts. Tapping gently around the perimeter of a cover or housing with a soft hammer, for example, is sufficient to break the seal.
3. Do not heat a part with a flame to free it for removal, unless the part being heated is already worn or damaged beyond repair and no additional damage will occur to other parts.
In general, the hoist is designed to permit easy disassembly and assembly. The use of heat or excessive force should not be required.
4. Keep the work area as clean as practical, to prevent dirt and other foreign matter from getting into bearings or other moving parts.
5. All seals and 'O' rings should be discarded once they have been removed. New seals and 'O' rings should be used when assembling the hoist.
6. When grasping a part in a vise, always use leather-covered or copper-covered vise jaws to protect the surface of the part and help prevent distortion. This is particularly true of threaded members, machined surfaces and housings.
7. Do not remove any part which is press fit in or on a subassembly unless the removal of that part is necessary for repairs or replacement.

Disassembly Instructions

(Ref. Dwg. D6340007)

1. Disconnect all hoses from hoist motor. Position hoist vertically so brake end is down. Remove capscrews (33) and pry motor assembly from gear casing (61). Set motor assembly to one side for later disassembly. Pull coupling (110) from pinion (112).
2. Remove capscrews (6), pull out tubes (57) and screen (58) from gear casing (61). Reposition hoist in a vertical position so motor end is down.
3. Progressively loosen capscrews (78) in cover (77) one turn at a time each, until the brake spring load is relaxed.
4. Remove spring washers (80). Lift off brake disc (79) and brake friction disc (83).
5. Remove capscrews (116) and pry brake cover (73) and gasket (90) from gear casing (61). Lift off spring washer (88).
6. Pull piston (76) with 'O' rings (74) and (75) from brake cover (73).
7. Pry bearing (89) from planet carrier (64).
8. Set hoist in a horizontal position and from the motor end of the gear casing (61) carefully tap on the end of pinion (112) to remove planet assembly.
9. Remove retainer ring (85) and tap out pinion (112).

10. If planet assembly requires disassembly slide out planet axles (93) and separate planet gears (96), spacers (94) and needle bearings (92).
11. Remove ring gear (91) from gear casing.

NOTICE

- Check that load chain has been removed before attempting to remove sprocket (107).

12. Remove retainer ring (105) from the motor side and tap on sprocket from the brake end of gear casing (61) to drive out sprocket (107) and bearing (106).
13. Lift out ring gear (63) and bearing (62).
14. Tap out ball bearing (106) from the brake end of gear casing (61) to remove joint (60) from motor side.
15. Remove screw (97), slide out pin (100) and chain guide (98).
16. Remove shafts (56) from gear casing (61) and slide out chain guide (59).

Air Gear Motor Disassembly

(Ref. Dwg. D6340003)

Refer to disassembly instructions to remove motor assembly from gear casing.

1. Remove capscrews (8).
2. Remove the motor cover (11). If necessary, remove retainer rings (39) and bearings (41), 'O'rings (38) and pins (43).
3. Remove the motor housing (46), spring (9), slide valve (44), stop (36), side valve (10) and quad-ring (42-48).
4. Immobilize the motor rotors with a rod between the teeth and remove nuts (3).
5. Remove the motor rotors (7, 45).
6. Remove the screw (6) and the washer (5).
7. Remove ball bearing (4).

Motor with emergency stop valve Disassembly

(Ref. Dwg. D6340002)

Refer to disassembly instructions to remove motor assembly from gear casing.

Refer to Air gear motor disassembly instructions to remove motor.

For dismantling valve:

1. Remove screws (31).
2. Remove the cover (50) with the spring (52).
3. Remove 'O'ring (51) from the cover (50).
4. Remove screws (33-37-40).
5. Remove the cover (22).
6. Remove the diaphragm (24).
7. Immobilize the valve cone (25) by its hole with a rod in a orifice of the cover (11) and remove the screw (29).
8. Remove the valve cone (30-25) with the joint (26) and the distance ring (28) with the washer (27).

Motor with overload and emergency stop valve Disassembly

(Ref. Dwg. D6340001)

Refer to disassembly instructions to remove motor assembly from gear casing.

For dismantling overload valve:

1. Remove the screw (20) and the joint (19)

2. Remove screws (33-37-40).
3. Remove the cover (22).
4. Remove the valve cone assembly (18-16-21-17-2).
5. Remove the spring (23), the spring receiver (15) and the ball (14).
6. Remove the nut (12), the Usit-ring (13) and the screw (47).

PHS2 Pendant Control Disassembly

(Ref. Dwg. D6090018)

1. Remove the fittings (32) and the eyebolt (162).
2. Remove the retainer rings (173).
3. Pull out rear covers (172) with the 'O'ring (171).
4. Remove the springs (170).
5. Remove the slide valve (169) with the quad ring (168).
6. Remove the spring (167).
7. Remove the valve cone ass'y (166).
8. Remove the setscrew (164).
9. Tap out pin (165) to remove the levers (163).

PHS2U Pendant Control With Emergency Stop Disassembly

(Ref. Dwg. D6340012)

Refer to PHS2 Control Disassembly to begin PHS2U Disassembly

10. Remove the emergency button (188).
11. Remove the setscrews (185).
12. Remove the spools (187).
13. Pull out the shuttle valve stop (183) with ball (184).
14. Remove the 'O'ring (182) from shuttle valve stop (183) and spool (187).

Cleaning, Inspection and Repair

Use the following procedures to clean, inspect and repair the components of the hoist.

Cleaning



- Bearings that are loose, worn or rotate in the frame must be replaced. Failure to observe this precaution will result in additional component damage.
- Do not use trichloroethylene to clean parts.

Clean all hoist component parts in solvent (except for the brake disc). The use of a stiff bristle brush will facilitate the removal of accumulated dirt and sediments on the gears and frames. If bushings have been removed it may be necessary to carefully scrape old Loctite ® from the bearing bores. Dry each part using low pressure, filtered compressed air.

Inspection

All disassembled parts should be inspected to determine their fitness for continued use. Pay particular attention to the following :

1. Inspect all gears for worn, cracked, or broken teeth.
2. Inspect all bushings for wear, scoring, or galling.

3. Inspect shafts for ridges caused by wear. If ridges caused by wear are apparent on shafts, replace the shaft.
4. Inspect all threaded items and replace those having damaged threads.
5. Inspect the brake disc for oil and wipe clean as required. If the brake disc is glazed, sand it lightly using fine emery cloth.
6. Measure the thickness of the brake friction disc (83). If the brake disc is less than 0.098 in. (2.5 mm) replace it.
7. Check screen (58) and silencer (68) for damage or excessive dirt.

Repair

Actual repairs are limited to the removal of small burrs and other minor surface imperfections from gears and shafts. Use a fine stone or emery cloth for this work.

1. Worm or damaged parts must be replaced. Refer to the applicable Parts Listing for specific replacement parts information.
2. Inspect all remaining parts for evidence of damage. Replace or repair any part which is in questionable condition. The cost of the part is often minor in comparison with the cost of redoing the job.
3. Smooth out all nicks, burrs, or galled spots on shafts, bores, pins or bushings.
4. Examine all gear teeth carefully, and remove nicks or burrs.
5. Polish the edges of all shaft shoulders to remove small nicks which may have been caused during handling.
6. Remove all nicks and burrs caused by lockwashers.

Assembly instructions (Ref. Dwg. D6340007)

1. Tap bearing (106) and joint (60) from the motor side of gear casing (61). Extreme care is required during this operation to ensure bearing (106) remains square.
2. Install second bearing (106) on sprocket (107). Slide chain guide (59) into gear casing (61). Tap or press assembled sprocket (107) into gear casing (61) from the motor side.
3. Install retainer ring (105) at motor side.
4. Install shafts (56) in gear casing (61). Jiggle chain guide (59) to aid installation.
5. Position hoist vertically with the motor end down. Slide chain guide (98) into gear casing (61), install pins (100) in gear casing (61) and tighten screw (97) for secure pins (100). Lubricate and install 'O'ring (95) in the groove on the outside of ring gear (63). Install ring gear (63) on spline of sprocket (107). Install bearing (62) on sprocket (107).
6. Install load chain. Refer to chain installation procedures in the "MAINTENANCE" section.
7. Install pinion (112), bearing (87) and retainer rings (85) and (86) in planet carrier (64).

NOTICE

Maintenance of the planet gear assembly should be limited to general cleaning and greasing of the planet gears (96) and bearings (92). If the planet gear assembly was removed during hoist disassembly it will be necessary to line up the timing marks on the planet gears correctly.

9. Assemble planet assembly so planet gears (96) mesh with pinion (112). Position planet gears (96) so the 'O' marks engraved on the planet gears are in line. Ref. Dwg. D6310013.
10. Install assembled planet assembly with pinion (112) in gear casing (61).
11. Install ring gear (91) with notches outward.

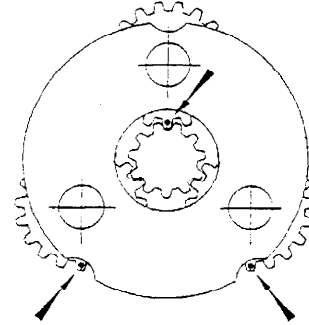

(Dwg. D6310013)

12. Install bearing (89) on planet carrier (64).
13. Install gasket (90) on brake cover (73). Place spring washer (88) on bearing (89) so dished side is toward the bearing (89). Lubricate gear casing. See "LUBRICATION" section.
14. Lubricate 'O'rings (69) and 'U' cup seal (84) and install in brake cover (73). The lip of 'U' cup seal (84) must be toward the planet assembly. Add Silicone seal to gear casing surface and install brake cover (73) so pins (81) line up. Exercise caution during this operation to ensure 'O'rings (69) remain in position. Secure brake cover (73) in position with capscrews (116).
15. Lubricate and install 'O'rings (74) and (75) on piston (76). Install piston (76) in brake cover (73).
16. Install brake disc (72) and brake friction disc (83).
17. Place brake disc (79) on brake friction disc (83). Install springs (80) on brake disc (79) starting with a dished surface toward the brake disc. Alternate springs (80) (dished up/dished down).
18. Align pin (82) in brake disc (79) with hole in cover (77) then install cover (77) and pull down evenly with capscrews (78).
19. Position hoist vertically with the brake end down. Set screen (58) in motor side of gear casing (61) and loosely secure with capscrews (6). Install tubes (57) through screen (58) until they are fully seated. Tighten capscrews (6). Install coupling (110) on pinion (112).
20. Install motor assembly (55) with 'O'ring (49) and secure with capscrews (33).
21. Install silencer (68) in gear casing (61) with capscrew (67).

Motor

If the motor assembly has been removed for disassembly, inspection or repair it is necessary that it be reassembled into casing (61) using a good quality silicone seal between the casing (61) and motor mounting flange. The silicone seal must be allowed to cure for 3 hours before attempting to pressurize the motor.

Air Gear Motor Assembly

(Ref. Dwg. D6340003)

1. Lubricate ball bearings (4) with grade 2 grease then install bearings in motor flange (1). Ensure markings on bearing cage are still visible after installation.
2. Install screw (6) and washer (5).
3. Install motor rotors (45-7) and retainer ring (39) with the part of the bearing (41).
4. Immobilize the motor rotors with a rod between the teeth and install nuts (3). Lightly coat nut threads with Loctite ® 234.
5. Install motor housing (46) with 'O'ring (2) on motor flange (1).
6. Install slide valve (44), springs (9), slide valve (10) with quad-ring (48), quad-rings (42) and 'O'ring (38) in motor housing (46) and stop in cover (11).
7. Install bearing (41) and stop (36) in motor cover (11). Install motor cover on motor housing (46). Ensure pins (43) are fully aligned and engaged. Secure with capscrews (8). Lightly coat capscrew threads with Loctite ® 234.

Air Gear Motor with emergency stop valve

(Ref. Dwg. D6340002)

Refer to air gear motor assembly instructions.

For mounting emergency stop valve:

1. Install the valve cone (30) with the joint (26), the washer (27) and the distance ring (28) on the screw (29), put the assembly in the cover (11).
2. Install and immobilize the valve cone (25) by its hole with a rod in a orifice of the cover (11) and secure the screw (29).
3. Install the diaphragm (24).
4. Install the cover (22) and secure with screws (33-37-40)
5. Install the cover (50) with the 'O'ring (51) and the spring (52). Secure with screws (31).

Air Gear Motor with overload and emergency stop valve.

(Ref. Dwg. D6340001)

Refer to air gear motor assembly instructions.

For mounting overload and emergency stop valve:

1. Install the valve cone (30) with the joint (26), the washer (27) and the distance ring (28) on the screw (29), put the assembly in the cover (11).
2. Install and immobilize the valve cone (25) by its hole with a rod in a orifice of the cover (11) and secure the screw (29).
3. Install the diaphragm (24).
4. Install the ball (14), the rececer spring (15) and the spring (23).
5. Install valve cone assembly (18-21-16-17-2)
6. Install the cover (22) and secure with screws (33-37-40).
7. Install the joint (19) and the screw (20) in the cover (22).
8. Install the cover (50) with the 'O'ring (51) and the spring (52). Secure with screws (31).
9. Install the screw (47), the Usit-ring (13) and the screw (47).

PHS2 Pendant Control Assembly

(Ref. Dwg. D6090018)

1. Install levers (163) in pendant handle with pin (165). Stake pin in pendant handle at both ends to secure.
2. Install setscrews (164).
3. Check that 'O'ring is undamaged and securely crimped in valve cone. Install valve cone assemblies (166).
4. Install springs (167).
5. Check that 'O'ring is undamaged and securely crimped in slide valves. Install quad ring (168) and slide valve ass'y (169).
6. Install springs (170).
7. Lubricate and install 'O'ring (171) on rear cover (172). Install rear cover in pendant handle.
8. Install retainer ring (173).

PHS2U Pendant Control With Emergency Stop Assembly

(Ref. Dwg. D6340012)

Refer to PHS2 control assembly to begin PHS2U assembly.

9. Install 'O'ring (182) on shultle valve stop (183) and spool (187).
10. Install that shultle valve stop (183) with ball (184); those spool (187) in the pendant handle (181) and secuse with setscrews (185).
11. Install the emergency bottom (188).
12. Install the eyebolt (162) and the fitting (32).

Pendant Control Adjustment :

1. Connect the inlet of the pendant to 100 psi (7 bar) air supply.
2. Connect a manometer at the outlet of the lever to be adjusted.
3. Apply a small amount of Loctite ® 243 on the adjustment setscrew (164).
4. Tighten the adjustment setscrew to obtain a pressure of 15 psi (1 bar) without actioning the lever.
5. Release the adjustment setscrew by a half turn (pressure must fall to zero).
6. Push the lever. Check that pressure reaches 93 +/- 7 psi (6.5 +/- 0.5 bar). Check that there is no leak at the exhaust.
7. Release the lever, exhaust must occur and result in rapid pressure reduction.
8. Repeat operations "9.6 and 9.7" from 2 to 3 times.
9. Disconnect the manometer. Check to ensure that there are no leaks when the lever is not activated.
10. Repeat the operations from 9.2 to 9.9 with each lever.

Hook Assemblies

If the hook assemblies have been disassembled for inspection or repair attention is required on reassembly to ensure that all ten balls (131) are installed and retained with washer (132) and hook ring (129).

MOTOR ASSEMBLY DRAWING

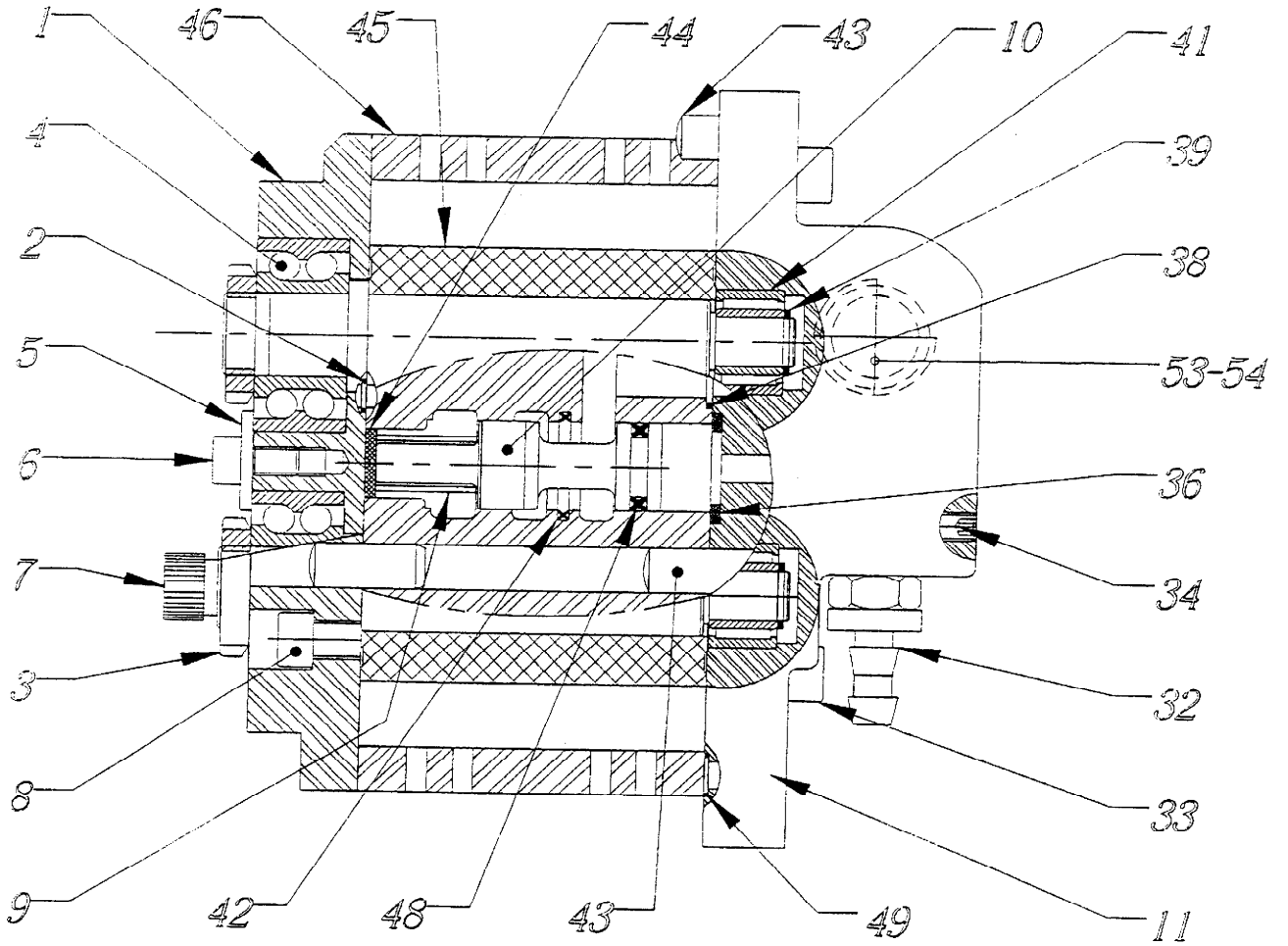

(Dwg: D6340003)

MOTOR ASSEMBLY PART LIST

ITEM NO.	DESCRIPTION OF PART	QTY TOTAL	PART NO.
1	Motor Flange	1	9609-0008
• 2	O Ring	2	5822-2329
3	Locknut	2	5700-0002
4	Ball Bearing	2	5060-0002
5	Washer	1	9609-0032
6	Screw	1	4130-6706
7	Driving Gear	1	9609-0031
8	Screw	4	4130-0806
9	Spring	2	9424-0224
10	Slide Valve	2	9424-0212
11	Motor Cover	1	9609-0079
32	Fitting	3	6165-2632
33	Screw	4	4132-2206
34	Screw	1	4200-7707
36	Stop	2	9609-0042
• 38	O Ring	2	5820-5029
39	Retainer Ring	2	4780-1339
41	Needle Bearing	2	5646-1912
• 42	Quad-ring	2	5823-1229
43	Pin	6	4600-0416
44	Slide Valve	2	9412-0030
45	Idle Gear	1	9609-0030
46	Motor Housing	1	9609-0007
• 48	Quad-ring	2	5822-8929
• 49	O Ring	2	5821-2229
53	Filter	1	6190-9028
• 54	Retainer Ring	1	4770-3018
55	Motor Ass'y (incl's item 1 through 54)	1	7609-0206

• Recommended Spare.

MOTOR WITH EMERGENCY STOP VALVE ASSEMBLY DRAWING

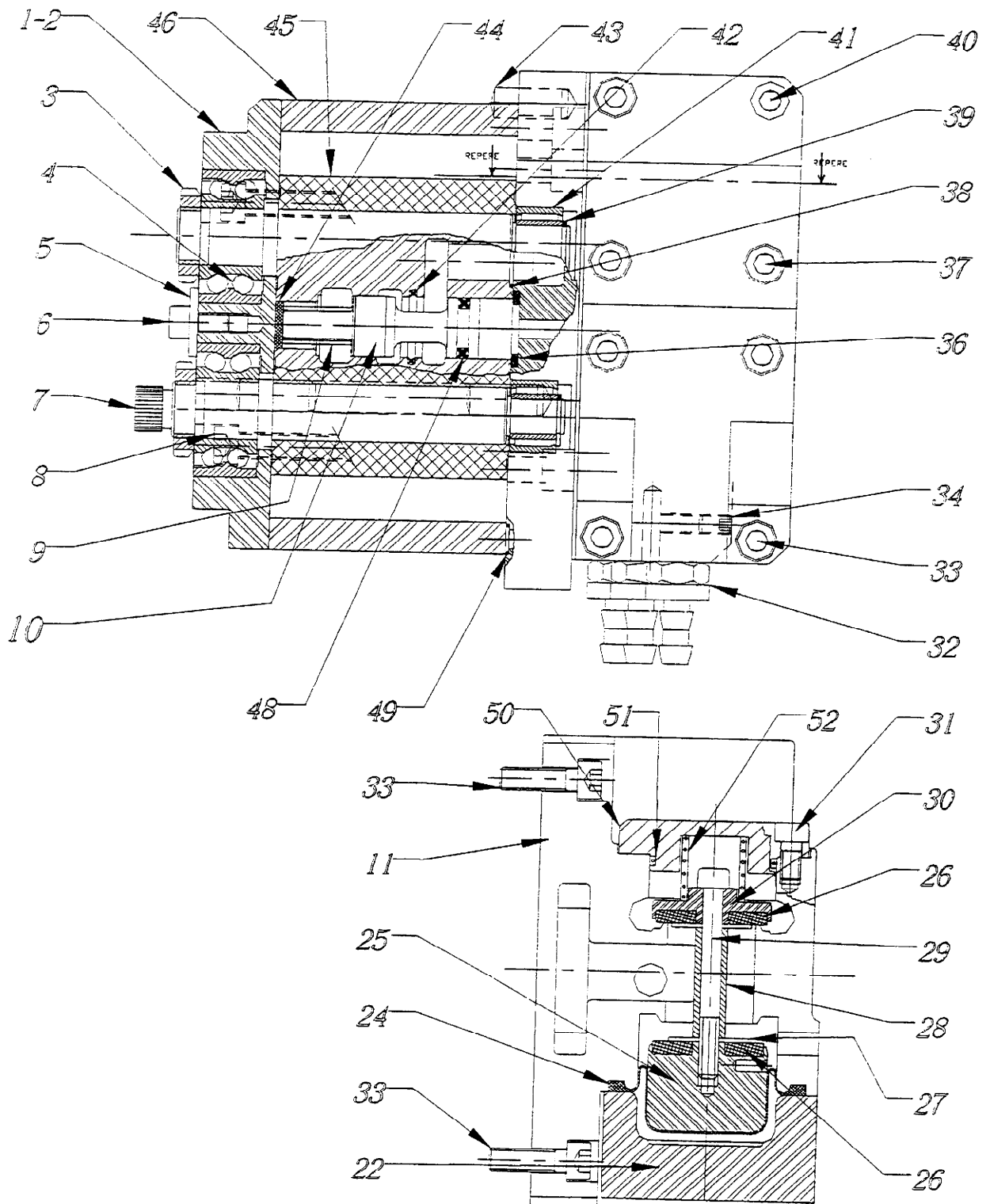

(Dwg: D6340002)

MOTOR WITH EMERGENCY STOP VALVE ASSEMBLY PART LIST

ITEM NO.	DESCRIPTION OF PART	QTY TOTAL	PART NO.
1	Motor Flange	1	9609-0008
• 2	'O' Ring	3	5822-2329
3	Locknut	2	5700-0002
4	Ball Bearing	2	5060-0002
5	Washer	1	9609-0032
6	Screw	1	4130-6706
7	Driving Gear	1	9609-0031
8	Screw	4	4130-0806
9	Spring	2	9424-0224
10	Slide Valve	2	9424-0212
11	Motor Cover	1	9609-0270
22	Cover	1	9609-0271
• 24	Diaphragm	1	6771-6341
25	Clapet	1	9617-0054
• 26	Joint	2	9617-0056
27	Washer	2	4570-0005
28	Spacer	2	9617-0055
29	Screw	1	4130-8206
30	Clapet	1	9617-0053
31	Screw	3	4132-6306
32	Fitting	5	6165-2632
33	Screw	6	4132-2206
34	Screw	1	4200-8307
36	Stop	2	9609-0042
37	Screw	4	4132-2306
• 38	'O' Ring	2	5820-5029
39	Retainer Ring	2	4780-1339
40	Screw	2	4132-4306
41	Needle Bearing	2	5646-1912
• 42	Quad-ring	2	5823-1229
43	Pin	6	4600-0416
44	Slide Valve	2	9412-0030
45	Idle Gear	1	9609-0030
46	Motor Housing	1	9609-0007
• 48	Quad-ring	2	5822-8929
• 49	'O' Ring	2	5821-2329
50	Cover	1	9617-0059
• 51	'O' Ring	1	5821-4829
52	Spring	1	6915-8732
55	Motor with emergency stop valve Ass'y (incl's item 1 through 52)	1	7609-0430

• Recommended Spare.

MOTOR WITH OVERLOAD AND EMERGENCY STOP VALVE ASSEMBLY DRAWING

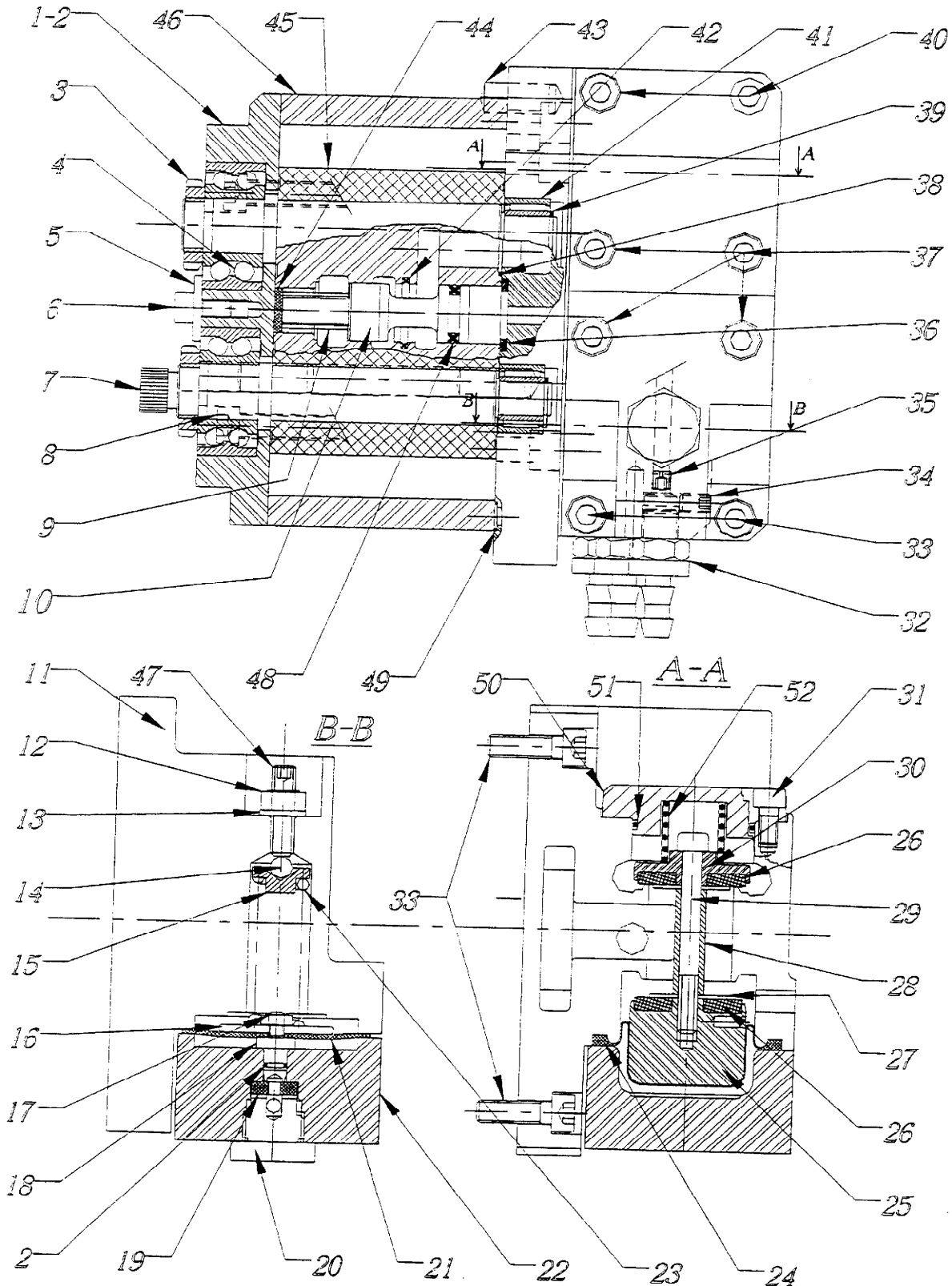

(Dwg. D6340001)

MOTOR WITH OVERLOAD AND EMERGENCY STOP VALVE ASSEMBLY PART LIST

ITEM NO.	DESCRIPTION OF PART	QTY TOTAL	PART NO.
1	Motor Flange	1	9609-0008
• 2	O' Ring	3	5822-2329
3	Locknut	2	5700-0002
4	Ball Bearing	2	5060-0002
5	Washer	1	9609-0032
6	Screw	1	4130-6706
7	Driving Gear	1	9609-0031
8	Screw	4	4130-0806
9	Spring	2	9424-0224
10	Slide Valve	2	9424-0212
11	Motor Cover	1	9609-0266
12	Nut Stop	1	4370-7611
13	Usit-ring	1	5840-4531
14	Ball	1	6940-0125
15	Spring Receiver	1	9636-0023
16	Washer	1	9636-0019
17	Nut	1	4300-1111
18	Clapet	1	9636-0017
• 19	Joint	1	9636-0021
20	Screw	1	9609-0269
21	Diaphram	1	9636-0020
22	Cover	1	9609-0267
23	Spring	1	6915-9432
• 24	Diaphram	1	6771-6341
25	Clapet	1	9617-0054
• 26	Joint	2	9617-0056
27	Washer	2	4570-0005

ITEM NO.	DESCRIPTION OF PART	QTY TOTAL	PART NO.
28	Spacer	1	9617-0055
29	Screw	1	4130-8206
30	Clapet	1	9617-0053
31	Screw	3	4132-6306
32	Fitting	5	6165-2632
33	Screw	6	4132-2206
34	Screw	1	4200-8307
35	Nozzle	1	9617-0071
36	Stop	2	9609-0042
37	Screw	4	4132-2306
• 38	O' Ring	2	5820-5029
39	Retainer Ring	2	4780-1339
40	Screw	2	4132-4306
41	Needle Bearing	2	5646-1912
• 42	Quad-ring	2	5823-1229
43	Pin	6	4600-0416
44	Slide Valve	2	9412-0030
45	Idle Gear	1	9609-0030
46	Motor Housing	1	9609-0007
47	Screw	1	4200-7107
• 48	Quad-ring	2	5822-8929
• 49	O' Ring	2	5821-2229
50	Cover	1	9617-0059
• 51	O' Ring	1	5821-4829
52	Spring	1	6915-8732
55	Motor with overload and	1	7609-0249
*	emergency stop valve ass'y		

• Recommended Spare.

HOIST ASSEMBLY DRAWING

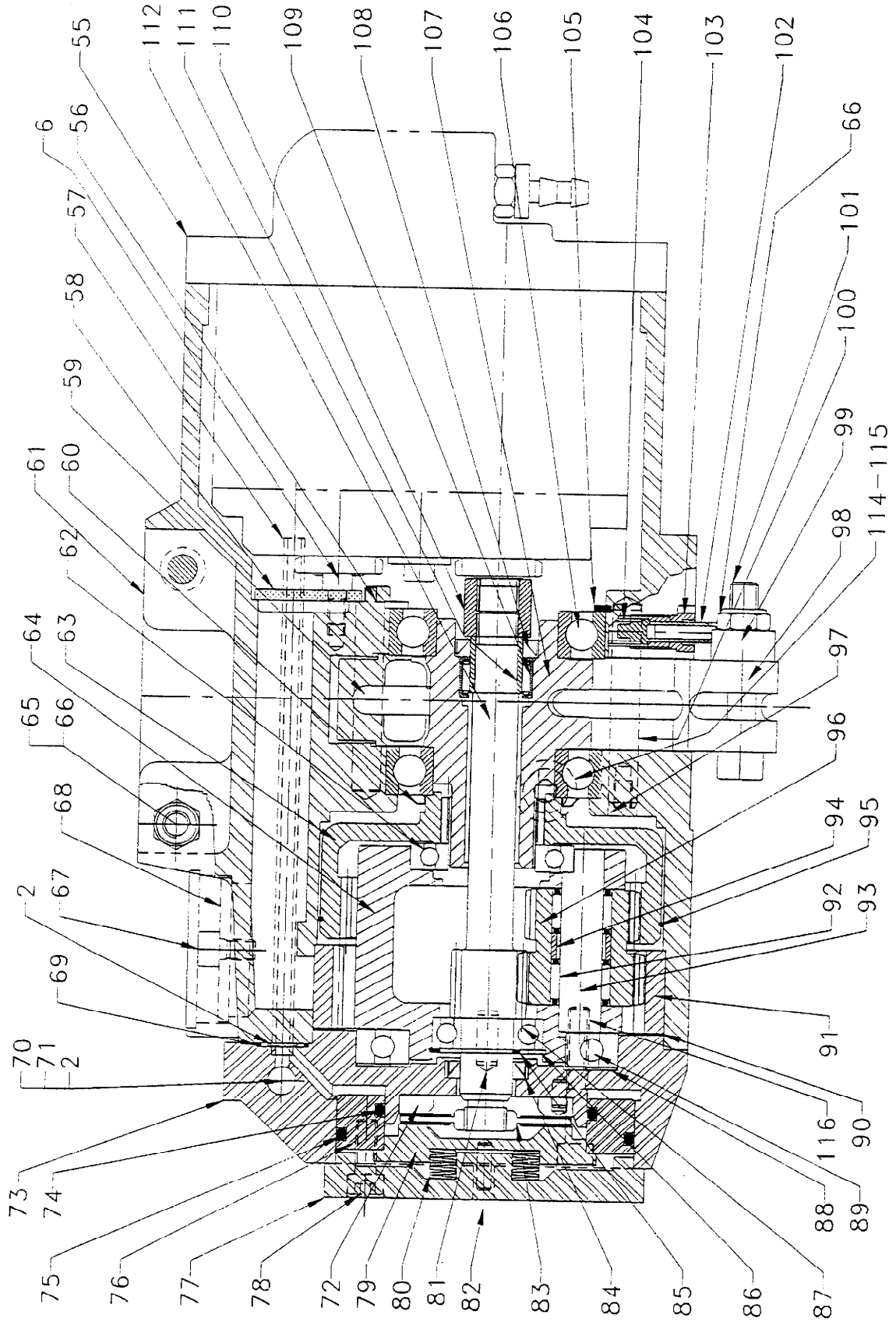

(Dwg. D6340007)

HOIST ASSEMBLY PART LIST

ITEM NO.	DESCRIPTION OF PART	QTY TOTAL	PART NO.
* 2	O Ring	4	5821-2229
6	Screw	2	4130-6706
33	Screw (incl's in item 55)	4	4132-2206
55	Motor	1	7609-0206
	With emergency stop valve	1	7609-0430
	With overload and stop valve	1	7609-0429
56	Idle gear	2	9609-0040
57	Tube	2	9609-0055
* 58	Screen	1	9634-0027
59	Chain guide	1	9634-0023
* 60	Front	1	5831-4007
61	Casing	1	9634-0005
62	Bearing	1	5080-0005
63	Ring gear	1	9618-0044
64	Planet carrier	1	9618-0041
65	Screw	2	4131-9606
66	Nut	3	4370-2311
67	Vis CHC	1	4130-0106
* 68	Silencer	1	9609-0056
* 69	O Ring	1	5822-1729
70	Shuttle valve stop	1	9609-0223
71	Ball	1	6940-1625
* 72	Brake disc	1	9609-0047
73	Brake cover	1	9609-0226
* 74	O Ring	1	5823-2229
* 75	O Ring	1	5823-2329
76	Piston	1	9609-0113
77	Cover	1	9609-0005
78	Screw	4	4130-0206
* 79	Brake disc	1	9609-0046
80	Spring washer	7	6916-0532
81	Pin	1	4600-1716
82	Pin	1	4640-6118

ITEM NO.	DESCRIPTION OF PART	QTY TOTAL	PART NO.
* 83	Brake friction disc	1	9609-0049
* 84	Quad-ring	1	5801-9830
85	Retainer Ring	1	4770-0015
86	Retainer Ring	1	4770-3032
87	Ball Bearing	1	5000-0002
88	Spring washer	1	6916-0432
89	Ball Bearing	1	5080-0009
90	Gasket	1	9609-0041
91	Ring gear	1	9609-0038
92	Bearing	6	5650-1713
93	Planet Pin	3	9609-0039
94	Spacer	3	9609-0026
* 95	O Ring	1	5821-2629
96	Planet gear	3	9618-0045
97	Screw	2	4120-1204
98	Chain guide	1	9634-0024
99	Spacer	1	9634-0020
100	Pin	2	4600-2116
101	Screw	1	4130-1806
102	Limit switch	2	9609-0051
* 103	Limit switch body	2	9609-0050
104	Spring	2	6916-0332
105	Retainer ring	1	4770-3062
106	Bearing	2	5005-0007
107	Sprocket	1	9634-0001
* 108	Quad-ring	1	5801-9830
109	Bearing	1	5632-1512
110	Coupling	1	9609-0034
111	Bearing	1	5636-2432
112	Pinion	1	9609-0035
114	Washer	1	4500-0108
115	Screw	1	4131-3006
116	Screw	4	4131-4906

Hoist Assembly with Option "R".

Substitute or add the following parts on hoist with option "R"

66	Screw	3	43707011
78	Screw	4	41322606
101	Screw	1	41326406

114	Washer	1	45001108
116	Screw	4	41327406

* Recommended Spare.

HOOK ASSEMBLY DRAWING

**PAL1600K & PAL2000K
Top Hook Assembly**

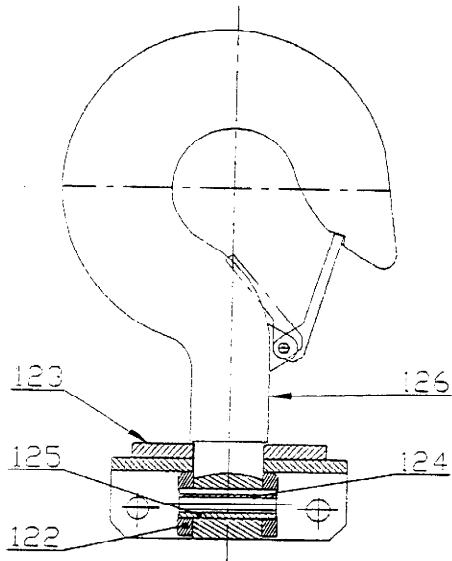

**PAL800K & PAL1001K
Top Hook Assembly**

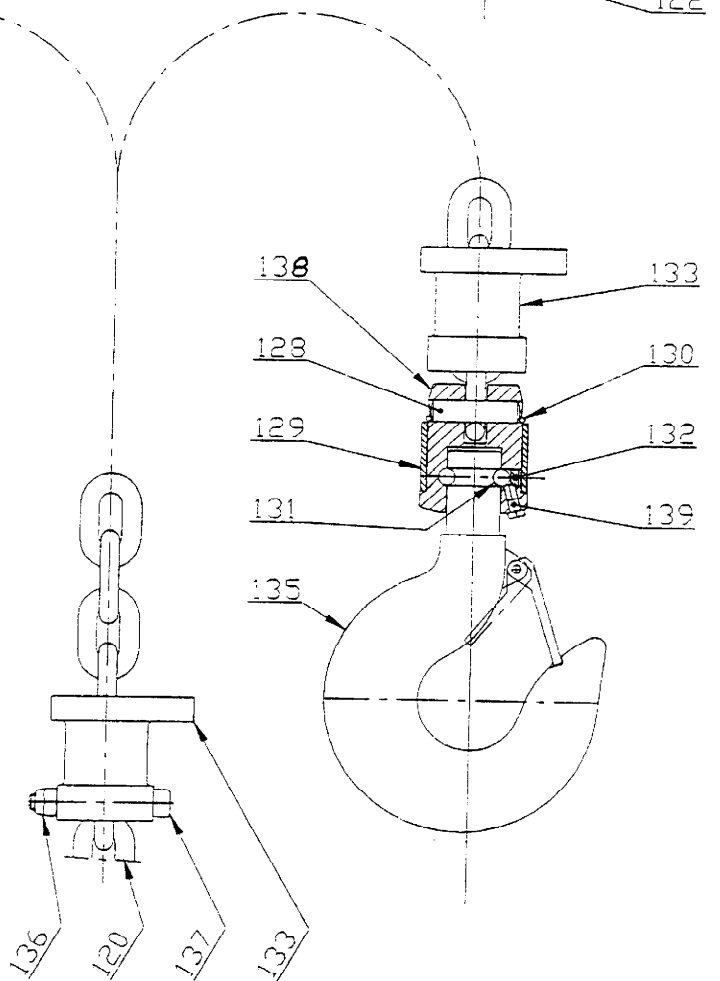
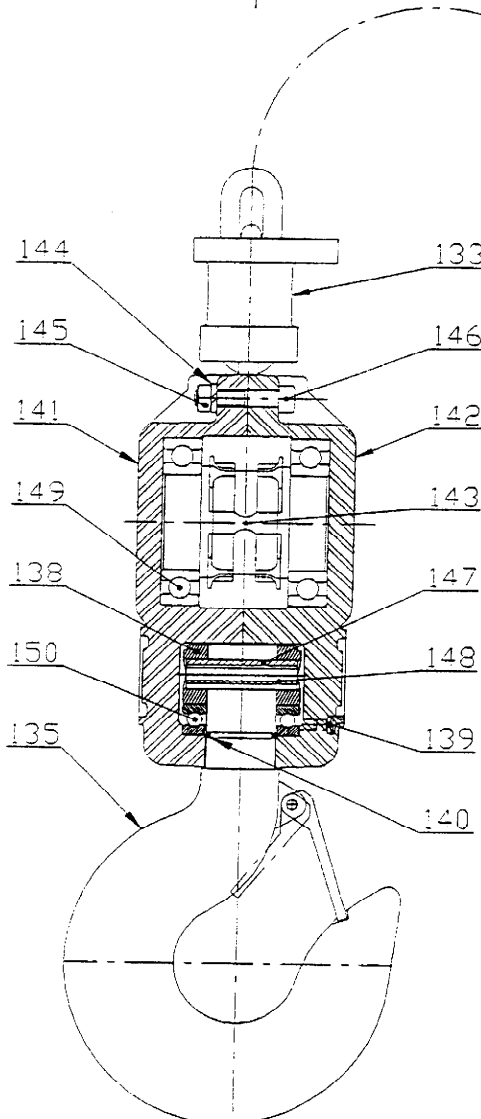
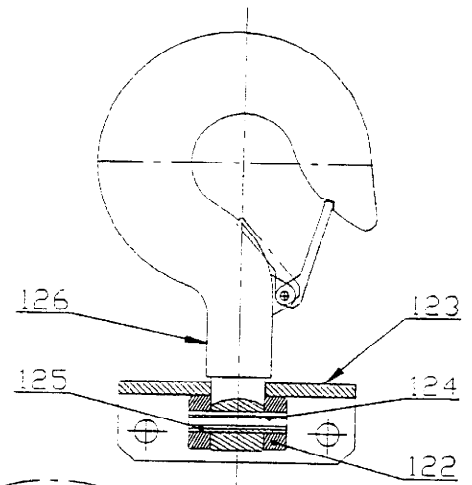

**PAL800K & PAL1001K
Bottom Hook Assembly**

**PAL1600K & PAL2000K
Bottom Hook Assembly**

(Dwg.D6340008)

HOOK ASSEMBLY PARTS LIST

ITEM NO.	DESCRIPTION OF PART	QTY TOTAL	PART NO.			
			0,98T to 1T (1 fall)		2T	
			standard	option "R"	standard	option "R"
120	Zinc Plated Load Chain (Std) Corrosion Treated load chain (Opt.N)	(meter)	6902-6841 6902-6941			
121	Top hook Assembly (incl's items 122 through 126)	1	7634-0005	7634-0033	7634-0035	7634-0034
122	Hook Ring	1	9634-0003	9634-0060	9634-0015	9634-0053
123	Support Plate	1	9609-0022	9609-0141	9634-0016	9634-0054
124	Roll Pin	1	4650-1020		4650-7820	
125	Roll Pin	1	4650-7720		4650-7920	
126	Top hook with Latch assembly	1	9634-0002	9634-0059	9634-0014	9634-0052
127	Bottom Hook Assembly(*)	1	3634-0013	3634-0032	3634-0015	3634-0027
128	Pin	1	4600-0516			
129	Hook Ring	1	9609-0025	9609-0146		
130	Retainer Wire	1	4790-1239	9609-0148		
131	Ball	10	6940-1125			
132	Washer	1	9609-0060			
133	Buffer	2	9634-0022			
135	Bottom Hook with Latch assembly	1	9609-0083	9609-0139	9634-0008	9634-0051
136	Nut	1	4370-3411	4370-7611	4370-3411	4370-7611
137	Screw	1	4130-0506	4132-1706	4130-0506	4132-1706
138	Hook Support	1	9634-0012	9634-0058	9634-0009	
139	Greaser	1	6710-2627			
• 140	O' Ring	1	5821-5829			
141	Block Flange	1	9634-0007			
142	Block Flange	1	9634-0068			
143	Block Wheel	1			9634-0010	9634-0050
144	Washer	3			4520-0006	4520-1006
145	Nut	3			4300-0711	4300-6211
146	Screw	3			4130-0406	4132-2306
147	Roll Pin	1	4650-8020			
148	Roll Pin	1	4650-8120			
• 149	Ball Bearing	2	5005-0007			
• 150	Thrust Ball Bearing	1	5400-0005			

Hoist Assembly with Option "X".

Substitute or add the following parts on hoist with option "X"

		QTY	0,8T	1,6T
120	Load Chain	(meter)	6902-7041	

• Recommended Spare.

(*) Bottom Hook Equipment for 0,8 to 1 Ton hoist (incl's item 128 through 139)
Bottom Hook Equipment for 1,6 to 2 Ton (incl's item 133 through 150)

REMOTE CONTROL ASSEMBLY DRAWING

REAR VIEW OF PALAIR PLUS HOIST

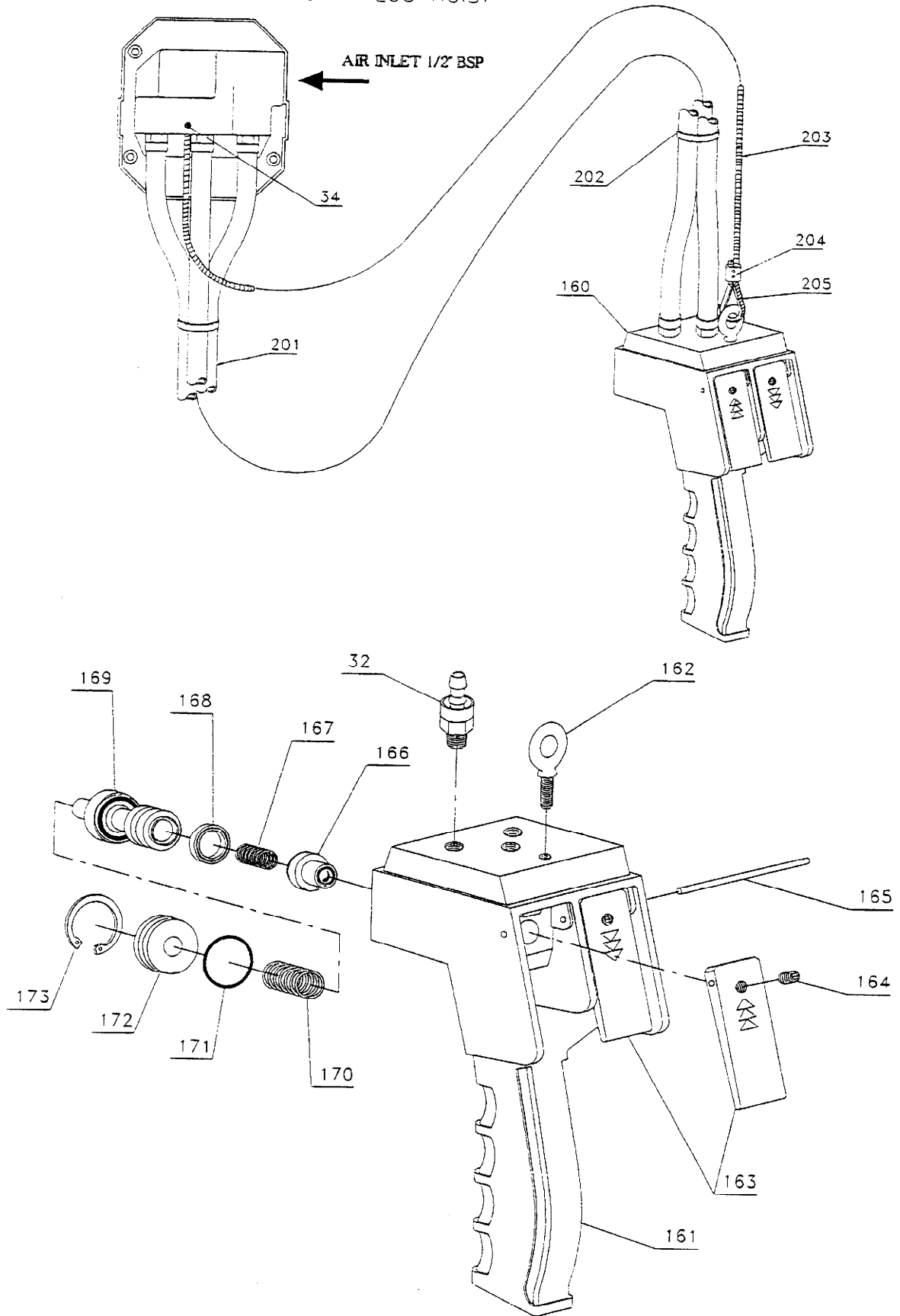

(Dwg.D6090018)

REMOTE CONTROL ASSEMBLY PART LIST

ITEM NO.	DESCRIPTION OF PART	QTY TOTAL	PART NO.
34	Setscrew	1	4200-5507
32	Fitting	3	6165-2632
160	Pendant Assembly (incl's item 32 and 161 through 173)	1	7579-0038
161	Pendant Handle	1	9579-0034
162	Lifting Eye	1	6422-2332
163	Lever	2	9579-0038
164	Setscrew	2	4200-7407
165	Pin	1	9579-0040
166	Valve Assembly (with 'O' Ring crimped)	2	9579-0036
167	Spring	2	6915-8632
• 168	Quad Ring	2	5823-0239
169	Spool (with 'O' Ring crimped)	2	9579-0035
170	Spring	2	6915-8732
• 171	O' Ring	2	5820-3729
172	Rear Cover	2	9579-0037
173	Retainer Ring	2	4770-3028
200	Meter of Control (incl's item 201 through 203)	(*)	3387-0031
201	Hose	3	-
202	Hose Tie	2	-
203	Strain Relief Wire	1	-
204	Sleeve Clamp	1	6112-5032
205	Thimble	1	6932-5332

• Recommended Spare.

(*) Specify length of control when ordering

REMOTE CONTROL ASSEMBLY DRAWING

REAR VIEW OF PALAIR PLUS HOIST

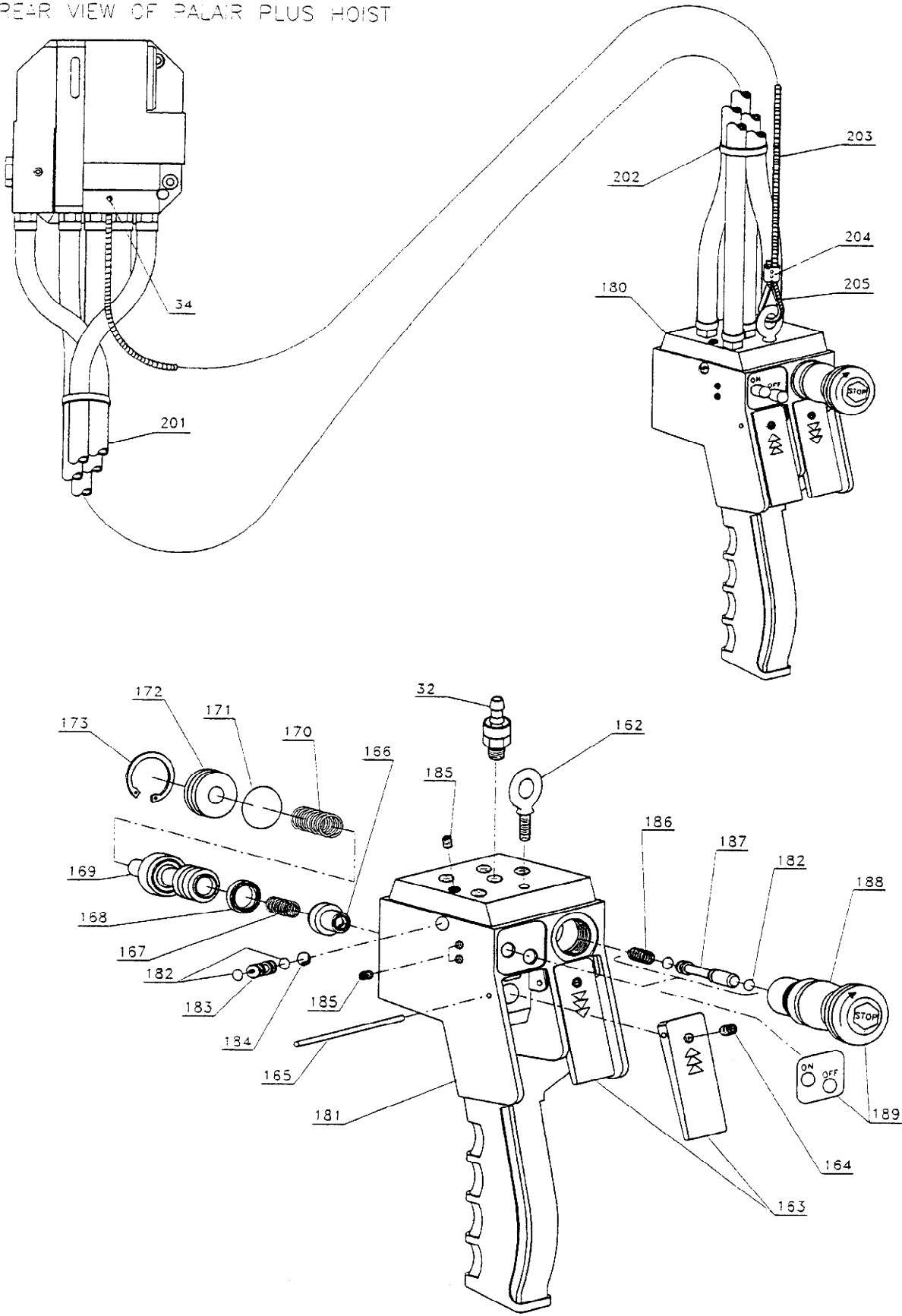

(Dwg.D6340012)

REMOTE CONTROL ASSEMBLY PART LIST

ITEM NO.	DESCRIPTION OF PART	QTY TOTAL	PART NO.
34	Setscrew	1	4200-5507
32	Fitting	5	6165-2632
162	Lifting Eye	1	6422-2332
163	Lever	2	9579-0038
164	Setscrew	2	4200-7407
165	Pin	1	9579-0040
166	Valve Assembly (with 'O' Ring crimped)	2	9579-0036
167	Spring	2	6915-8632
* 168	Quad Ring	2	5823-0229
169	Spool (with 'O' Ring crimped)	2	9579-0035
170	Spring	2	6915-8732
* 171	'O' Ring	2	5820-3729
172	Rear Cover	2	9579-0037
173	Retainer Ring	2	4770-3028
180	Pendant With Emergency Stop Assembly (incl's item 32 through 173 and 181 through 189)	1	7579-0071
181	Pendant Handle	1	9579-0095
* 182	'O' Ring	8	5820-9229
183	Shuttle Valve Stop	1	9579-0098
184	Ball	1	6940-1625
185	Setscrew	3	4200-8207
186	Spring	3	6911-3941
187	Spool	3	9579-0085
188	Emergency Stop Bottom	1	6859-8632
189	Label Kit	1	9579-0099
* 190	Sticker	1	9618-0098
* 191	Sticker	1	9618-0100
201	Hose	5	-
202	Hose Tie	2/m	-
203	Strain Relief Wire	1	-
204	Sleeve Clamp	1	6112-5032
205	Thimble	1	6932-5332
206	Meter of Control (incl's item 201 through 203)	(*)	3525-0003

* Recommended Spare.

(*) Specify length of control when ordering

* Not Shown on drawing

CHAIN BUCKET ASSEMBLY DRAWING AND PART LIST

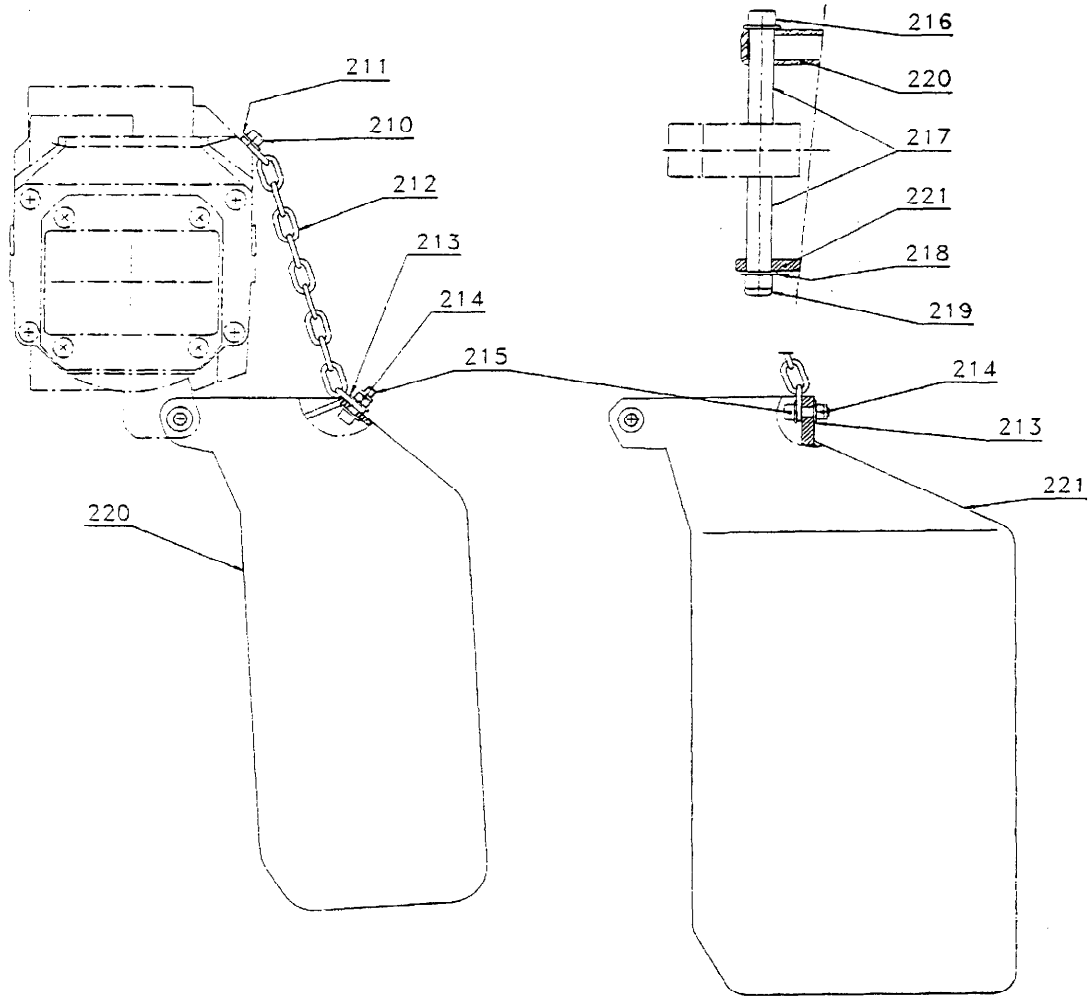

(Dwg.D6340014)

ITEM NO.	DESCRIPTION OF PART	QTY TOTAL	PART NO.	
			STANDARD	OPTION "R"
210	Screw	1	4130-6706	4132-2606
211	Flat Washer	1	4500-0105	4500-1105
212	Balance Chain	0,16m	6903-3232	
213	Flat Washer	2	4500-1105	
214	Locknut	1	4370-7211	
215	Screw	1	4132-2906	
216	Screw	1	4132-9706	
217	Distance Washer	2	9634-0018	
218	Flat Washer	2	4500-1108	
219	Locknut	1	4370-7011	
220	Chain Conteneur for 6 meters of chain	1	9634-0017	
221	Chain Conteneur for 12 meters of chain	1	9634-0028	
	Chain Conteneur for 18 meters of chain	1	9634-0047	
222	CB2000-6M (incl's item 212 through 220)	1	7634-0025	
	CB2000-12M (incl's item 212 through 219 and 221)	1	7634-0026	
	CB2000-18M (incl's item 212 through 219 and 221)	1	7634-0027	

HOIST AND WINCH LIMITED WARRANTY

See our general conditions of sales mentioned on our proposal, acknowledgement receipt, invoice.

IR/SAMIIA guarantees the equipment sold and supplied by itself against any defect or flaw in manufacture or operation under the conditions and within the limits hereafter.

- the guarantee is only valid if the customer has satisfied the general obligations of the present contract and, in particular, of settlement.

- the guarantee is strictly limited to IR/SAMIIA equipment. It does extend to supplies and accessories which are not of its manufacture.

- the guarantee does not extend to assemblies or machines in which IR/SAMIIA equipment is incorporated and in particular to the performances of these assemblies or machines.

- when IR/SAMIIA equipment is incorporated into one or other assembly or machine by the customer, he alone is responsible for the adaptation, the choice and the suitability of the IR/SAMIIA equipment, IR/SAMIIA's diagrams, surveys and layouts being given only for guidance, unless there is a special stipulation in the acceptance of order, defined in the acknowledgment of receipt.

- IR/SAMIIA does not guarantee components and accessories it does not sell.

Defects in fitting, adaptation, design, connection and running of the assembly or part of the assembly put together by the customer are not covered by the guarantee. IR/SAMIIA equipment and material as well as the assemblies or machines set up by the customer or by a third party are assumed to be operated and used under the sole control of the customer or third party.

- The duration of the guarantee is for 6 months from the start up of the equipment by the customer. The start up must be made at the latest three months after dispatch of the equipment or its being made available.

- IR/SAMIIA has the right to demand from its customer proof of the date of start up.

- The guarantee period is reduced to half if the equipment is used day and night.

- The length of guarantee is neither prolonged nor interrupted by either amicable or litigious claims by the customer.

- At the expiry of this period, the guarantee ceases incontestably.

- The obligations of the IR/SAMIIA guarantee will only come into effect if the customer proves that the defect or flaw appeared

during normal operating conditions for this type of material, or in the course of normal use as specified by IR/SAMIIA.

- It does not apply in the event of user's mistake, negligence, imprudence, faulty superintendence or maintenance, inattention to the instructions or directions for use of low quality lubricants. IR/SAMIIA's liability is disclaimed for all damage brought about by loss or leaks of oil.

- No guarantee applies either for fortuitous incidents or force majeure, or for wear, replacements or repairs caused by normal use of the equipment.

- The guarantee is restricted to reconditioning in IR/SAMIIA's premises at its expense and as soon as possible the equipment and parts recognized as faulty by its technical or after sales services, which are sent carriage paid and packing free, without there being any claim for damage arising, such as injury to personnel, damage to property other than that covered by the present contract, loss of possession, of production, commercial detriment or loss of profit.

- During the guarantee period, the cost of labour for dismantling and reassembling equipment outside IR/SAMIIA's premises, the cost of moving faulty, replaced or repaired equipment and the travelling and living expenses of IR/SAMIIA's engineers are covered exclusively by the customer.

- In order to obtain the advantages of the guarantee, the customer must advise IR/SAMIIA without delay and in writing of the defects and flaws in his equipment of which he is complained and furnish proof of their genuine nature. He must give IR/SAMIIA or its agents or technicians every facility to verify the defects or flaws and to put them right.

- The guarantee does not apply if the equipment is returned to IR/SAMIIA in a condition other than in which it broke down or if the seal has been removed, or if it has been dismantled, repaired or modified by a third party, or by the user or the customer.

- After having been duly informed of the defect or flaw in its equipment, IR/SAMIIA will put it right as quickly as possible, reserving the right, in certain cases, to modify the whole or part of the equipment so as to meet its obligations.

- The customer agrees that IR/SAMIIA will not be responsible for damage in the event that the customer has not fulfilled one or other of the obligations set out above.

- Parts replaced free of charge remain the property of IR/SAMIIA.

- The guarantee does not apply to wearing parts.

IMPORTANT NOTICE

It is our policy to promote safe delivery of all orders.

This shipment has been thoroughly checked, packed and inspected before leaving our plant and receipt for it in good condition has been received from the carrier. Any loss or damage which occurs to this shipment while enroute is not due to any action or conduct of the manufacturer.

VISIBLE LOSS OR DAMAGE

If any of the goods called for on the bill of lading or express receipt are damaged or the quantity is short, do not accept them until the freight or express agent makes an appropriate notation on your freight bill or express receipt.

CONCEALED LOSS OR DAMAGE

When a shipment has been delivered to you in apparent good

condition, but upon opening the crate or container, loss or damage has taken place while in transit, notify the carrier's agent immediately.

DAMAGE CLAIMS

You must file claims for damage with the carrier; It is the transportation company's responsibility to reimburse you for repair or replacement of goods damaged in shipment. Claims for loss or damage in shipment must not be deducted from the **Ingersoll-Rand** invoice, nor should payment of **Ingersoll-Rand** invoice be withheld awaiting adjustment of such claims as the carrier guarantees safe delivery. You may return products damaged in shipment to us for repair, which services will be for your account and form your basis for claim against the carrier.



Back Blank