

PARTS AND MAINTENANCE MANUAL FOR "LIFTSTAR" AND "PULLSTAR" AIR WINCHES MODELS LS1500R & PS2400R SERIES

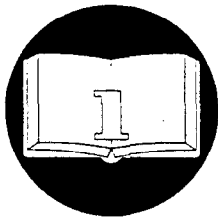

READ THIS MANUAL BEFORE USING THESE PRODUCTS. This manual contains important maintenance information. Make this manual available to all persons responsible for the maintenance of these products.

⚠ WARNING

Do not use this winch for lifting, supporting, or transporting people or lifting or supporting loads over people.

Always operate, inspect and maintain this winch in accordance with European Security Rules and any other applicable safety codes and regulations.

Refer all communications to the nearest IR/SAMIIA Material Handling Products Office or Distributor.

Form SAM0072
Edition 5
January 1998
96310124
©1998 Ingersoll-Rand Company

INGERSOLL-RAND

MATERIAL HANDLING

TABLE OF CONTENTS

Description	Page No.
Maintenance	
Maintenance Intervals.....	3
General Disassembly	4
Disassembly Instructions	4
Winch Disassembly	4
Lever Control Valve disassembly.....	5
Air Control Valve disassembly - Optional Europ Version	5
Air Gear Motor disassembly.....	5
Pendant Control disassembly.....	5
Pendant Control emergency stop disassembly.....	5
Shut-off valve disassembly.....	6
Emergency stop valve disassembly.....	6
Cleaning, Inspection and Repair	6
Assembly Instructions.....	6
Winch Assembly.....	6
Lever Control Valve Assembly	7
Air Gear Motor Assembly	8
Pendant Control Assembly	8
Pendant Control with emergency stop Assembly.....	8
Pendant Control Adjustment.....	8
Accessories	9
Testing	9
Parts	
Winch Assembly Drawing	10
Winch Assembly Parts List.....	11
Air Gear Motor Assembly Drawing.....	12
Air Gear Motor Assembly Part List.....	13
Lever Control Valve Assembly Drawing and Part List.....	14
Control Valve Assembly Drawing and Parts List	15
Control Valve Assembly Drawing and Parts List	16
PHS2 Remote Control Assembly Drawing and Part List.....	17
PHS2U Remote Control with Emergency Stop Assembly Drawing and Part List.....	18
Shu-off Valve Assembly Drawing and Parts List.....	19
Emergency Stop Valve Assembly Drawing and Parts List	20
Torque Limitor Assembly Drawing and Parts List	21
Drum Guard Assembly Drawing and Parts List.....	22
Parts Ordering Information	
Warranty	23
Office Location	24

⚠ WARNING

- Never perform maintenance on the winch while it is supporting a load.
- Before performing maintenance, tag controls:
DANGER - DO NOT OPERATE - EQUIPMENT BEING REPAIRED.
- Only allow service personnel trained in safety and maintenance on this winch to perform maintenance.
- After performing any maintenance on the winch, test winch to 125% of its rated capacity before returning to service. Testing to more than 125% of rated capacity may be required to comply with standards outside the USA.
- Shut off air system and depressurize air lines before performing any maintenance.
- Do not use Trichloroethylene to clean parts.

Maintenance Intervals

The Maintenance Interval chart is based on intermittent operation of the winch eight hours each day, five days per week. If winch operation exceeds eight hours per day, or use is under HEAVY or SEVERE conditions, more frequent maintenance should be performed. Refer to 'Periodic Inspection' in the "INSPECTION" section for interval guidance.

INTERVAL	MAINTENANCE
Start of each shift (Operator or Maintenance Personnel)	Make a thorough visual inspection of the winch for damage. Do not operate the winch if damaged. Operate the winch at low RPM in both directions. Winch must operate smoothly without sticking, binding or abnormal noises. Check the operation of the brake.
Yearly (Maintenance Personnel)	Inspect the brake disc. Clean or replace parts as required. Inspect the winch gearing, shafts and bearings for wear and damage. Repair or replace as necessary. Check all the supporting members, including the foundation, fasteners, nuts, sheaves and rigging, etc. for indications of damage or wear. Repair or replace as required.

Motor Removal

(Ref. Dwg. D6310041)

Use the following procedure to remove the motor.

1. Disconnect and tag the air lines.
2. Position several blocks of wood on the work bench and stand the winch in a vertical position with the motor end up. Make sure the weight of the winch does not rest on the free wheel handle (65) or cause damage to the free wheel parts
3. Remove the four capscrews (113) and lockwashers (114) which connect the air motor to the front end cover (30) and remove the motor assembly.

Brake

It is recommended that the brake assembly be removed for maintenance and inspection once each year.

Adjustment

No brake adjustment is required.

Inspection

If brake slippage occurs during tests prior to placing winch in service or during normal use of the winch, following the winch disassembly procedure until number 14.3 and check dimension « C » from the brake piston (26) to the gear box (45) as shown in Dwg. D6310032. If this dimension is greater than 0,12 in. (3 mm), the brake discs (21 and 22) must be replaced by following the winch disassembly procedure.

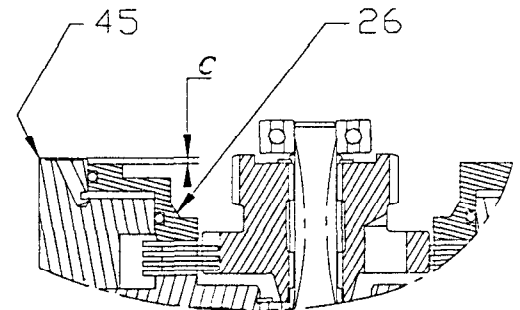

(Dwg. D6310032)

General Disassembly Procedures

The following instructions provide the necessary information to disassemble, inspect, repair, and assemble the winch. Refer to the winch assembly drawing provided in the Parts Section.

If a winch is being completely disassembled for any reason, follow the order of the topics as they are presented.

It is recommended that all maintenance work on the winch be performed on a bench in a clean dust free area. In the process of disassembling the winch, observe the following :

1. Never disassemble the winch any further than is necessary to accomplish the needed repair. A good part can be damaged during the course of disassembly.
2. Never use excessive force when removing parts. Tapping gently around the perimeter of a cover or housing with a soft hammer, for example, is sufficient to break the seal.
3. Do not heat a part with a flame to free it for removal, unless the part being heated is already worn or damaged beyond repair and no additional damage will occur to other parts.

In general, the winch is designed to permit easy disassembly and assembly. The use of heat or excessive force should not be required.

4. Keep the work area as clean as practical, to prevent dirt and other foreign matter from getting into bearings or other moving parts.
5. All seals and 'O' rings should be discarded once they have been removed. New seals and 'O' rings should be used when assembling the winch.
6. When grasping a part in a vise, always use leather-covered or copper-covered vise jaws to protect the surface of the part and help prevent distortion. This is particularly true of threaded members and housings.
7. Do not remove any part which is press fit in or on a subassembly unless the removal of that part is necessary for repairs or replacement.
8. When removing ball bearings from shafts, it is best to use a bearing puller. When removing bearings from housings, drive out the bearing with a sleeve slightly smaller than the outside diameter of the bearing. The end of the sleeve or pipe which contacts the bearing must be square. Protect bearings from dirt by keeping them wrapped in clean cloths

Disassembly Instructions

Winch Disassembly

(ref.Dwg.D6310041)

1. Disconnect and tag the air lines.
2. Remove winch from its mounting and set in a clean work area on a sturdy work bench.
3. Position several blocks of wood on the work bench and stand the winch in a vertical position with the motor end down.
4. Remove the nuts (2) and lock washers (3).

5. Remove the rear end-cover (55).
 - 5.1. Extract the exhaust washers (60) and the rings (59).
 - 5.2. Pull bearing (58) from rear end cover (55)
 6. Clutch control disassembly (PS SERIES)
 - 6.1. Unscrew the handle (65) and pull the plunger (61) to remove clutch axle (66), clutch (72) and the spring (69).
 - 6.2. If necessary remove retainer rings (62 and 63) to remove clutch (72) and bearing (71) from clutch axle (66)
 - 6.3. Remove screws (67), washer (68), plunger body (70) and the plunger (61)
 7. Remove the drum (56) from the winch.
 - 7.1. Remove the spacer (64). Only for PS series.
 - 7.2. Remove the drum bushings (38) from the drum (56) if they require replacement.
 8. Remove the oil drain plug (6) and return the winch to drain the oil from the gear casing.
 9. Remove the four screws winch secure the motor (29) to the front end cover (30) and pull off the motor straightaway from the winch. For disassembly of the motor and the valve, follow the corresponding procedure.
 10. Remove the gasket (31) and the 'O'ring (27) and drain the oil from the brake through the front end cover bore.
 11. Remove the three nuts (2) and lock washers (3) and remove the three tie rod spacers (4).
 12. Remove the output shaft (5) from the gearbox and brake assembly.
 13. Disassembly of the front end-cover (30).
 - 13.1. Remove the screws (34).
 - 13.2. Remove the front end cover (30).
 - 13.3. Remove the retainer ring (32).
 - 13.4. Remove the oil seal (35).
- NOTICE**
- The oil has been installed with loctite ® 460 on the backside of the seal.
14. Disassembly of the brake piston.
 - 14.1. Remove the O'ring (25) and the gasket (33).
 - 14.2. Remove the springs (41).
 - 14.3. Remove the bearing (36).
 - 14.4. Extract the brake piston (26) by using low pressure compressed air in brake release port.
 15. Disassembly of the gear box
 - 15.1. Remove screws (47) and lock washers (48).
 - 15.2. Extract the gear box cover by using jacking screws in the two M4 threaded holes.
 - 15.3. Press out the output shaft (5) and the output annular gear (50).
 - 15.4. Remove the bearings (51 and 53), oil seal (52) and the O'ring (9).
 - 15.5. Remove the bearing (10), spring washer (49) and the output annular gear (50).
 - 15.6. Remove the satellite support assembly.
 - 15.7. Push out the satellite axles (11).
 - 15.8. Remove the planet gear (15), bearing studs (12) and stop rings (13).

- 15.9. Remove the needle bearings (14) and the spacers (16).
- 15.10. Disassembly of the fixed annular gear (19), friction discs (21) and steel discs (22) :
 - compress the 'O'ring (20) by using the special tool M6313400.
 - remove the retainer ring (17).
 - push out the fixed annular gear (19).
 - remove the 'O'ring (9).
 - remove the pins (39).
 - remove the 'O'ring (20).
 - remove the friction discs (21) and steel discs (22).
- 15.11. Disassembly of the shaft spindle (18).
 - remove the retainer ring (37).
 - remove the gear wheel (43).
 - push out the shaft spindle (18).
- 15.12. Remove the retainer ring (40).
- 15.13. Remove the bearing (44).

Lever Control Valve Disassembly (ref. Dwg. D6310006 or D6310035)

1. Remove screws (130) and lock washers (131).
2. Remove the lever control valve assembly from the motor.
3. Tap out the pin (128).
4. Extract the control lever (121).
5. Remove screws (127) to remove stop (129).
6. Remove the return spring (124).
7. Pull out the rotary valve (126).

NOTICE

- Localise the mounting position of the rotary valve in the valve housing.
8. Remove the 'O'ring (125) from the rotary valve (126) if necessary.

Valve Disassembly Optional Remote Control (ref. Dwg. D6310026)

1. Remove screws (143).
2. Remove the valve assembly from the motor.
3. Remove the cover (144) from the valve body (150).
4. Remove screws (141) and lock washers (142).
5. Remove the end caps (147) and the rear stops (148).
6. Remove the slide valves (149) and return spring (145).
 - 6.1. Remove the quad rings (151).
7. Remove the quad rings (146) from the valve body.

NOTICE

- The cover (4) has been installed with Loctite® instajoint No 574.

Air Gear Motor Disassembly (Ref. Dwg. D6310005)

Refer to control valve disassembly sections to remove lever or pendant control valve from motor

1. Remove the screws (81) and lock washers (82).
2. Remove the motor housing (112).
3. Remove the 'O'ring (110).
4. Remove the gasket (95).
5. Remove screws (109).
6. Remove the motor cover (84).
 - remove the 'O'rings (89) and pin (83).
 - remove the exhaust washer (87) and the plug (88).
 - remove the needle bearings (85 and 91) if they have to be changed.
7. Immobilise the motor rotors with a pin between the teeth and remove nuts (101 and 106).
8. Remove the motor rotors (93 and 94).
 - remove the shaft segment (86) and the internal ring.
9. Remove the screw (104) and the washer (103).
10. Remove ball bearings (100 and 107).
11. Remove the spacer (92).
12. Remove the stopper (108), the spring (102) and the rear stop (105).

“PHS2” Pendant Control Disassembly (Ref. Dwg. D5790002)

1. Disconnect all hoses from winch motor.
2. Remove the fittings (161) and the lifting eye (170).
3. Remove the retainer ring (162).
4. Pull out rear covers (164) with the 'O' rings (163).
5. Remove the springs (165).
6. Remove the “slide valve assemblies” (166) with the quad rings (167).
7. Remove the springs (168).
8. Remove the valve cone assemblies (169).
9. Remove the setscrews (174).
10. Tap out pin (171) to remove the levers (173).

“PHS2U” Pendant Control with Emergency Stop Disassembly

(Ref. Dwg. D5790003)

Refer to PHS2 control disassembly to begin PHS2U disassembly

11. Remove emergency stop button (179).
12. Remove the setscrews (175).
13. Remove the spools (178).
14. Pull on the shuttle valve stop (180) with ball (176).
15. Remove the 'O' rings (181) from shuttle valve stop and spool (178).

Shut-off Valve Disassembly

(Ref. Dwg.D6170004)

1. Remove the screw (202).
2. Remove the cover (201) with the spring (203).
3. Remove the 'O' ring (204) from the cover (201).
4. Remove the cover (213) and the 'O' ring (215).
5. Remove the diaphragm (211).
6. Immobilise the valve cone (214) by its hole with a rod in one of two orifices of the body (209) and remove the screw (208).
7. Remove the valve cone (205,214) with joints (206) and distance ring (210) with the washer (207).

Emergency Stop Valve Disassembly

(Ref. Dwg.D6170003)

Refer to air control valve disassembly to begin disassembly

8. Remove emergency stop button (179).
9. Remove the setscrews (175).
10. Remove the spools (178).
11. Pull on the shuttle valve stop (180) with ball (176).
12. Remove the 'O' ring (181) from shuttle valve stop (180) and spool (176).

Cleaning, Inspection and Repair

Use the following procedures to clean, inspect, and repair the components of the winch.

- A bearing that appears loose or does not rotate smoothly must be replaced. Failure to observe this precaution will result in bearing and/or winch component damage.

Clean all winch component parts in solvent (except for the brake friction disc). The use of a stiff bristle brush will facilitate the removal of accumulated dirt and sediments in the drum and reduction assembly. If drum bushings have been removed it may be necessary to carefully scrape old Loctite® from the drum bushing bore. Dry each part using low pressure, filtered compressed air. Clean the brake friction disc using a wire brush or emery cloth. Do not wash the brake friction disc in liquid. If the brake friction discs are oil soaked, they must be replaced.

Inspection

All disassembled parts should be inspected to determine their fitness for continued use. Pay particular attention to the following:

1. Inspect all gears for worn, cracked, or broken teeth.
2. Inspect all bushings for wear, scoring or galling.
3. Inspect all bearings for play, distorted races, pitting and roller or ball wear or damage. Inspect bearings for freedom of freedom
4. Inspect shafts for ridges caused by wear. If ridges caused by wear are apparent on shafts, replace the shaft. Inspect all surfaces on which oil seal lips seat. These surfaces must be very smooth to prevent damage to the seal lip.

5. Inspect all threaded items and replace those having damaged threads.
6. Inspect all remaining parts for evidence of damage. Replace or repair any part which is in questionable condition. The cost of the part is often minor in comparison with the cost of redoing the job.
7. Smooth out all nicks, burrs, or galled spots on shafts, bores, pins or bushings. Examine all gear teeth carefully, and remove nicks or burrs.
8. Polish the edges of all shaft shoulders to remove small nicks which may have been caused during handling.
9. Remove all nicks and burrs caused by lockwashers.
10. Replace all gaskets, oil seals, and O'rings any time the winch is disassembled for repair.
11. Inspect drum bushings (47) for wear, if thickness is less than 0.039 in. (1 mm), replace drum bushings.
12. Inspect brake discs (21 and 22) for wear, if thickness less than 0.354 in. (9 mm), replace them.

Repair

Actual repairs are limited to the removal of small burrs and other minor surface imperfections from gears and shafts. Use a fine stone or emery cloth for this work. Do not use steel wool.

1. Worn or damaged parts must be replaced. Refer to the applicable Parts Listing for specific replacement parts information.
2. Inspect all remaining parts for evidence of damage. Replace or repair any part which is in questionable condition. The cost of the part is often minor in comparison with the cost of redoing the job.
3. Smooth out all nicks, burrs, or galled spots on shafts, bores, pins, or bushings.
4. Examine all gear teeth carefully, and remove nicks or burrs.
5. Polish the edges of all shaft shoulders to remove small nicks which may have been caused during handling.
6. Remove all nicks and burrs caused by lockwashers.
7. Replace all gaskets, oil seals, and 'O' rings removed during winch disassembly.

Assembly Instructions

Winch Assembly

(Ref. Dwg. D6310041)

1. Gear box assembly.
 - 1.1. Assembly of the shaft spindle (18)
 - Install bearing (44) with the retainer ring (40)
 - Put the shaft spindle (18) in the bearing (4). Install the gear wheel (43) with the retainer ring (37)
 - 1.2. Assembly of the fixed annular gear (19).
 - Install the friction disc (21) and steel disc (22) in the gear box (45).
 - Install the 'O' ring (20) and the pin (39).
 - Install the 'O' ring (9) in the fixed annular gear (19), install this ass'y in the gear box (45) and secure with the retainer ring (17).

- 1.3. Install the needle bearings (14) and the spacer (16) in the planet (15).
- 1.4. Install the three planet ass'y, bearing studs (12) and stop rings (13) in the planet support (46).
- 1.5. Install the planet axle (11) and the bearing (10).
- 1.6. Install the planet support assembly.
- 1.7. After assembly of planet support (46) with the fixed annular gear (19) and the shaft spindle (18), check for good indexing of planet gears and repeat the above operation if necessary.

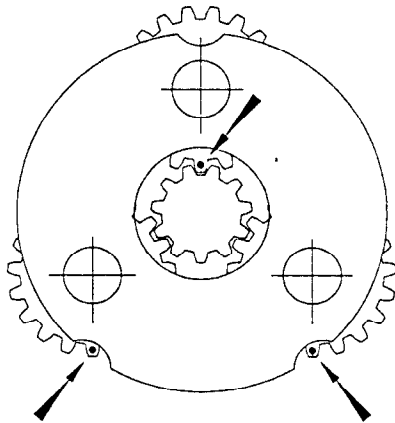

(Dwg.D6310013)

⚠ CAUTION

- For correct assembly of planet gears, each planet gear must be positioned with the timing mark as shown on drawing D6310013.

- 1.8. Install the spring washer (49) and the output annular gear (50).
- 1.9. Assembly of the box cover
 - Install the oil seal (52) and the bearing (51 and 53).
 - Install the output shaft (5) with the retainer ring (54) in the gear box cover.
 - Install the 'O' ring (9).
 - Install the gear box cover ass'y and secure with screws (47) and washers (48).
2. Assembly of the brake piston
 - 2.1. Install the brake piston with the 'O' rings (23 and 25).
 - 2.2. Install bearing (36), spring (41) and gasket (33).
3. Assembly of the front end cover.
 - 3.1. Clean the mounting front end cover (30) bore and apply a bead of Loctite No.460 on the backside of the oil seal (35). Install the oil seal.
 - 3.2. Install the retainer ring (32).
 - 3.3. Install the front end cover (30) and secure with screws (34).
4. Install the three tie rod spacer (4) with the nuts (2) and the washer (3).

5. Fill up the brake with oil.
6. Install the gasket (31) and the 'O' ring (27).
7. Install the motor ass'y and secure with the four screws.
8. Position the winch vertically with the motor end down.
9. Fill up the gear box with oil SAE 80W90
 - kinematics viscosity 145 mm²/s at 40°C(104°F)
 - capacity of gear box : 0.13 gall (0.5 Litres)
10. Drum assembly
 - 10.1. Scrape old Loctite from the drum bushing bore and apply a bead of Loctite N°406 on the smooth face of drum bushings (38).
 - 10.2. Install drum bushing in drum bushing bore by taking care to adjust the gaps of the drum bushing to 3.9 ins (100mm) do not allow any clearance between drum bushings and drum.
 - 10.3. Lubricate drum bushings with grease.
 - 10.4. Install the drum on the gear box assembly.
 - 10.5. Lift out the drum to check for good positioning of drum bushing
11. Clutch control assembly (PS SERIES)
 - 11.1. Install plunger body (70) and plunger (61) on the rear end cover (55) and secure with screw (67) and washer (68).
 - 11.2. Install bearing (71) on clutch axle (66) with retainer ring (65) and install the clutch (72) with the retainer ring (62).
 - 11.3. Pull the plunger (61) to introduce the clutch axle with the spring (69) into the plunger body (70) and install the handle (65).
12. Assembly of the rear end cover (55).
 - 12.1. Install bearing (58) on the rear cover.
 - 12.2. Install exhaust washers (69) with ring (59).
13. Install spacer (64) on the output shaft (PS SERIES). Install the rear end cover Ass'y on the three tie rod (4) and secure with lock washers (3) and nuts (2).

Lever Control Valve Assembly

(Ref. Dwg.D6310006 or D6310035)

1. Lubricate and install 'O' ring (125) on rotary valve (126).
2. Lubricate and carefully install rotary valve in valve housing (122).
3. Lubricate and install spring (124) on rotary valve. Ensure pin (123) is installed in valve housing (122).
4. Install stop (129). Apply a small amount of Loctite® 243 to threads of screws (127) and install.
5. Install control handle (121) on rotary valve and align pin hole. Install pin (128) to secure control handle.

Air Gear Motor Assembly

(Ref. Dwg. D6310005)

1. Install the stop (105), spring (102) and stopper (108).
2. Install the spacer (92).
3. Install the bearing (100 and 107) and secure with the screw (104) and washer (103).
4. Install the internal ring of the bearing (85) on the rotor motor (84) and secure with the retainer ring (86).
5. Install the motors rotors with a pin between the teeth and secure with the nuts (101 and 106).
6. Install the pin (83), the needle bearing (85 and 91), the 'O' ring (89), the exhaust washer (87) and the plug (88) in the motor cover.
7. Install the motor ass'y on the motor cover with the screws (109)
8. Install the 'O' ring (110) and the gasket (95) in the motor housing (112).
9. Install the motor ass'y in the motor housing (112) and secure with the screws (81 and 82).

NOTICE

- To correctly assemble the exhaust washer, spacers, valve and spring, carefully follow instructions:
 - Take the motor body and put it in the same position as mounting on the winch and view from the backside of the motor body, stopper, spring, valve and the spacer must be mounted in the left bore. Check for good functioning of the valve.
 - The exhaust washer must be mounted on the same side as the valve in the right bore.
 - Before assembly lubricate bearing with grade 2 grease.
 - Install ball bearings so markings on bearing remain visible.
 - After assembly of the air motor, it must turn smoothly in both direction.
 - The screws (104 and 109) the nuts (101 and 106) must be secured with Loctite ® 243, secure the nuts with a centre punch.

'PHS2' Pendant Control Assembly

(Ref. Dwg. D5790002)

1. Install lever (173) in pendant handle (172) with pin (171). Stake pin in pendant handle at both ends to secure.
2. Install setcrews (174).
3. Check that 'O' ring is undamaged and securely crimped in valve. Install valve assemblies (169).
4. Install springs (168).
5. Check that 'O' ring is undamaged and securely crimped in spool. Install quad ring (167) and spools (166).
6. Install springs (165).
7. Lubricate and install 'O' ring (163) on rear cover (164). Install rear cover in pendant handle.
8. Install retainer rings (162).

'PHS2U' Pendant Control with Emergency Stop Assembly

(Ref. Dwg. D5790003)

Refer to PHS2 control assembly to begin PHS2U assembly.

9. Install 'O' ring (181) on shuttle valve stop (180) and spool (178).
10. Install that shuttle valve stop (180) with ball (176), those spools (178) in pendant handle (172) and secure with setscrew (175).
11. Install the emergency stop bottom (179).
12. Install the eyebolt (170) and fitting (161).

Pendant Control Adjustment.

1. Connect the inlet of the pendant to 100 psi (7 bar) air supply.
2. Connect a manometer at the outlet of the lever to be adjusted.
3. Apply a small amount of Loctite® No. 243 on the adjustment setscrew (174).
4. Tighten the adjustment setscrew to obtain a pressure of 15 psi (1 bar) without action the lever.
5. Release the adjustment setscrew by a half turn (pressure must fall to zero).
6. Push the lever. Check that pressure reaches 93 +/- 7 psi (6.5 +/- 0.5 bar). Check that there is no leak at the exhaust.
7. Release the lever, exhaust must occur and result in rapid pressure reduction.
8. Repeat operations "6 and 7" from 2 to 3 times.
9. Disconnect the manometer. Check to ensure that there are no leaks when the lever is not activated.
10. Repeat the operations from 2 to 9 with each lever.

ACCESSORIES

Tooling installation M6313400
(Dwg.D6310031)

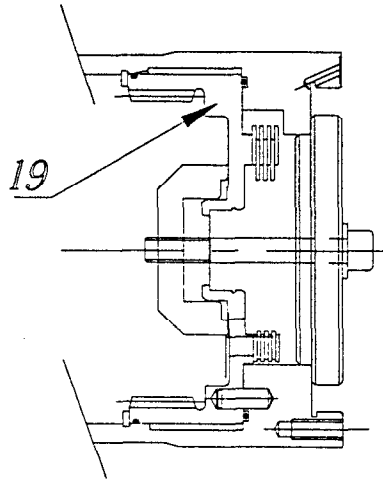

TEST

Testing

Operational Tests

Prior to initial use, all new, altered or repaired winches shall be tested to ensure proper operation.

1. Operate winch in both directions with no load.
2. Check operation of free wheel and brake.
3. Check operation of limit switches and other safety devices when provided.
4. Check all winch mounting bolts are secure.

Load test

Prior to initial use, all new, extensively repaired, or altered winches shall be load tested by or under the direction of a person trained in the operation and service of this winch and a written report furnished confirming the rating of the winch.

- For air winches LS series.

The minimum load test for European countries are according to the chart below. If not found below you should use the tests recommended by the FEM.

The dynamic test shall be carried out with an overload coefficient $p_1 = 1,2$ i.e. with a load equal to 120% of the safe working load. All motions shall be carefully operated in turn, without checking speeds of temperature rises in the motors.

the static test shall be carried out with an overload coefficient $p_2 = 1,4$ i.e. with a load equal to 140% of the safe working load. The test must be carried out under still conditions and consists in hoisting the safe working load to a small distance above the ground and then adding the required surplus without shock.

- For air winches PS series.

The dynamic test shall be carried out with the nominal line pull.

The static test shall be carried out with an overload coefficient $p_2 = 1,4$ i.e. with a load equal to 140% of the safe working load.

WINCH ASSEMBLY DRAWING

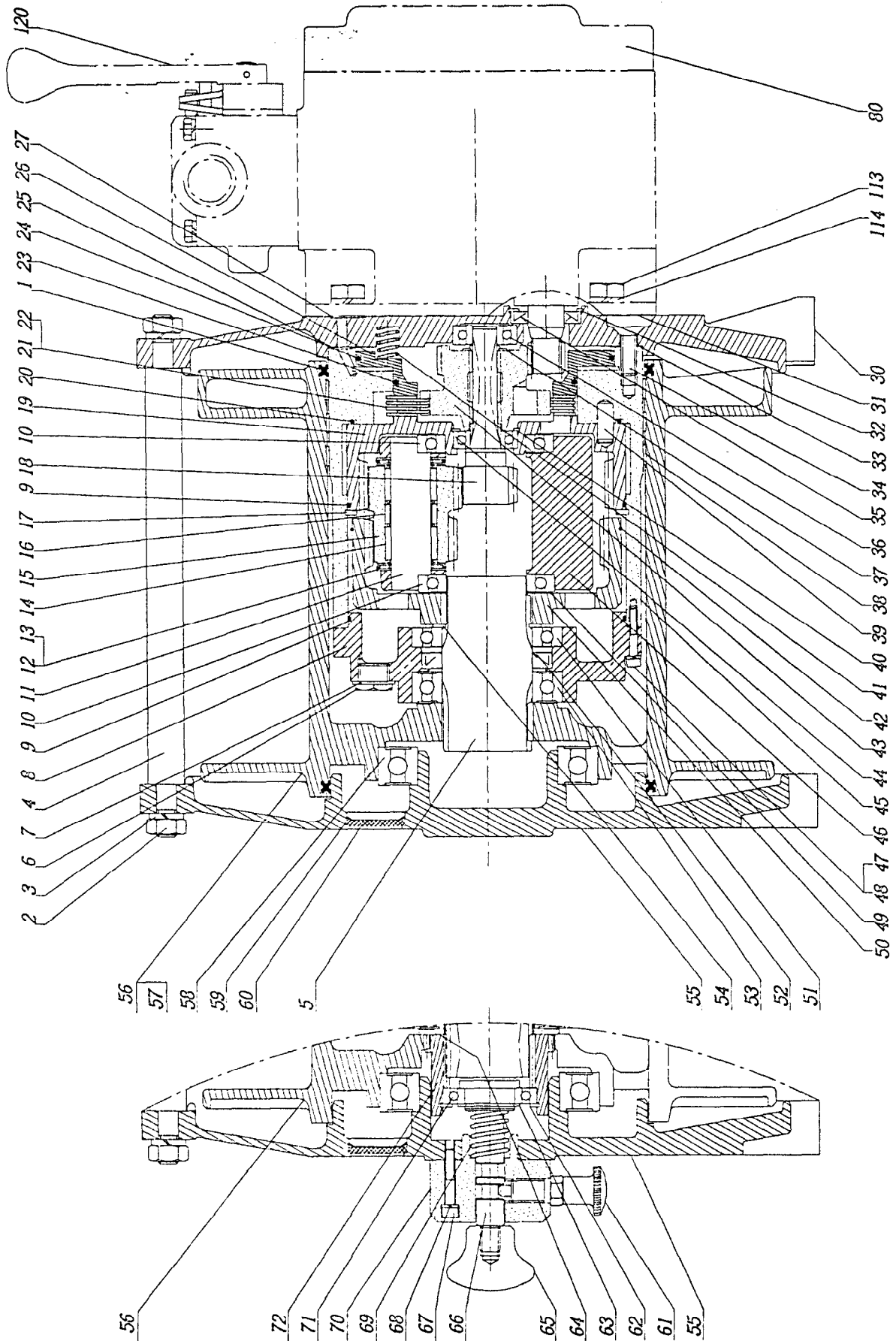

(Dwg. D6310041)

WINCH ASSEMBLY PART LIST

ITEM NO.	DESCRIPTION OF PART	TOTAL QTY	PART NO.
1	Quad-Ring	2	5823-1029
2	Nut	6	4300-0211
3	Lock washer	6	4520-0010
4	Tie rod spacer (short drum) Tie rod spacer (long drum)	3	9631-0008 9631-0052
5	Output shaft	1	9631-0026
• 6	Plug	2	6511-9732
7	Copper joint	2	5840-3431
8	Gear box cover	1	9631-0005
• 9	O' ring	2	5823-1129
10	Bearing	2	5080-0008
11	Planet axle	3	9620-0060
12	Bearing stub	6	5605-3520
13	Stop ring	6	5731-9832
14	Needle bearing	6	5650-2620
15	Planet Gear	3	9620-0075
16	Spacer	3	9619-0024
• 17	Retainer ring	1	4784-7832
18	Shaft spindle	1	9631-0094
19	Fixed annular gear	1	9631-0096
• 20	O' ring	1	5822-1829
21	Friction disc	4	6305-9932
22	Steel disc	3	6306-0032
• 23	O' ring	1	5823-0929
• 24	O' ring	1	5821-2829
• 25	O' ring	1	5821-2529
26	Brake piston	1	9631-0093
• 27	O' ring	1	5822-6629
30	Front end cover	1	9631-0091
• 31	Gasket	1	9631-0118
32	Retainer Ring	1	4770-3035
• 33	Gasket	1	9631-0097

ITEM NO.	DESCRIPTION OF PART	TOTAL QTY	PART NO.
34	Screw	6	4110-2203
• 35	Oil seal	1	5802-0030
36	Bearing	1	5010-0001
• 37	Retainer ring	1	4770-0015
38	Bushing	3	9631-0014
39	Pin	5	4600-0416
• 40	Retainer ring	1	4770-3032
41	Spring	11	6916-5532
• 42	O' ring	1	5820-7129
43	Gear wheel	1	9631-0095
44	Bearing	1	5000-0002
45	Gear box	1	9631-0092
46	Satellite support	1	9620-0010
47	Screw	6	4131-1106
48	Lock washer	6	4520-0004
49	Spring washer	1	6917-2132
50	Output annular gear	1	9620-0031
51	Bearing	1	5080-0009
• 52	Oil seal	1	5801-2130
53	Bearing	1	5005-0009
54	Retainer Ring	1	4770-0045
55	Rear End Cover	1	9631-0003
56	Short Drum (180mm) Long Drum (360mm)	1 1	9631-0001 9631-0050
57	Wire rope wedge	1	9631-0023
58	Bearing	1	5005-0014
• 59	Ring	9	4780-0639
• 60	Exhaust washer	9	6760-0303
80	Air gear motor	1	-
113	screw	4	4100-0201
114	lock Washer	4	4520-0006
120	Air control valve	1	-

Winches with clutch control

Substitute or add the following parts on winch with clutch control

55	Rear End Cover	1	9631-0027
56	Short Drum (180mm) Long Drum (360mm)	1	9631-0028 9631-0051
61	Plunger	1	6628-8132
62	Retainer Ring	1	4770-3047
63	Retainer Ring	1	4770-0025
64	Spacer	1	9631-0007
65	Handle	1	6956-6232

66	Clutch Axle (Short drum) Clutch Axle (long drum)	1	9631-0037 9631-0053
67	Screw	3	4130-7906
68	Washer	3	4520-0005
69	Spring	1	6918-8932
70	Body	1	9618-0060
71	Bearing	1	5080-0005
72	Clutch	1	9631-0029

• Recommended spare

AIR GEAR MOTOR ASSEMBLY DRAWING

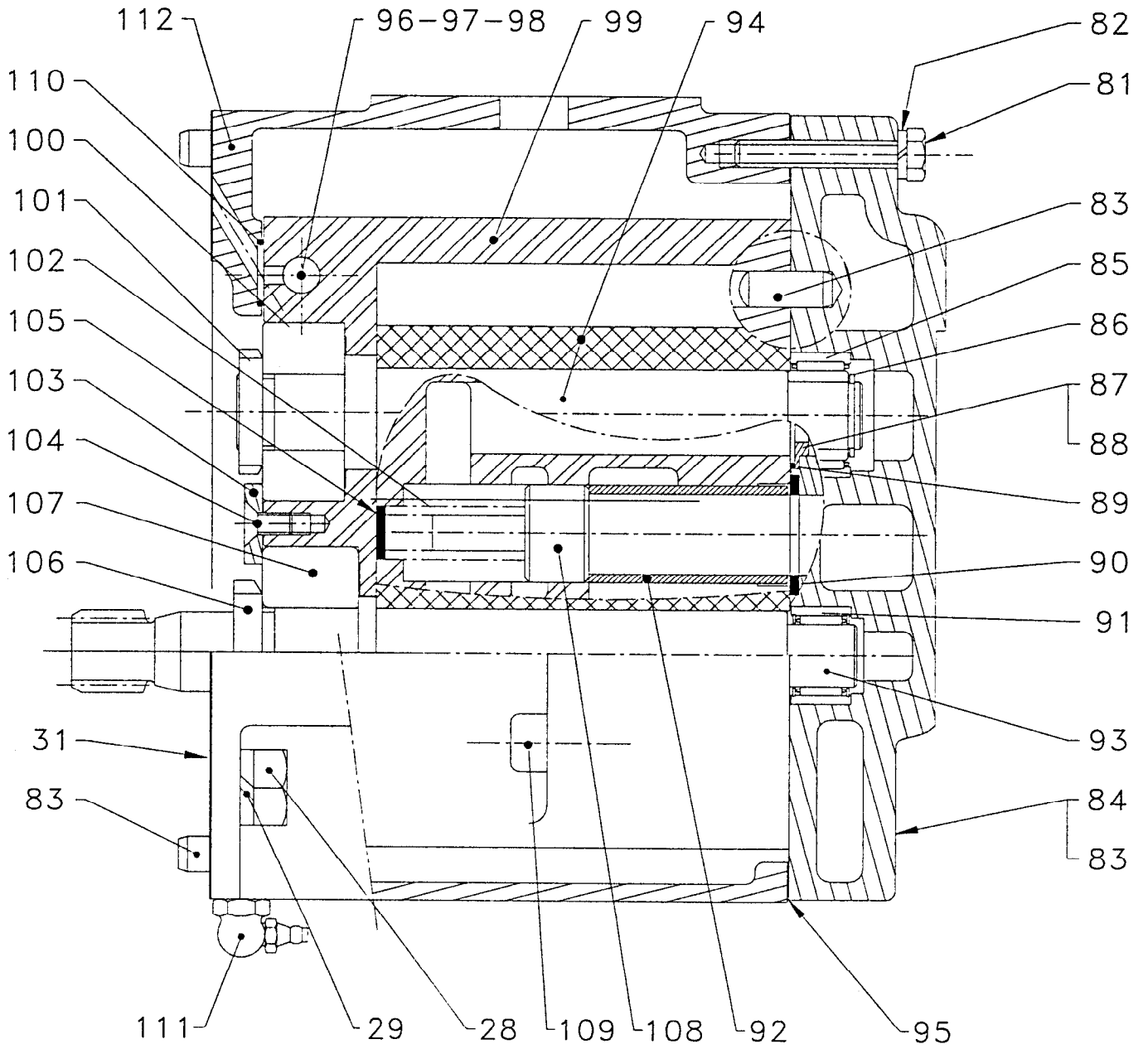

(Dwg. D6310005)

AIR GEAR MOTOR ASSEMBLY PART LIST

ITEM NO.	DESCRIPTION OF PART	TOTAL QTY	PART NO.
31	Gasket	1	9631-0118
80	Motor Ass'y (incl's item 31 & item 81 through 114)		7631-0077
81	Screw	5	4101-9001
82	Lock washer	7	4520-0006
83	Pin	4	4600-0416
84	Motor cover	1	9631-0042
85	Bearing	1	5646-2813
• 86	Shaft segment	1	4783-6732
87	Exhaust washer	1	9620-0045
88	Plug	1	9631-0049
• 89	'O' ring	2	5822-5929
90	Rear stop	2	9620-0069
91	Bearing	1	5649-2213
92	Spacer	1	9631-0018
93	Motor rotor	1	9620-0093
94	Repulsion rotor	1	9620-0026
• 95	Gasket	1	9631-0045
96	Selector stop	1	9609-0223
• 97	Ball	1	6940-1623
• 98	'O' ring	1	5821-2229
99	Motor housing (incl's item 96, 97 and 98)	1	9620-0008
100	Bearing	1	5060-0003
• 101	Nut	1	5700-0003
102	Spring	1	6914-3932
103	Washer	1	9631-0054
104	Screw	1	4110-3403
105	Rear stop	1	9412-0030
• 106	Nut	1	5700-0004
107	Bearing	1	5060-0004
108	Stopper	1	9631-0017
109	Screw	4	4130-2206
• 110	'O' ring	1	5822-1729
111	Greasing nipple	1	6710-2227
112	Motor housing	1	9631-0078
113	Screw	4	4100-0201
114	Lock Washer	4	4520-0006

• Recommended Spare

LEVER CONTROL VALVE ASSEMBLY DRAWING AND PARTS LIST

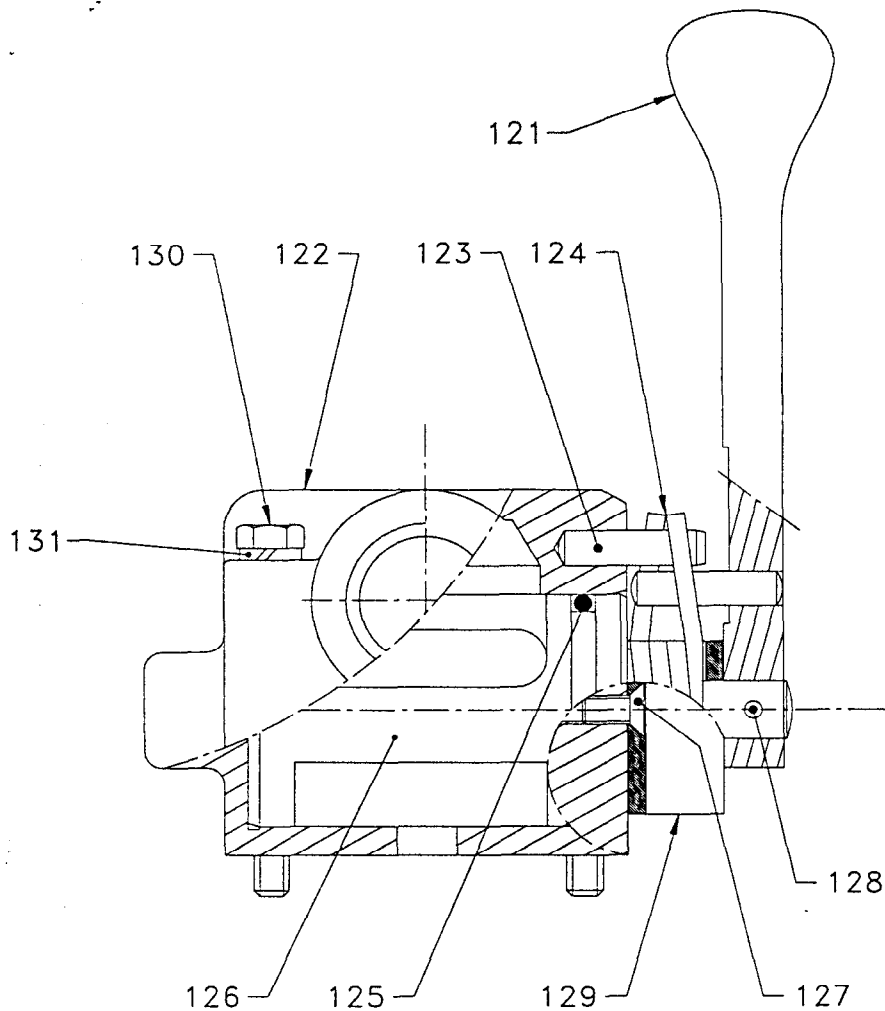

(Dwg. D6310006)

ITEM NO.	DESCRIPTION OF PART	TOTAL QTY	PART NO.
120	Control Valve Ass'y (incl's item 121 through 131)	1	7631-0081
121	Control lever	1	9618-0031
122	Valve housing	1	9631-0021
123	Pin	2	4600-1216
124	Return spring	1	9618-0035
• 125	O'ring	1	5821-0229
• 126	Rotary valve	1	9631-0022
127	Screw	2	4110-3403
128	Pin	1	4650-7220
129	Stop	1	9618-0034
130	Screw HM	4	4101-6601
131	Lock washer	4	4520-0006

• Recommended Spare

CONTROL VALVE ASSEMBLY DRAWING AND PARTS LIST

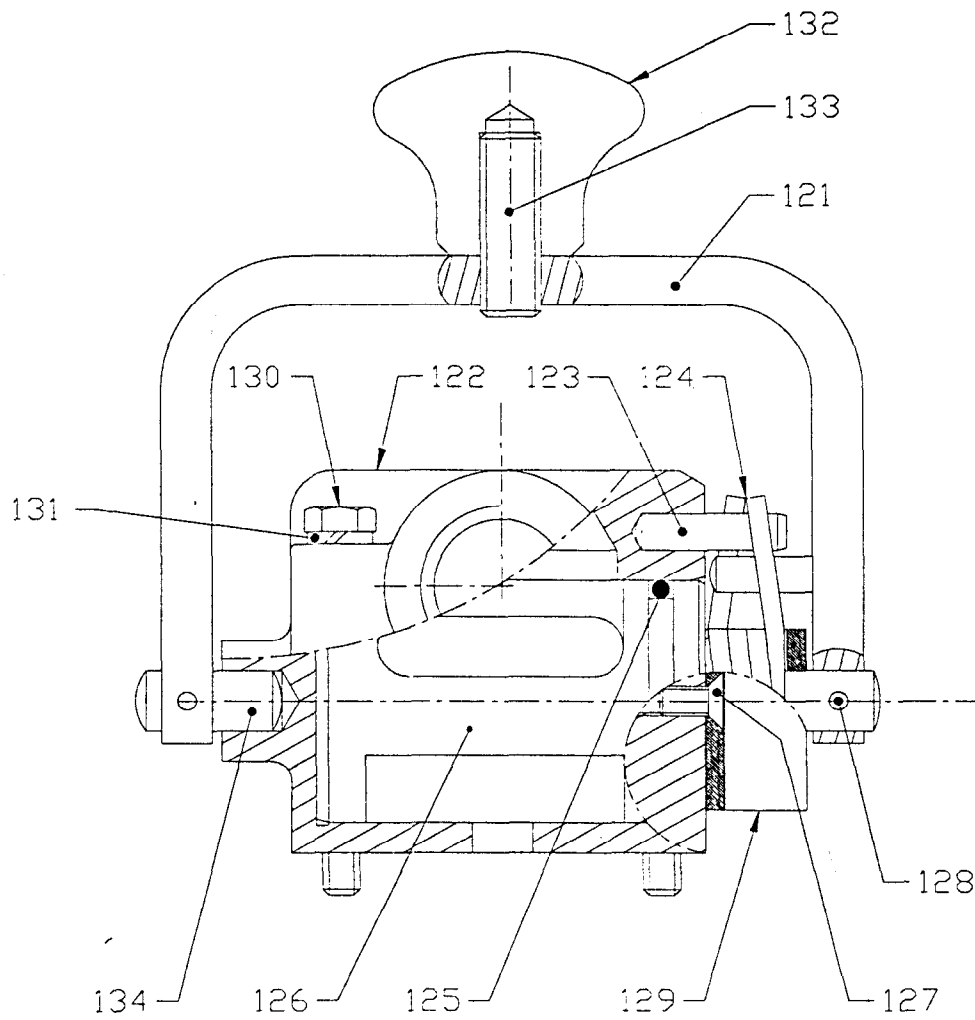

(Dwg. D6310035)

ITEM NO.	DESCRIPTION OF PART	TOTAL QTY	PART NO.
119	Control Valve Ass'y (incl's item 121 through 134)	1	-
121	Control lever	1	9631-0056
122	Valve housing	1	9631-0058
123	Pin	2	4600-1216
124	Return spring	1	9618-0035
• 125	O ring	1	5821-0229
• 126	Rotary valve	1	9631-0022
127	Screw	2	4110-3403
128	Pin	2	4650-7220
129	Stop	1	9618-0034
130	Screw HM	4	4101-6601
131	Lock washer	4	4520-0006
132	Handle	1	6956-6232
133	Setscrew	1	4200-1507
134	Axle	1	9631-0057

• Recommended Spare

OPTIONAL VALVE ASSEMBLY DRAWING AND PARTS LIST

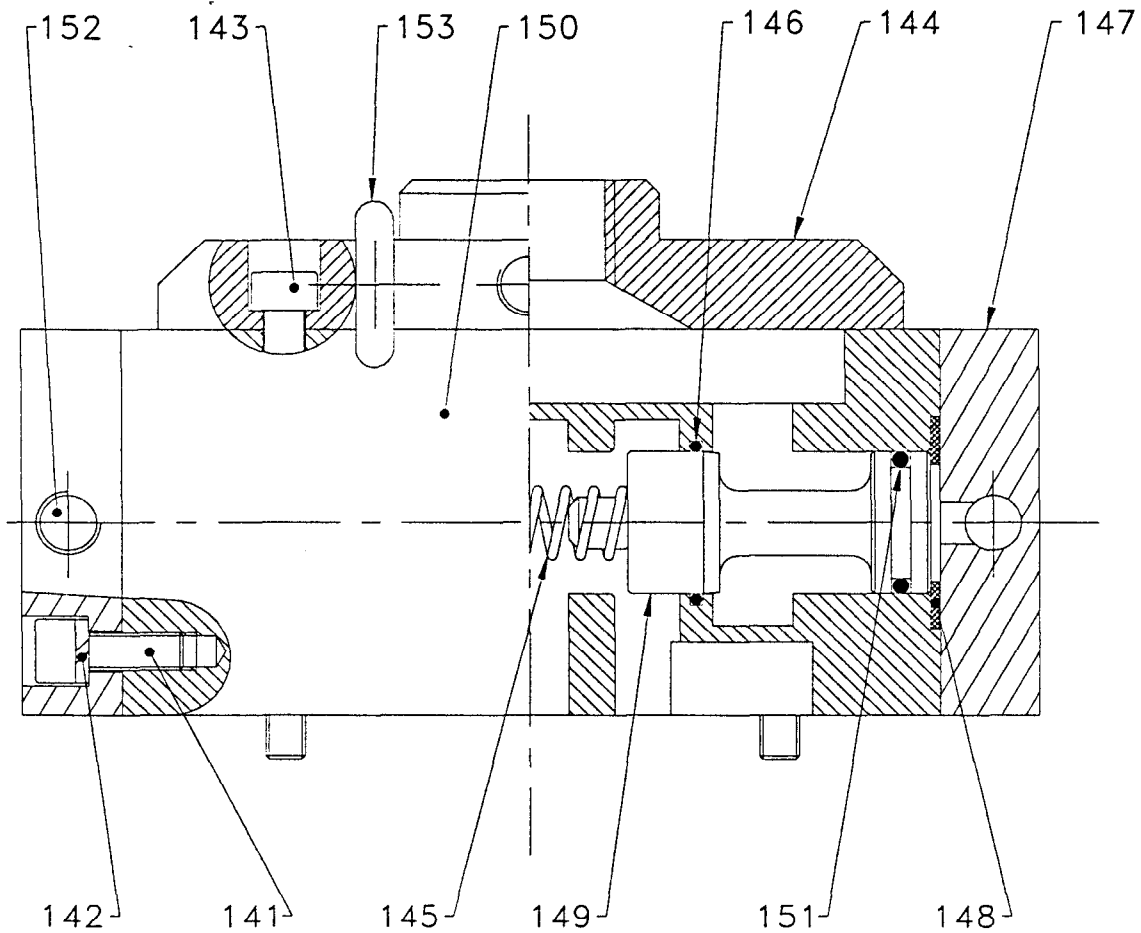

(Dwg. D6310026)

ITEM NO.	DESCRIPTION OF PART	TOTAL QTY	PART NO.
140	Pendant Control Valve Ass'y (incl's item 141 through 153)	1	7617-0010
141	Screw	8	4130-0206
142	Lock washer	8	4520-0006
143	Screw	4	4130-5906
144	Cover	1	9617-0050
145	Return spring	1	9412-0289
• 146	Quad ring	2	5823-2429
147	End cap	2	9617-0049
148	Read stop	2	9412-0031
149	Slide valve	2	9617-0047
150	Valve body	1	9617-0046
• 151	Quad ring	2	5822-9029
152	Fitting	3	6165-2632
153	Lifting Eye	1	6422-2332

• Recommended Spare

REMOTE CONTROL PENDANT ASSEMBLY DRAWING AND PARTS LIST

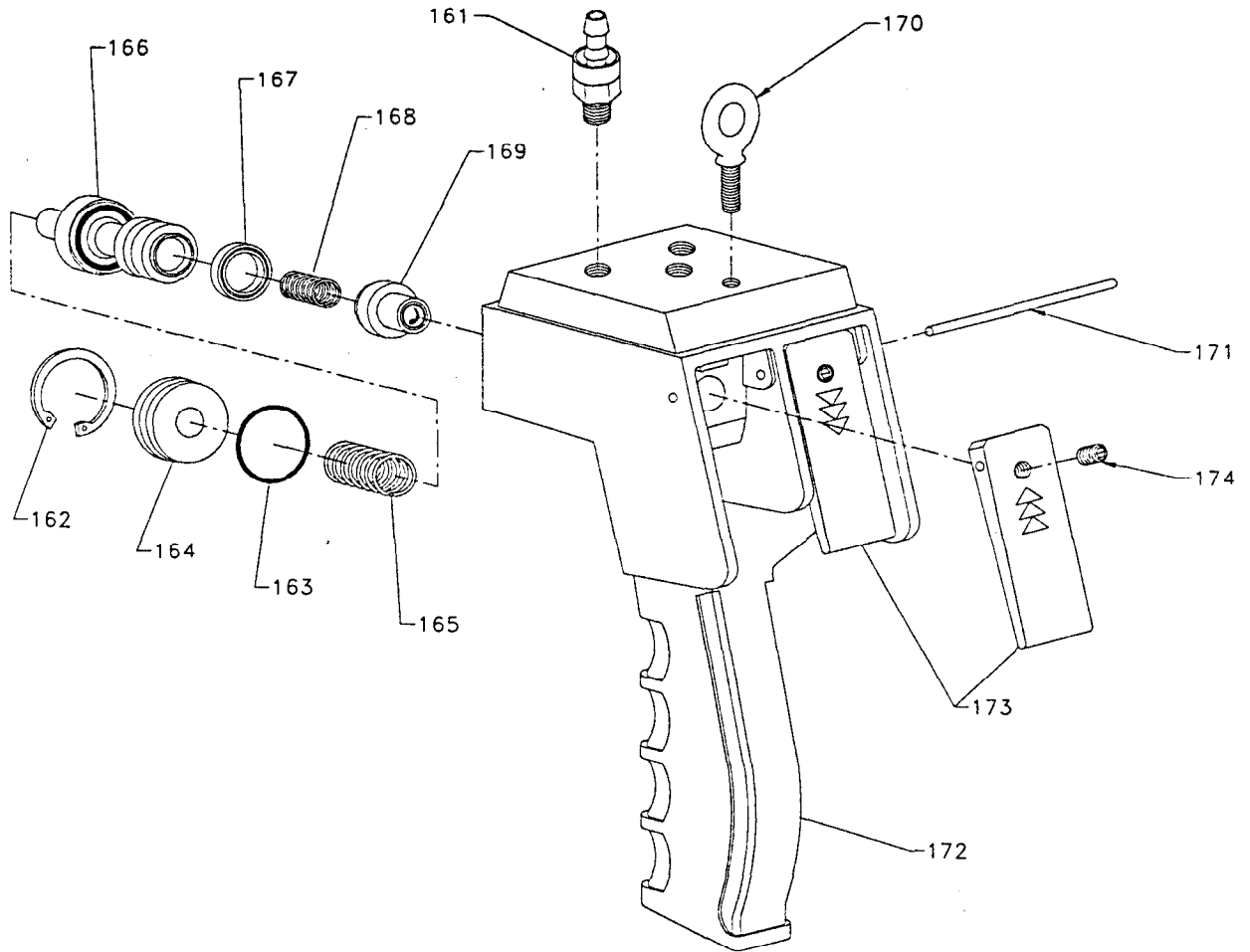

(Dwg.D5790002)

ITEM NO.	DESCRIPTION OF PART	TOTAL QTY	PART NO.
160	Pendant Control Valve Ass'y (incl's item 161 through 174)	1	7579-0038
161	Fitting	3	6165-2632
162	Retainer Ring	2	4770-3028
• 163	'O' Ring	2	5820-3729
164	Rear Cover	2	9579-0037
165	Spring	2	6915-8732
166	Spool (with 'O'Ring crimped)	2	9579-0035
• 167	Quad-ring	2	5823-0229
168	Spring	2	6915-8632
169	Valve Ass'y (with 'O'Ring crimped)	2	9579-0036
170	Lifting Eye	1	6422-2332
• 171	Pin	1	9579-0040
172	Pendant Handle	1	9579-0034
173	Lever	2	9579-0038
174	Setscrew	2	4200-7807

• Recommended Spare

REMOTE CONTROL PENDANT ASSEMBLY DRAWING AND PARTS LIST

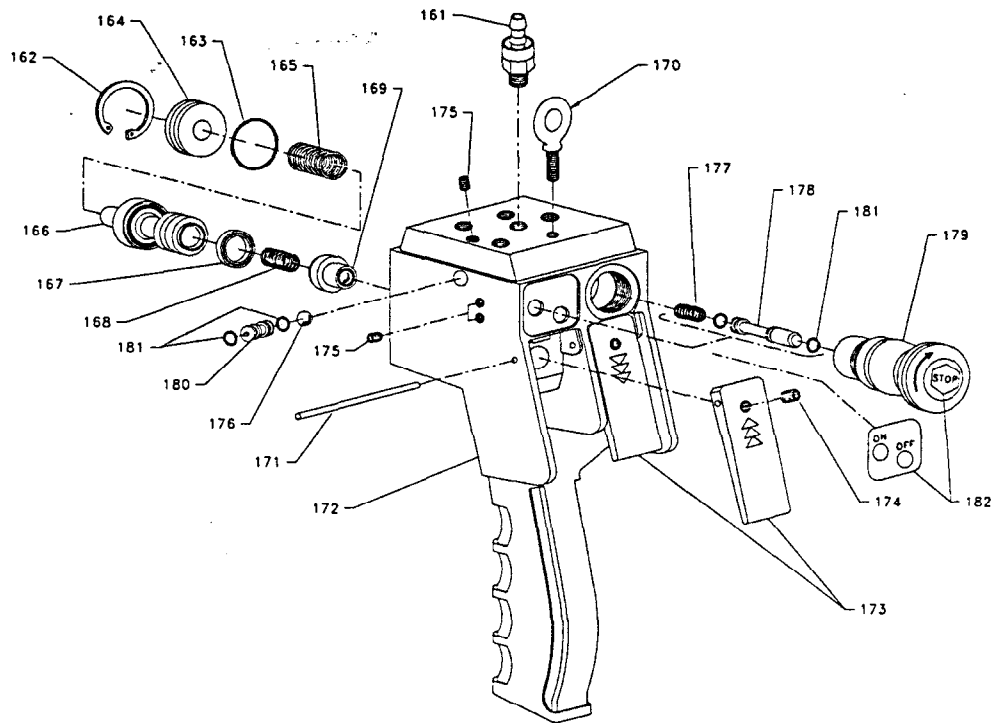

(Dwg.D5790003)

ITEM NO.	DESCRIPTION OF PART	TOTAL QTY	PART NO.
161	Fitting	3	6165-2632
162	Retainer Ring	2	4770-3028
• 163	'O' Ring	2	5820-3729
164	Rear Cover	2	9579-0037
165	Spring	2	6915-8732
166	Spool (with 'O'Ring crimped)	2	9579-0035
• 167	Quad-ring	2	5823-0229
168	Spring	2	6915-8632
169	Valve Ass'y (with 'O'Ring crimped)	2	9579-0036
170	Lifting Eye	1	6422-2332
• 171	Pin	1	9579-0040
172	Pendant Handle	1	9579-0095
173	Lever	2	9579-0038
174	Setscrew	2	4200-7807
175	Setscrew	3	4200-8307
176	Ball	1	6940-1625
177	Spring	3	6911-3941
178	Spool	3	9579-0085
179	Emergency stop button	1	6859-8632
180	Shuttle Valve Stop	1	9579-0098
• 181	'O' Ring	8	5820-9229
182	Label kit	1	9579-0099
183	Pendant control with emergency stop ass'y (incl's item 161 through 182)	1	7579-0071

• Recommended Spare

SHUT-OFF VALVE ASSEMBLY DRAWING AND PARTS LIST

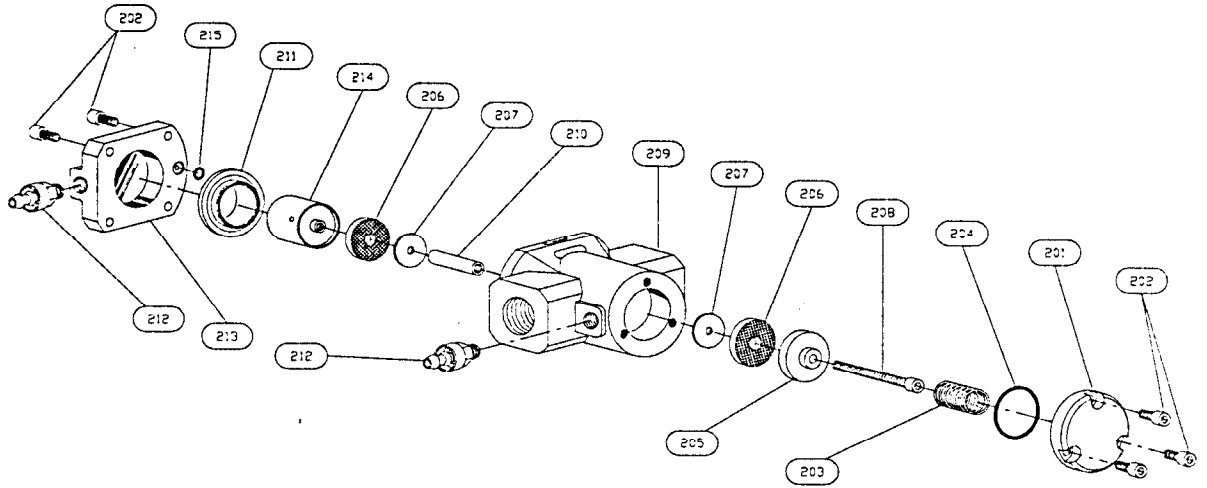

(Dwg.D6170004)

ITEM NO	DESIGNATION OF PART	QTY TOTAL	PART NUMBER
200	Shut-off Valve Assembly (incl's item 201 through 215)	1	7617-0016
201	Cover	1	9617-0059
202	Screw	7	4130-6706
203	Spring	1	6915-8732
• 204	'O' Ring	1	5821-4829
205	Valve Cone	1	9617-0053
• 206	Joint	2	9617-0056
207	Washer	2	4570-0005
208	Screw	1	4130-8206
209	Body	1	9617-0061
210	Distance Ring	1	9617-0055
• 211	Diaphragm	1	6771-6341
212	Fitting	2	6165-2632
213	Cover	1	9617-0052
214	Valve Cone	1	9617-0054
• 215	'O' Ring	1	5820-9229

• Recommended Spare.

EMERGENCY STOP VALVE ASSEMBLY DRAWING AND PARTS LIST

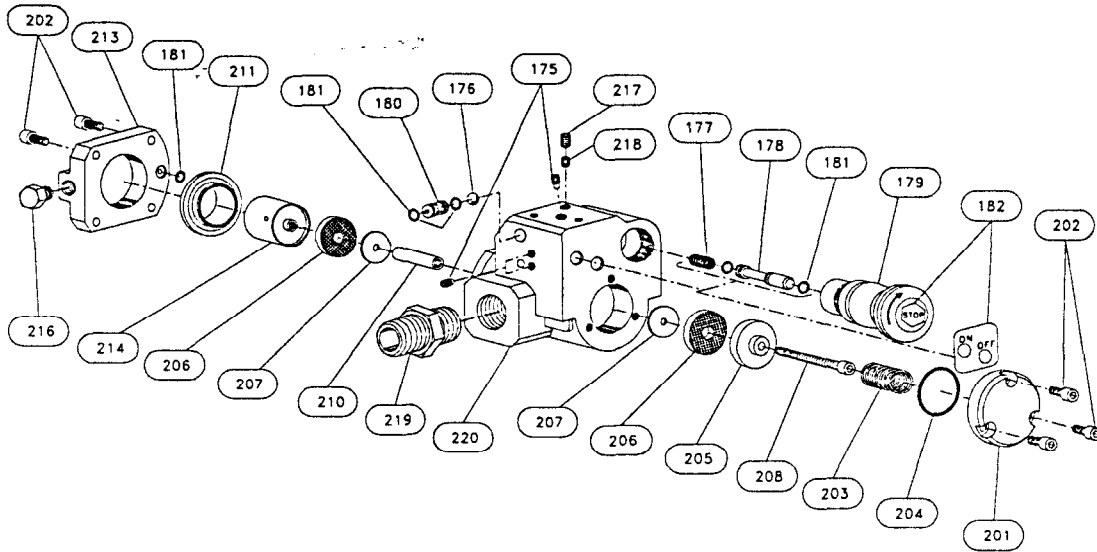

(Dwg.D6170003)

ITEM NO	DESIGNATION OF PART	QTY TOTAL	PART NUMBER
175	Setscrew	3	4200-8207
176	Ball	1	6940-1625
177	Spring	3	6911-3941
178	Spool	3	9579-0085
179	Emergency Stop Bottom	1	6859-8632
180	Shuttle Valve Stop	1	9579-0098
• 181	O' Ring	9	5820-9229
182	Label Kit	1	9579-0099
201	Cover	1	9617-0059
202	Screw	7	4130-6706
203	Spring	1	6915-8732
• 204	O' Ring	1	5821-4829
205	Valve Cone	1	9617-0053
• 206	Joint	2	9617-0056
207	Washer	2	4570-0005
208	Screw	1	4130-8206
210	Distance Ring	1	9617-0055
211	Diaphragm	1	6771-6341
213	Cover	1	9617-0052
214	Valve Cone	1	9617-0054
216	Plug	1	6510-7741
217	Setscrew	1	4200-7407
218	Nozzle	1	9617-0071
219	Nipple	1	6133-0732
220	Body	1	9617-0068
221	Emergency stop Valve Assembly (incl's item 175 through 220)	1	7617-0018

• Recommended Spare.

TORQUE LIMITOR ASSEMBLY DRAWING AND PARTS LIST

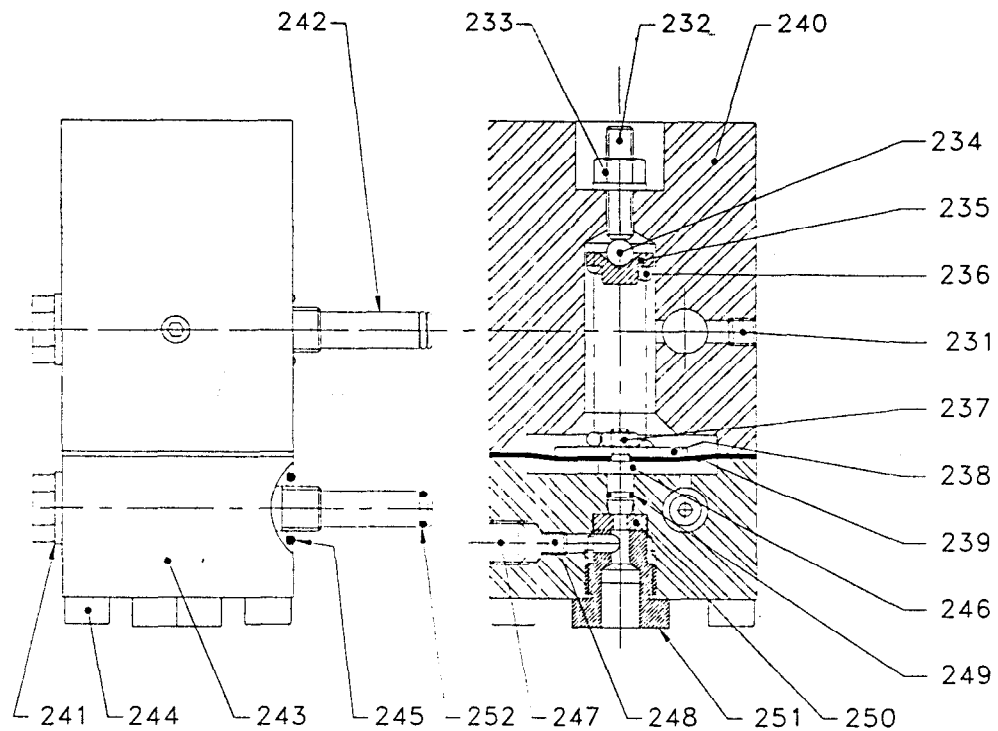

(Dwg.D6360005)

ITEM NO	DESIGNATION OF PART	QTY TOTAL	PART NUMBER
230	Torque limiter Ass'y	1	7636-0005
231	Screw	1	4200-7407
232	Screw	1	4200-1607
233	Nut	1	4300-7811
234	Ball	1	6940-0125
235	Spring Seat	1	9636-0023
• 236	Spring	1	6915-9432
237	Nut	1	4300-1111
238	Washer	1	9636-0019
• 239	Diaphragm	1	9636-0020
240	Cover	1	9636-0015
• 241	Usit-Ring	2	5840-9731
242	Screw	2	9636-0022
243	Body	1	9636-0016
244	Screw	4	4131-4906
• 245	O'Ring	2	5821-0729
246	Valve	1	9636-0017
247	Plug	1	6517-2032
248	Nozzle	1	9617-0071
• 249	O'Ring	1	5822-2329
250	Joint	1	9636-0021
251	Screw	1	9636-0018
• 252	O'Ring	2	5820-9229

• Recommended Spare.

DRUM GUARD ASSEMBLY DRAWING AND PART LIST

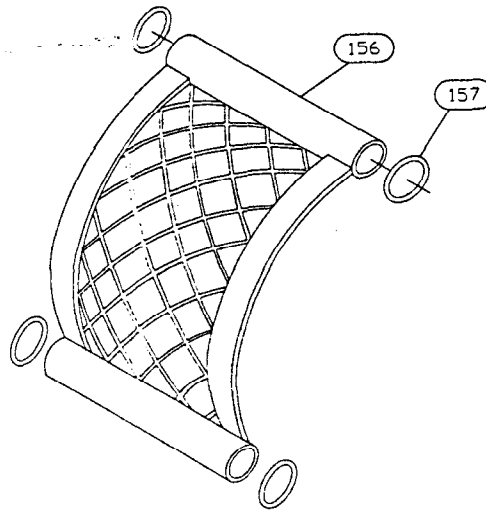

(Dwg.D6310052)

ITEM NO	DESIGNATION OF PART	QTY TOTAL	PART NUMBER	
			SHORT DRUM	LONG DRUM
155	Drum Guard Ass'y (Incl's item 156 and 157)	1	7631-0009	7631-0010
156	Drum Guard	1	9631-0038	9631-0065
157	'O' Ring	4	5821-1529	5822-0929

PARTS ORDERING INFORMATION

The use of replacement parts other than INGERSOLL-RAND Matériel Handling will invalidate the Company's warranty.
For your convenience and future reference it is recommended that the following information be recorded.

Winch Model Number

Winch Serial Number

Date Purchased

When ordering replacement parts, please specify the following:

1. Complete model number and serial number as it appears on the nameplate.
2. Part number and part description as shown in this manual.
3. Quantity required.

The nameplate is located on the winch rear and cover.

NOTICE

- Continuing improvement and advancement of design may cause changes to this winch which are not included in this manual. Manuals are periodically revised to incorporate changes. Always check the manual edition number on the front cover for the latest issue.

Return Goods Policy

INGERSOLL-RAND will not accept returned goods for warranty or service unless prior arrangements have been provided from the location the goods were purchased.

When the life of the winch has expired, it is recommended that the winch be disassembled, degreased and parts separated as to materials so that they may be recycled.

For additional information contact :

Ingersoll-Rand Equipement de Production
Samiia, Douai Operations
 111, avenue Roger Salengro
 59450 Sin-le-Noble - France
 Phone: (33) 3.27.93.08.08
 Fax: (33) 3.27.93.08.00

NOTICE

- Mineral based oils are recyclable, however, some oils such as glycols may be extremely toxic and must be identified and disposed of at an approved waste or disposal site in accordance with all local, state and federal laws and regulations.

HOIST AND WINCH LIMITED WARRANTY

See our general conditions of sales mentioned on our proposal, acknowledgement receipt, invoice.

IR/SAMIIA guarantees the equipment sold and supplied by itself against any defect or flaw in manufacture or operation under the conditions and within the limits hereafter.

- the guarantee is only valid if the customer has satisfied the general obligations of the present contract and, in particular, of settlement.
- the guarantee is strictly limited to IR/SAMIIA equipment. It does extend to supplies and accessories which are not of its manufacture.
- the guarantee does not extend to assemblies or machines in which IR/SAMIIA equipment is incorporated and in particular to the performances of these assemblies or machines.
- when IR/SAMIIA equipment is incorporated into one or other assembly or machine by the customer, he alone is responsible for the adaptation, the choice and the suitability of the IR/SAMIIA equipment. IR/SAMIIA's diagrams, surveys and layouts being given only for guidance, unless there is a special stipulation in the acceptance of order, defined in the acknowledgement of receipt.
- IR/SAMIIA does not guarantee components and accessories it does not sell.

Defects in fitting, adaptation, design, connection and running of the assembly or part of the assembly put together by the customer are not covered by the guarantee. IR/SAMIIA equipment and material as well as the assemblies or machines set up by the customer or by a third party are assumed to be operated and used under the sole control of the customer or third party.

- The duration of the guarantee is for 6 months from the start up of the equipment by the customer. The start up must be made at the latest three months after dispatch of the equipment or its being made available.
- IR/SAMIIA has the right to demand from its customer proof of the date of start up.
- The guarantee period is reduced to half if the equipment is used day and night.
- The length of guarantee is neither prolonged nor interrupted by either amicable or litigious claims by the customer.
- At the expire of this period, the guarantee ceases incontestably.
- The obligations of the IR/SAMIIA guarantee will only come into effect if the customer proves that the defect or flaw appeared during normal operating conditions for this type of material, or in the course of normal use as specified by IR/SAMIIA.

- It does not apply in the event of user's mistake, negligence, imprudence, faulty superintendence or maintenance, inattention to the instructions or directions for use of low quality lubricants.

IR/SAMIIA's liability is disclaimed for all damage brought about by loss or leaks of oil.

- No guarantee applies either for fortuitous incidents or force major, or for wear, replacements or repairs caused by normal use of the equipment.
- The guarantee is restricted to reconditioning in IR/SAMIIA's premises at its expense and as soon as possible the equipment and parts recognised as faulty by its technical or after sales services, which are sent carriage paid and packing free, without there being any claim for damage arising, such as injury to personnel, damage to property other than that covered by the present contract, loss of possession, of production, commercial detriment or loss of profit.
- During the guarantee period, the cost of labour for dismantling and reassembling equipment outside IR/SAMIIA's premises, the cost of moving faulty, replaced or repaired equipment and the travelling and living expenses of IR/SAMIIA's engineers are covered exclusively by the customer.
- In order to obtain the advantages of the guarantee, the customer must advise IR/SAMIIA without delay and in writing of the defects and flaws in his equipment of which he is complained and furnish proof of their genuine nature. He must give IR/SAMIIA or its agents or technicians every facility to verify the defects or flaws and to put them right.
- The guarantee does not apply if the equipment is returned to IR/SAMIIA in a condition other than in which it broke down or if the seal has been removed, or if it has been dismantled, repaired or modified by a third party, or by the user or the customer.
- After having been duly informed of the defect or flaw in its equipment, IR/SAMIIA will put it right as quickly as possible, reserving the right, in certain cases, to modify the whole or part of the equipment so as to meet its obligations.
- The customer agrees that IR/SAMIIA will not be responsible for damage in the event that the customer has not fulfilled one or other of the obligations set out above.
- Parts replaced free of charge remain the property or IR/SAMIIA.
- The guarantee does not apply to wearing parts.

IMPORTANT NOTICE

It is our policy to promote safe delivery of all orders. This shipment has been thoroughly checked, packed and inspected before leaving our plant and receipt for it in good condition has been received from the carrier. Any loss or damage which occurs to this shipment while enroute is not due to any action or conduct of the manufacturer.

VISIBLE LOSS OR DAMAGE

If any of the goods called for on the bill of lading or express receipt are damaged or the quantity is short, do not accept them until the freight or express agent makes an appropriate notation on your freight bill or express receipt.

CONCEALED LOSS OR DAMAGE

When a shipment has been delivered to you in apparent good

condition, but upon opening the crate or container, loss or damage has taken place while in transit, notify the carrier's agent immediately.

DAMAGE CLAIMS

You must file claims for damage with the carrier; It is the transportation company's responsibility to reimburse you for repair or replacement of good damaged in shipment. Claims for loss or damage in shipment must not be deducted from the Ingersoll-Rand invoice, nor should payment of Ingersoll-Rand invoice be withheld awaiting adjustment of such claims as the carrier guarantees safe delivery, You may return products damaged in shipment to us for repair, which services will be for your account and form your basis for claim against the carrier.

United States Office Locations

For Order Entry and Order Status:

**Ingersoll-Rand
Distribution Center**
P.O. Box 618
510 Hester Drive
White House, TN 37188
Phone:(615) 672-0321
Fax: (615) 672-0801

For Technical Support:

**Ingersoll-Rand
Material Handling**
P.O. Box 24046
2724 Sixth Avenue South
Seattle, WA 98124-0046
Phone:(206) 624-0466
Fax: (206) 624-6265

**Regional Sales Offices
Atlanta, GA**
111 Ingersoll-Rand Drive
Chamblee, GA 30341
Phone:(404) 936-6230
Fax: (404) 936-6204

Detroit, MI
23192 Commerce Drive
Farmington Hills, MI 48335
Phone:(810) 476-6677
Fax: (810) 476-6670

Houston, TX
Suite 150
2500 East T.C. Jester
Houston, TX 77008
Phone:(713) 864-3700
Fax: (713) 864-2244

Los Angeles, CA
11909 E. Telegraph Road
P.O. Box 2525
Santa Fe Springs,
CA 900670
Phone:(310) 948-4189
Fax: (310) 948-1828

Milwaukee, WI
12311 W. Silver Sping Dr.
Milwaukee, WI 53225
Phone:(414) 461-0973

Philadelphia, PA
P.O. Box 425
900E. 8th Ave., Suite 103
King of Prussia, PA 19406
Phone:(610) 337-5930
Fax: (610) 337-5912

International

Offices and distributors in principal cities throughout the world. Contact the nearest Ingersoll-Rand office for the name and address of the distributor in your country or write/fax to:

**Ingersoll-Rand
Material Handling**
P.O. Box 24046
2724 Sixth Avenue South
Seattle, WA 98124-0046
USA
Phone:(206) 624-0466
Fax: (206) 624-6265

**Canada
National Sales Office
Regional Warehouse
Toronto, Ontario**
51 Worcester Road
Rexdale, Ontario
M9W 4K2
Phone:(416) 675-5611
Fax: (416) 675-6920
Order Desk
Fax: (416) 674-6549

Regional Sales Offices

Calgary, Alberta
44 Harley Road S.E.
Calgary, Alberta
T2V 3K3
Phone:(403) 252-4180
Fax: (403) 252-4462

Edmonton, Alberta
1340 Weber Center
5555 Calgary Trail N.W.
Edmonton, Alberta
T6H 5G8
Phone:(403) 438-5039
Fax: (403) 437-3145

Montreal, Quebec
3501 St. Charles Blvd.
Kirkland, Quebec
H9H 4S3
Phone:(514) 695-9040
Fax: (514) 695-0963

British Columbia
201-6351 Westminster Hwy
Richmond, B.C.
V7C 5C7
Phone:(604) 278-0459
Fax: (604) 278-1254

**Latin America Operations
Ingersoll-Rand
Production Equipment
Group**
730 N.W. 107 Avenue
Suite 300, Miami, FL
33172-3107
Phone:(305) 559-0500
Fax: (305) 559-7505

**Europe, Middle East and
Africa
Ingersoll-Rand Equipements
de Production S.A.**
111, avenue Roger Salengro
59450 Sin le Noble, France
Phone:(33) 3.27.93.08.08
Fax: (33) 3.27.93.08.00

**Asia - Pacific Operations
Ingersoll-Rand (Japan) Ltd.**
Kowa Bldg. No. 17
2-7 Nishi-Azabu 1-chome
Minato-ku, Tokyo 106,
Japan
Phone:(03)3403-0641/7
Fax: 81 3 3401-2049

**Russia
Ingersoll-Rand Company
World Trade Center
Office 1101**
Krasnopresnenskaya Nab.12
Moscow, Russia 123610