

OPERATION AND MAINTENANCE MANUAL

FOR THE

AIR POWERED MAN-RIDING WINCH

THE MANRIDER 0.5 TON

FG05 MR 19

READ THIS MANUAL BEFORE USING THESE PRODUCT. This manual contains important safety, installation, operation and maintenance information. Make this manual available to all persons responsible for the operation, installation and maintenance of these product.

WARNING

"As regards man-riding winches, it is the responsibility of the owner or user of the winch to determine whether the winch conforms with local regulations for personel use"

Always operate, inspect and maintain this winch in accordance with National Standards Safety Code of the country where the material is used and respect the other applicable safety codes and particular regulations.

Refer all communications to the nearest INGERSOLL-RAND Material Handling Products Office or Distributor.

Form SAM0010
Edition 6
JUNE 1996

INGERSOLL-RAND
MATERIAL HANDLING

SUMMARY

DESCRIPTION	N° DOCUMENT	FOLIOS
A - SAFETY INFORMATION AND TRAINING Danger, Warning, Caution and Notice	92.04.39	3/18 - 4/18
B - SAFE OPERATING INSTRUCTIONS	92.04.39	4/18
C - LABELLING - MARKING	92.04.39	5/18
D - SPECIFICATIONS Technical sheet Description Accessories-Options Air connection drawing	92.04.39 92.04.39 92.04.39 92.04.39 92.04.39	6/18 7/18 8/18 8/19 - 9/18 9/18
E - INSTALLATION Mounting Wire Rope Air Supply Motor Initial Operating Checks	92.04.39 92.04.39 92.04.39 92.04.39 92.04.39	10/18 10/18 - 11/18 11/18 - 12/18 12/18 12/18
F - OPERATION Controls	92.04.39	12/18 - 13/18
G - LUBRICATION Wire Rope Reduction Gear Assembly Seals and Bearings	92.04.39 92.04.39 92.04.39	13/18 13/18 13/18
H - INSPECTION Records and Reports Frequent Inspection Periodic Inspection Winches not in Regular Use	92.04.39 92.04.39 92.04.39 92.04.39	14/18 14/18 14/18 - 15/18 15/18
I - TROUBLE SHOOTING	92.04.39	16/18
J - MAINTENANCE General Disassembly	92.04.39	17/18
K - PARTS Plan of the external band brake List of parts of the external band brake Disassembly instructions (direct brake on drum) Inspection and repair Assembly instructions (direct brake on drum) Winch assembly drawing Winch assembly part list Disassembly instructions (winch) Cleaning, inspection and repair Assembly instructions (winch) Air control valve drawing and part list Disassembly instructions (air control valve) Assembly instructions (air control valve)	92.04.39 92.04.08 92.04.08 92.04.08 92.04.08 92.04.08 96.06.01 96.06.01 96.06.05 96.06.05 96.06.05 96.06.03 96.06.07 96.06.07	18/18 1/6 2/6 - 3/6 4/6 - 5/6 5/6 6/6 1/3 2/3 - 3/3 1/4 - 2/4 2/4 3/4 - 4/4 1/1 1/1 1/1

INGERSOLL-RAND
MATERIAL HANDLING

AIR POWERED MAN-RIDING WINCH

NUMERO DE NOMENCLATURE

7615-8020

Copyright 1996
Ingersoll-Rand Company
All Rights Reserved

FG05 MR 19

NUMERO DU DOCUMENT

92.04.39 12/18

LE CHEF DU BUREAU D'ETUDES

DESCRIPTION	N° DOCUMENT	FOLIOS
Air motor drawing	96.06.02	1/2
Air motor part list	96.06.02	2/2
Disassembly instructions (air motor)	96.06.06	1/1
Assembly, instructions (air motor)	96.06.06	1/1
Plan of air accessories and option	96.06.04	1/2
List of parts of air accessories	96.06.04	2/2
Drum guard kit	93.03.02	1/1
Option air powered limit switch "man-riding winch" (function - description - adjusting)	95.10.20	1/2
Option air powered limit switch "man-riding winch" (drawing and parts list)	95.10.20	2/2
Option torque limiter (drawing and parts list)	95.10.19	1/1
Option emergency stop "man-riding winch" (drawing)	95.10.18	1/2
Option emergency stop "man-riding winch" (parts list)	95.10.18	2/2
L - PARTS ORDERING INFORMATION	92.04.42	1/2
M - GUARANTEE	92.04.42	1/2 - 2/2

INGERSOLL-RAND
MATERIAL HANDLING

AIR POWERED MAN-RIDING WINCH

NUMERO DE NOMENCLATURE

FG05 MR 19

NUMERO DU DOCUMENT

9,2,0,4,3,9 | A | 3/18

Copyright 1996
Ingersoll-Rand Company
All Rights Reserved

LE CHEF DU BUREAU D'ETUDES

A - SAFETY INFORMATION AND TRAINING

This manual provides important information for all personnel involved with the safe installation, operation and proper maintenance of this product. Even if you feel you are familiar with this or similar equipment, you must read understand this manual before operating the product. Training must be done by a qualified person to any personnel involved with an air powered man-riding winch

Danger, Warning, Caution and Notice

Throughout this manual there are steps and procedures which, if not followed, may result in a hazard. The following signal words are used to identify the level of potential hazard.

DANGER

Danger is used to indicate the presence of a hazard which *will* cause *severe* personal injury, death, or substantial property damage if the warning is ignored.

WARNING

Warning is used to indicate the presence of a hazard which *can* cause *severe* personal injury, death, or substantial property damage if the warning is ignored.

CAUTION

Caution is used to indicate the presence of a hazard which *will* or *can* cause *minor* personal injury or property damage if the warning is ignored.

NOTICE

Notice is used to notify people of installation, operation, or maintenance information which is important but not hazard-related.

CAUTION

"MAN-LIFTING with this winch is STRICTLY LIMITED to off-shore marine applications specifically approved by maritime regulatory bodies. Regulatory bodies, not manufacturer, have determined suitable use. DO NOT USE FOR MAN-LIFTING applications not specifically approved by regulatory bodies.

The use of a winch to lower, lift or suspend personnel should be permitted only when other means of reaching the worksite, such as ladders, stairways, aerial (bucket-type) lifts or scaffolds, are not feasible because of site conditions.

Presently MANRIDER winches are available built to specifications published by :
Det Norske Veritas : Winches type approved and/or certified by Det norske Veritas (DNV) to meet Norwegian Maritime Directorate (NMD) or Norwegian Petroleum Directorate (NPD) requirements.

In furnishing customers MANRIDER winches, Ingersoll-Rand does not warrant the suitability of these winches for any particular use. It is the owner and user's responsibility to determine the suitability of a MANRIDER winch for a particular application. Further, it is the owner and user's responsibility to check and satisfy all local, state, federal and country requirements pertaining to the lifting and lowering of persons.

WARNING

Many agencies require additional redundant safety devices on winches that Ingersoll-Rand does not furnish. Additional devices are often required to bring the system up to elevator code standards.

Winches manufactured by Ingersoll-Rand as an approved MANRIDER to DEn and/or NMD/NPD requirements are furnished with limitations ; approval for use in Man-Riding applications automatically terminates for any of the following reasons :

INGERSOLL-RAND
MATERIAL HANDLING

Copyright 1996
Ingersoll-Rand Company
All Rights Reserved

AIR POWERED MAN-RIDING WINCH

FG05 MR 19

NUMERO DE NOMENCLATURE

NUMERO DU DOCUMENT

92.04.39 | A | 4/8

LE CHEF DU BUREAU D'ETUDES

- 1 - Winch does not meet other applicable codes or standards.
- 2 - Winch is not part of an approved system.
- 3 - Winch is not properly maintained in a new condition with all parts intact and properly adjusted.
- 4 - Winch is used in applications not approved by codes and regulations, or applications inconsistent with manufacturer's operating and maintenance manual.
- 5 - Changes in DEN or NMD/NPD standards or regulations after Ingersoll-Rand's initial shipment of the product.
- 6 - More than one winch is used to attach to a common load.

WARNING

Be sure to check all regulations, local, state, federal and country, that may apply to the use of a winch or winch system for lifting and lowering people before using a MANRIDER winch.

- 7 - The personnel platform shall be designed by a properly qualified engineer competent in this area.

NOTICE

Using other than genuine Ingersoll-Rand Material Handling parts will result in the void of warranty.

B - SAFE OPERATING INSTRUCTIONS

WARNING

Failure to follow these rules will result in termination of all applicable warranties. Ingersoll-Rand assumes no liability for any loss or damage resulting from operation of MANRIDER winches if these operating instructions are not followed.

- 1 - Winch operator must be in a position to always see the personnel from transfer point to landing area.
- 2 - Personnel operating the winch or being transferred are to have sufficient instruction/training concerning that operation before any movement takes place.
- 3 - Lifting and lowering of personnel should be carried out above the open sea whenever possible. All personnel should wear life jackets approved by the appropriate regulatory agency and a standby vessel should be in the vicinity of the transfer.
- 4 - Hoisting of personnel by means of a winch should only take place when other means of accomplishing this work are not practical.
- 5 - The winch installation must be specially arranged and accepted for personnel handling.
- 6 - Prior to any personnel movement, the entire system should be inspected by the person in charge. It is that individual's responsibility to instruct and appoint the winch operator.
- 7 - The lifting apparatus (basket, etc...) shall be inspected and certified for personnel lifting prior to use.
- 8 - Do not operate without a surveyor's site approval.
- 9 - Do not overload.
- 10 - Do not operate without testing. (See "Inspection and Testing" procedures)
- 11 - Do not operate winch in a damaged condition.
- 12 - Do not operate winch that has not been properly maintained or equipped.
- 13 - Do not attach winch to unsafe foundation. All bolts and foundations for winch attachment should have a higher load carrying capacity than the wire rope on the winch.
- 14 - Do not operate winch with any personnel near the line of force or capable of coming into contact with moving parts.
- 15 - All signs and warning notices must be posted permanently on the winch.
- 16 - Always maintain three or more wraps of wire rope on the drum.
- 17 - Never leave an unattended load suspended.
- 18 - Wire rope must spool off drum from the top away from the operator.

INGERSOLL-RAND
MATERIAL HANDLING

AIR POWERED MAN-RIDING WINCH

NUMERO DE NOMENCLATURE

Copyright 1996
Ingersoll-Rand Company
All Rights Reserved

FG05 MR 19

NUMERO DU DOCUMENT

92,04-39 | A | 5/18

LE CHEF DU BUREAU D'ETUDES

C - LABELLING - MARKING

The maximal lifting rated capacity of the winch is noticed on one part of the winch.

On every air powered man-riding winch a sheet is clinched as this model :

INGERSOLL-RAND		THE MANRIDER	
MATERIAL HANDLING		AIR WINCH	
MODEL NUMBER	_____	CODE	_____
SERIAL NUMBER	_____	TRACEABILITY	_____
MAN AND UTILITY LIFT SWL	_____	KN at _____	m/mn at _____ layer
AIR PRESS	_____ bar	AIR FLOW	_____ m ³ /mn
DRUM SIZE mm	_____	Barrel Dia.	_____
		Flange Dia.	_____ Lgth.
DRUM CAPACITY			
ROPE Dia. mm	_____	RATING _____	m STORAGE _____ m

Each winch is supplied from the factory with the warning label shown. If the label is not attached to your unit, order a new label and install it. See the parts list for the part number. Read and obey all warnings and other safety information attached to this winch. Label may not be shown actual size :

MAN-RIDING WINCH
WARNING

Failure to follow these warnings may result in death, severe injury or property damage :

. Do not operate this winch before reading operation and maintenance manual.

. It is responsibility of the owner or user to determine whether the winch conforms with local regulations for personnel use

. Do not lift more than rated load

. Do not allow less than three wraps of wire rope to remain on drum at all times.

. Do not operate a damaged or malfunctioning winch.

. Do not remove or obscure warning labels

INGERSOLL-RAND
Material Handling

INGERSOLL-RAND
MATERIAL HANDLING

AIR POWERED MAN-RIDING WINCH

NUMERO DE NOMENCLATURE

FG05 MR 19

NUMERO DU DOCUMENT

19,2,0,4,39 | A | 618 |

Copyright 1996
Ingersoll-Rand Company
All Rights Reserved

LE CHEF DU BUREAU D'ETUDES

D - SPECIFICATIONS

The MANRIDER™

Air powered personnel lifting winch, 0.5 & 1 metric ton capacity

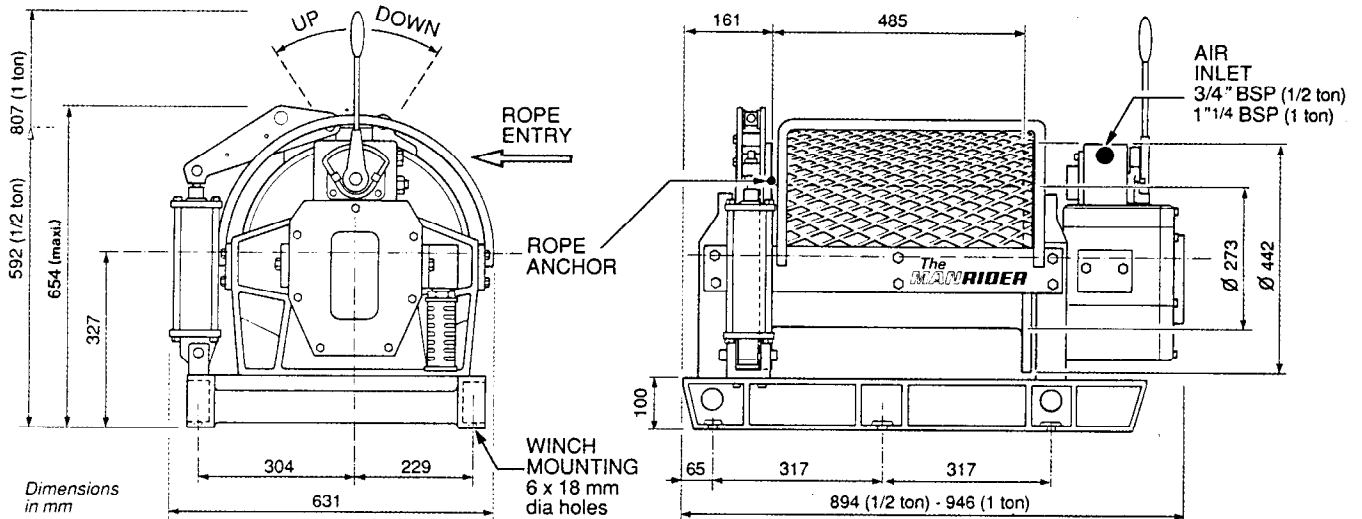

Specifications

Model No.	FG05MR19	FG1MR19
Rated working load (metric ton) (1)	0.5	1
Motor power (hp)	3	6
Working pressure (bar)	6.3	6.3
Average hoisting speed (m/min) (2)	0 to 24	0 to 24
Air consumption (m ³ /min)	0 to 3.5	0 to 7
Weight without rope (kg)	300	340
Rope diameter (mm)	13	13

1) On 4th layer with 13 mm rope diameter
2) At rated load

Wire rope specifications & drum capacity

Recommended wire rope size (mm)	13	
Breaking load (metric ton)	11.1	15.3
Rope grade (kg/mm ²)	180	220
Cumulative rope capacity (m)	1st layer	31
	2nd layer	65
	3rd layer	102
	4th layer	142
	5th layer	185
	6th layer	230

Performance at 6.3 bar (90 PSI)

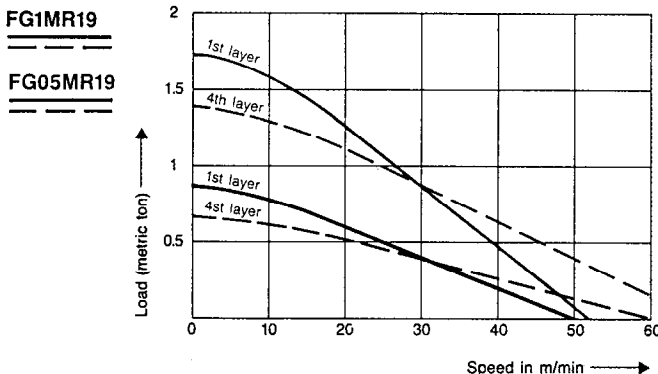

Additional options/accessories available

- Filter/oiler and pressure regulators
- Pneumatic overload protection acting on the drum brake when exceeding the rated overload
- Bottom limit switch (stops when last 3 wraps are reached)
- Top limit (prevents overwinding)
- Grooved drum
- Emergency stop valve mounted in air line
- Wire rope and accessories

- Material certificates according to DIN 50049
- Type approval certificates

INGERSOLL-RAND®
MATERIAL HANDLING

Nothing contained within this leaflet is intended to extend any warranty or representation, expressed or implied, regarding the products described herein. Any such warranties or other terms or conditions of sale of products shall be in accordance with Ingersoll-Rand's standard terms and conditions of sale for such products, which are available upon request.

E 191001A - Printed in France

Distributor

INGERSOLL-RAND
MATERIAL HANDLING

Copyright 1996
Ingersoll-Rand Company
All Rights Reserved

AIR POWERED MAN-RIDING WINCH

FG05 MR 19

NUMERO DE NOMENCLATURE

NUMERO DU DOCUMENT

9,2,04,39 | A | 8/8

LE CHEF DU BUREAU D'ETUDES

DESCRIPTION

The "Manrider" winches have been designed and built for the "oil and offshore" industry and more specifically to conform with specifications asked for the Norwegian Oil Ministry and the British Department of Energy.

There are no norms for the use of "Manrider" except those currently demanded by the offshore industry. Thus it is the responsibility of the user to determine the adaptability of this material for specific use and to ensure that it conforms to any rules which may be applicable.

Nomenclature of winch : FEM 4 M (ISO M 7) - Safety load of stress FEM 2 (ISO L 2)

This winch is supplied with a Tracability list for the main parts which are under load together with a DNV "Type Approval Certificate" S945.

Construction : the winch has 4 constituent parts designed for the most difficult tasks :

- a) an engine block
- b) a brake-control reducer block within the drum
- c) a frame constructed mainly of two strutted flanges
- d) a drum

Motor : Air motor with two ways of rotation

Reducer : rotary gear system with gears of specially treated high grade steel mounted on roller bearings. This mechanism is enclosed within the winch drum forming the oil sump.

Brake : multidisc in large oil bath ensuring constant control of the load when lowering. It works by decompression thus ensuring automatic function of the brake in case of air failure. This "wet brake" ensures a constant level of braking and is unaffected by exterior conditions.

Brake : direct on to a large drum ensuring constant control of the load while lifting or lowering. It works by decompression thus ensuring automatic function of the brake in case of air failure.

Drum : made of steel with cable fixing by a wedged box.

Frame : made of two strutted flanges.

Air supply to motor : by one hole ϕ 3/4" BSP located on the distributor

Control : the winch is controlled by a single lever on the winch distributor which allows any speed variation determined by the operator. This lever returns automatically to zero thus stopping the load in the event of failure of the operator.

Chassis skid : made of welded steel with 6 18 diameter fixing holes and 4 40 diameter holes for handling.

Anti-spin device : a free wheel within the multidisc brake. This prevents any slippage of the drum during the release of the air-compressed overload device.

* protecting wire casing fixed on to the distance pieces

Accessories :

DESIGNATION	CODE	CPN
oil atomizer 3/4" G BSP	3397-1909	38530879
filter-lubricator set (F - L) ϕ 3/4" G BSP	3999-0067	38529699
filter-regulator lubricator set (F - R - L) ϕ 3/4" G BSP	3999-0066	38529681
13 mm diameter anti-giratory cable (breaking load 111 KN at 1770 N/mm ²)	6974-0013	38531000
13mm diameter high resistance cable (breaking load 153 KN at 2160 N/mm ²)	6975-0013	38531018
thimble sleeved loop, fixed at end of cable	6972-9999	38520672
safety hook fixed onto thimble-sleeved loop	6612-7932	38520664

Options :

- * manual spindle locking of drum
- * marine paint protection
- * Lifting and lowering limit switch (detecting device with at least 3 coils)
- * load lowering device in case of power failure
- * emergency stop system
- * Air overload protection : device acting directly on the air feeding of the external band brake.
Adjustment $SWL < F4 < 1,3 SWL$

AIR CONNECTION DRAWING

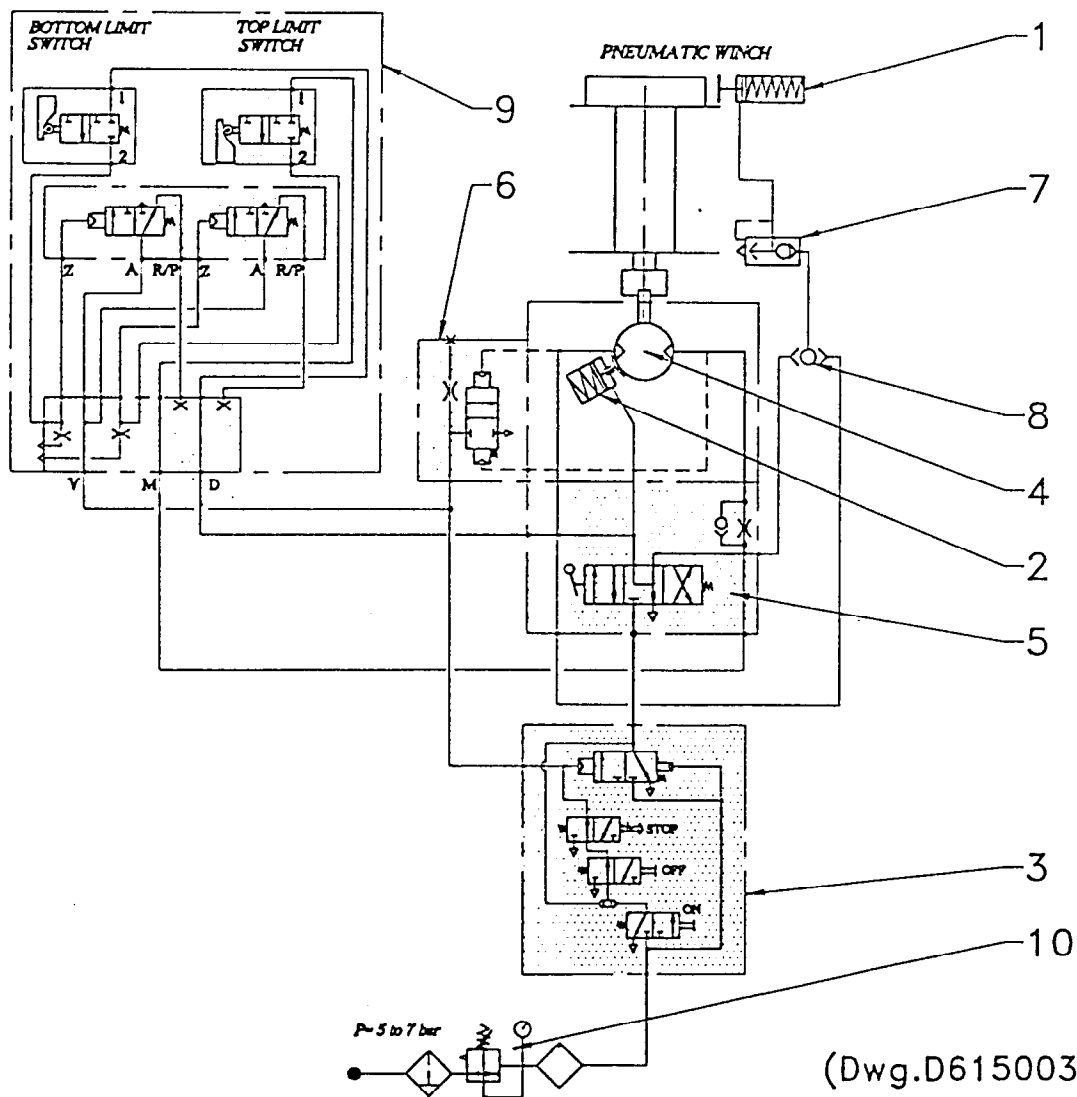

(Dwg.D6150030)

IDENTIFICATION OF COMPONENTS

- | | |
|--|--|
| 1 - Direct band brake on drum | 6 - Torque limiter option |
| 2 - Multidisc brake on shaft motor | 7 - Fast exhaust valve |
| 3 - Emergency stop option | 8 - Circuit selector |
| 4 - Air-powered motor with reversible horizontal motor | 9 - Air limit switch option |
| 5 - Air control valve with stop-load gasket | 10 - Option : FRL block \varnothing 3/4" G |

E - INSTALLATION

Prior to installing the winch, carefully inspect it for possible shipping damage.

CAUTION

Owner and users are advised to examine specific, load or other regulations, which may apply to a particular type of use of this product before installing or putting winch to use.

Mounting

- 1 - If product is to be mounted in one position be sure the mounting surface is even and of sufficient strength to handle the rated load and prevent possible binding of the winch.
- 2 - Make sure the mounting surface is flat to within 1/32 inch (0,8 mm). Shim if necessary
- 3 - Mounting bolts must be 5/8 in. (16 mm) diameter, Grade 8.8 (classe 8.8) or better. Use self-locking nuts or nuts with lockwashers.
- 4 - Torque mounting bolts evenly.
- 5 - Maintain a fleet angle between the sheave and winch of no more than 1-1/2 degrees. For every inch of drum length, the lead sheave must be at least 1.6 feet (0.5 m) from the drum.
- 6 - Do not weld to any part of the winch

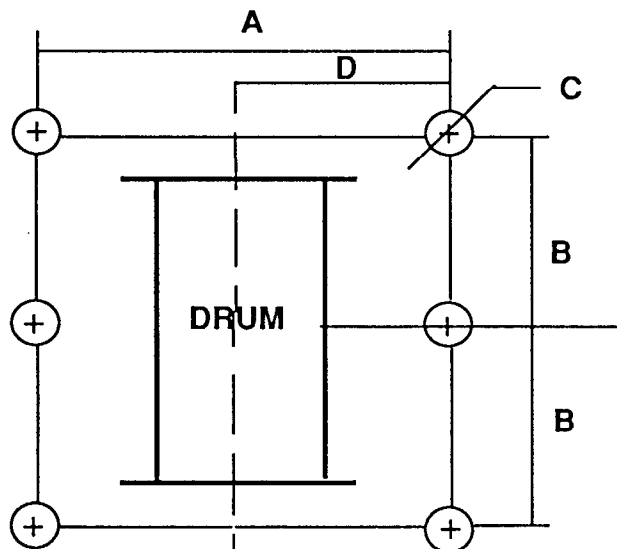

Bolt Hole Dimensions (SKID FRAME)

- "A" 29.99 in. (533 mm)
- "B" 12.48 in. (317 mm)
- "C" 0.71 in. (18 mm)
- "D" 9.02 in. (229 mm)

Wire rope

CAUTION

- Maintain at least 3 wraps of wire rope on the drum at all times.
- Install the wire rope to come off the drum in an overwind position as indicated on the direction of rotation tag.

Wire rope selection

Consult a reputable wire rope manufacturer or distributor for assistance in selecting the appropriate type size of wire rope and, where necessary, a protective coating. Use a wire rope which provides an adequate safety factor to handle the actual working load and meets all applicable industry, trade association, state and local regulations.

**INGERSOLL-RAND
MATERIAL HANDLING**

AIR POWERED MAN-RIDING WINCH

NUMERO DE NOMENCLATURE

FG05 MR 19

NUMERO DU DOCUMENT

Copyright 1996
Ingersoll-Rand Company
All Rights Reserved

9,2,0,4,3,9 | A | 11/18

LE CHEF DU BUREAU D'ETUDES

When considering wire rope requirements the actual working load must include not only the static or dead load but also loads resulting from acceleration, retardation and shock load. Consideration must also be given to the size of the winch wire rope drum, sheaves and method of reeving. Wire rope diameter for lifting or lowering 1/2 in. (13 mm) imperative.

Installing Wire Rope

- 1 - Cut wire rope to length in accordance with the wire rope manufacturers instructions.
- 2 - Feed the end of the wire rope into the smaller anchor hole in the wire rope drum and pull through approximately one foot (0,3 m) of wire rope.
- 3 - Truck the end of the wire rope back into the wire rope anchor pocket forming a loop in the wire rope.
- 4 - Insert the wire rope anchor and pull the wire rope through the slot tightening the wire rope around the wire rope anchor.

CAUTION

Make sure the first wrap of wire rope is flush against the drum flange.

- 5 - Pull the wire rope anchor into position in the drum anchor pocket.

Safe Wire Rope Handling Procedures

- 1 - Always use gloves when handling wire rope.
- 2 - Never use wire rope which is frayed or kinked.
- 3 - Never use wire rope as a sling
- 4 - Always ensure wire rope is correctly spooled and first layer is tight.

Wire Rope Spooling

To allow for uneven spooling and decrease in line pull capacity as the drum fills up, use as short a cable as practical. To rewind wire rope apply tension to eliminate slack. This helps achieve level winding and tight spooling.

Rigging

Make sure all wire rope blocks, tackle and fastenings have sufficient safety margin to handle the required load. Do not allow wire rope to contact sharp edges or make sharp bends which will cause damage to wire rope, use a sheave. Refer to wire rope manufacturers handbook for proper sizing, use and care of wire rope.

Safe Installation Procedures

- 1 - Do not use wire rope as a ground for welding
- 2 - Do not attach a welding electrode to winch or wire rope
- 3 - Never run the wire rope over a sharp edge. Use a correctly sized sheave.
- 4 - When a lead sheave is used, it must be aligned with the center of the drum. The diameter of the lead sheave must be at least 18 times the diameter of the wire rope.
- 5 - Always maintain at least three full wraps of wire rope on the drum.

Air supply

The air supply must be clean and free from moisture.

Air Lines

The inside diameter of the winch air supply lines must not have an inside diameter smaller than 1" IN. (25,4 mm) for flexible lines and 3/4" in. (19 mm) for connectors. Before making final connections, all air supply lines should be purged before connecting to system inlet. Supply lines should be as short and straight as installation conditions will permit. Long transmission lines and excessive use of fittings, elbows, tees, globe valves, etc, cause a reduction in pressure due to restrictions and surface friction in the lines.

Air Line lubricator

Always use an line lubricator with these motors. Use a lubricator having an inlet and outlet at least as large as the inlet on the motor. Install the lubricator in the air line just ahead of the motor.

CAUTION

Lubricator must be located no more than 10 ft. (3m) from the motor.

The air line lubricator should be replenished daily and set to provide 5 to 6 drops per minute of GRADE ISO 68 oil (minimum viscosity 61,2 Cst at 40° C).

Motor

For optimum performance and maximum durability of parts, operate air motor at 90 PSI at 124 cfm (6,3 bar/630 kpa at 3,5 cu.m/min) air pressure. The air motor should be installed as near as possible to the compressor or air receiver.

Initial Operating Checks

Winches are tested for proper operation prior to leaving the factory. Before the winch is placed into service the following initial operating checks should be performed.

- a - When first running the motor some light oil should be injected into the inlet connection to allow good lubrication.
- b - When first operating the winch it is recommended that the motor be driven slowly in both directions for a few minutes.

For winches that have been in storage for a period more than one month the following start-up procedure is required.

- 1 - Pour a small amount of gasoline fluid in the motor inlet port.
- 2 - Operate the motor for 10 seconds to flush out any impurities.
- 3 - Pour small amount of oil in the motor air inlet port.
- 4 - Operate the motor for an additional 2 to 3 seconds.

The winch is now ready to work.

F - OPERATION

The four most important aspects of winch operation are :

- 1 - Follow all safety instructions when operating the winch.
- 2 - Allow only qualified people to operate the winch
- 3 - Subject each winch to a regular inspection and maintenance procedure
- 4 - Be aware of the winch capacity and weight of load at all times.

WARNING

"As regard manriding winches, it is responsibility of the owner or user of the winch to determine whether the winch conforms with local regulations for personnel use"

Winch control

The winch spring loaded manual control throttle is mounted to the air motor.

When viewed from the air motor end move the control throttle handle to the right (clockwise) to pay out wire rope.

When viewed from the air motor end move the control throttle handle to the left (counterclockwise) to haul in wire rope.

To ensure smooth operation of the winch sudden movements of control valve should be avoided.

INGERSOLL-RAND
MATERIAL HANDLING

Copyright 1996
Ingersoll-Rand Company
All Rights Reserved

AIR POWERED MAN-RIDING WINCH

FG05 MR 19

NUMERO DE NOMENCLATURE

NUMERO DU DOCUMENT

9,2,0,4,3,9 | A | 13/18

LE CHEF DU BUREAU D'ETUDES

CAUTION

To avoid damage to the rigging, the structure supporting the rigging and the winch, do not "two-block" the end of the wire rope.

G - LUBRICATION

Wire rope

Refer the wire rope manufacturers recommendations. At a minimum observe the following :

1 - Clean with a brush or steam if there is dirt, rock dust or other foreign material on the surface of the rope

CAUTION

Do not use an acid-based solvent or other cleaning fluid.

2 - Apply a wire rope lubricant or SAE 30W oil.

3 - Brush, drip or spray lubricant weekly, or more frequently, depending on severity of service.

Reduction Gear Assembly

Replace the oil in the reduction housing at least once every year. If the winch is used at a normal frequency, the oil in the reduction housing is suitable for one years operation without changing. However, when the winch is used at a high frequency, the oil may need to be changed on a more frequent basis.

To ensure correct performance, highest efficiency and long life, it is essential that the lubricating oil be maintained at the correct level. The recommended grade of oil must be used at all times since the use of unsuitable oil may result in excessive temperature rise, loss of efficiency and possible damage of the gears.

The reduction gear assembly is filled and shipped with oil from the factory. Use only high quality lubricants in the reduction gear assembly such as high grade EP type oil or their equivalents. Fill the reduction gear assembly until the working rim is covered.

Oil capacity : 3 litres.

Recommended oil :

GRADE SAE 80 W 90 - Kinematic

Viscosity : 145 mm²/s at 40°C

Seals and Bearings

If winch is disassembled, clean all parts thoroughly and coat bearings and seals with clean grease. Use sufficient grease to provide a good protective coat.

Grease features : semi-fluid extreme pressure for ambient temperature from -15°C to +40°C, ASTM at 250°C penetration.

Storage

For exchange winches or winches that will not be operated for extended periods pour a small amount oil into the motor inlet port or supply line. Operate the motor for 2 to 4 seconds to lubricate the motor parts then plug the air inlet port.

H - INSPECTION

There are two types of inspection, the frequent inspection performed by the operator while using the winch and periodic inspections performed by qualified personnel.

Careful inspection on a regular basis will reveal potentially dangerous conditions while still in the early stages, allowing corrective action to be taken before the condition becomes dangerous.

Any deficiency revealed through inspection must be reported to an appointed person. A determination must be made as to whether a deficiency constitutes a safety hazard before resuming operation of the winch.

Records and Reports

Some form of inspection record must be maintained for each winch, listing all points requiring periodic inspection. A written report should be made monthly on the condition of the critical parts of each winch. These reports should be dated, signed by the person who performed the inspection, and kept on file where they are readily available to authorized personnel.

FREQUENT INSPECTION

On a winch in continuous service, frequent inspection should be made at the beginning of each shift. In addition, visual inspections should be conducted during regular service for any damage or evidence of malfunction.

- 1 - OPERATION. Check for visual or abnormal noises which could indicate a defect. Do not operate a winch unless the wire rope feeds onto the winch drum smoothly. If wire rope binds or jumps, clean and lubricate the wire rope. If problem persists, replace the wire rope. Do not operate the winch until all defects have been corrected.
- 2 - AIR SYSTEM. Check air lines, valves and other components for leakage. Repair if necessary.
- 3 - WIRE ROPE. Wire rope is a consumable item which must be replaced when worn. The following list is a guide to the accepted standards by which wire rope must be judged and is not presented as a substitute for an experienced inspector :
 - a . Damage, such as bird cages, kinking, core protrusion, crushing, heat damage, and main strand displacement.
 - b . Corrosion and nicking
 - c . Wear of crown wires. Replace at 1/3 wear of any crown wire.
 - d . Broken wires or strands, particularly at connections. Replacement is necessary if one wire is broken at a connection ; six wires broken within one lay ; three wires broken in one strand within one lay.
 - e . Lubrication.
Replace wire rope if any doubt exists as to wire rope serviceability.
- 4 - WIRE ROPE REEVING. Check reeving and ensure wire rope is properly secured to the drum.
- 5 - CONTROLS. See that controls function properly and return to neutral when released.

PERIODIC INSPECTION

Frequency of periodic inspection depends on the severity of usage : NORMAL, yearly ; HEAVY, semiannually ; SEVERE, quarterly.

Disassembly may be required for HEAVY or SEVERE usage. Keep accumulative records of periodic inspections to provide a basis for continuing evaluation. Inspect all the items in a frequent inspection plus the following :

- 1 - FASTENERS. Check, capscrew, nuts, pins and other fasteners on winch and air system. Replace if missing and tighten or secure if loose.

2 - ALL COMPONENTS. Inspect for wear, damage, distortion, deformation and cleanliness. If external evidence indicates the need, disassemble. Check gears, shafts, bearings, springs and covers. Replace worn or damaged parts. Clean, lubricate and reassemble.

3 - DRUM AND SHEAVES. Check for damage or excessive wear. Replace if necessary.

4 - BRAKE. Perform functional load test on winch. Check ability of the brake to hold rated load.

5 - LABELS AND TAGS. Check for presence and legibility. Replace if necessary.

6 - WIRE ROPE

a - Loose or damaged end connection. Replace if loose or damaged.

b - Changes in the size of the rope cross section. Measure crown-to-crown.

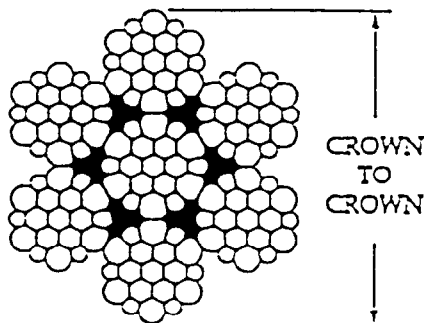

7 - FOUNDATION. Check for the continued ability to sustain the imposed loads.

Winches Not In Regular Use

A winch which has been idle for a period of one month or more, but less than six months, shall be given an inspection conforming with the requirements of "Frequent Inspection" before being placed into service.

A winch which has been idle for a period of over six months shall be given a complete inspection conforming with the requirements of "Periodic Inspection". Standby winches shall be inspected at least semiannually in accordance with the requirements of "Frequent Inspection". If abnormal operating conditions apply, winches may require a more frequent inspection.

I - TROUBLE SHOOTING

This section provides the information necessary for trouble shooting this winch. The trouble shooting guide provides a general outline of problems which could be experienced with normal use of this winch. It lists the trouble, the possible cause, and the possible solution for the trouble experienced.

SYMPTOM	TROUBLE	POSSIBLE REMEDY
Winch will not operate	No air supply to winch	Check connections and hoses in air supply line
	Winch is overloaded	Reduce load to within rated capacity
The winch doesn't run at no load when lifting	The free wheel is mounted upside down	Check the mounting of the free wheel See "MAINTENANCE" Section
Load continues to move when winch is stopped	Brake is slipping	Check brake friction discs, springs and band brake See "MAINTENANCE" section
Winch will not lift load or does not lift rated capacity	Winch is overloaded	Reduce load to within rated capacity
	Motor may be damaged	Inspect motor. Please contact your nearest INGERSOLL-RAND agent.
	Brake is not releasing	Check brake release pilot hole is not restricted Check seals on cylinder piston are not damaged
	Insufficient air supply	Check air supply
Oil leaks from drum bushing area	Air overload protection is disturbed or the using conditions of the winch are not respected	Check overload protection and make its adjustment if necessary See "MAINTENANCE" section
	Reduction assembly is leaking	Disassemble winch and inspect reduction assembly seals
Low power	Low air pressure at the inlet	Check air pressure at the inlet
	Worn or damaged motor	Inspect motor. Please contact your nearest INGERSOLL-RAND agent
	Improper lubrication or dirt building up in the motor	Lubricate as instructed under "LUBRICATION" if this does not help flush the motor as instructed in the "INSTALLATION" Section
Motor does not operate smoothly		Inspect motor. Please contact your nearest INGERSOLL-RAND agent

INGERSOLL-RAND
MATERIAL HANDLING

AIR POWERED MAN-RIDING WINCH

NUMERO DE NOMENCLATURE

Copyright 1996
Ingersoll-Rand Company
All Rights Reserved

FG05 MR 19

NUMERO DU DOCUMENT

92,04,3,9 | A | 17/18 |

LE CHEF DU BUREAU D'ETUDES

J - MAINTENANCE

WARNING

- . Never perform maintenance on the winch while it is supporting a load.
- . Before performing maintenance, tag controls : DANGER - DO NOT OPERATE - EQUIPMENT BEING REPAIRED.
- . Only allow qualified service personnel to perform maintenance.
- . After performing any maintenance on the winch, test winch to 125% of its rated capacity before returning to service.
- . Do not use Trichloroethylene to clean parts.

General Disassembly Procedures

The following instructions provide the necessary information to disassemble, inspect, repair, and assemble the winch. Refer the winch assembly drawing provided in the Parts Section.
If a winch is being completely disassembled for any reason, follow the order of the topics as they are presented.

It is recommended that all maintenance work on the winch be performed on a bench.
In the process of disassembling the winch, observe the following :

- 1 - Never disassemble the winch any further than is necessary to accomplish the needed repair. A good part can be damaged during the course of disassembly.
- 2 - Never use excessive force when removing parts. Tapping gently around the perimeter of a cover or housing with a soft hammer, for example, is sufficient to break the seal.
- 3 - Do not heat a part with a torch to free it for removal, unless the part being heated is already worn or damaged beyond repair.
In general, the winch is designed to permit easy disassembly and assembly. The use of heat or excessive force should not be required.
- 4 - Keep the work area as clean as practical, to prevent dirt and other foreign matter from getting into bearings or other moving parts.
- 5 - All seals and O'rings should be discarded once they have been removed. New seals and O'rings should be used when assembling the winch.
- 6 - When grasping a part in a vise always use leathercovered or copper-covered vise jaws to protect the surface of the part and help prevent distortion. This is particularly true of threaded members and housings.
- 7 - Do not remove any part which is press fit in or on a subassembly unless the removal of that part is necessary for repairs or replacement.

INGERSOLL-RAND
MATERIAL HANDLING

Copyright 1996
Ingersoll-Rand Company
All Rights Reserved

AIR POWERED MAN-RIDING WINCH

FG05 MR 19

NUMERO DE NOMENCLATURE

NUMERO DU DOCUMENT

9,2,0,4,39 | A | 18/18

LE CHEF DU BUREAU D'ETUDES

K - PARTS

INGERSOLL-RAND
MATERIAL HANDLING

EXTERNAL BAND BRAKE
ASSEMBLY DRAWING

NUMERO DE NOMENCLATURE

L615

NUMERO DU DOCUMENT

92-04-08 A 1 / 6

Ph. Demeese

LE CHEF DU BUREAU D'ETUDES

Copyright © 1996
Ingersoll-Rand Company
All Rights Reserved

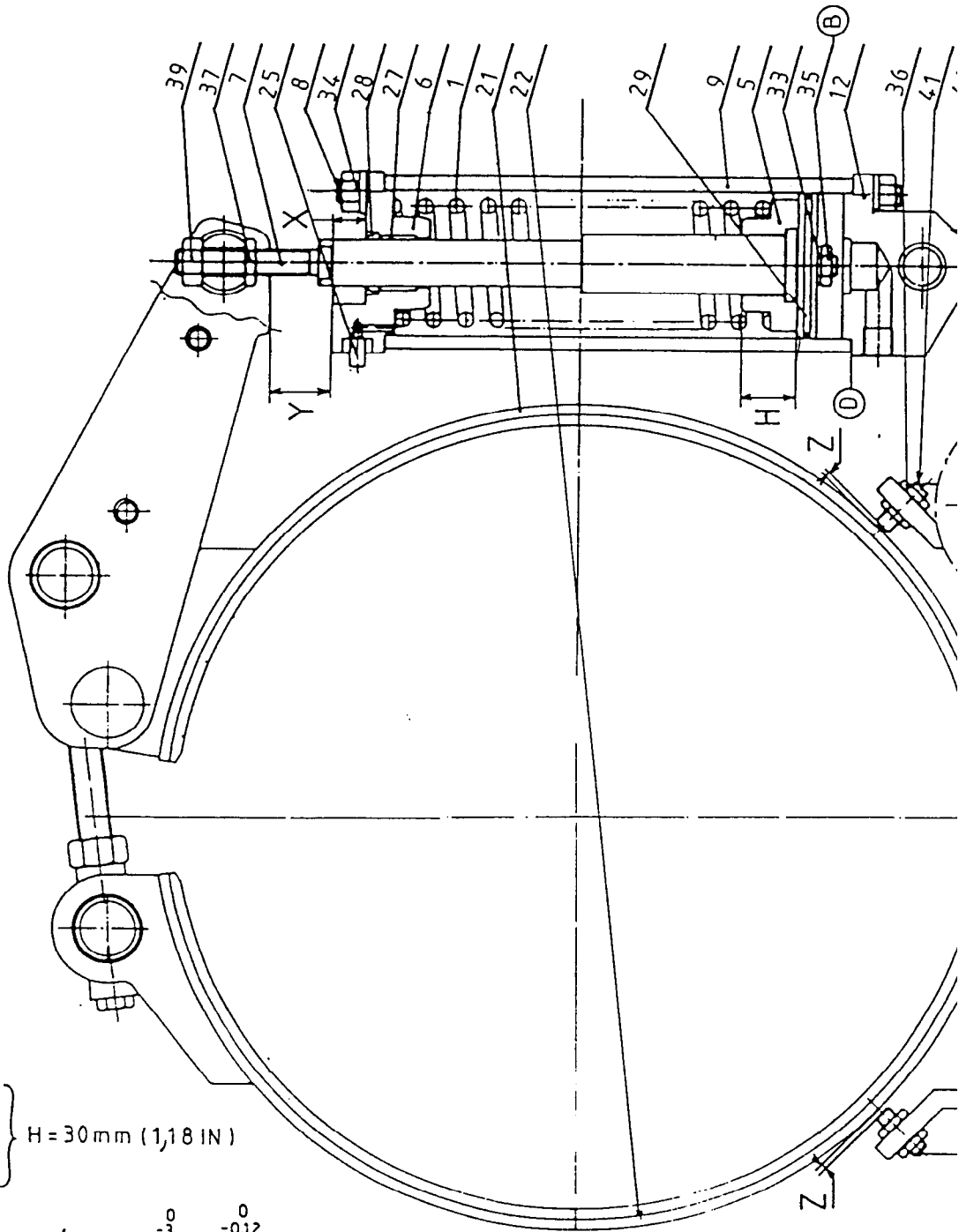

NIVEAU D'HUILE }
Oil level } H = 30 mm (1,18 IN)
Ölstand }

CÔTES DE REGLAGE | Y = 33⁰₋₃ mm (1,3⁰_{-0,12} IN)
Adjusting dimensions | X = 18 mm (0,71 IN)
Passungsmaß | Z = 1,5 mm (0,059 IN)

- Ⓐ LOCTITE INSTAJOINT 574
- Ⓑ LOCTITE FREIN FILET 243
- Ⓒ LOCTITE TUBETANCHE 577
- Ⓓ SILICOMET

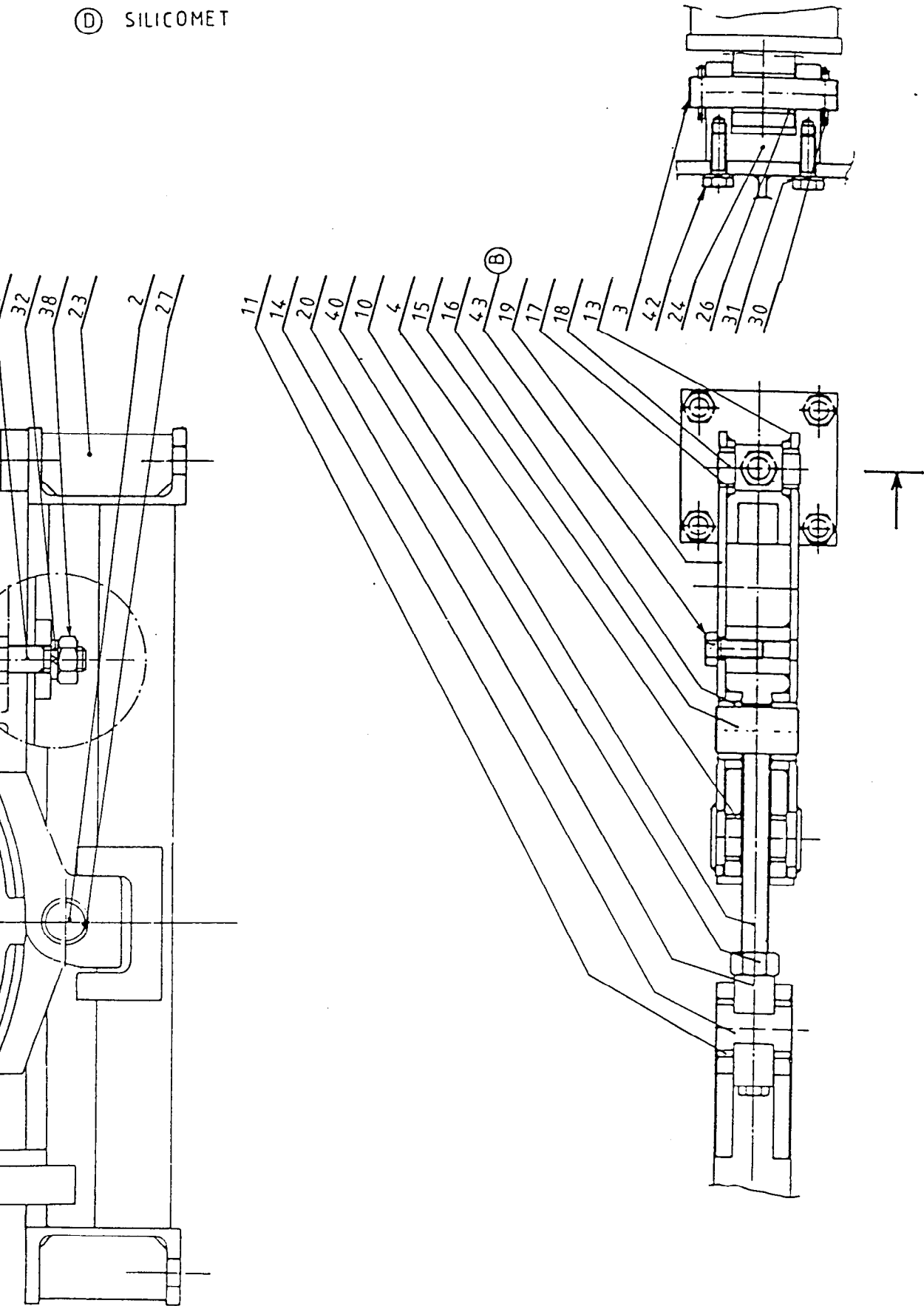

INGERSOLL-RAND
MATERIAL HANDLING

Copyright 1996
Ingersoll-Rand Company
All Rights Reserved

EXTERNAL BAND BRAKE

NUMERO DE NOMENCLATURE

L615

NUMERO DU DOCUMENT

19210408 A 26

LE CHEF DU BUREAU D'ETUDES

REPERE ITEM HINWEIS	DESIGNATION	DESCRIPTION	BEZEICHNUNG	Quantité Quantity Anzahl	CODE	CPN
1	Ressort	Spring	Feder	1	9430-0046	38530044
2	Axe de bande de frein	Brake band axle	Bremsbandachse	1	9539-7022	38531273
3	Axe de chape	Cover axle	Abdeckungsachse	1	9539-8024	38531265
4	Bague	Ring	Ring	2	9539-0048	38530051
5	Rondelle d'appui	Sill washer	Washer	1	9539-0053	38530069
6	Nez de vérin	Cylinder nose	Zylindersnase	1	9539-0054	38530077
7	Tige de vérin	Cylinder rod	Zylinderspindel	1	9539-7055	38531430
8	Tirant	Tension piece	Spannstange	4	9539-8057	38531281
9	Chemise de vérin	Cylinder casing	Zylinderbüchse	1	9539-0058	38530085
10	Vis de réglage	Setting screw	Stellschraube	1	9539-7061	38531299
11	Bague	Ring	Ring	2	9539-0071	38530093
12	Fond de vérin	Cylinder bottom	Zylinderboden	1	9539-0087	38530101
13	Demi levier	Half lever	Halbhebel	1	9615-8028	38531307
14	Noix lisse	Smooth wheel	Glatte Nuß	1	9615-7029	38531315
15	Noix filetée	Screwed sprocket wheel	Schrausennuß	1	9615-7030	38531323
16	Bague	Ring	Ring	2	9615-0031	38530119
17	Bague	Ring	Ring	2	9615-0032	38530127
18	Noix lisse	Smooth wheel	Glatte nuß	1	9615-7033	38531331
19	Demi levier	Half lever	Halbhebel	1	9615-8034	38531349
20	Entretoise	Distance ring	Distanzring	1	9615-0035	38530135
21	Demi bande de frein	Half brake band	Halbbremsband	1	9615-8036	38531356
22	Demi bande de frein	Half brake band	Halbbremsband	1	9615-8037	38531364
23	Chassis	Frame	Rahmen	1	9615-8038	38531372
24	Chape	Cover	Abdeckung	1	9615-0057	38530150
25	Silencieux	Muffler	Schalldämpfer	1	6848-9232	38529996
26	Bague auto-lubrifiante	Self-lubricating ring	Selbstschmierender Ring	2	5910-5226	38530325
27	Bague auto-lubrifiante	Self-lubricating ring	Selbstschmierender Ring	2	5910-5426	38530333
28	Bague d'étanchéité	Sealing ring	Dichtring	1	5810-5830	38530309

Pour toute commande de pièces de rechange, il est recommandé de rappeler le numéro porté sur la plaque d'identification de l'appareil

For each demand of spare parts, it is recommended to specify the number written on the identification plate of the device

Bei Bestellung von Ersatzteilen bitte Seriennummer auf dem Identifizierungsschild des Geräte angeben

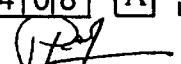
INGERSOLL-RAND MATERIAL HANDLING	EXTERNAL BAND BRAKE	NUMERO DE NOMENCLATURE L615
		NUMERO DU DOCUMENT 9,2,0,4,0,8, A, 3,6,
Copyright 1996 Ingersoll-Rand Company All Rights Reserved		 LE CHIEF DU BUREAU D'ETUDES

REPERE ITEM HINWEIS	DESIGNATION	DESCRIPTION	BEZEICHNUNG	Quantité Quantity Anzahl	CODE	CPN
29	Piston	Piston	Kolben	1	5811-0730	38530317
30	Goupille fendue	Split pin	Stift	2	4630-1119	38530457
31	Rondelle grower	Split washer	Scheibe	2	4520-0010	38522223
32	Rondelle Grower	Split washer	Scheibe	4	4520-0016	38526901
33	Rondelle MU	Washer	Scheibe	1	4500-0112	38525523
34	Ecrou frein	Lock nut	Bremsschraube	8	4370-1411	38530440
35	Ecrou Hm	Thin Nut	Mutter	1	4320-0112	38525515
36	Ecrou Hm	Thin nut	Mutter	4	4320-2112	38530416
37	Ecrou Hm	Thin nut	Mutter	1	4320-2312	38530424
38	Ecrou H	Nut	Mutter	4	4300-1011	38526893
39	Ecrou H	Nut	Mutter	1	4300-5811	38530408
40	Ecrou H	Thin nut	Mutter	1	4300-5911	38531448
41	Vis Hc	Screw	Schraube	2	4200-4207	38530390
42	Vis H	Screw	Schraube	2	4100-0401	38528667
43	Vis H	Screw	Schraube	2	4100-3401	38530028
44	Vis H	Screw	Schraube	4	4100-3901	38530341

Pour toute commande de pièces de rechange, il est recommandé de rappeler le numéro porté sur la plaque d'identification de l'appareil

For each demand of spare parts, it is recommended to specify the number written on the identification plate of the device

Bei Bestellung von Ersatzteilen bitte Seriennummer auf dem Identifizierungsschild des Gerätes angeben

DISASSEMBLY INSTRUCTIONS
(Direct Brake on Drum)

- Unwind drum cable
- Position at the top the holes ϕ 40 mm for handling forecast on the drum

1 - Disassembly of brake cylinder

1.1 - Stripping down of the whole of brake cylinder

- 1.1.1 - Release nut ITEM 40 (wrench : 27 mm on flat sides)
- 1.1.2 - Slightly pilot the drum on the lowering direction and unscrew the adjustment screw
- 1.1.3 - Remove nut ITEM 39 (wrench 22 mm on flat sides)
- 1.1.4 - Remove clamp collar
- 1.1.5 - Disconnect hose ITEM 7

- 1.1.6 - Remove one split pin ITEM 30
- 1.1.7 - Remove cover axle ITEM 3
- 1.1.8 - Strip down the whole of brake cylinder

1.2 - Disassembly of the whole of brake cylinder

- 1.2.1 - Removal of spring ITEM 1
 - Remove 2 to the 4 tension pieces ITEM 8 (wrench : 19 mm on flat sides)
 - Assembly 2 screw rods M12 Lg 400 mm with nuts M12
 - Remove the 2 last tension pieces ITEM 8 (wrench : 19 mm on flat sides)
 - Decompress spring ITEM 1
 - Remove the 2 screw rods
 - Remove cylinder nose ITEM 6
 - Remove spring ITEM 1
- 1.2.2 - Drain oil from cylinder casing (ITEM 9)
- 1.2.3 - Strip down the whole of the cylinder rod ITEM 7, Piston ITEM 29 and sill washer ITEM 5
 - NB : Nut ITEM 35 will be fixed and tightened with Blue LOCTITE (ref. 243) and with 2 mk torque
- 1.2.4 - Expel cylinder casing ITEM 9 from cylinder bottom ITEM 12

2 - Disassembly of band brake

2.1 - Stripping down of the winch from skid frame

- 2.1.1 - Strip down the whole of brake cylinder (see 1.1)
- 2.1.2 - Disconnect limit switch hoses if the winch is fettetted with any (see : strip down air compressed limit switch)
- 2.1.3 - Disconnect hoses Rep : 44-32-38
- 2.1.4 - Remove fixing screws on winch (clé de 24 s/plats)
- 2.1.5 - Strip down the winch from skid frame (Rep 23)

2.2 - Stripping down of the whole of the both half brake bands

- 2.2.1 - Open the brake band unscrewing the setting screw ITEM 10
- 2.2.2 - Strip down the whole of the both half brake bands ITEM 21 and ITEM 22 from the winch

2.3 - Disassembly of the whole of the both half brake bands

2.3.1 - Remove brake band axle ITEM 2

2.3.2 - Removal of smooth wheel ITEM 14

- Remove nut ITEM 40 from setting screw (ITEM 10) (wrench : 27 mm on flat sides)
- Remove Distance ring ITEM 20
- Remove Setting screw ITEM 10
- Remove Smooth wheel ITEM 14

2.3.3 - Disassembly of the both half levers ITEM 13 and ITEM 19

- Remove screws ITEM 43 (wrench : 19 mm on flat sides)
- Remove sprocket wheel ITEM 15
- Remove Smooth wheel ITEM 18
- Remove the both half levers ITEM 13 and ITEM 19

Inspection and repair

Use the following procedures to inspect, and repair the components of the winch.

CAUTION

A bearing that appears loose or rotates roughly must be replaced. Failure to observe this precaution will result in bearing and/or winch component damage.

All disassembly parts should be inspected to determine the fitness for continued use.
Pay particular attention to the following :

1 - Inspect all the self-lubricating rings - All internal diameter ovalisations require their replacement

IMPORTANT NOTE : Every self-lubricating rings are stopped in translation by several centre mark.

2 - Inspect all the axles :

- Smooth wheel (ITEM 14)
- Smooth wheel (ITEM 18)
- Sprocket wheel (ITEM 15)
- Brake band axle (ITEM 2)
- Cover axle (ITEM 3)
- Cylinder rod (ITEM 7)

All external diameter damage require their replacement

3 - Inspect welded axles on the half levers - All external diameter damage require their replacement

4 - Inspect the half brake bands

- Nominal thickness of linings = 5 mm
- Minimum thickness = 2 mm

If this dimension is lower, change the half brake band (ITEM 21, ITEM 22)

5 - Inspect brake cylinder joints and the internal diameter surface condition of wrapper cylinder - replace them if necessary.

6 - Check the spring condition ITEM 1 - If after a large period of use an important diminution of its efficiency is established, make its replacement.
(F theoretical = 100 daN under deflection $f = 76$ mm)

ASSEMBLY INSTRUCTIONS
(Direct Brake on Drum)

- Assembly of brake cylinder

1.1 - The reassembling of the brake cylinder has to be carried out in the opposite direction to the one used for dismantling
(see : 1.2 - Disassembly of the whole of brake cylinder)

NB : - Sealing between cylinder casing ITEM 9 and cylinder bottom ITEM 12 will made by joint of "SILICOMET" (chamfer 2x45°)
- See NB on 1.2.2 for nut ITEM 35
- Before closing the brake cylinder, full in the spring housing with oil SP 150 type (see winch assembly drawing) Level H=30 mm and stock brake cylinder in vertical position for the following operations
- Grease the inside of the sealing ring ITEM 28
- Nuts ITEM 34 will be tightened with 4,5 m kg torque

1.2 - The reassembling of the whole of brake cylinder has to be carried out in the opposite direction to the one used for dismantling (see : 1.1 - Stripping down of the whole of brake cylinder)

NB : - Sealing of all nipples will made by "LOCTITE TUBETANCHE 577"

2 - Assembly of band brake

Reassembly will have to be carried out in the opposite direction to the one used for dismantling (see 2 - Disassembly of hand brake)

NB : - Grease all axles
- Screws ITEM 43 will be fixed and tightened with BLUE LOCTITE (ref. 243) and with 6,8 m kg torque, only after light tensioning of brake cylinder
- Stop screws rep 41 before the mounting of the winch on this skid frame
- Screws ITEM 44 will be tightened with 16 m kg torque

3 - Adjusting of band brake

The adjusting dimensions are pointed out on the winch assembly drawing

- Y=33° 3 (mm) : his adjusting is done by using the adjusting screw ITEM 10 and of the clamping of the nut ITEM 40 at the couple of 10 m kg
- X=18 mm : his adjusting is done by the slightly guidance of the brake jackscrew in the lowering direction and by blocking the nuts ITEM 37 and 39
- Z=1,5 (mm) : Clearance of both half brake band(wrench : 17 mm on flat sides and hexagonal-hollow head wrench 5 mm)

INGERSOLL-RAND
MATERIAL HANDLING

Copyright © 1996
Ingersoll-Rand Company
All Rights Reserved

FG05MR19
MAN-RIDING WINCH
ASSEMBLY DRAWING

NUMERO DE NOMENCLATURE	
L615	
NUMERO DU DOCUMENT	
96-06-01	1 / 3
<i>Ph. Demeese</i>	
LE CHEF DU BUREAU D'ETUDES	

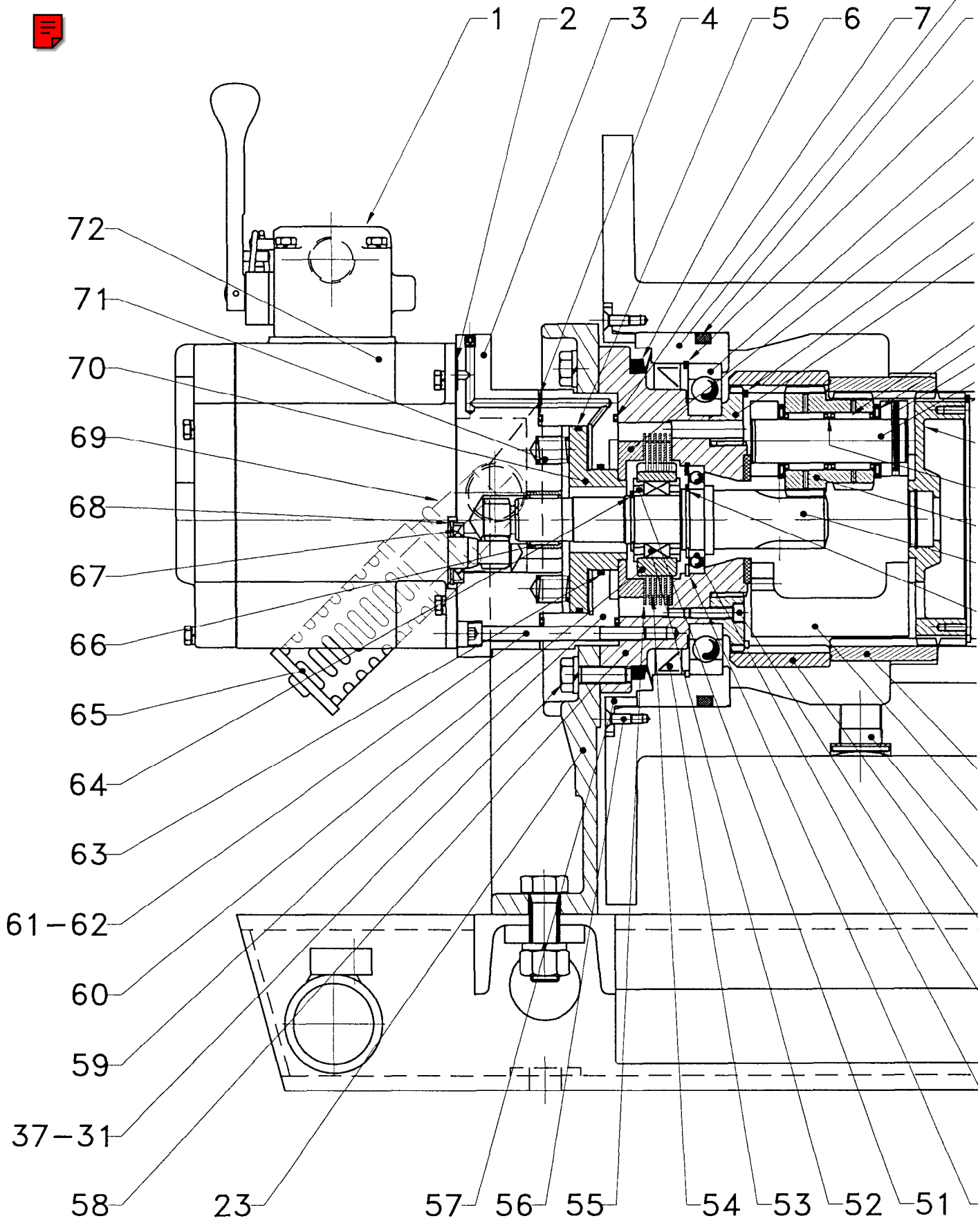

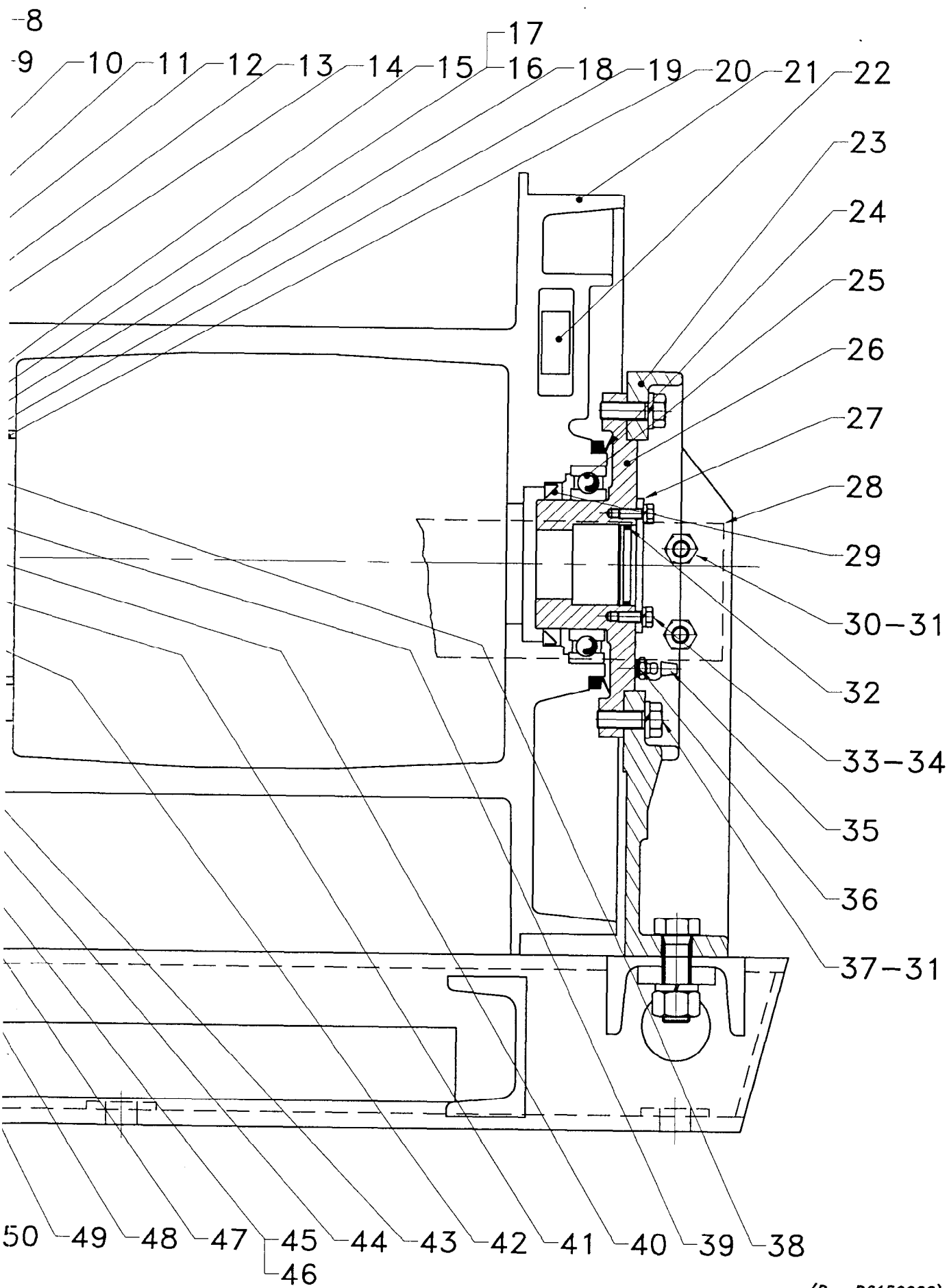

INGERSOLL-RAND**MATERIEL HANDLING**Copyright © 1996
Ingersoll-Rand Company
All Rights Reserved**FG05MR19
WINCH ASSEMBLY
PARTS LIST**

NUMERO DE NOMENCLATURE

L615

NUMERO DU DOCUMENT

96/06/01 2/3*Ph. Demeese*

Le chef du bureau d'études

Rep Item	Désignation	Description	Qté. Qty.	CODE	
				STANDARD	
1	Air control valve		1	36310042	
• 2	O-ring		1	58226629	
3	Flange		1	96150259	
• 4	O-ring		1	58212529	
• 5	O-ring		1	58210929	
• 6	Joint		1	58405831	
• 7	O-ring		2	58216929	
8	Rolling bearing		1	96150044	
• 9	Ring		1	58217929	
10	Expensive ring		1	47853932	
11	Ball bearing		1	50800024	
12	Distance ring		1	96150045	
13	Expensive ring		1	47836832	
14	Ring gear support		1	96150043	
15	Needle bearing		8	56503324	
16	Needle stop		8	56054225	
17	Thrust washer		8	57312632	
18	Pin		4	46504220	
19	Satellite axle		4	95738019	
20	Expensive ring		1	47847832	
21	Drum		1	96158052	
22	Wedge		1	96150009	
23	Flange		2	96157002	
• 24	Joint		1	58404831	
25	Ball bearing		1	50050015	
26	Rear bearing		1	96158049	
27	Blind washer		1	96190013	
28	Distance ring		2	96150050	
• 29	Sealing ring		1	58000830	
30	Screw		8	41006701	
31	Washer		32	45200010	
• 32	O-ring		1	58224229	
33	Screw		3	41000201	
34	Washer		3	45200006	
35	Plug		1	61017128	
36	Greaser		1	67301727	
37	Screw		24	41000401	
38	Claw of positive clutch		1	35730001	
39	Distance ring		4	95730021	
40	Satellite		4	95730018	
41	Driving pinion		1	96158260	

INGERSOLL-RAND**MATERIEL HANDLING**Copyright © 1996
Ingersoll-Rand Company
All Rights Reserved**FG05MR19
WINCH ASSEMBLY
PARTS LIST**

NUMERO DE NOMENCLATURE

L615

NUMERO DU DOCUMENT

96/06/01 3/3*Ph. Demeese*

Le chef du bureau d'études

Rep Item	Désignation	Description	Qté. Qty.	CODE	
				STANDARD	
42	Circlips		1	47700035	
43	57 teeth-ring gear		1	95730056	
44	Satlite support		1	96150023	
• 45	Plug		2	65160932	
• 46	Joint		2	58408031	
47	60 teeth-ring gear		1	95730055	
48	Screw		4	41301006	
49	Ball bearing		1	50800007	
50	Circlips		1	47703062	
51	Eccentric ring		2	96190017	
52	Free wheel		1	55965932	
• 53	Sealing ring		1	58019230	
54	Steel disc		5	63060032	
55	Friction disc		6	63059932	
56	Screw		6	41101603	
57	Stop		1	96150051	
58	Front bearing		1	96158042	
59	Brake housing		1	96150011	
60	External ring of free wheel		1	96190018	
61	Screw M8-93		6	41319606	
62	Screw M8-60		6	41302206	
63	O'ring		1	58222929	
64	Circlips		1	47700028	
65	Muffler		2	68490632	
66	Needle bearing		1	56473320	
• 67	Sealing ring		1	58020030	
68	Circlips		1	47703035	
69	Elbow		2	68246232	
70	Piston		1	96150013	
71	Spring		6	69167132	
72	Motor		1	36200043	

•	Recommended Spare
---	-------------------

DISASSEMBLY INSTRUCTIONS
(Winch)

- Unwind drum cable
- Strip down the set of limit switch if the winch is fitted with any (see : strip down air compressed limit switch)
- Point drum plug downwards in order to empty the reducer
- Strip down the whole of the winch and skid frame from its support
- Strip down band brake (cf. Disassembly Instructions for Direct brake on drum)
- Drain oil from reducer ; use hexagonal-hollow head wrench 14 mm
- Tip the winch on the rear flange

1 - Stripping down of multiple brake disc

- 1.1 - Disconnect the control valve and motor hoses
- 1.2 - Remove the whole of air control valve
- 1.3 - Remove the whole of air motor rep. 72 (see "remove the whole of air motor" on disassembly instructions air motor)
- 1.4 - Remove O'ring rep ITEM 2
- 1.5 - Remove the muffler ITEM 65
- 1.6 - Remove the screws ITEM 61 and 62
- 1.7 - Strip down the flange ITEM 3
- 1.8 - Remove the O' ring ITEM 4
- 1.9 - Remove springs ITEM 71 and remove the needle bearing ITEM 66
- 1.10 - Remove O'ring ITEM 7
- 1.11 - Strip down the whole of the brake housing ITEM 59, piston ITEM 70 and distance ring ITEM 12
 - 1.11.1 - Expel distance ring ITEM 12 from ITEM 70 (Warning : restrained shrink on + "Blocpresse")
 - 1.11.2 - Expel piston ITEM 70 from ITEM 59
 - 1.11.3 - Remove O'rings ITEM 5 and 63
- 1.12 - Remove O'rings ITEM 7
- 1.13 - Remove circlips ITEM 64
- 1.14 - Strip down the whole of free wheel ITEM 51, ITEM 52 and ITEM 60
- 1.15 - Strip down the whole of brake set ITEM 54 and 55

2 - Multiple brake disc assembly

Reassembly will have to be carried out in the opposite direction to the one used for dismantling

Importants remarks :

- Direction of assembling of the free wheel : external ring ITEM 51 blocked in rotation with free rotation of gear ITEM 41 in counterclockwise (side view of pneumatic motor)
- Use LOCTITE BLOC PRESSE 601 for introduction of ITEM 12 in ITEM 70

3 - Disassembly gearing block

- 3.1 - Remove air control valve rep. 1 and air motor rep 72
- 3.2 - Remove the whole multiple brake disc (see front of paragraph)
- 3.3 - Remove screws ITEM30 and washers ITEM 31 from Distancepiece ITEM 28
(wrench : 17 mm on flat sides)
- 3.4 - Remove screws ITEM 37 and washers ITEM 31 from Front Flange ITEM 23
(wrench : 17 mm on flat sides)
- 3.5 - Remove front flange ITEM23
- 3.6 -Strip down screws rep 56 and remove stop rep 57

- 3.7 - Strip down the whole of the front bearing ITEM 58, Rolling bearing ITEM 8 and Ring gear support ITEM 14 (Extraction equipment - Code M 615-1300)
- 3.7.1 - Remove screws ITEM 48 from Ring gear support (ITEM 14)
(Hexagonal-hollow head wrench 5 mm)
 - 3.7.2 - Remove ring gear support ITEM 14
 - 3.7.3 - Remove front bearing ITEM 58 and joint ITEM 6
 - 3.7.4 - Remove circlips ITEM 50
 - 3.7.5 - Remove circlips ITEM 42
 - 3.7.6 - Strip down the whole of driving pinion ITEM 41 and ball-bearing ITEM 49
 - 3.7.7 - Expel Sealing ring ITEM 53 from Rolling bearing (ITEM 8)
 - 3.7.8 - Remove circlips ITEM 10
 - 3.7.9 - Expel Ball bearing ITEM 11 from Rolling bearing (ITEM 8)
- 3.8 - Remove Expansive ring ITEM 14 and Ring gear ITEM 47
- 3.9 - Strip down the whole of the satellite support ITEM 44 and satellite ITEM 40
- 3.9.1 - Push out pins ITEM 18 from satellite support (ITEM 44) (pin punch $\phi 4$)
 - 3.9.2 - Push out satellites axles ITEM 19
 - 3.9.3 - Remove satellites ITEM 40
 - 3.9.4 - Remove needles bearings ITEM 15 and Distance rings ITEM 39
 - 3.9.5 - Remove needles stop ITEM 16 and thrust-washers ITEM 17
- 3.10 - Remove ring gear ITEM 43
- 3.11 - Remove claw of positive clutch ITEM 38
- 3.12 - Remove expansive ring ITEM 20

4 - Dismantling of rear side of winch

Dismantling of rear side of winch is separate from the rest of the dismantling of the winch

- 4.1 - Remove screws ITEM 30 and Washers ITEM 31 from Distance ring (ITEM 28)
(Wrench : 17 mm on flat sides)
- 4.2 - Remove screws ITEM 37 and Washers ITEM 31 from Rear flange (ITEM 23)
(Wrench : 17 mm on flat sides)
- 4.3 - Remove rear flange ITEM 23
- 4.4 - Strip down the whole of the rear bearing ITEM 26 and blind washer ITEM 27
- 4.5 - Remove Joint ITEM 24
- 4.6 - Remove Ball bearing ITEM 25
- 4.7 - Remove Sealing ring ITEM 29

N.B. - Reassembly will have to be carried out in the opposite direction to the used for dismantling

- Screws ITEM 37 from rear Flange ITEM 23 will be tightened with 4,83 m kg torque
- Screws ITEM 30 from Distance ring ITEM 28 will be tightened to torque 4,83 m kg only after winch has been put on skid frame.

Cleaning, Inspection and Repair

Use the following procedures to clean, inspect, and repair the components of the winch.

Cleaning

CAUTION

A bearing that appears loose or rotates roughly must be replaced. Failure to observe this precaution will result in bearing and/or winch component damage.

Clean all winch component parts in solvent. The use of a stiff bristle brush will facilitate the removal of accumulated dirt and sediments in the drum and reduction assembly. Dry each part using low pressure, filtered compressed air.

**INGERSOLL-RAND
MATERIAL HANDLING**

Copyright 1996
Ingersoll-Rand Company
All Rights Reserved

AIR POWERED MAN-RIDING WINCH

FG05MR19

NUMERO DE NOMENCLATURE

L 615

NUMERO DU DOCUMENT

[9|6|0|6|0|5] [] [3|4|]

LE CHEF DU BUREAU D'ETUDES

Inspection

All disassembly parts should be inspected to determine the fitness for continued use. Pay particular attention to the following :

- 1 - Inspect all gears for worn, cracked, or broken teeth.
- 2 - Inspect all bushings for wear, scoring, or galling.
- 3 - Inspect all bearings for play, distorted races, pitting and roller or ball wear or damage. Inspect bearings or freedom of rotation.
- 4 - Inspect shafts for ridges caused by wear. If ridges caused by wear are apparent on shafts, replace the shaft. Inspect all surfaces on which oil seal lips seat. These surfaces must be very smooth to prevent damage to the seal lip.
- 5 - Inspect all threaded items and replace those having damaged threads.
- 6 - The multidisc brake does not require any adjustment. The maintenance being limited to the check of brake discs.
 - nominal size of piling up $16 \pm 0,5$
 - wearing size of brake discs : 14 mm at minimum

Important nota :

- . No friction disc must have a smooth friction surface
- . Grooves have a nominal depth of 0,2 mm on each face of the discs

Repair

Actual repairs are limited to the removal of small burrs and other minor surface imperfections from gears and shafts. Use a fine stone or emery cloth for this work.

Do not use steel wool.

- 1 - Worm or damaged parts must be replaced. Refer to the applicable Parts Listing for specific replacement parts information.
- 2 - Inspect all remaining parts for evidence of damage. Replace or repair any part which is in questionable condition. The cost of the part is often minor in comparison with the cost of redoing the job.
- 3 - Smooth out all nicks, burrs, or galled spots on shafts, bores, pins, or bushings.
- 4 - Examine all gear teeth carefully, and remove nicks or burrs.
- 5 - Polish the edges of all shaft shoulders to remove small nicks which may have been caused during handling.
- 6 - Remove all nicks and burrs caused by lockwashers.
- 7 - Replace all gaskets, oil seals, and O'rings any time the winch is disassembled for repair.

**ASSEMBLY INSTRUCTIONS
(Winch)****1 - Reducer assembly****1.1 - Orientation of satellites**

- 1.1.1 - Assemble the 4 satellites on to the support
- 1.1.2 - Adjust the 4 satellites as shown on drawing below

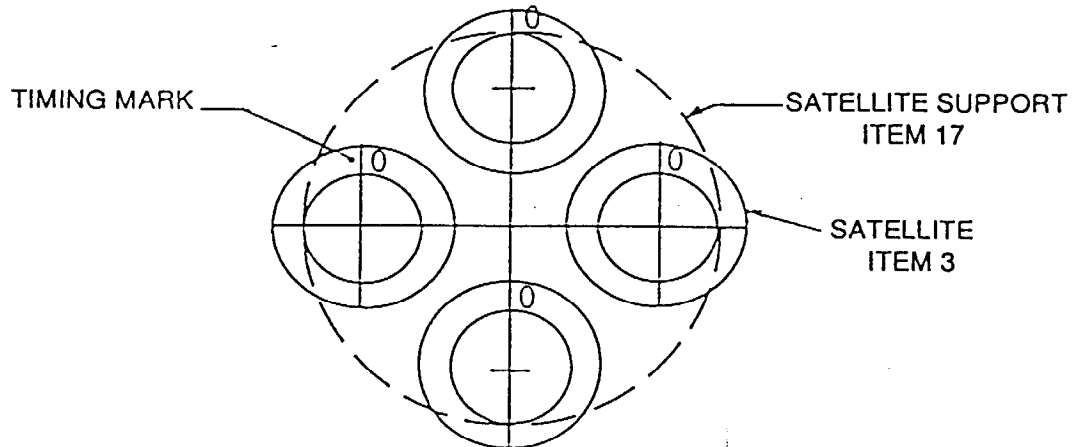

1.1.3 - Clutch in Ring gear ITEM 47

1.1.4 - Assemble driving pignon ITEM 41 to adjust the 4 satellites then remove ring gear ITEM 47

1.2 - The reassembling of the reducer has to be carried out in the opposite direction to the one used for dismantling

N.B - Screws ITEMS 56,48, 61 and 62 will be fixed and tightened with blue LOCTITE (ref. 243)

- Screws ITEM 37, from front Flange ITEM 23, will have to be tightened with 4,83 mkg torque

- Screws ITEM 30, from Distance ring ITEM 28, will have to be tightened to torque 4,83 mkg only after winch has been put on skid frame

2 - Brake system assembly

(see 2 - Stripping down of brake system).

3 - Motor assembly

(see 1 - Stripping down of motor)

4 - Winch assembly

4.1 - Reassemble Reduction Gear

4.2 - Reassemble multiple brake disc

4.3 - Reassemble compressed air motor

4.4 - Reassemble Air control valve

4.5 - Reassemble band brake

4.6 - Reassemble winch on skid frame

4.7 - Connect all air hoses as described in pneumatic scheme

INGERSOLL-RAND
MATERIAL HANDLING

Copyright © 1996
Ingersoll-Rand Company
All Rights Reserved

AIR CONTROL VALVE
ASSEMBLY DRAWING
AND PARTS LIST

NUMERO DE NOMENCLATURE

L615

NUMERO DU DOCUMENT

96-06-03 1 / 1

Ph. Demeese

LE CHEF DU BUREAU D'ETUDES

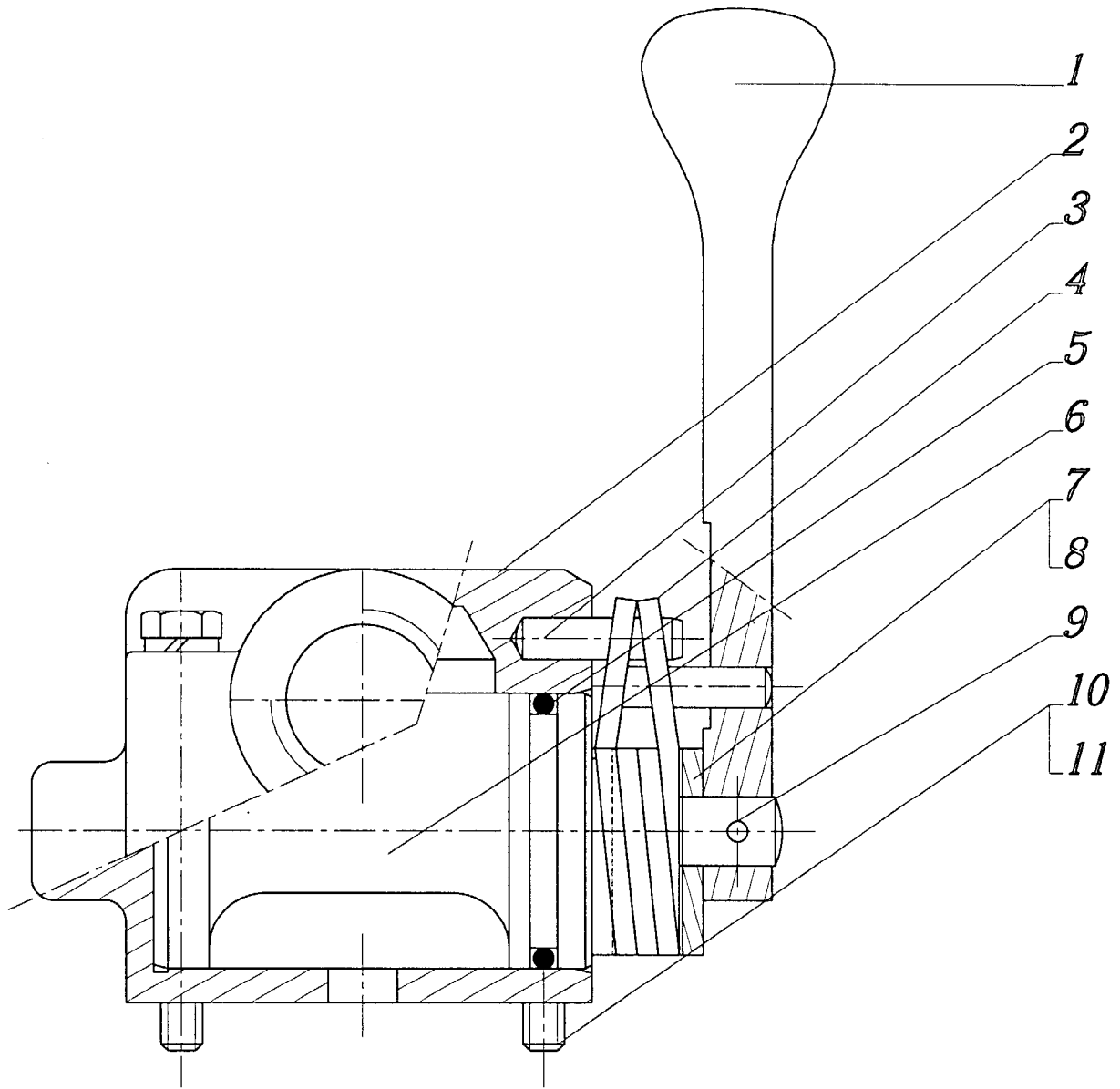

ITEM N°	DESCRIPTION OF PART	TOTAL QTY	PART N°
1	Control lever	1	96180031
2	Valve housing	1	96310122
3	Pin	2	46001206
4	Return spring	1	96180035
● 5	O'ring	1	58210229
● 6	Rotary valve	1	96310048
7	Screw	2	41103403
8	Pin	1	46507220
9	Stop	1	96180034
10	Screw HM	4	41016601
11	Lock washer	4	45200006

● Recommended Spare

DISASSEMBLY INSTRUCTIONS
(air control valve)

1. Remove screws (10) and lock washers (11).
2. Remove the valve assembly from the motor.
3. Tap out the pin (8).
4. Extract the control lever (1).
5. Remove screws (7).
6. Remove stop (9).
7. Remove the return spring (4).
8. Pull out the rotary valve (6).

NOTICE

- Localize the mounting position of the rotary valve in the valve housing.

9. Remove 'O' ring (5).

Inspection

Worn or damaged parts must be replaced, polish the edges of rotary valve to remove small nicks if necessary.

ASSEMBLY INSTRUCTIONS
(air control valve)

Assembly of control valve is the same as disassembly in opposite order.

NOTICE

- Mounting of rotary valve must be done carefully to avoid damage. Lubricate rotary valve before assembly.

Lubricate spring (4).

Screws (7) must be installed with Loctite ® No. 243.

INGERSOLL-RAND
MATERIAL HANDLING

Copyright © 1996
Ingersoll-Rand Company
All Rights Reserved

AIR GEAR MOTOR ASSEMBLY DRAWING

NUMERO DE NOMENCLATURE

L615

NUMERO DU DOCUMENT

96-06-02 1 / 2

Ph. Demeese

LE CHEF DU BUREAU D'ETUDES

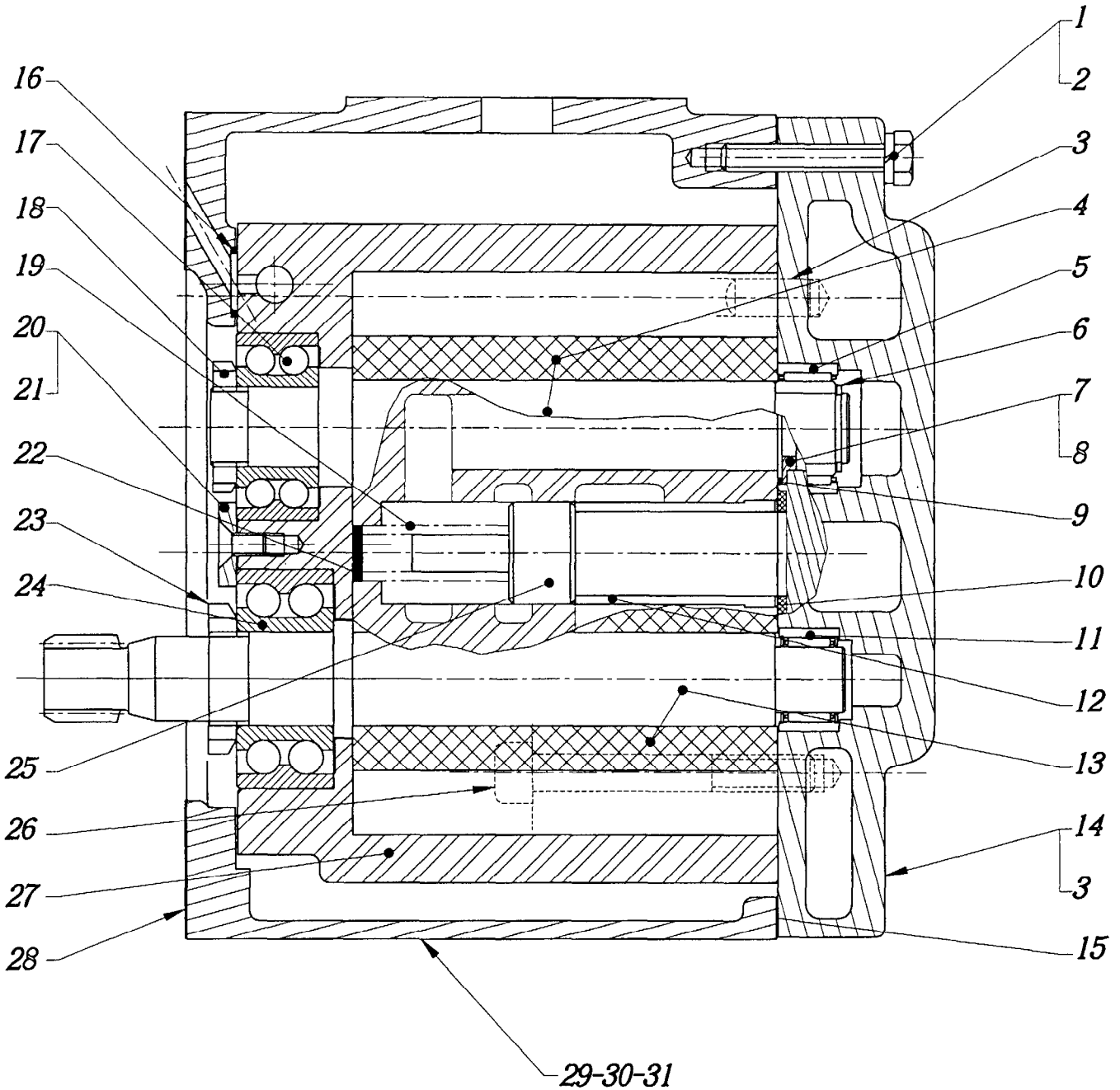

(Dwg D6150023)

INGERSOLL-RAND
MATERIEL HANDLING
 Copyright © 1996
 Ingersoll-Rand Company
 All Rights Reserved

AIR GEAR MOTOR ASSEMBLY PARTS LIST

NUMERO DE NOMENCLATURE
L615
 NUMERO DU DOCUMENT
96/06/02 2/2
Ph. Demeese
 Le chef du bureau d'études

Rep Item	Désignation	Description	Qté. Qty.	CODE	
				STANDARD	
1	Screw		5	41019001	
2	Lock washer		5	45200006	
3	Pin		4	46000416	
4	Repulsion rotor		1	96200026	
5	Bearing		1	56462813	
• 6	Shaft segment		1	47836732	
7	Exhaust washer		1	96200045	
8	Plug		1	96310049	
• 9	O-ring		2	58225929	
10	Rear stop		2	96200069	
11	Bearing		1	56492213	
12	Spacer		1	96310018	
13	Motor rotor assembly		1	96200093	
14	Motor cover		1	9631011742	
• 15	Gasket		1	96310045	
• 16	O-ring		1	58221729	
17	Bearing		1	50600003	
• 18	Nut		1	57000003	
19	Spring		1	69143932	
20	Washer		1	96310054	
21	Screw		1	41103403	
22	Rear stop		1	94120030	
• 23	Nut		1	57000004	
24	Bearing		1	50600004	
25	Stopper		1	96310017	
26	Screw		4	41302206	
27	Motor housing		1	96200097	
• 28	Gasket		1	96310118	
29	Motor housing		1	96310078	
30	Screw		4	41000101	
31	Lock washer		4	45200006	

• Recommended Spare

(Bom.N6150023)

DISASSEMBLY INSTRUCTIONS
(air motor)

1. Stand winch in a vertical position on the rear end cover.
2. Remove the 4 screws which secure the motor to the mounting flange.
3. Remove motor and control valve assembly.
4. Remove the 4 screws which secure the control valve to the motor and remove the control valve.

Air Gear Motor Disassembly

1. Remove the screws (1) and lock washers (2).
2. Remove the motor housing (29).
3. Remove the 'O' ring (16).
4. Remove the gasket (15).
5. Remove screws (26).
6. Remove the motor cover (14).
 - remove the 'O' rings (9).
 - remove the exhaust washer (7) and the plug (8).
 - remove the needle bearings (5 and 11) if they have to be changed.
 - remove pins (3).
7. Immobilize the motor rotors with an pin between the teeth and remove nuts (18 and 23).
8. Remove the motor rotors (13 and 4).
 - remove the shaft segment (6) and the internal ring.
9. Remove the screw (21) and the washer (20).
10. Remove ball bearings (17 and 24).
11. Remove the spacer (12).
12. Remove the stopper (25), the spring (19) and the rear stop (22).

Inspection

- inspect gears and remove nicks or burrs
- inspect and replace bearings if necessary
- inspect motor body and smooth out all nicks or burrs
- inspect the valve and smooth out all nicks or burrs

Air Gear Motor Assembly

Assembly of motor is the same as disassembly in opposite order.

NOTICE

- To correctly assemble the exhaust washer, spacer, valve and the spring, carefully follow instructions:

- Take the motor body and put it in the same position as mounting on the winch and view from the backside of the motor body, stopper, spring, valve and the spacer must be mounted in the left bore. Check for good functioning of the valve.
- The exhaust washer must be mounted on the same side as the valve in the left bore.
- Before assembly lubricate bearing with grade 2 grease.
- Install ball bearings so markings on bearing remain visible.
- After assembly of the air motor, it must turn smoothly in both direction.
- The screws (21 and 26) the nuts (18 and 23) must be secured with LOCTITE ® 243, secure the nuts with a center punch.

INGERSOLL-RAND
MATERIAL HANDLING

Copyright © 1996
Ingersoll-Rand Company
All Rights Reserved

FG05MR19
AIR POWERED
ACCESSOIRES DRAWING

NUMERO DE NOMENCLATURE

L615

NUMERO DU DOCUMENT

96-06-04 1 / 2

Ph. Demeese

LE CHEF DU BUREAU D'ETUDES

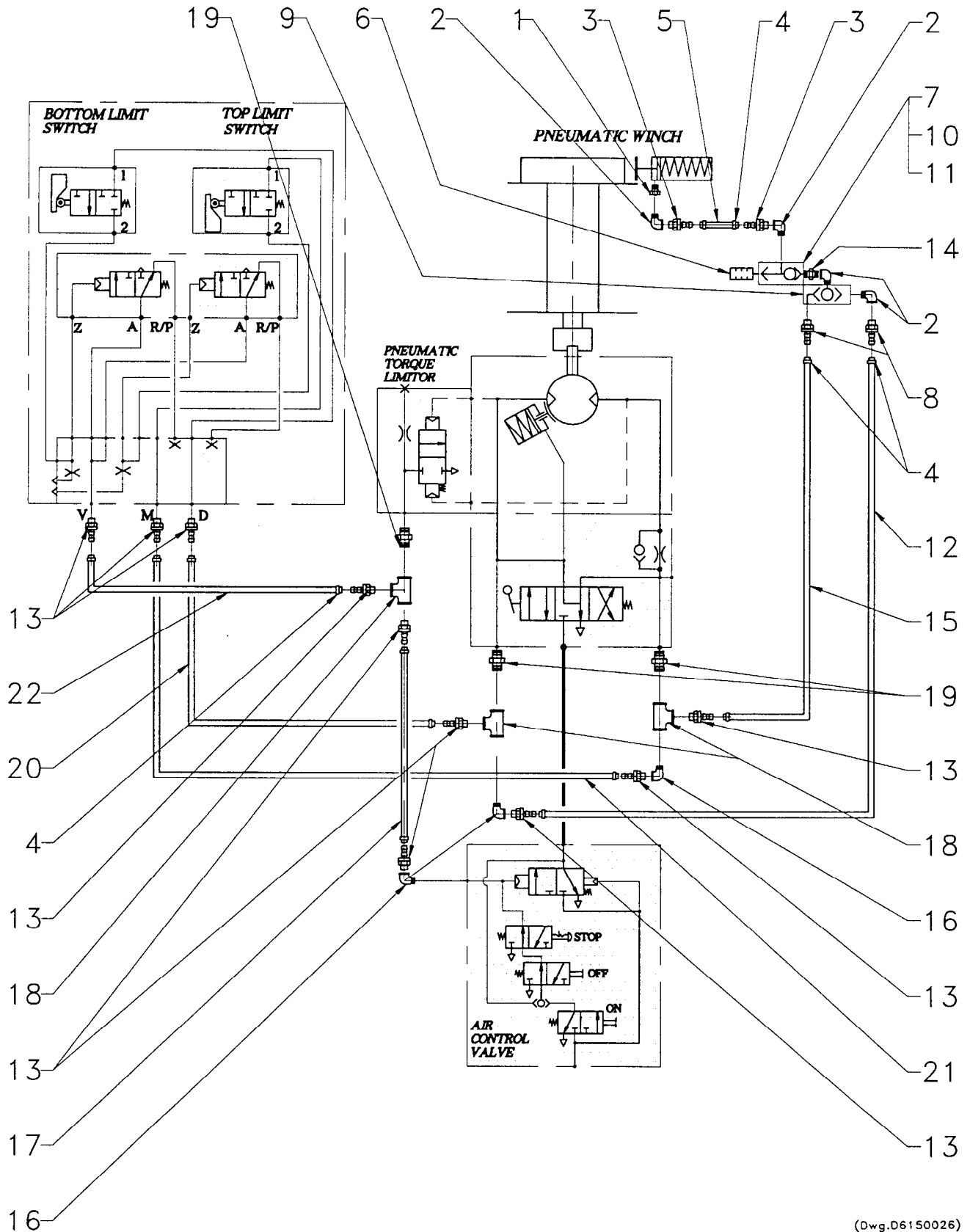

INGERSOLL-RAND
MATERIEL HANDLING
 Copyright © 1996
 Ingersoll-Rand Company
 All Rights Reserved

FG05MR19
AIR POWERED
ACCESSOIRES
PARTS LIST

NUMERO DE NOMENCLATURE
L615
 NUMERO DU DOCUMENT
96/06/04 2/2
Ph. Demeese
 Le chef du bureau d'études

Rep Item	Désignation	Description	Qté. Qty.	CODE	
				STANDARD	
1	Reducing adaptor		1	61308428	
2	Elbow 1/4		4	68235832	
3	Butt-end 1/4 dia.8		2	61635732	
4	Clamp collar		6	61130132	
5	Hose dia.8		m	68055332	
6	Muffler		1	68490832	
7	Quick exhaust valve		1	61935932	
8	Butt-end 1/4 dia.6		2	67709232	
9	Circuit selector		1	67709232	
10	Washer		2	45200005	
11	Screw		2	41014801	
12	Hose dia.6		m	68024232	
13	Butt-end 1/8 dia.6		2	61652632	
14	Nipple 1/4		1	61623132	
15	Hose dia.6		m	68024232	

TORQUE LIMITOR OPTION

4	Clamp collar		2	61130132	
13	Butt-end 1/8 dia.6		2	61652632	
16	Elbow 1/8		1	68280132	
17	Hose dia.6		m	68024232	

LIMIT SWITCH OPTION

4	Clamp collar		6	61130132	
13	Butt-end 1/8 dia.6		6	61652632	
16	Elbow 1/8		2	68280132	
18	Tee 1/8		3	61394532	
19	Nipple 1/8		3	61385232	
20	Hose dia.6		m	68024232	
21	Hose dia.6		m	68024232	
22	Hose dia.6		m	68024232	

INGERSOLL-RAND
MATERIAL HANDLING

DRUM GUARD KIT

NUMERO DE NOMENCLATURE

3615-0040

NUMERO DU DOCUMENT

93,03,02 | A | 1/1

Copyright 1996
Ingersoll-Rand Company
All Rights Reserved

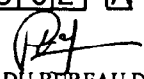
LE CHEF DU BUREAU D'ETUDES

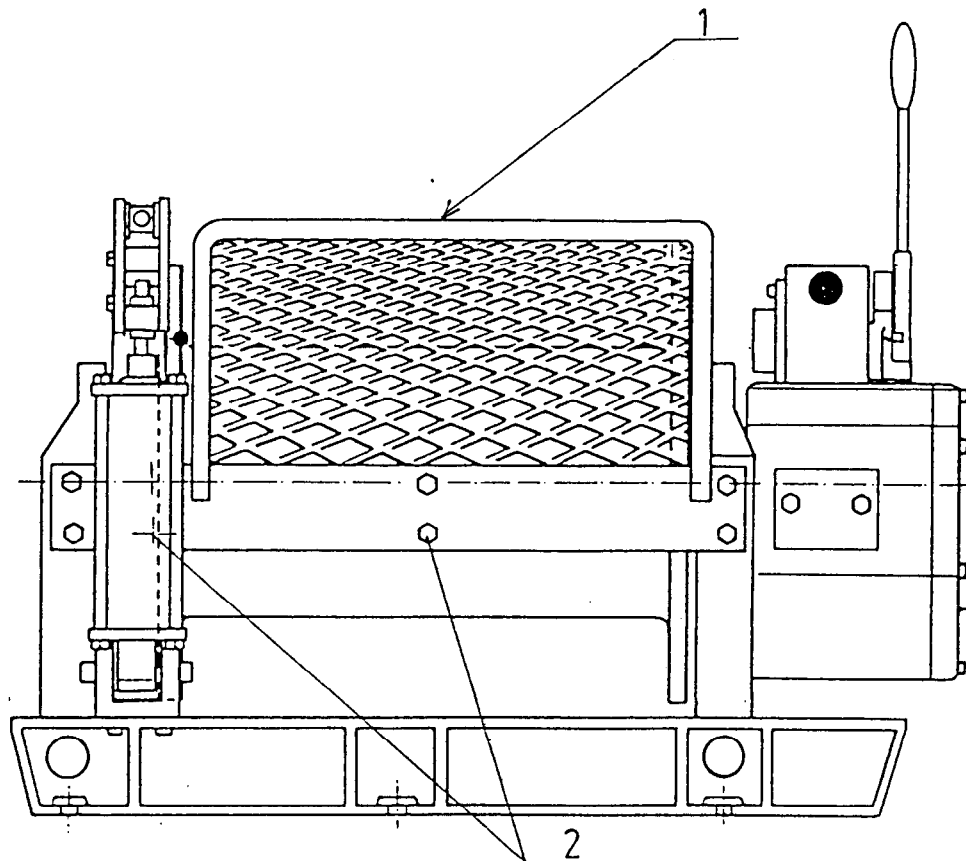

REPÈRE ITEM HINWEIS	DESIGNATION	DESCRIPTION	BEZEICHNUNG	Quantité Quantity Anzahl	CODE	CPN
1	Capot protecteur	Drum guard	Trommelschutzhaube	1	9615-0108	38535753
2	Vis H	Screw	Schraube	4	4100-6201	38535761

Pour toute commande de pièces de rechange, il est recommandé de rappeler le numéro porté sur la plaque d'identification de l'appareil.
For each demand of spare parts, it is recommended to specify the number written on the identification plate of the device.
Bei Bestellung von Ersatzteilen bitte Seriennummer auf dem Identifizierungsschild des Geräte angeben

INGERSOLL-RAND
MATERIEL HANDLING

Copyright © 1996
Ingersoll-Rand Company
All Rights Reserved

FIN DE COURSE PNEUMATIQUE
PNEUMATIC LIMIT SWITCH

NUMERO DE NOMENCLATURE

L615

NUMERO DU DOCUMENT

95/10/20 1/2

Ph. Demcose

Le chef du bureau d'études

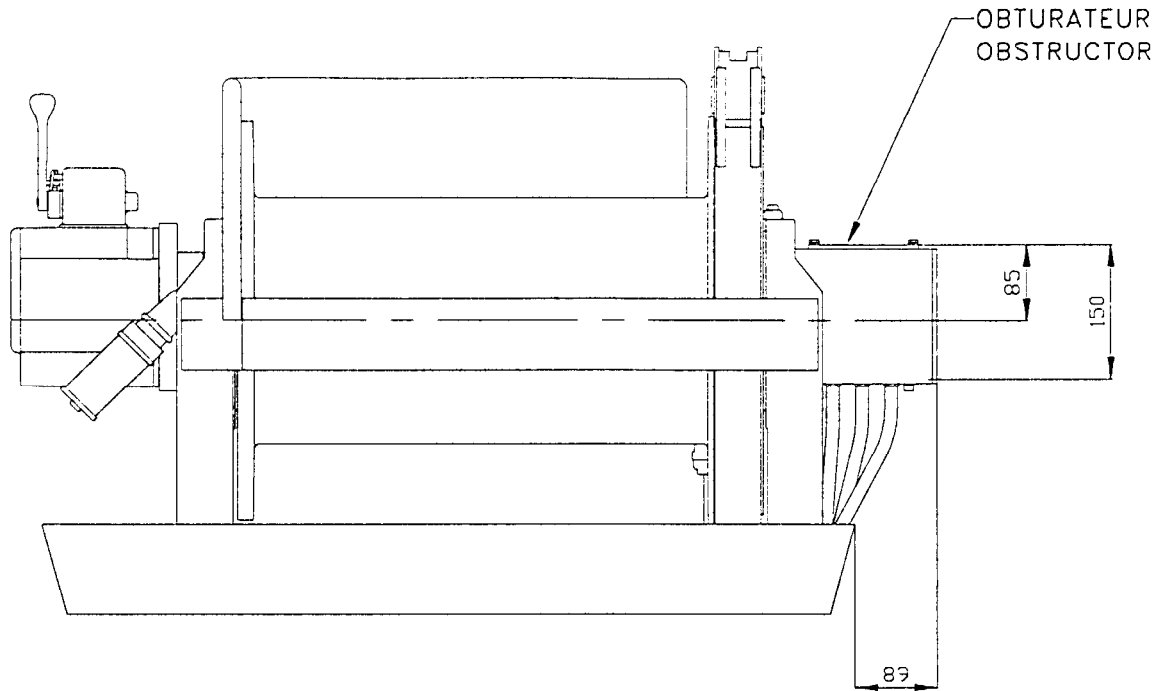

(DWG.D6150029)

FONCTION

Ce dispositif permet de limiter la course de travail du treuil en deux points dont la position peut être réglée à volonté. Il permet également de garantir les 3 tours morts de sécurité sur le tambour et d'immobiliser le treuil lorsque la position la plus haute des crochets est atteinte.

FUNCTION

This device allows to limit the winch running within two points, the position of which can be adjusted at will. It also allows to guarantee the 3 « dead » safety windings on the drum and to stop the winch when the highest position of hooks is reached.

DESCRIPTION

Deux distributeurs à commande mécanique pilotent deux distributeurs qui commandent la fermeture de la valve d'arrêt d'urgence. Les contacts sont actionnés par un mécanisme réducteur. Le tout protégé par un coffret métallique monté sur le palier arrière, il est lié à la rotation du tambour.

DESCRIPTION

Two mechanical remote control valves pilot 2 main control valves which close the emergency stop valve. The contacts are acted by a gear mechanism. The whole is protected by a metallic box, mounted on the rear bearing. The gear is bound to the drum rotation.

REGLAGE

Afin de régler le dispositif de fin de course, enlever l'obturateur (rep. 2) situé sur la partie supérieure du coffret métallique. Desserrer la vis centrale.

Pour limiter la course en sens montée (réglage du point haut), visser la vis de réglage repérée 2, de même pour limiter la course en sens descente, (réglage du point bas), dévisser la vis repérée 1, rebloquer la vis centrale après le réglage.

ADJUSTMENT

To adjust the limit switch device :

- remove the closing plate (rep. 2) from the top, loosen the central screw.
- to limit the stroke on the upward direction (adjustment of the top limit) screw on the adjusting screw 2
- Also to limit the stroke on the downward direction (adjustment of the bottom limit) , unscrew the adjusting screw 1
- then tighten the central screw to secure the above adjustments.

INGERSOLL-RAND

MATERIEL HANDLING

Copyright © 1996
Ingersoll-Rand Company
All Rights Reserved

PNEUMATIC
LIMIT-SWITCH

NUMERO DE NOMENCLATURE

615

NUMERO DU DOCUMENT

95/10/20 - 2 / 2

Ph. Demese

LE CHEF DU BUREAU D'ETUDES

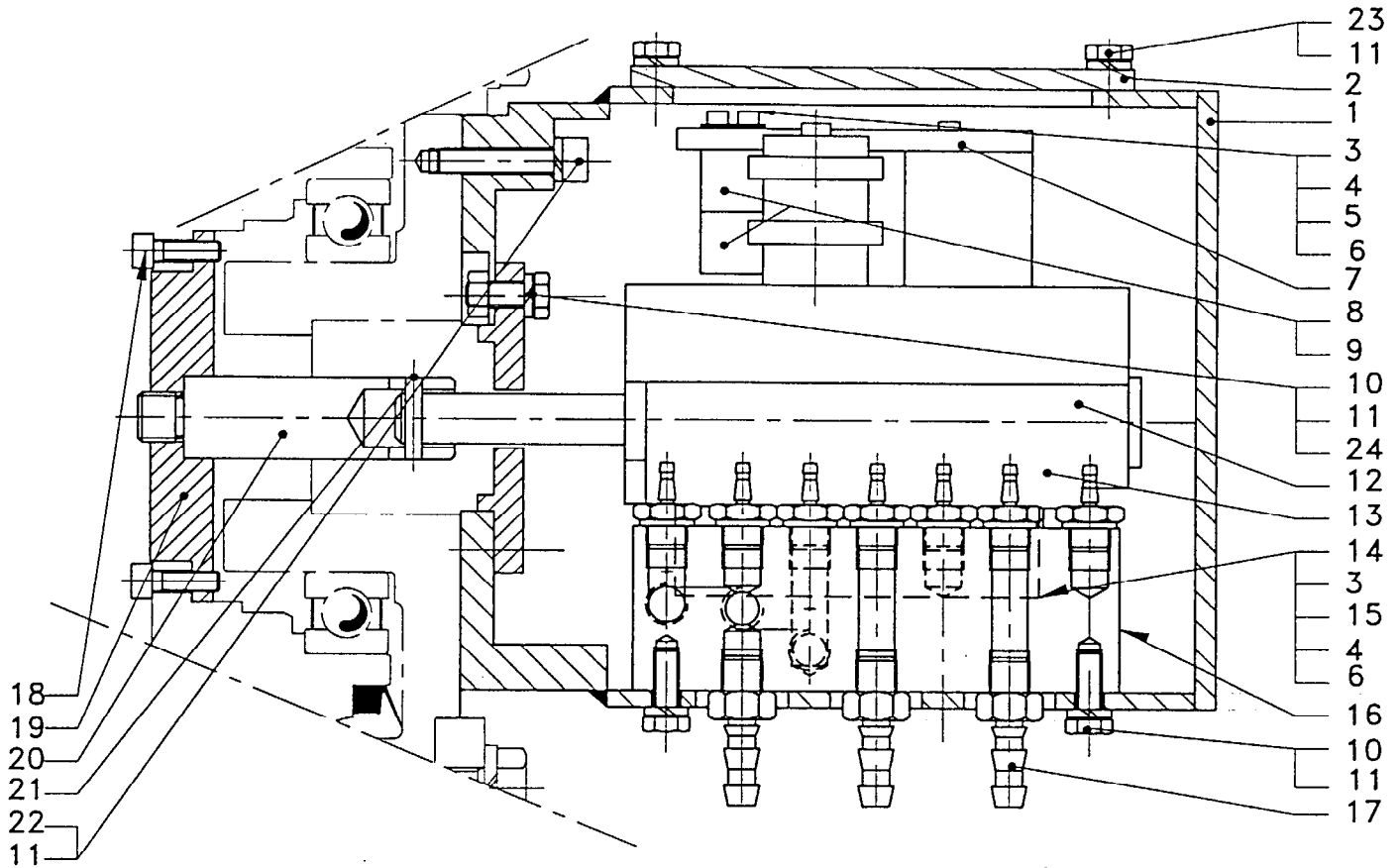

(Dwg.D6150025 A)

REPERE ITEM	DESIGNATION	DESCRIPTION	QUANTITE QUANTITY	CODE PART NO.
1	Coffret	Box	1	96150254
2	Obturateur	Blind washer	1	96150261
3	Vis	Screw	2	41307606
4	Rondelle	Washer	4	45200004
5	Rondelle	Washer	4	45000104
6	Ecrou	Nut	4	43001111
7	Support de distributeur	Support	1	96150255
8	Distributeur	Valve	2	68523641
9	Flexible	Hose	1m	68094832
10	Vis	Screw	5	41000201
11	Rondelle	Washer	7	45200006
12	Fin de course	Limit switch	1	95060150
13	Raccord cannelé	Butt-end	10	61694932
14	Distributeur	Valve	1	68523441
15	Rondelle	Washer	2	45000105
16	Bloc de connection	Connection block	1	96150256
17	About	Butt-end	3	61652632
18	Vis	Screw	4	41308706
19	Rondelle	Washer	1	96150147
20	Axe de liaison	Axle linking	1	96150258
21	Goupille	pin	1	46503420
22	Vis	Screw	2	41300406
23	Vis	Screw	4	41007601
24	Ecrou	Nut	3	43000711

INGERSOLL-RAND
MATERIAL HANDLING

Copyright © 1996
Ingersoll-Rand Company
All Rights Reserved

TORQUE LIMITER
ASSEMBLY
DRAWING AND PART LIST

NUMERO DE NOMENCLATURE

L 636

NUMERO DU DOCUMENT

95-10-19 A 1 / 1

Ph. Demeese

LE CHEF DU BUREAU D'ETUDES

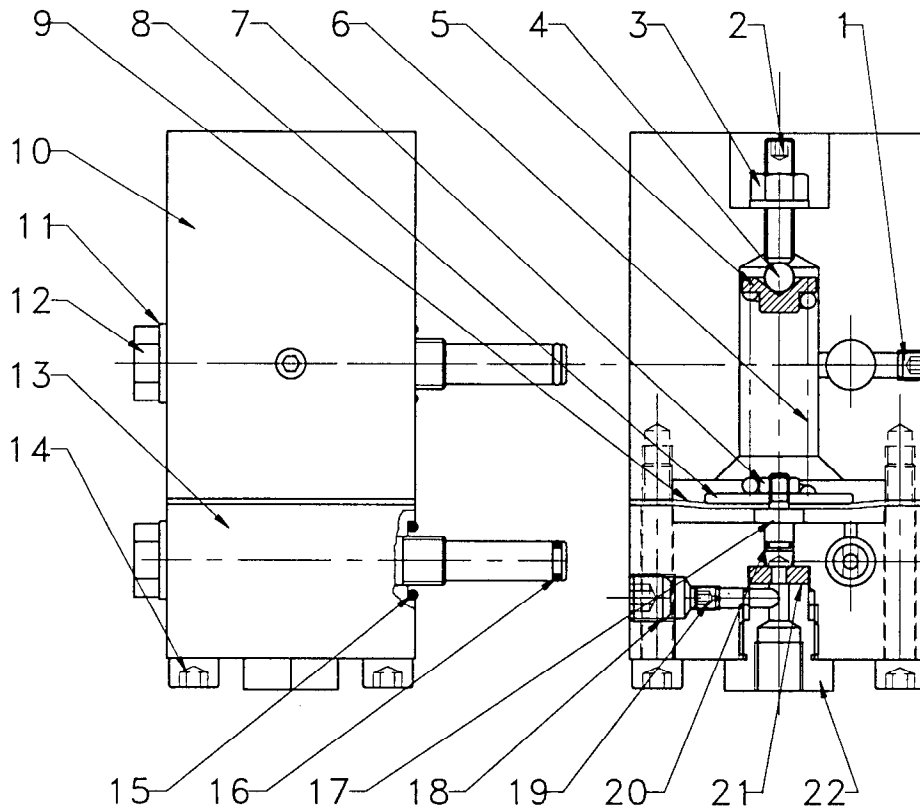

ITEM NO	DESCRIPTION OF PART	QTY TOTAL	PART NUMBER
	Torque limiter (incl's item 1 through 22)	1	36360001
1	Screw	1	42007407
2	Screw	1	42001607
3	Nut	1	43007811
4	Ball	1	69400125
5	Spring seat	1	96360023
6	Spring	1	69118541
7	Nut	1	43001111
8	Washer	1	96360019
9	Diaphragm	1	96360020
10	Cover	1	96360015
11	Joint Usit-ring	2	58409731
12	Screw	2	96360022
13	Body	1	96360016
14	Screw	4	41314906
15	O'ring	2	58210729
16	O'ring	2	58209229
17	Valve	1	96360017
18	Plug	1	65172032
19	Nozzle	1	96170071
20	O'ring	1	58222329
21	Joint	1	96360021
22	Screw	1	96360018

59432

INGERSOLL-RAND
MATERIAL HANDLING

Copyright © 1996
Ingersoll-Rand Company
All Rights Reserved

EMERGENCY STPO VALVE ASSEMBLY DRAWING

NUMERO DE NOMENCLATURE

L 617

NUMERO DU DOCUMENT

95-10-18 A 1 / 2

Ph. Demeese

LE CHEF DU BUREAU D'ETUDES

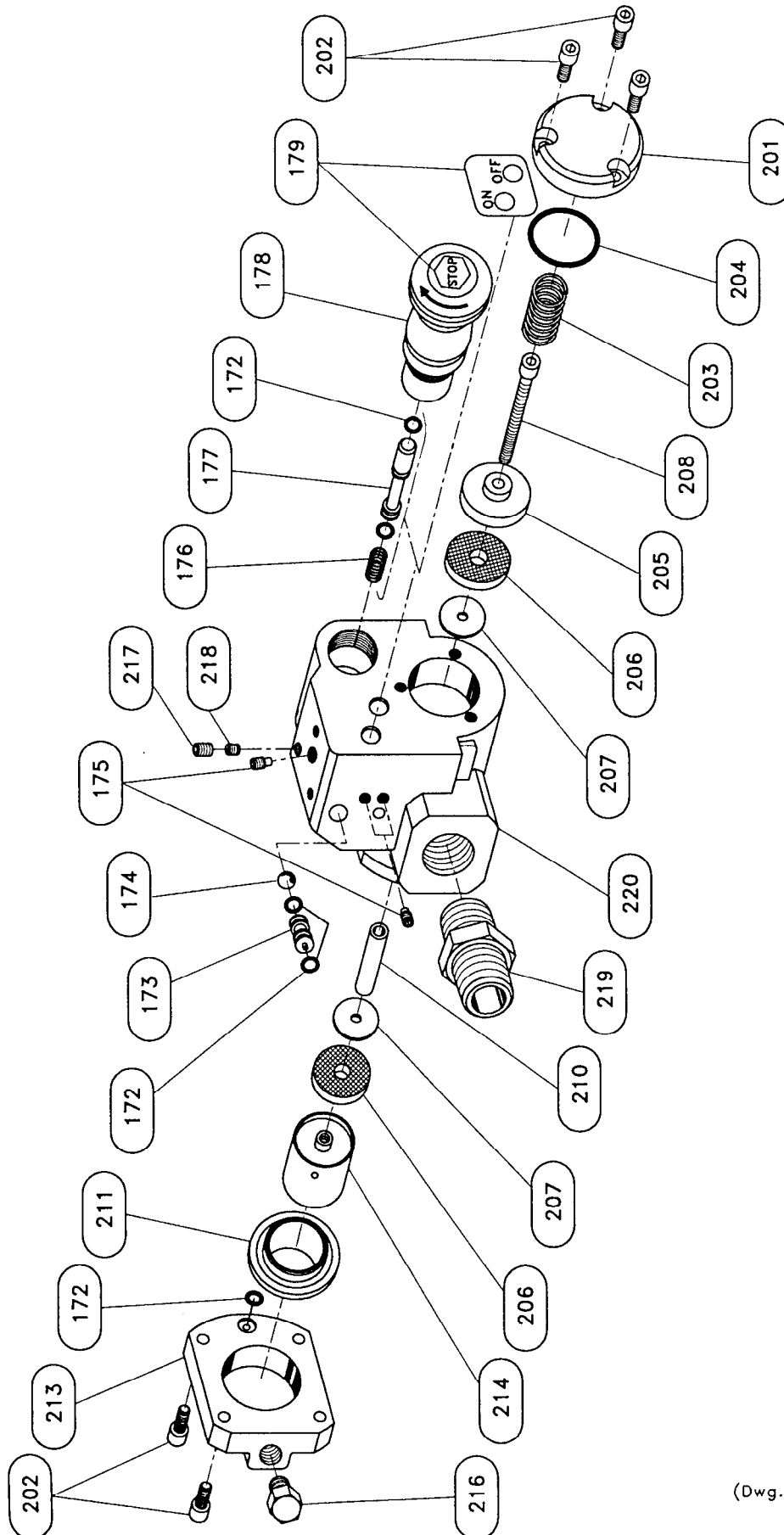

(Dwg.D6170003)

INGERSOLL-RAND MATERIEL HANDLING Copyright © 1996 Ingersoll-Rand Company All Rights Reserved	EMERGENCY STOP VALVE ASSEMBLY PARTS LIST	NUMERO DE NOMENCLATURE 617 NUMERO DU DOCUMENT 95-10-18 A 2/2 <i>Ph. Demeese</i> Le chef du bureau d'études
--	--	---

TEM NO	DESIGNATION OF PART	QTY TOTAL	PART NUMBER	
			1/2 BSP	3/4 BSP
* 172	O' Ring	9	5821-4829	
173	Shuttle Valve Stop	1	9579-0098	
174	Ball	1	6940-1625	
175	Setscrew	3	4200-8207	
176	Spring	3	6911-3941	
177	Spool	3	9579-0085	
178	Emergency Stop Bottom	1	6859-8632	
179	Label Kit	1	9579-0099	
201	Cover	1	9617-0059	
202	Screw	7	4130-6706	
203	Spring	1	6915-8732	
* 204	O' Ring	1	5821-4829	
205	Valve Cone	1	9617-0053	
* 206	Joint	2	9617-0056	
207	Washer	2	4570-0005	
208	Screw	1	4130-8206	
210	Distance Ring	1	9617-0055	
211	Diaphram	1	6771-6341	
213	Cover	1	9617-0052	
214	Valve Cone	1	9617-0054	
216	Plug	1	6517-2032	
217	Setscrew	1	4200-7407	
218	Nozzle	1	9617-0071	
219	Nipple	1	6133-0732	
220	Body	1	9617-0069	9617-0068
221	Emergency stop Valve Assembly (incl's item 172 through 220)	1	3617-0017	3617-0018

 Recommended Spare.

INGERSOLL-RAND
MATERIAL HANDLING

AIR POWERED MAN-RIDING WINCH

NUMERO DE NOMENCLATURE

Copyright 1996
Ingersoll-Rand Company
All Rights Reserved

FG05 MR 19

NUMERO DU DOCUMENT

9,2,0,4,4,2 | A | 1/2

LE CHEF DU BUREAU D'ETUDES

L - PARTS ORDERING INFORMATION

The use of replacement parts other than INGERSOLL-RAND Material Handling will invalidate the Company's warranty. For prompt service and genuine INGERSOLL-RAND Material Handling parts, provide your nearest Distributor with the following :

- 1 - Complete model number with code as it appears on the name plate
- 2 - Part code and part description as shown in this manual.
- 3 - Quantity required.

Return Goods Policy

Ingersoll-Rand will not accept returned goods for warranty or service unless prior arrangements have been made written authorization has been provided from the location the goods were purchased.

NOTICE

Continuing improvement and advancement of design may cause changes to this winch which are not included in this manual. Manuals are periodically revised to incorporate changes. Always check the manual edition number on the front cover for the latest issue.

M - GUARANTEE

See our general conditions of sales mentioned on our proposal, acknowledgement receipt, invoice.

INGERSOLL-RAND guarantees the equipment sold and supplied by itself against any defect or flaw in manufacture or operation under the conditions and within the limits hereafter.

- the guarantee is only valid if the customer has satisfied the general obligations of the present contract and, in particular, of settlement.
- the guarantee is strictly limited to INGERSOLL-RAND equipment. It does extend to supplies and accessories which are not of its manufacture.
- the guarantee does not extend to assemblies or machines in which INGERSOLL-RAND equipment is incorporated and in particular to the performances of these assemblies or machines.
- When INGERSOLL-RAND equipment is incorporated into one or other assembly or machine by the customer, he alone is responsible for the adaptation, the choice and the suitability of the INGERSOLL-RAND equipment, INGERSOLL-RAND 's diagrams, surveys and layouts being given only for guidance, unless there is a special stipulation in the acceptance of order, defined in the acknowledgment of receipt.
- INGERSOLL-RAND does not guarantee components and accessories it does not sell.

Defects in fitting, adaptation, design, connection and running of the assembly or part of the assembly put together by the customer are not covered by the guarantee.

INGERSOLL-RAND equipment and material as well as the assemblies or machines set up by the customer or by a third party are assumed to be operated and used under the sole control of the customer or third party.

- The duration of the guarantee is for 6 months from the start up of the equipment by the customer. The start up must be made at the latest three months after dispatch of the equipment or its being made available.
- INGERSOLL-RAND has the right to demand from its customer proof of the date of start up.
- The guarantee period is reduced to half if the equipment is used day and night.
- The length of guarantee is neither prolonged nor interrupted by either amicable or litigious claims by the customer.
- At the expiry of this period, the guarantee ceases incontestably.
- The obligations of the INGERSOLL-RAND guarantee will only come into effect if the customer proves that the defect or flaw appeared during normal operating conditions for this type of material, or in the

INGERSOLL-RAND
MATERIAL HANDLING

AIR POWERED MAN-RIDING WINCH

NUMERO DE NOMENCLATURE

FG05 MR 19

NUMERO DU DOCUMENT

9,2,0,4,42 | A | 2/2

Copyright 1996
Ingersoll-Rand Company
All Rights Reserved

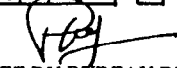
LE CHEF DU BUREAU D'ETUDES

course of normal use as specified by INGERSOLL-RAND.

- It does not apply in the event of user's mistake, negligence, imprudence, faulty superintendence or maintenance, inattention to the instructions or directions for use of low quality lubricants. INGERSOLL-RAND liability is disclaimed for all damage brought about by loss or leaks of oil.
- No guarantee applies either for fortuitous incidents or force majeure, or for wear, replacements or repairs caused by normal use of the equipment.
- The guarantee is restricted to reconditioning in INGERSOLL-RAND's premises at its expense and as soon as possible the equipment and parts recognized as faulty by its technical or after sales services, which are sent carriage paid and packing free, without there being any claim for damage arising, such as injury to personel, damage to property other than that covered by the present contract, loss of possession, of production, commercial detriment or loss of profit.
- During the guarantee period, the cost of labour for dismantling and reassembling equipment outside INGERSOLL-RAND's premises, the cost of moving faulty, replaced or repaired equipment and the travelling and living expenses of INGERSOLL-RAND's engineers are covered exclusively by the customer.
- In order to obtain the advantages of the guarantee, the customer must advice INGERSOLL-RAND without delay and in writing of the defects and flaws in his equipment of which he is complained and furnish proof of their genuine nature. He must give INGERSOLL-RAND or its agents or technicians every facility to verify the defects or flaws and to put them right.
- The guarantee does not apply if the equipment is returned to INGERSOLL-RAND in a condition other than in which it broke down or if the seal has been removed, or if it has been dismantled, repaired or modified by a third party, or by the user or the customer.
- After having been duly informed of the defect or flaw in its equipment, INGERSOLL-RAND will put it right as quickly as possible, whilst reserving the right, in certain cases, to modify the whole or part of the equipment so as to meet its obligations.
- The customer agrees that INGERSOLL-RAND will not be responsible for damage in the event that the customer has not fulfilled one or other of the obligations set out above.
- Parts replaced free of charge remain the property of INGERSOLL-RAND.
- The guarantee does not apply to wearing parts.

IMPORTANT NOTICE

It is our policy to promote safe delivery of all orders.

This shipment has been thoroughly checked, packed and inspected before leaving our plant and receipt for it in good condition has been received from the carrier. Any loss or damage which occurs to this shipment while enroute is not to any action or conduct of the manufacturer.

Visible loss or damage

If any of the goods called for on the bill of lading or express receipt are damaged or the quantity is short, do not accept them until the freight or express agent makes an appropriate notation on your freight bill or express receipt.

Concealed loss or damage

When a shipment has been delivered to you in apparent good condition, but upon opening the crate or container, loss or damage has taken place while in transit, notify the carrier's agent immediatly.

Damage claims

You must file claims for damage with the carrier. It is the transportation company's responsibility to reimburse you for repair or replacement of goods damaged in shipment. Claims for loss or damage in shipment must not be deducted from the INGERSOLL-RAND invoice, nor should payment of INGERSOLL-RAND invoice be withheld awaiting adjustment of such claims as the carrier guarantees safe delivery. You may return products damaged in shipment to us for repair, which services will be for your account and form your basis for claim against the carrier.

EXTERNAL BAND BRAKE
ASSEMBLY DRAWING

Copyright © 1996
Ingersoll-Rand Company
All Rights Reserved

L615
NUMERO DU DOCUMENT
92-04-08 A 1 / 6
Ph. Demese
LE CHEF DU BUREAU D'ETUDES

- (A) LOCTITE INSTAJOINT 574
- (B) LOCTITE FREIN FILET 243
- (C) LOCTITE TUBETANCHE 577
- (D) SILICOMET

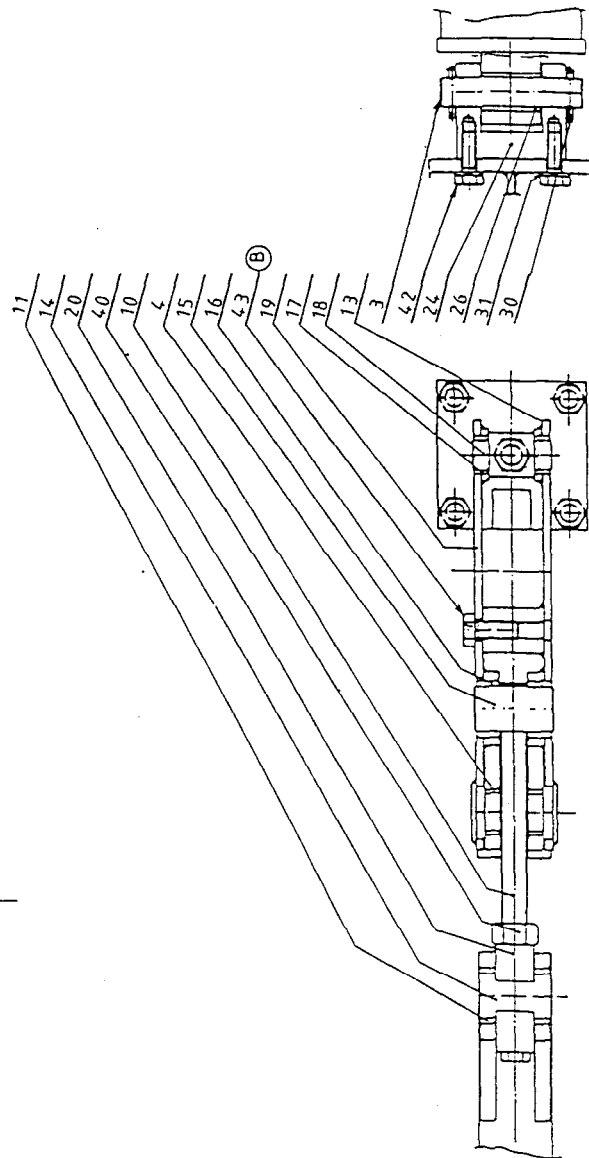
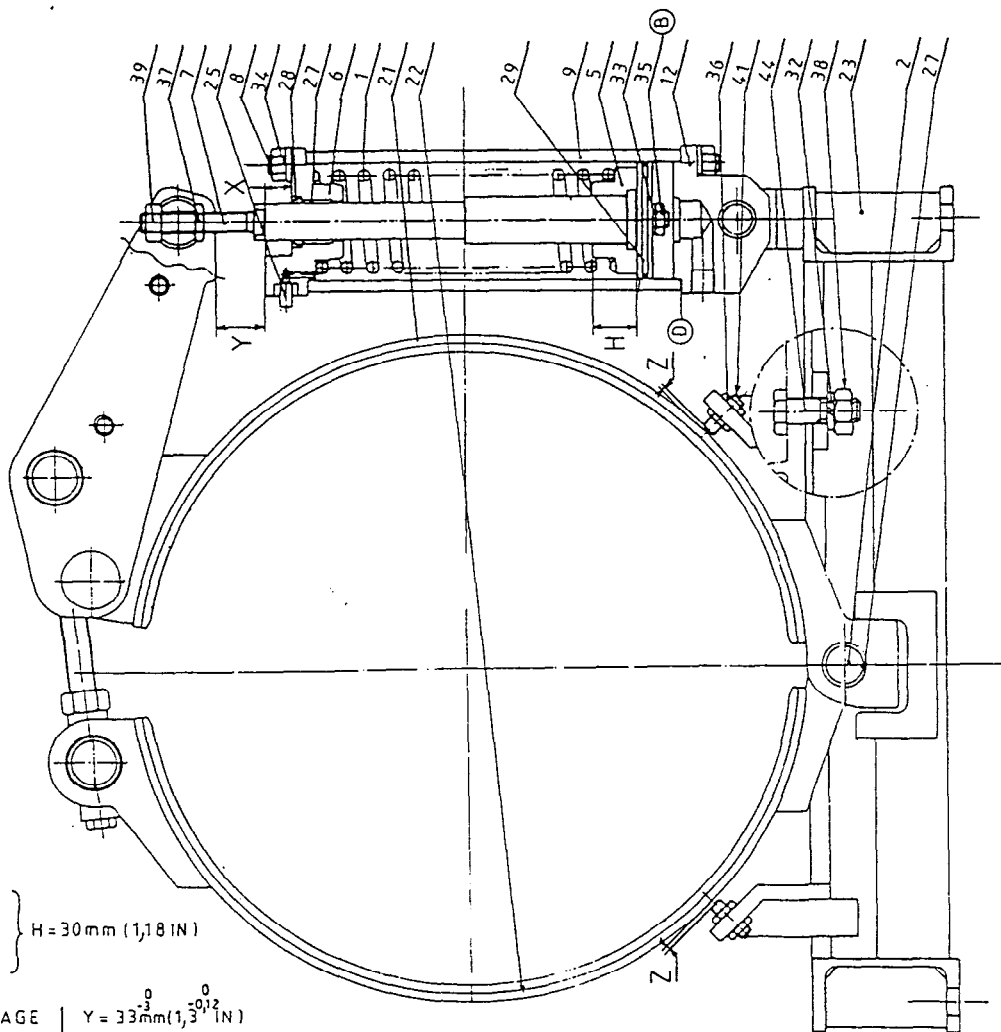

NIVEAU D'HUILE }
Oil level } H = 30 mm (1,18 IN)
Ölstand }

CÔTES DE REGLAGE | Y = 33⁰_{mm} (1,3^{0,12}_{IN})
Adjusting dimensions | X = 18 mm (0,71⁰_{IN})
Passungsmaß | Z = 1,5 mm (0,059⁰_{IN})

FG05MR19
MAN-RIDING WINCH
ASSEMBLY DRAWING

L615	
NUMERO DU DOCUMENT	
96-06-01	1 / 3
<i>Ph. Demesse</i>	
LE CHEF DU BUREAU D'ETUDES	

