

# INSTALLATION AND REPAIR PARTS FOR PLAIN RIGID TROLLEYS

$\frac{1}{2}$  Metric Ton (1100 lbs.)  
3.25" to 5.50" (83 to 140 mm) Flange Width

B-K430 Standard; Taper Tread Wheels

B-K430T Standard; Flat Tread Wheels

B-K1430 Spark-Resistant; Taper Tread Wheels

B-K1430T Spark-Resistant; Flat Tread Wheels

**Always operate, inspect and maintain this Trolley in accordance with American National Standards Institute Safety Code (ANSI B30.11, B30.16) and any other applicable safety codes and regulations.**

**READ ALL INSTRUCTIONS BEFORE INSTALLING, OPERATING OR REPAIRING THESE PLAIN RIGID TROLLEYS.**

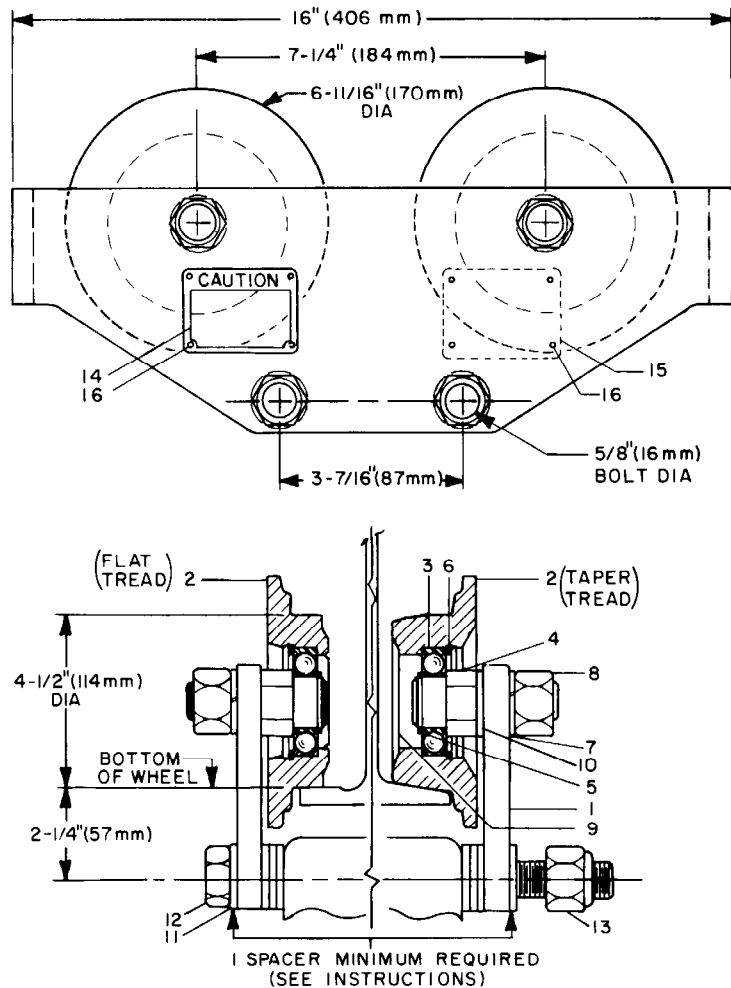

(Dwg. TPD908)

Refer All Communications to the Nearest  
Ingersoll-Rand Office or Distributor.

© Ingersoll-Rand Company 1984

Printed in U.S.A.

**INGERSOLL-RAND®**  
**AIR HOISTS**

## INSTALLING THE TROLLEY

When installing a Trolley on a beam, measure the beam flange and temporarily install the Trolley on the Hoist to determine the exact distribution and arrangement of the spacers. The distance between the wheel flanges should be 3/16" to 1/4" (4.76 to 6.35 mm) greater than the width of the beam flange. The number of spacers between the Trolley side plate and the mounting lug on the Hoist must be the same in all four locations in order to keep the Hoist centered under the I-beam. The remaining spacers must be equally distributed on the outside of the side plate. **Warning: At least one spacer must be used between the bolt head and side plate and nut and side plate. Failure to do so could cause the Hoist to fall when used improperly. Tighten the Trolley Bracket Bolt Nuts to a minimum torque of 150 ft-lb (203.4 N m).**

When installing the Hoist and Trolley on the beam, make certain the side plates are parallel and vertical. After installation, operate the Trolley over the entire length of the beam with a capacity load suspended a few inches off the floor.

## HOW TO ORDER REPAIR PARTS FOR YOUR TROLLEY

Your Trolley is designed and constructed to give you long, troublefree service. In time it may become necessary to order and install new parts to replace those that have been subjected to wear. For prompt service and genuine Ingersoll-Rand parts, place orders with your nearest Ingersoll-Rand Distributor. The use of other than genuine Ingersoll-Rand replacement parts may result in decreased performance, and may invalidate all warranties.

When ordering parts, give your Distributor the following data:

1. Complete model number of the Trolley as it appears on the nameplate.
2. Complete part number, part description and quantity needed as shown below.

### PART NUMBER FOR ORDERING

1	Trolley Side Plate (2)	
	Standard . . . . .	B-430
	Spark-Resistant . . . . .	B-R430
2	Wheel (4)	
	Flat Tread Standard . . . . .	TP3-431T
	Taper Tread Standard . . . . .	TP3-431
	Flat Tread Spark-Resistant . . . . .	TP3-1431T
	Taper Tread Spark-Resistant . . . . .	TP3-1431
3	Bearing (4) (AFBMA No. 35BC02JD) . . . . .	TP223A-160
4	Wheel Shaft (4) . . . . .	TP223A-102
5	Retaining Ring (4) . . . . .	CE210-209
6	Retaining Ring (4) . . . . .	150BM-677
7	Lock Washer (4) . . . . .	D04-960
8	Nut (4) . . . . .	C04-289A
9	Cover (4) . . . . .	CE220-632
10	Washer (4) (required on taper wheels only) . . . . .	TP223A-157
11	Spacer (38) . . . . .	D01-442-1/6
12	Bolt (2) . . . . .	D01-694-9
13	Nut (2) . . . . .	D01-341A
14	Caution Tag . . . . .	TP200-943
15	Nameplate . . . . .	TP200-914
16	Drive Screw (8) . . . . .	R4K-302