

OPERATOR AND MAINTENANCE MANUAL

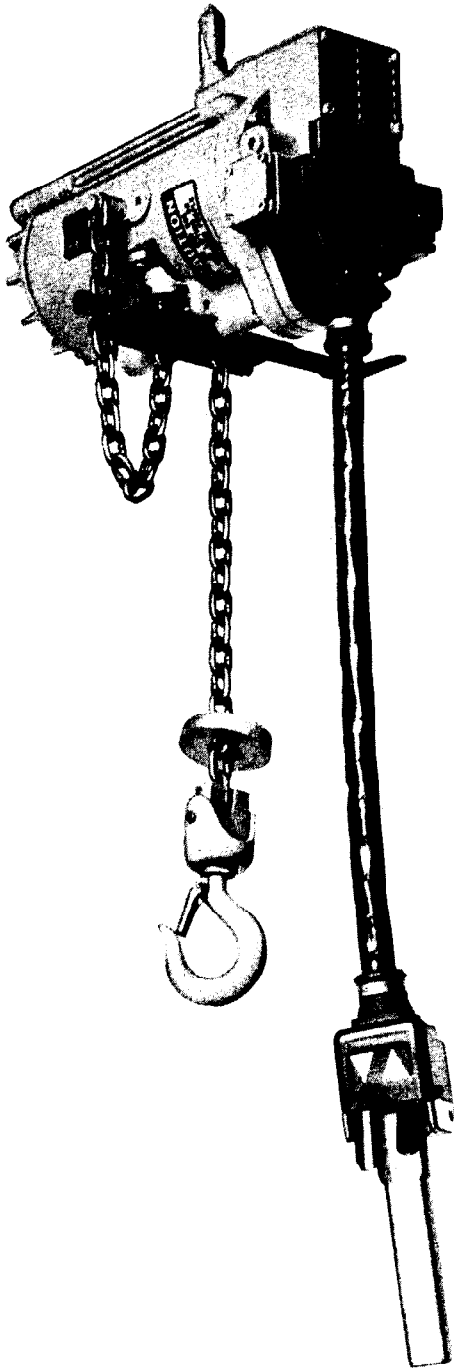

MODEL ML25K
1/4 - Ton Air Chain Hoist

MODEL ML50K
1/2 - Ton Air Chain Hoist

MODEL ML100K
1 - Ton Air Chain Hoist

WARNING
DO NOT USE THIS HOIST FOR
LIFTING OR LOWERING PEOPLE.

ALWAYS OPERATE, INSPECT AND MAINTAIN
THIS HOIST IN ACCORDANCE WITH AMERICAN
NATIONAL STANDARDS INSTITUTE SAFETY
STANDARDS B30.16 .

READ ALL THE ENCLOSED INSTRUCTIONS BEFORE
INSTALLING, OPERATING OR REPAIRING THIS
HOIST.

Refer All Communications to the Nearest
Ingersoll-Rand Office or Distributor.

© Ingersoll-Rand Company 1981

Printed in U.S.A.

INGERSOLL-RAND®
AIR HOISTS

HOW TO ORDER REPAIR PARTS FOR YOUR HOIST

Your Hoist is designed and constructed to give you long, trouble-free service. In time it may become necessary to order and install new parts to replace those that have been subjected to wear. For prompt service and genuine Ingersoll-Rand parts, place orders with your nearest Ingersoll-Rand Distributor. The use of other than genuine Ingersoll-Rand replacement parts may result in decreased Hoist performance, and may, at the Company's option, invalidate all warranties.

When ordering parts, give your Distributor the following data:

1. Complete model number of the Hoist as it appears on the nameplate.
2. Complete part number, part description and quantity needed as shown on the pages of this manual.

If it becomes necessary to return the complete Hoist or certain parts to the factory, contact the Distributor from whom you purchased the Hoist, or the nearest Ingersoll-Rand Distributor in your locality.

INSTALLING THE HOIST

Make certain your Hoist is properly installed. A little extra time and effort in so doing can contribute a lot toward preventing accidents and helping you get the best service possible.

Always make certain the supporting member from which the Hoist is suspended is strong enough to support the weight of the Hoist plus the weight of a maximum rated load plus a generous factor of at least 500% of the combined weights.

When installing a Fabric Chain Container on an MLK Hoist refer to the illustration on Page 30. **Note:** Make certain to adjust the balance chain so that the Container does not contact the load chain.

If the Hoist is suspended by a Top Hook, the supporting member should rest completely within the saddle of the Hook and be centered directly above the hook shank. Do not use a supporting member that cants the Hoist to one side or the other.

For installing a Trolley on a beam measure the beam flange and temporarily install the Trolley on the Hoist to determine the exact distribution and arrangement of the spacers. The distance between the wheel flanges should be $\frac{3}{16}$ " to $\frac{1}{4}$ " (4.76 to 6.35 mm) greater than the width of the beam flange. The number of spacers between the Trolley side plate and the mounting lug on the Hoist must be the same in all four locations in order to keep the Hoist centered under the I-beam. The remaining spacers must be equally distributed on the outside of the side plate.

When installing the Hoist and Trolley on the beam, make certain the side plates are parallel and vertical. After installation, operate the Trolley over the entire length of the beam with a capacity load suspended a few inches off the floor.

LUBRICATION SPECIFICATION

Whenever a Series MLK Hoist is disassembled for overhaul or replacement of parts, lubricate as follows:

1. Coat all motor parts with a light film of Ingersoll-Rand Pneu-Lube® Medium Oil No. 50 or a good quality SAE 20 or 20W motor oil before assembling.
2. Apply a coating of Ingersoll-Rand No. 11 Grease to the Planet Gear Bearings (83) and the Brake Driver Bearing (87) before assembly.
3. Lubricate **each link** of the load chain weekly using a good quality SAE 50 to 90W EP oil. Lubricate the chain more frequently depending on the severity of service.

OPERATION

Always use an air line filter and lubricator with an MLK Hoist. The diameter of the air passage must be at least 1/2" (13 mm). We recommend using No. NFLRU-8 Filter-Lubricator-Regulator installed as close to the inlet of the Hoist as practical.

If quick disconnect fittings are used at the inlet of the Hoist, they must have at least a 3/8" (9.5 mm) air passage. Use of smaller fittings will reduce performance.

OPERATING PRACTICES

The two most important aspects of Hoist operation are: (1) Allow only qualified people to operate a Hoist, and (2) Subject each Hoist to a regular inspection and maintenance procedure.

A qualified operator must be physically competent. He must have no health condition which might affect his ability to react, and he must have good hearing, vision and depth perception. The qualified Hoist operator must be carefully instructed in his duties and must understand the operation of the Hoist, including a study of the manufacturer's literature. He must thoroughly understand proper methods of hitching loads. He should have a good attitude regarding safety and should refuse to operate under unsafe conditions.

Proper use of a Hoist begins before a load is lifted. Make certain to:

- a. Check to see that the Hoist is directly over the load. Do not lift the load at an angle.
- b. Check to see that the Hoist is securely connected to the overhead crane, monorail, trolley or supporting member.
- c. Check to see that the load is securely inserted in the hook.

Regular inspection procedures should be set up, rigidly adhered to and recorded by or under the direction of a qualified person. On Hoists in continuous service, inspection should be made at the beginning of each shift. The items to be checked include, but are not limited to:

- a. Lubrication according to the instructions above.
- b. **Brakes:** Lift a capacity or near capacity load a few inches off the floor and check ability of braking system to stop and hold the load and without excessive drift.
- c. **Chain and Hooks:** Visually inspect the load chain for cleanliness and lubrication as well as wear or other damage. **Note:** Excessive wear may not be apparent upon casual observation. The only positive check is to gauge it according to manufacturer's instructions. Refer to **CHAIN REPLACEMENT** on page 7. Never operate a Hoist with dry, dirty, worn, damaged or kinked chain.

Hooks should be checked for wear, increase in throat opening, and bending. (**Note:** Increased throat opening or a bent hook indicates overloading or abuse). Replace hooks having a 15% increase in throat opening or 10% bend. If the hook latch snaps past the tip of the hook, the hook is sprung and must be replaced. Check hook support bearings for lubrication or damage. See that they swivel easily and smoothly.

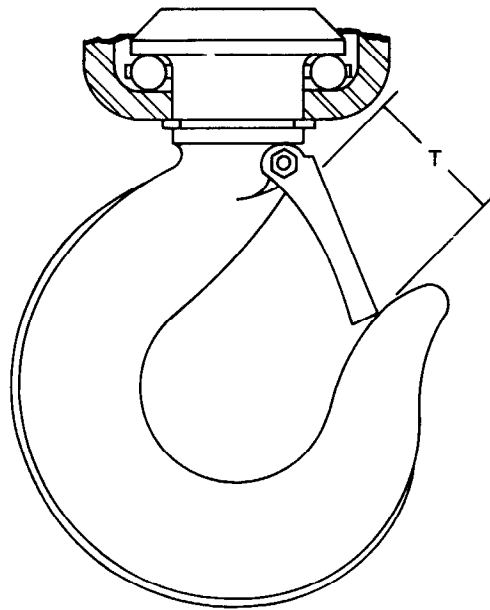

(Dwg. TPD450)

Hoist Size	"T" Throat Opening			
	New Hook		Discard Hook	
	in	mm	in	mm
For ML25K and ML50K.....	1-1/16	27.0	1-7/32	31.0
For ML100K	1-1/4	31.8	1-7/16	36.5

Observe the action of Chain feeding through the Hoist. Do not operate a Hoist unless the Chain feeds through the Hoist and Hook Block smoothly and without audible clicking or other evidence of binding or malfunctioning.

- d. **Controls:** See that the controls function properly and return to neutral when released. Check the functioning of up and down stops by running the empty hook slowly to both extremes of travel. If the hook does not stop in its normal position, do not operate the Hoist until the cause of the trouble is located and corrected.
- e. **General:** Check to see that suspension fastenings are secure, unworn and undamaged. On trolley-mounted Hoists, check that trolley wheels track the rail properly and that wheels and rail are not excessively worn. Be alert for unusual visual or audible signs which could indicate a defect. Do not operate the Hoist until the defect has been determined and corrected.

Periodically, depending upon severity of service, the following items should also be inspected. These are in addition to those previously listed.

- a. Check all load-supporting members, including Chain, Pocket Wheel and Chain Guides, for excessive wear or damage.
- b. Inspect top and bottom hooks with a magnetic particle or other suitable crack detector.
- c. Hook retaining nuts or collars along with their locking members and support bearings should be inspected. Proper inspection will require disassembly.
- d. Check and clean the brake parts each time the Hoist is disassembled. Replace the brake disc if the thickness is less than .090 in (2.286 mm).
- e. At least once yearly disassemble the Hoist and check for worn gearing, bearings and shafts. The parts should be cleaned, lubricated and reassembled. Replace worn parts.
- f. Check all Trolleys for smoothness of operation and for wear on supporting members.
- g. Check for excessive wear in the fabric in a Fabric Chain Container, and check for loose mounting bolts and nuts on Fabric and Metal Chain Containers.

OPERATING INSTRUCTIONS

1. Read the manufacturer's operating instructions before operating the Hoist.
2. Never lift a load greater than the rated capacity of the Hoist.
3. Never use the load chain as a sling.
4. Never operate the Hoist with twisted, kinked or damaged chain.
5. Be certain the load is properly seated in the saddle of the hook. Faulty loading leads to spreading of the hook.
6. Do not use load chains as a ground for welding. Do not attach a welding electrode to a Hoist or sling chain.
7. Do not use the up and down stops as means of stopping a Hoist—these are emergency devices only. Keep hands and clothing free from the throttle lever.
8. Do not leave a load suspended for any extended period.
9. Always stand clear of the load.
10. Never use the Hoist for lifting or lowering people, and never stand on a suspended load.
11. Never carry loads over people.
12. Before each shift, check the Hoist for wear or damage. Check brakes, limit stops, etc.
13. Periodically inspect the Hoist thoroughly and replace worn or damaged parts.
14. Follow the lubrication instructions.
15. Do not attempt to repair load chain or hooks. Replace them when they become worn or damaged.
16. Never operate a Hoist when the load chain is not centered under the hook. Do not "side pull" or "yard".
17. Always rig the Hoist properly and carefully.
18. Ease the slack out of the load chain when starting a lift. Do not jerk the Hoist.
19. Keep the load chain clean and well lubricated. Do not drag the load chain or hook on the floor.
20. Be certain there are no objects in the way of a load or hook when moving the Hoist.
21. Be certain the air supply is shut off before performing maintenance work on the Hoist.
22. Avoid swinging the load when moving the Hoist.
23. Keep the load block overhead when not in use.
24. Properly secure an outdoor Hoist before leaving it unattended.
25. Do not allow unqualified personnel to operate a Hoist.
26. Avoid collision or bumping of Hoists. Do not swing a suspended load.
27. Do not operate a Hoist if you are not physically fit to do so.
28. Do not do anything that you feel may be unsafe.
29. Pay attention to the load at all times when operating a Hoist.
30. Never splice a hoist chain by inserting a bolt between links or by any other means.
31. Do not force a chain or hook into place by hammering, and never insert the point of the hook into a chain link.
32. Do not allow the chain to be exposed to extremely cold weather. Do not apply sudden loads to a cold chain.

CHAIN LUBRICATION

The load chain and chain attachment pins must be kept clean and lubricated at all times. Unlubricated Chain will wear out in a very few capacity lifts. Failure to maintain clean lubricated Chain will void the Manufacturer's Warranty and cause chain wear which will make operation of the Hoist hazardous. Use an open chain lubricant or any good EP gear oil. Several excellent types of open chain lubricants are available and can be purchased in convenient aerosol cans.

CHAIN REPLACEMENT

Excessive Chain wear cannot be detected by casual observation. The Chain is case hardened to a depth of .010" to .012", and once this case is worn through, wear will progress rapidly and the strength of the Chain will be considerably reduced. Further, the Chain will no longer fit the Chain Wheel properly, greatly increasing the chance of malfunction and Chain breakage.

Periodically, as experience dictates, examine the Chain for wear. Be certain to inspect that portion of the Chain which regularly passes over the Chain Wheel, since this is the portion that suffers the greatest wear. Check the individual links for striation—that is, minute parallel lines indicating excessive stress or wear.

Suspend a light load (50 to 100 pounds) from the Hoist and measure the Chain over the outside of the specified number of links.

The Chain must be measured over its entire working length—that is, over that portion of Chain which continuously passes over the Chain Wheel. When any number of links in the working length reaches or exceeds the discard length, replace the entire Chain. **Always use a genuine Ingersoll-Rand replacement Chain. Never use any other Chain.**

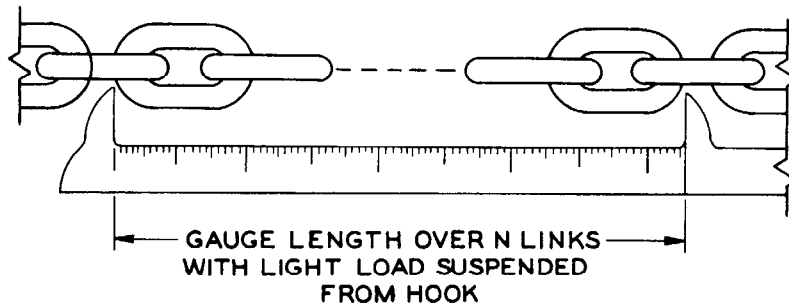

(Dwg. TPD635-1)

DIMENSIONS OF LINK - INCHES				N NUMBER OF LINKS	DISCARD LENGTH OVER N LINKS, INCHES
NOMINAL WIRE DIAMETER	PITCH	INSIDE WIDTH	OUTSIDE WIDTH		
1/4	.767	.298	.823	7	5.89

One Chain Wheel will outlast several Chains if the Chain is replaced as recommended, whereas the use of a worn Chain will cause the Chain Wheel to wear rapidly.

If the Chain is visibly damaged, examine the Chain Wheel and Chain Guard. Install a new Chain Wheel if the old one is visibly worn; install a new Guard if the old one is broken or distorted.

CHAIN REPLACEMENT (Continued)

For Single Line Hoists, Method 1

1. Remove the Brake Spring and Piston Housing, Brake Discs and Brake Plates to expose the Brake Driver.
2. Engage the first link of chain in a pocket of the pocket wheel **FLAT SIDE DOWN**. The weld on the second link must face away from the pocket wheel.

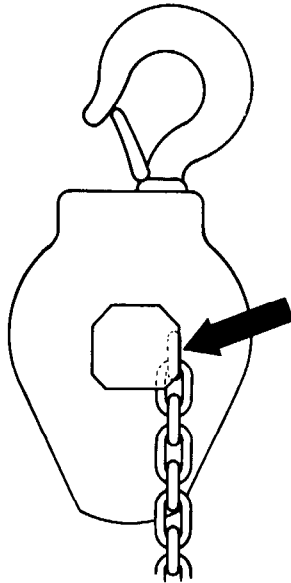

(Dwg. TPD571)

3. Rotate the Brake Driver by hand to thread the chain through the Hoist.
4. Keep the chain straight and do not twist it. Attach the free end of the chain using the chain anchor bolt, washers and spacer. Clean the brake parts and inspect them for excessive wear before assembling.

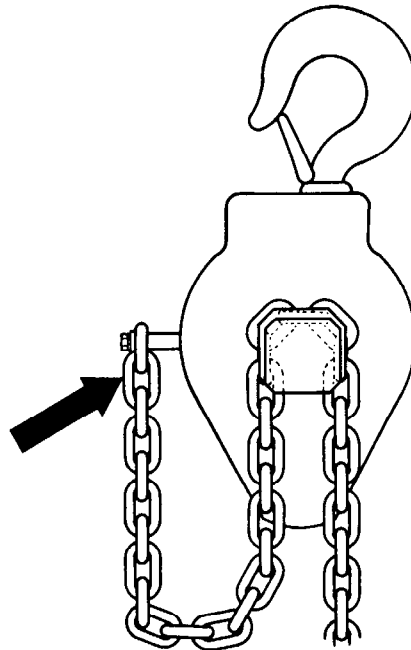

(Dwg. TPD572)

For Double Line Hoists, Method 1

WARNING: THE REPLACEMENT CHAIN FOR A SERIES MLK DOUBLE LINE HOIST MUST HAVE AN EVEN NUMBER OF LINKS.

1. Install the load chain through the Hoist pocket wheel as in Step 1 of the instructions for single line Hoist and attach the end of the chain to the Hoist using the anchor bolt and fasteners. Keep the chain straight.
2. Make certain the load chain is straight and feed the end through the bottom hook wheel with the first link ON EDGE.

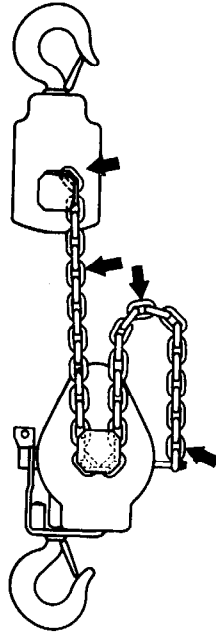

(Dwg. TPD573)

3. Keep the chain straight and attach the free end to the chain anchor bracket.

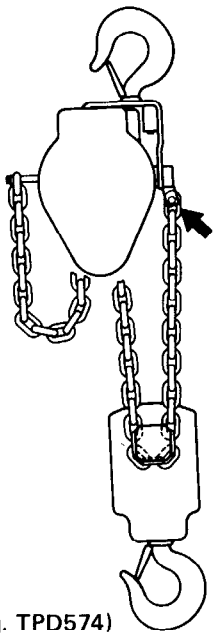

(Dwg. TPD574)

WARNING:
Make Certain That The Bottom Hook
Block Has Not Been Flipped Through
The Chain With A Resultant Twist

Appearance Of
Chain That Has
Not Been Twisted

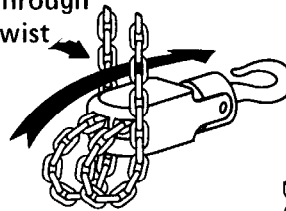
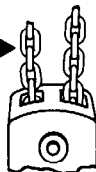

Appearance Of
Chain That Has
Been Twisted

(Dwg. TPD575)

Method 2

1. On ML25K and ML50K single line Hoists, disconnect the load end of the Chain from the hook block. On ML100K double line Hoists, disconnect the load end of the Chain from the chain yoke and withdraw it from the hook sheave block. Do not remove the Chain from the Hoist.
2. Using an abrasive wheel, cut a section from the last standing link as shown in the following illustration. **Caution:** Do not distort the link in any manner. It must be able to pass over the Pocket Wheel without binding.

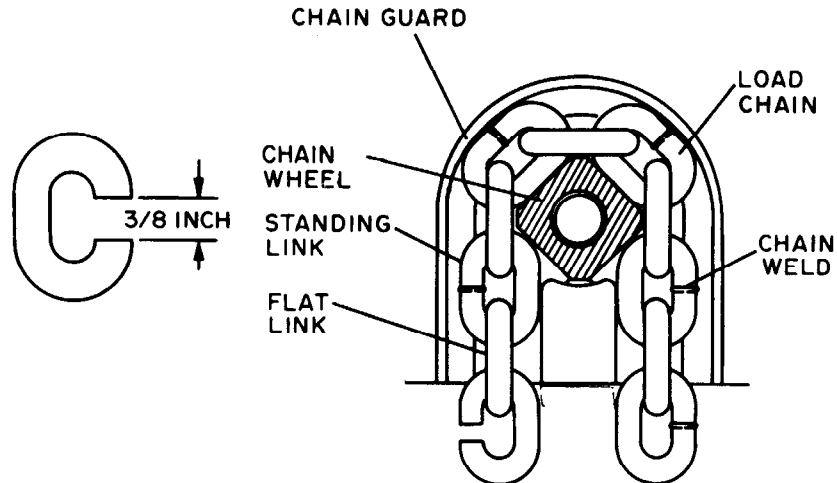

(Dwg. TPD451-2)

3. Connect the new Chain to the old Chain by hooking the end of the new Chain onto the cutaway link. Make certain the welds on the standing links—links perpendicular to the Pocket Wheel—face away from the Pocket Wheel.
4. Carefully energize the Hoist in the raise direction, running off the old Chain and reeving the new Chain over the Pocket Wheel. The first link of new Chain over the Pocket Wheel must be a flat link.
5. After the new Chain is installed, secure the dead end of the Chain to the side of the Hoist. Make certain there is no twist in the dead end of the Chain between the Pocket Wheel and the end link. A twisted Chain can jam as it passes over the Pocket Wheel, possibly resulting in damage to the Hoist or even breaking the Chain and injuring personnel.
6. On single line Hoists, install the Stop Ring on the second link from the load end of the Chain, or so a load does not hit the Chain Container, and then attach the Hook Block Assembly.
7. On double line Hoists, reeve the load end of the new Chain around the Pocket Wheel in the Sheave Block Assembly, making certain the Chain is not twisted between the Hoist and Sheave Block.
8. Keeping the load end of the Chain straight, attach the end link to the Chain Anchor.
9. Lubricate the Chain as instructed in the section **CHAIN LUBRICATION**.
10. Run the hook up and down several times under power with no load to make certain the Chain is running smoothly over the Pocket Wheel. There must be no apparent binding or evidence of malfunctioning.

DISASSEMBLY

WARNING: DISCONNECT THE AIR SUPPLY HOSE BEFORE PERFORMING MAINTENANCE ON THIS HOIST.

Note: Refer to the illustrations on the following pages. Disassemble the Hoist only as far as necessary to service the worn or broken component.

1. The Brake Piston (99) located in the Piston Housing (96) may be serviced by removing the Plate Screws (104), Plate (103), Shoulder Bolts (105) and Lock Washers (106).
2. Place the Piston Housing Assembly and Pressure Plate (98) down on a press table. Compress the Springs between the Pressure Plate and the Housing and remove the Piston Nut (102). **WARNING: Release the pressure of the Springs carefully.**
3. Push the Brake Piston (99) from the Housing.
Note: It is necessary to remove the Brake Driver Retainer (67) before the motor components can be removed.
4. Remove the Muffler Cover Screws (33) and the Valve Chest Cover Screws (45).
5. Remove the Valve Chest Screws (19) and remove the Valve Chest (16) from the Housing (1). **Note:** The Throttle Disc Seals (58) and Seal Expanders (59) are free to fall from the Throttle Disc (57) as the Valve Chest is removed.

ASSEMBLY

Before assembling the Hoist clean and apply a light film of oil or grease where specified, to each part. Apply a thin film of O-ring lubricant to each O-ring before final assembly. Clean and lubricate the load chain each time maintenance is performed in addition to the regular maintenance schedule.

Assembly of Valve Chest End

1. Install the Motor Shaft Front Retaining Ring (66) onto the Motor Shaft (64) and slide the Front End Plate Bearing (75), Front End Plate (74), bearing diameter first, and Rotor (70), small diameter first, onto the Shaft.
2. Apply a light film of oil to each Vane (71), slide one Vane into each slot and slide the Cylinder (72) over the Rotor.
3. Slide the Rear End Plate (69) and Rear End Plate Bearing (68) over the short end of the Motor Shaft and apply the Motor Shaft Rear Retaining Ring (65).
4. Align the holes in the Front and Rear End Plates with the dowel hole in the Cylinder and slide a 1/8" diameter rod 12" long through the aligned parts.
5. Place the Motor Retaining Washer (76), dished (concave) side first, over the Front End Plate and engage the dowel hole with the rod.
6. Slide the long hub of the Motor Shaft into the Housing (1), insert the guide rod into the pilot hole in the Housing and seat the motor.
7. Remove the guide rod and replace it with the Cylinder Dowel (73).
8. Apply the Housing Gasket (9) onto the motor end of the Housing and apply the Valve Plate (60) over the Gasket.
9. Apply a heavy film of O-ring lubricant to the Throttle Disc Seals (58) and the Seal Expanders (59). Insert an Expander, small diameter first, followed by a Seal, into each of the two recesses in the Throttle Disc (57).
10. With the valve ports oriented as illustrated on Page 20, slide the Throttle Disc over the hub of the Rear End Plate.
11. With the Throttle Shaft (34) in place in the Housing (1), slide the Limit Gear (36) onto the keyed end of the Shaft and engage the teeth on the Gear with those on the Throttle Disc.
12. For Hoists equipped with Pull Chain Throttle, apply the Throttle Shaft Spring (42) into the Valve Plate before installing the Limit Gear.
13. For Hoists equipped with Pendent Throttle:
 - a. Install one Pendent Piston Seal (22), cupped side trailing, onto the Pendent Piston (21). Push the Piston through the bore of the Valve Chest to the opposite side and install the remaining Seal cupped side outward.
 - b. Apply the Piston Rod Seal (24) to the Piston Rod (23) and slide the Rod into the bore of the Piston so the ends of the Rod protrude equally beyond the Piston.
 - c. Slide a Piston Spring Retainer (27), small diameter trailing, followed by a Spring (26), over the ends of the Rod.
 - d. Align the hole in the Piston with the slot in the back of the Valve Chest.
 - e. Insert the Piston Drive Pin (25) into the Piston through the slot in the Valve Chest. Install the Piston Cylinder Caps (28).

- f. Align the bolt holes in the Valve Chest with those in the Valve Plate (60) and Housing (1) and retain with Valve Chest Screws (19) and Lock Washers (20).
14. Insert the Muffler Inserts and Muffler (31) into the recesses in the top of the Valve Chest and retain them with the Muffler Cover (32) and Screws (33).
15. For Hoists with Pull Chain Throttle:
 - a. Install a Pipe Plug into each of the three tapped holes in the Valve Chest.
 - b. Apply the Valve Chest Cover Grommet and Valve Chest Cover (44) and retain both with the Valve Chest Cover Screws (45).
15. For Hoists equipped with Pendent Control:
 - a. Install an Elbow (221) in each of the tapped holes in the Valve Chest.
 - b. Slide the Pendent Grommet (231), small diameter first, over the Pendent Bundle.
 - c. Install the air supply hose from the Hose Bundle to the top center Elbow, the “up” hose to the left Elbow and the “down” hose to the right Elbow.
 - d. Insert the Stop Sleeve (227) into the recess in the Valve Chest, align the grooves in the Pendent Grommet with the slot in the Valve Chest Cover (44) and retain them using the Cover Screw Washers (46) and Valve Chest Cover Screws (45). **Note:** The Stop Sleeve must be firmly crimped onto the Pendent Bundle cable.
 - e. Clean the Bundle and Grommet to remove all grease and oil.

Assembly of Chain Wheel, Brake and Gearing

1. Apply the Chain Wheel Plain End Washer (79) onto the plain end of the Chain Wheel (77) and press the Bearing (78) onto the Chain Wheel hub.
2. Similarly install the Splined End Chain Wheel Washer (81) and Bearing (80) on the splined end of the Chain Wheel.
3. Slide the Chain Wheel, plain end first, over the end of the Motor Shaft (64) into the brake end of the Housing (1). Tap the assembly to seat the Plain End Bearing (78).
4. Install two Planet Gear Bearings (84) into each of the Planet Gears (83) using Bearing Inserting Tool No. 45675. **Caution:** Lubricate the Bearings as instructed on Page 4 and press only on the hardened stamped end of the Bearing.
5. Install the Planet Gears using the Planet Gear Shaft (86) and Thrust Washers (85).
6. Insert the Brake Driver Bearing (88) in the smooth bore of the Planet Gear Frame (82). **Caution:** Lubricate the Bearing as instructed on Page 4 and press only on the hardened stamped end.
7. Press the Gear Frame Bearing (87) onto the bearing diameter of the Gear Frame. Lubricate as above.

8. **Caution:** It is very important that the Planet Gears and Ring Gear (89) be timed when the Gear Frame Assembly is inserted into the Ring Gear. Time the gearing as follows:
 - a. Align the bolt holes in the Ring Gear and Brake Housing (91) and press in the Ring Gear.
 - b. Stand the Ring Gear and Housing upright.
 - c. Align the arrows and scribe lines on the faces of the Planet Gears in a straight line as illustrated below.

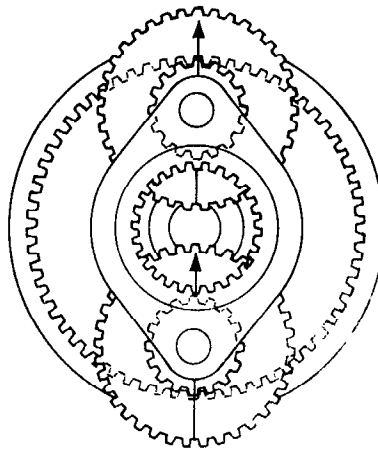

(Dwg. TPD35-1)

- d. Maintain this alignment, insert the Gear Frame Assembly into the Ring Gear and simultaneously press the Planet Frame Bearing into the Brake Housing.
 - e. Make certain the Gasket (90) is in place and install the assembled Planet Frame, Ring Gear and Brake Housing over the Motor Shaft and into the Housing. The Motor Shaft must turn freely by hand. The gear train and Chain Wheel must rotate smoothly as the shaft is turned.
9. Install the Brake Driver (93) and Brake Driver Retaining Ring (67).
10. Stack the brake components over the Brake Driver and into the Brake Housing as illustrated on Page 16. Align the notches in the Brake Plates with the bolt holes in the Brake Housing (91) and main Housing (1).
11. Assemble the Brake Spring and Piston Housing Assembly as follows:
 - a. Apply O-ring lubricant to the Large Seal (100) and Small Seal (101) and install them in their respective grooves on the Brake Piston.
 - b. Taking care not to cut the Seals (100 and 101), slide the Piston into the Brake Spring and Piston Housing (96).
 - c. Place the Spring and Piston Housing (96) on a bench, three spring holes facing upward.
 - d. Place a Spring (97) in each of the holes and place the Pressure Plate (98), stud first, over the Springs and into the Brake Piston.
 - e. Hold the Plate and Housing together and flip the Housing over with the threaded stud up.
 - f. Press down on the Brake Spring and Piston Housing to force the threaded stud through the Piston. While maintaining this position, tighten the Piston Nut (102) to 50 to 70 in-lb (5.65 to 7.91 N m) torque. **Note:** Make certain the Piston is fully inserted through the Spring and Piston Housing and that it is in full contact with the Pressure Plate.
 - g. Install the Plate (103) using the Plate Screws (104).
 - h. Align the bolt holes in the Brake Spring Housing with those in the Housing (1) and install the Lock Washers (106) and Shoulder Bolts (105).

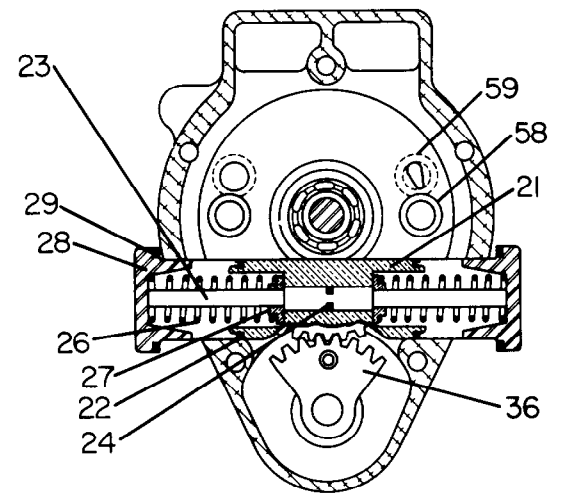
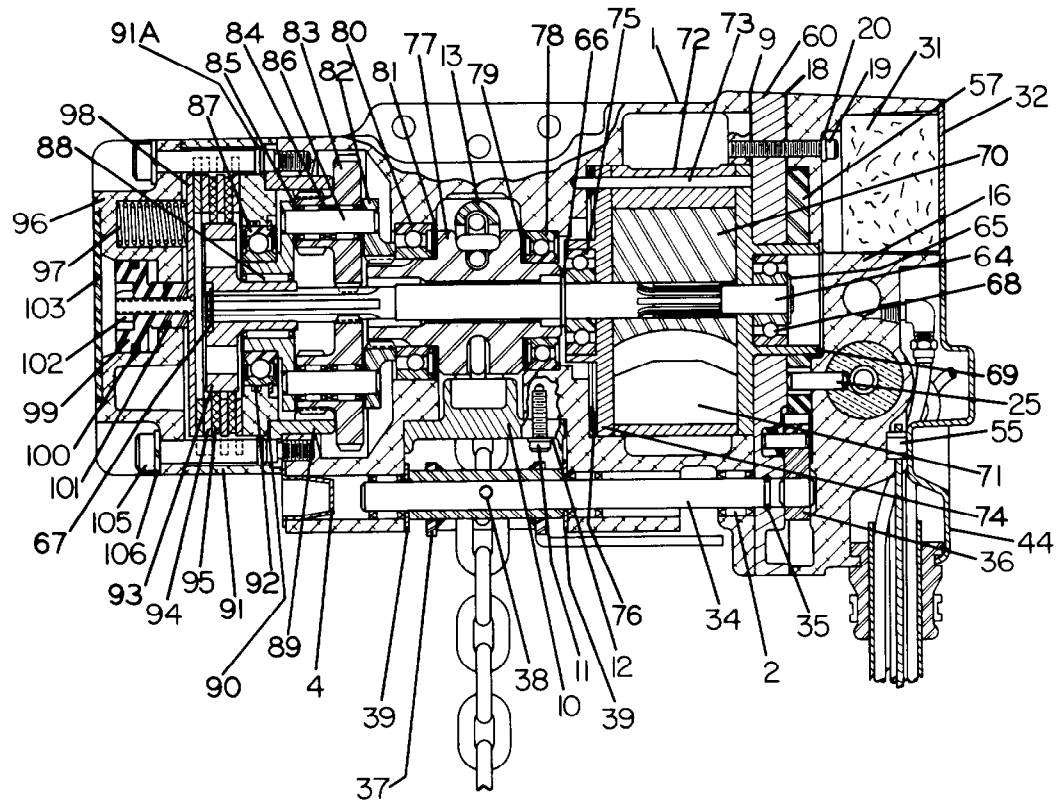

END VIEW OF MLK HOIST WITH
PENDENT THROTTLE

MLK Hoist with Pendent Throttle

(Dwg. TPA715-2)

PART NUMBER FOR ORDERING



PART NUMBER FOR ORDERING



	Housing Assembly	ML50K-A300	31A	Muffler Insert (2)	ML50K-675
1	Housing	ML50K-300	32	Muffler Cover	ML50K-342
● 2	Throttle Shaft Bearing (3)	R38M-603	33	Muffler Cover Screw (4)	CE110-354
3	Vent Plug	P250-546	34	Throttle Shaft	ML50K-A255
4	Throttle Shaft Plug	ML50K-29	● 35	Throttle Shaft Seal	834-159
*	Nameplate	MR-301	36	Limit Gear	ML50K-251
*	Nameplate Screw (4)	R4K-302	37	Throttle Lever	ML50K-556
*	Caution Tag	TA-147A	38	Throttle Lever Retaining Pin	WF171-15
*	Caution Tag Screw (4)	9BM-302	39	Throttle Lever Thrust Washer (2)	MR-458
● 9	Housing Gasket	ML50K-445	*	S-Hook (for Hoists with Pull Chain Throttle (4)	D02-421
10	Chain Guide	ML-741C	*	Pull Chain (for Hoists with Pull Chain Throttle) (2)	MR10-413-10
11	Chain Guide Screw (4)	34U-463	● 42	Throttle Shaft Spring (for Hoists with Pull Chain Throttle)	ML50K-412
12	Lock Washer (4)	4U-58	*	1/8" Pipe Plug (for Hoists with Pull Chain Throttle) (3)	R2-227
13	Chain Guard	ML-6A	44	Valve Chest Cover	ML50K-241
*	Guard Retaining Screw (2)	G57T-634	45	Valve Chest Cover Screw (4)	CE110-354
*	Lock Washer (2)	L01-67	46	Cover Screw Washer (4)	MF-37
16	Valve Chest	ML50K-545	*	Valve Chest Cover Grommet (for Hoists with Pull Chain Throttle)	ML50K-377
17	Valve Chest Inlet Plug	GA57-95	*	Warning Plate	CA110-598
● 18	Valve Chest Gasket	ML50K-928	*	Warning Plate Fastener (2)	CE110-4
19	Valve Chest Screw (5)	PR22H-548	55	Stop Sleeve	ML50K-520
20	Lock Washer (5)	8U-58	57	Throttle Disc	ML50K-102
21	Pendent Piston	ML50K-A246	● 58	Throttle Disc Seal (4)	ML50K-5
● 22	Pendent Piston Seal (2)	ML50K-248	● 59	Seal Expander (4)	410-283
23	Pendent Piston Rod	ML50K-A655	60	Valve Plate	ML50K-549
● 24	Piston Rod Seal	R0BR1C-283	61	Brake Tube	ML50K-401
25	Piston Drive Pin	ML50K-256	● 62	Brake Tube Seal (2)	ML50K-21
26	Piston Spring (2)	ML50K-250	● 63	Brake Tube Housing Seal	PS3-67
27	Piston Spring Retainer (2)	ML50K-249			
28	Piston Cylinder Cap (2)	ML50K-238			
● 29	Cylinder Cap Seal (2)	HRA20A-117			
30	Cylinder Cap Screw (8)	CE110-354			
31	Muffler	ML50K-175			

* Not illustrated.

● To keep downtime to a minimum, it is desirable to have on hand certain repair parts. We recommend that you stock one (pair or set) of each part indicated by a bullet (●) for every four tools in service.

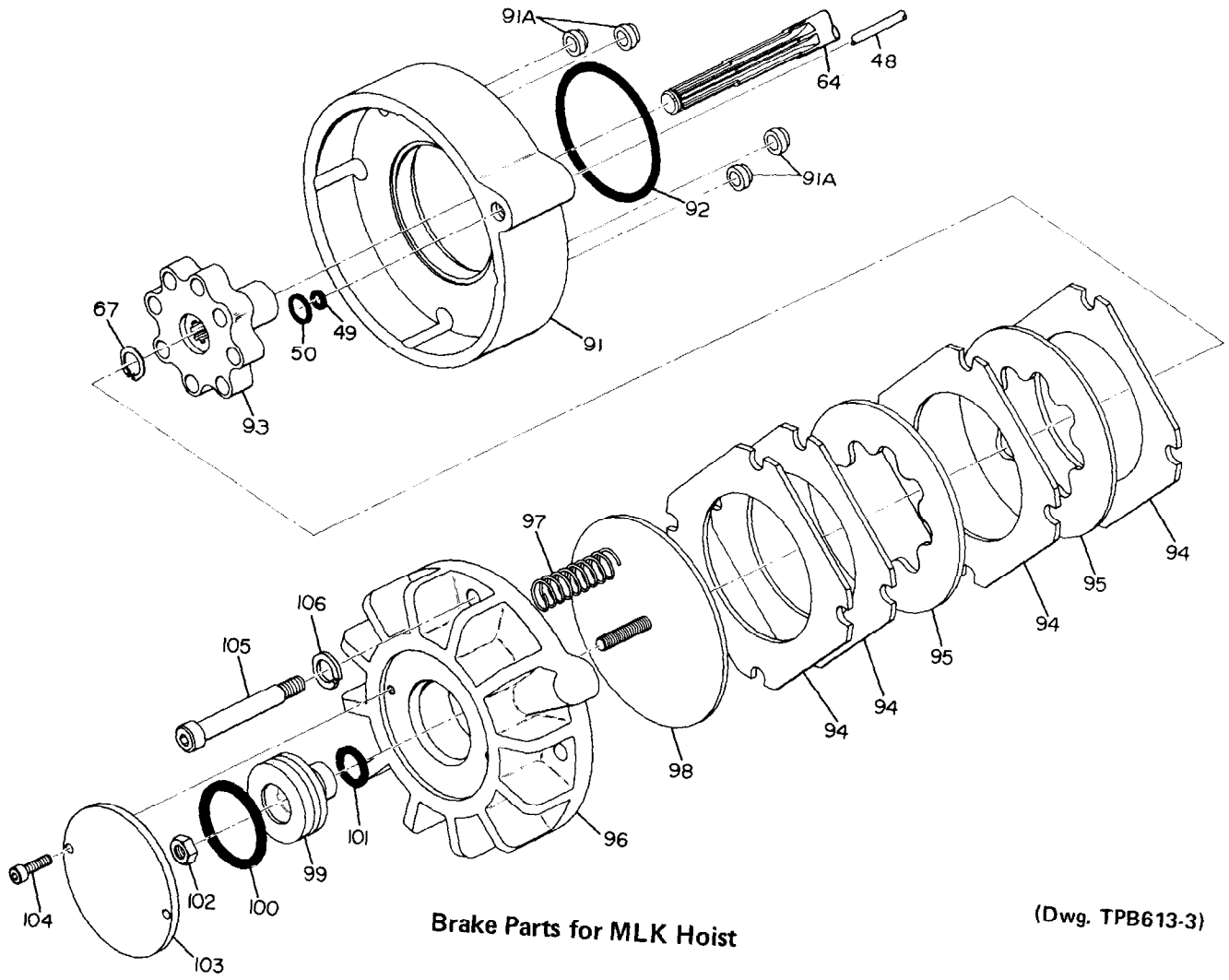

Brake Parts for MLK Hoist

(Dwg. TPB613-3)

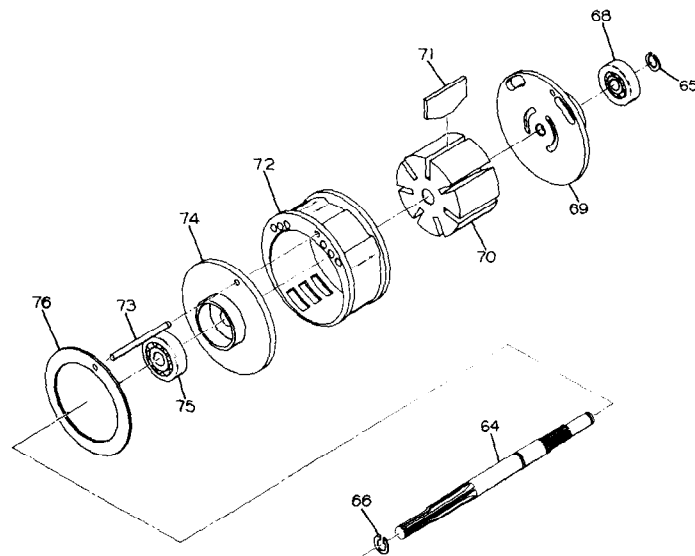

Motor Parts for MLK Hoist

(Dwg. TPB702)

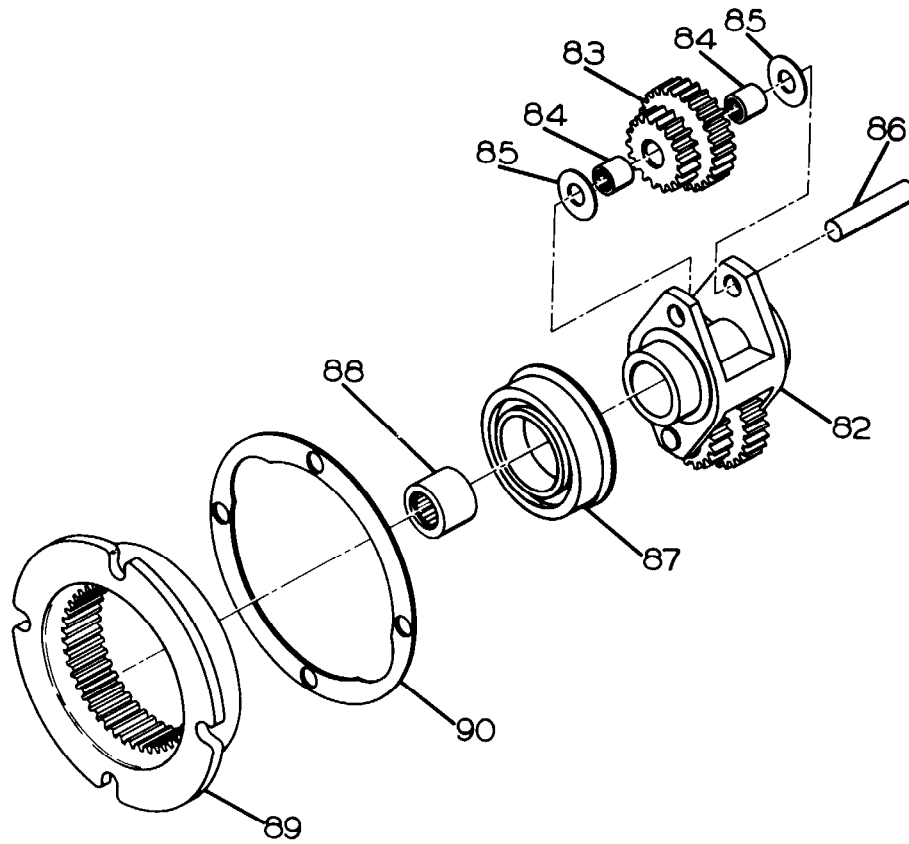

(Dwg. TPC396-1)

Gearing for MLK Hoist

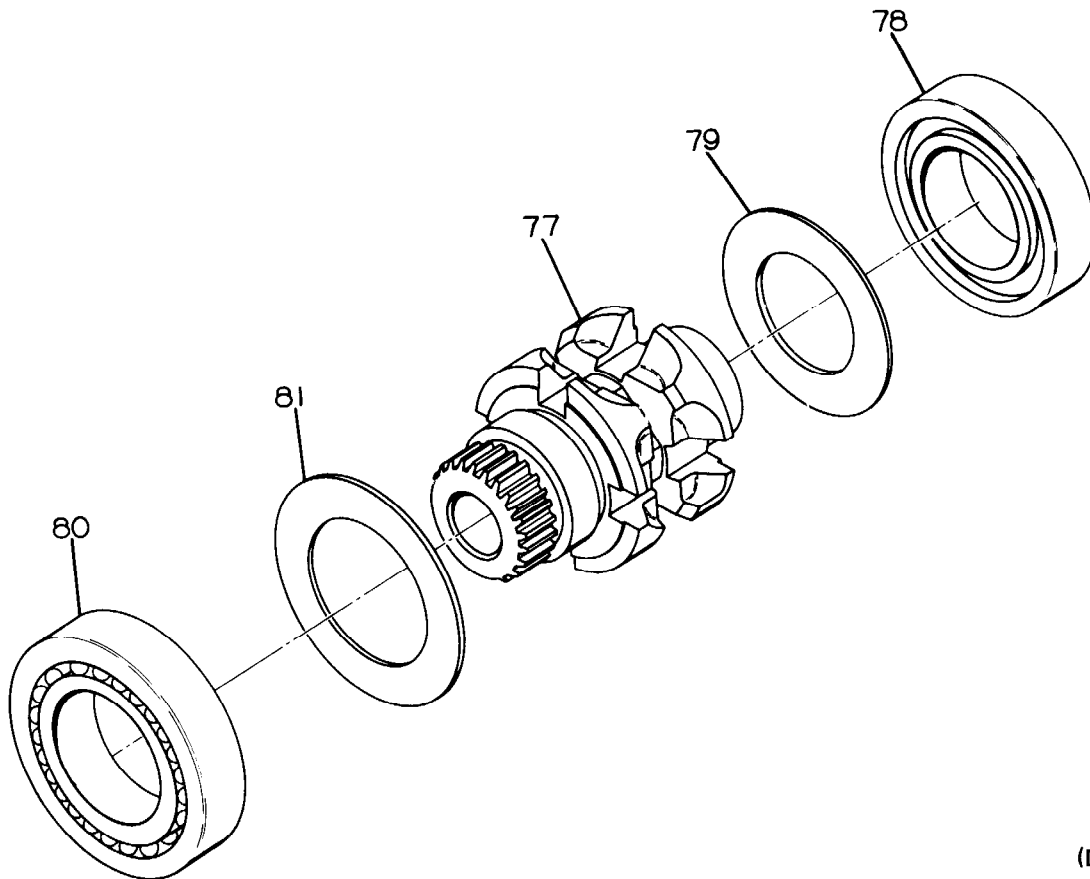

(Dwg. TPC397-1)

Sprocket Assembly for MLK Hoist

PART NUMBER FOR ORDERING

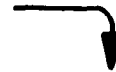

64	Motor Shaft	ML50K-316
● 65	Motor Shaft Rear Retaining Ring	MLK-120
● 66	Motor Shaft Front Retaining Ring	MLK-119
67	Brake Driver Retainer	ML50K-729
● 68	Rear End Plate Bearing	R2-24
69	Rear End Plate	ML50K-12
70	Rotor	MR-53
● 71	Vane Packet (set of 7 Vanes)	MR-42-7
72	Cylinder	MR-3
73	Cylinder Dowel	R3H-434
74	Front End Plate	MR-11
● 75	Front End Plate Bearing	TB-394
76	Motor Retaining Washer	MR-207
77	Chain Wheel	ML-740B
● 78	Chain Wheel Plain End Bearing	MR-593
79	Chain Wheel Plain End Washer	MR-974
● 80	Chain Wheel Splined End Bearing	MR-988
81	Chain Wheel Splined End Washer	MR-975
	Gear Frame Assembly	
	for ML25K	ML25K-A8
	for ML50K and ML100K	ML50K-A8
82	Planet Gear Frame	
	for ML25K	ML25K-8
	for ML50K and ML100K	ML50K-8
83	Planet Gear Assembly (2)	
	for ML25K	MR5-A10
	for ML50K and ML100K	MR-A10
84	Planet Gear Bearing (2 for each Gear)	ML50K-654
85	Planet Gear Thrust Washer (4)	ML50K-361
86	Planet Gear Shaft (2)	MR-191
87	Gear Frame Bearing	ML50K-97
● 88	Brake Driver Bearing	ML50K-318
89	Ring Gear	ML50K-406
● 90	Ring Gear Gasket	ML50K-31
91	Brake Housing	ML50K-346
91A	Brake Housing Bolt Seal (4)	ML50K-271
● 92	Brake Housing Bearing Seal	HRA20A-990
93	Brake Driver	ML50K-842
94	Brake Plate (4)	ML50K-834
● 95	Brake Disc (2)	ML50K-855
	Brake Spring and Piston Housing Assembly	ML50K-A395
96	Spring and Piston Housing	ML50K-395
97	Spring (3)	ML50K-832
98	Pressure Plate	ML50K-A338
99	Piston	ML50K-A809
● 100	Piston Large Seal	R2C-103
● 101	Piston Small Seal	R00BR-210
102	Piston Nut	ML50K-394
103	Plate	ML50K-981
104	Plate Screw (2)	CE110-354
105	Shoulder Bolt (4)	ML50K-7
106	Lock Washer (4)	D02-321
*	Chain Anchor Bolt	20BM-744

* Not illustrated.

● To keep downtime to a minimum, it is desirable to have on hand certain repair parts. We recommend that you stock one (pair or set) of each part indicated by a bullet (●) for every four tools in service.



*	Lock Washer	L01-67
*	Washer	B12-265
*	Chain Anchor Bolt Spacer	ML50K-145
111	Chain	
	for ML25K and ML50K with 10' (3.05 m) maximum lift	CE110-745
	for ML100K with 10' (3.05 m) maximum lift	CE120-745
▲	lift as specified	ML-745
112	Stop Ring Assembly (for ML25K and ML50K).	MR-A259
113	Stop Ring Pin	34U-215A
114	Stop Ring Plug	502-95
	New Style Bottom Hook Assembly (for ML25K and ML50K).	MLK-A463
116	Hook Block (2).	MLK-463
117	Hook	CE110-KS304
● 118	Hook Latch Kit.	CE110-S123
● 119	Hook Bearing	R4810-105
● 120	Thrust Race (2).	CE110-596
121	Hook Block Bolt (2)	MLK-461
	Bottom Hook and Block Assembly (for ML100K)	ML100K-A378
126	Sheave Block Assembly (includes bearing) (2).	CE120-B378
127	Sheave Block Screw (3)	CE120-312
128	Sheave Block Insert (3).	CE120-38
129	Pocket Wheel	CE120-380
130	Thrust Spacer (2)	CE120-80
131	Bottom Hook	HRA20A-S377
● 132	Hook Latch Kit.	D01-S123
● 133	Hook Bearing	CE110-295
● 134	Thrust Race (2).	CE120-596
	Top Hook and Yoke Assembly	
	for ML25K and ML50K	MR10-AS590A
	for ML100K.	ML100K-A590
135	Top Hook Yoke	
	for ML25K and ML50K	MR10-590A
	for ML100K.	ML20-590A
136	Top Hook	
	for ML25K and ML50K	CE110-KS304
	for ML100K.	HRA20A-S377
● 137	Hook Latch Kit	
	for ML25K and ML50K	CE110-S123
	for ML100K.	D01-S123
● 138	Hook Retaining Ring	
	for ML25K and ML50K	MR10-375
	for ML100K.	HRA20A-375
● 139	Hook Bearing	
	for ML25K and ML50K	R4810-105
	for ML100K.	CE110-295
● 140	Thrust Race (2)	
	for ML25K and ML50K	CE110-596
	for ML100K.	CE120-596
141	Top Hook Yoke Pin (2).	MR-964

* Not illustrated.

▲ When ordering Chain specify both the model number of the Hoist and the desired maximum lift.

● To keep downtime to a minimum, it is desirable to have on hand certain repair parts. We recommend that you stock one (pair or set) of each part indicated by a bullet (●) for every four tools in service.

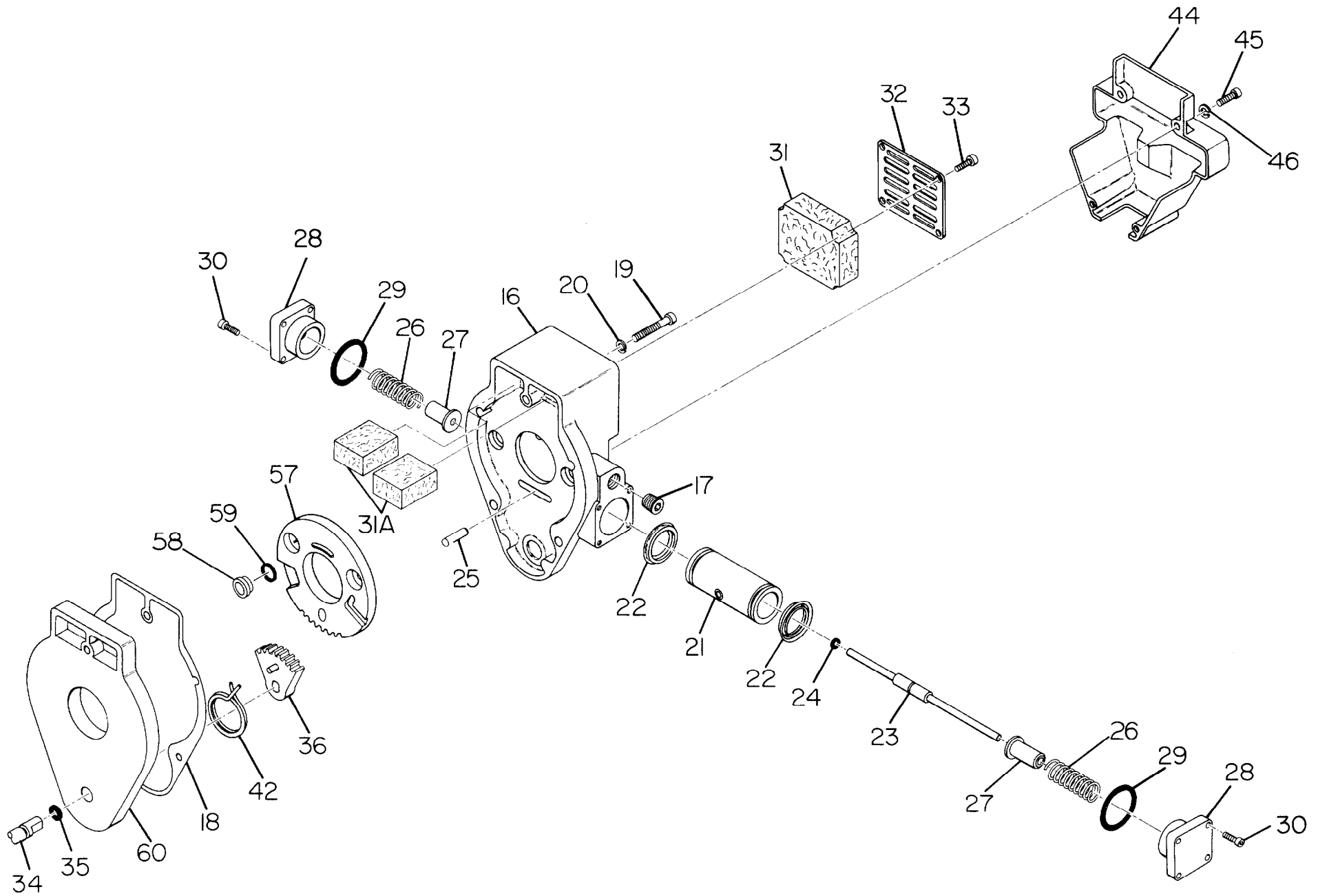

Valve Chest for MLK Hoist

(Dwg. TPA712-2)

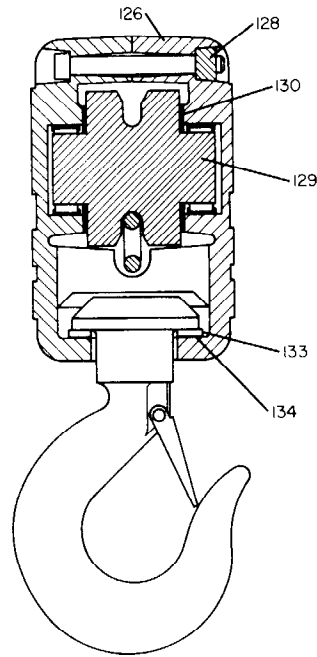
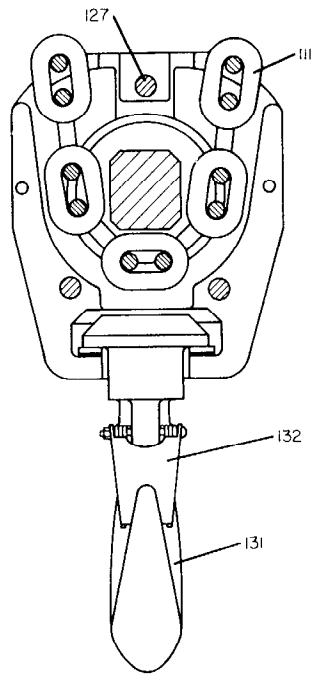

(Dwg. TPC401)

Bottom Hook and Block Assembly for ML100K Hoist

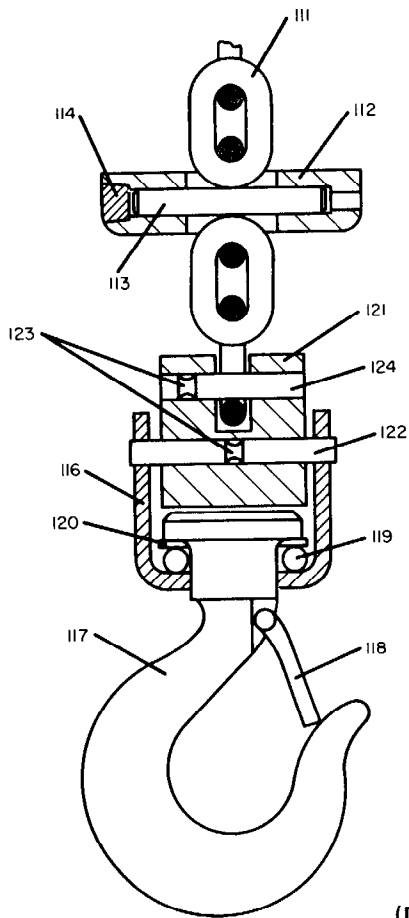

(Dwg. TPD785)

New Style Bottom Hook for ML25K and ML50K Hoists
(Refer to page 30 for Old Style Bottom Hook)

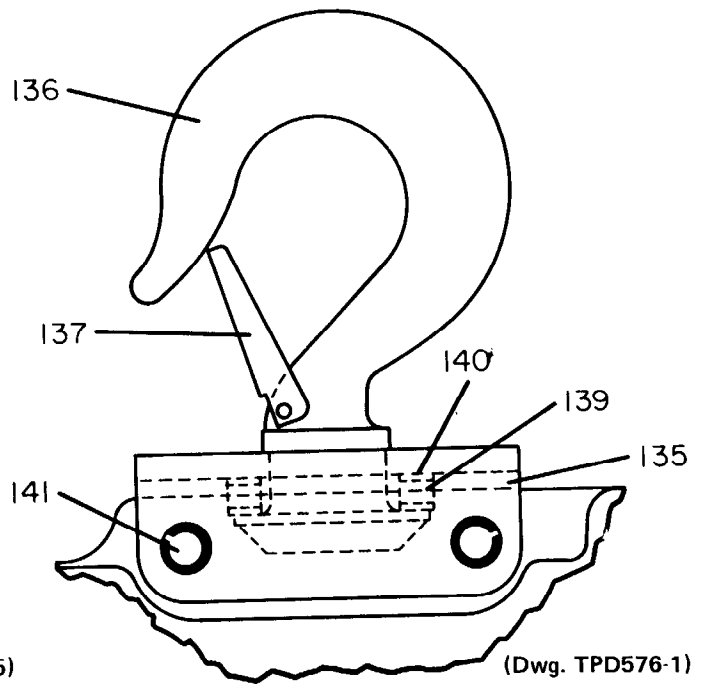

(Dwg. TPD576-1)

Top Hook and Yoke for MLK Hoists

OLD STYLE PENDENT HANDLE ASSEMBLY

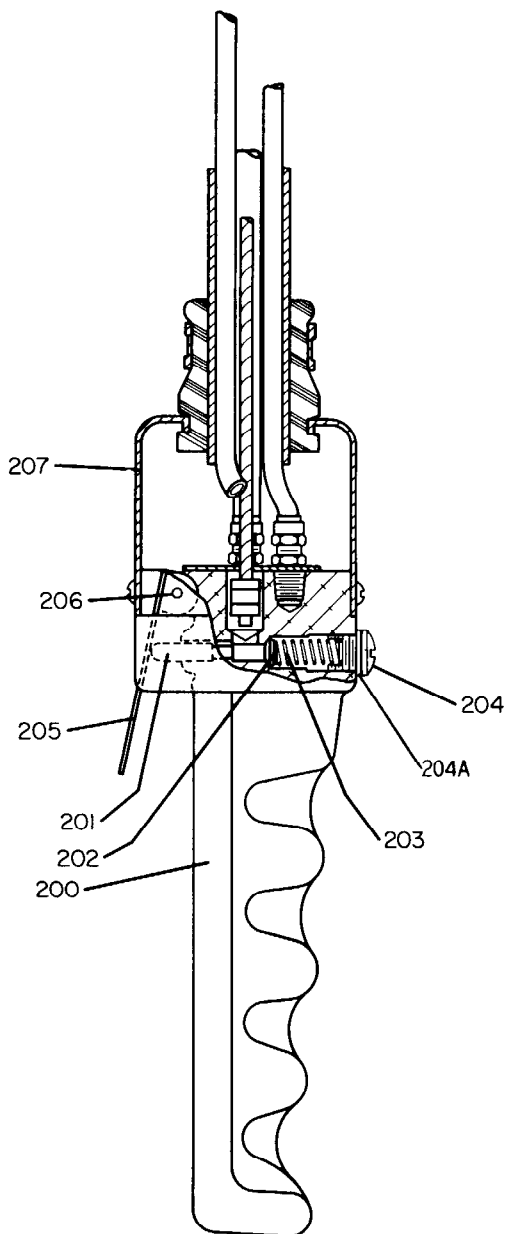

(Dwg. TPC394-1)

PART NUMBER FOR ORDERING

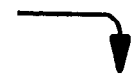

	Pendent Handle Assembly	} No longer available	
200	Pendent Handle		
201	Pendent Throttle Valve (2)		ML50K-A264
● 202	Throttle Valve Face		R000BR1C-283
● 203	Pendent Throttle Spring (2)		R0H-51
204	Pendent Throttle Valve Cap (2)		R000A2-266
204A	Valve Cap Gasket (2)		AB025-239
205	Pendent Throttle Lever (2)		HRA20A-273
206	Throttle Lever Pin		508-98
207	Handle Cover		ML50K-270
*	Handle Cover Screw (4)		R2FA-662

* Not illustrated.

● To keep downtime to a minimum, it is desirable to have on hand certain repair parts. We recommend that you stock one (pair or set) of each part indicated by a bullet (●) for every four tools in service.

NEW STYLE PENDENT HANDLE ASSEMBLY

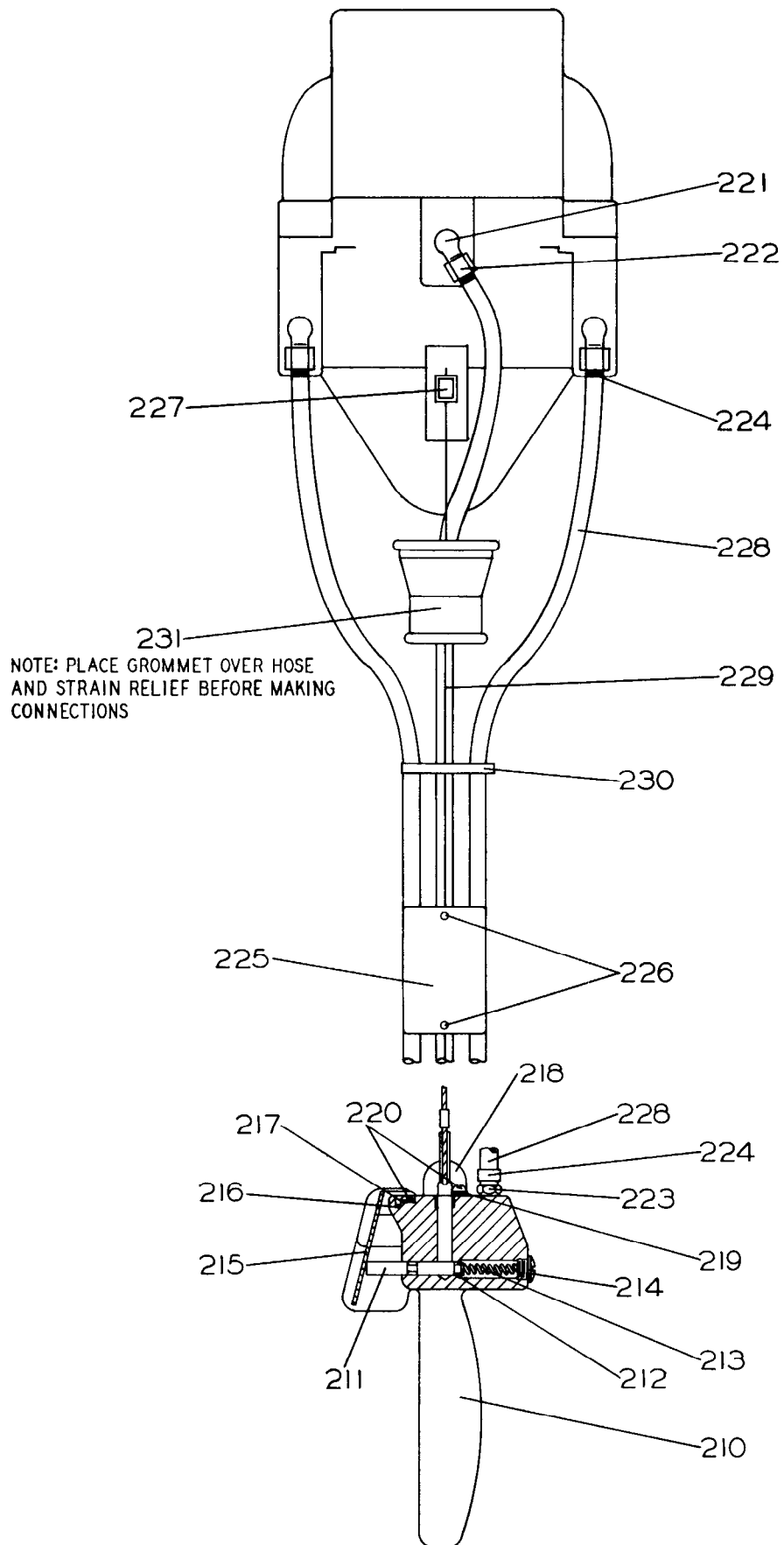

(Dwg. TPB701-1)

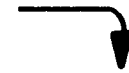

	Pendent and Hose Bundle	
	for 5 ft length.	MLK-A169-10
	for length as specified.	MLK-AL169
	Pendent Handle Assembly.	MLK-A269
210	Pendent Handle.	MLK-269
● 211	Pendent Throttle Valve (2)	MLK-K264
● 212	Throttle Valve Face	R000BR1C-283
213	Pendent Throttle Spring (2).	MLK-51
214	Pendent Throttle Valve Cap (2)	R000A2-266
215	Pendent Throttle Lever (2)	MLK-273
216	Throttle Lever Pin	DLC-120
217	Pin Lock Washer (2).	D02-138
218	Strain Relief Support	MLK-450
219	Relief Support Lock Washer (2).	H54U-352
220	Handle Screw (4).	MF-31
221	1/8-27 NPT to 7/16-20 Tube Male Brass Elbow (3)	MLK-161
	Hose and Strain Relief Bundle Assembly	
	for 5 ft Pendent	ML50K-AH3A-5
	for length as specified.	ML50K-AL3A
222	Hose Assembly (3)	
	for 5 ft Pendent	MLK-H3A-5
	for length as specified.	MLK-LH3A
223	Hose Clamp (6).	CA110-476A
224	7/16 x 3/16 Barbed Female Swivel Fitting (3).	MLK-162
225	1/8 NPT x 3/16 Barbed Straight Fitting (3)	MLK-170
226	Strain Relief Assembly	
	for 5 ft pendent	ML50K-WR3A-5
	for length as specified.	ML50K-LWR3A
227	Clamping Sleeve	MLK-521
228	Cable Thimble	MLK-602
229	Stop Sleeve	ML50K-520
230	Warning Plate	CA110-598
231	Warning Plate Fastener (2)	CE110-4
232	Hose Tie (3 for 5 ft Pendent; 2 additional for each additional 5 ft of Pendent)	HRE20A-283
233	Grommet.	ML50K-236
234	Bushing	HRA20A-82

- To keep downtime to a minimum, it is desirable to have on hand certain repair parts. We recommend that you stock one (pair or set) of each part indicated by a bullet (●) for every four tools in service.

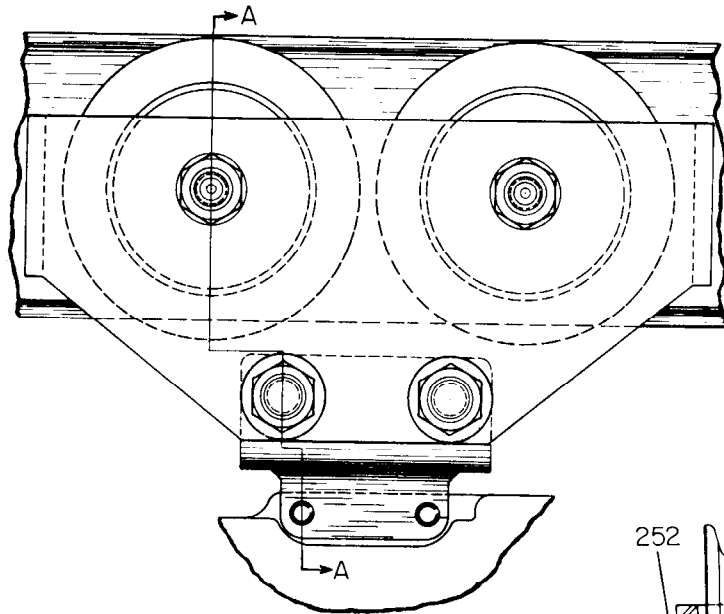

Side View of Rigid Trolley

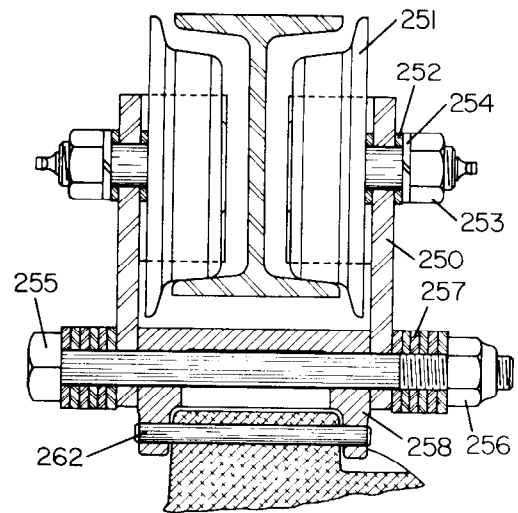

Sec. A-A

**End View of Rigid Trolley
for ML25K and ML50K**

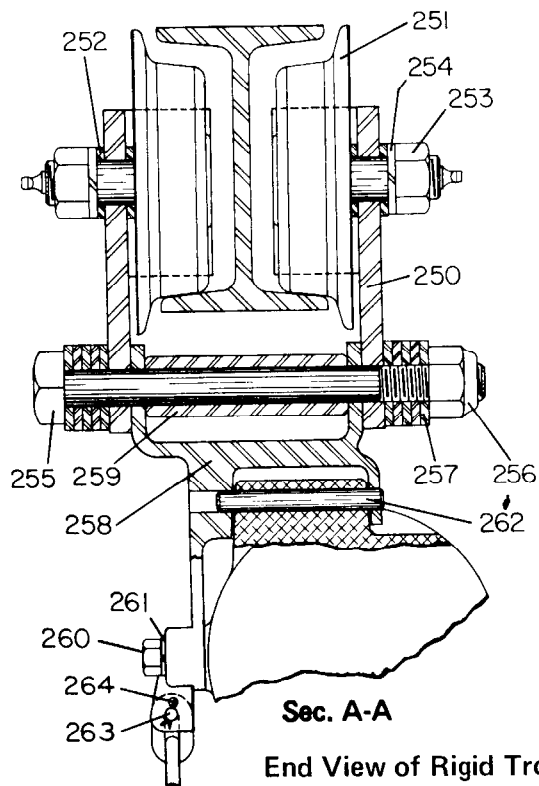

Sec. A-A

**End View of Rigid Trolley
for ML100K**

(Dwg. TPA825-1)

Trolley Parts for MLK Hoists

RIGID TROLLEY PARTS

PART NUMBER FOR ORDERING



	Rigid Trolley Kit	
	for operation on I-beam having flanges 2.66" (68 mm) to 5.00" (127 mm) wide for ML25K and ML50K (3-1/8" dia. wheels)	MLK-K430
	for operation on I-beam having flanges 3.00" (76 mm) to 5.00" (127 mm) wide for all Models (4" dia. wheels)	CE120-K430
	for operation on Flat-Tread Monorail for all Models (4" dia. wheels)	CE120-K430T
250	Trolley Bracket (2)	
	for MLK-K430	MLK-430
	for CE120-K430 and CE120-K430T	CE120-430
251	Trolley Wheel (4)	
	for MLK-K430	MR10-691
	for CE120-K430	MR20-691
	for CE120-K430T	MR20-691T
252	Trolley Wheel Spacer (8)	21-748
253	Trolley Wheel Shaft Nut (4)	DU-562
254	Trolley Wheel Shaft Lock Washer (4)	D01-692
255	Trolley Bracket Bolt (2)	D01-694-8
256	Trolley Bolt Nut (2)	D01-341A
257	Trolley Bracket Spacer (28) (as required)	D01-442-1/6
258	Top Lug	
	for ML25K and ML50K	MR10-425
	for ML100K	ML20-425
259	Top Lug Spacer (for ML100K) (2)	MR20-446
260	Top Lug Screw (for ML100K) (2)	D10-312A
261	Lock Washer (for ML100K) (2)	D02-321
262	Top Lug Pin (2)	MR-964
263	Link Chain Anchor Pin (for ML100K)	ML20-962A
264	Link Chain Anchor Pin Cotter (2) (for ML100K)	D02-524

HOOK-ON TROLLEY PARTS

PART NUMBER FOR ORDERING

Trolley Assembly	
for operation on 4" to 12" I-Beam having flanges 2.66" (68 mm) to 5.00" (127 mm) wide	
for ML25K and ML50K	MR10-7927
for operation on 5" to 12" I-Beam having flanges 3.00" (76 mm) to 5.00" (127 mm) wide	
for ML100K.	MR20-7928
for operation on Flat Tread Monorail	
for ML25K and ML50K	MR10-7927T
for ML100K.	MR20-7928T
Trolley Wheel (4)	
for Hook-On Trolley No. MR10-7927	MR10-691
for Hook-On Trolley No. MR20-7928	MR20-691
for Hook-On Trolley No. MR10-7927T	MR10-691T
for Hook-On Trolley No. MR20-7928T	MR20-691T
Semi-Rigid Trolley Adapter	
for ML25K and ML50K	MR10-852
for ML100K.	ML20-852

INSTALLATION INSTRUCTIONS FOR FABRIC CHAIN CONTAINER KITS ML50K-K479-17 AND ML50K-K749-45

WARNING: DISCONNECT THE HOIST FROM THE AIR SUPPLY BEFORE INSTALLING A CHAIN CONTAINER KIT.

Refer to illustrations on Page 28 and install a Fabric Chain Container as follows:

1. Insert a Container Bolt (270) through the boss on the Hoist housing and into the Brackets (266 and 267). Retain the Container with the Container Bolt Nuts (271). **Note:** If the Container is to be allowed to swing outward, tighten the Nuts to within one turn of being fully tight. This will allow the Container to swing away from a load.
2. Apply the Balance Chain (272) to the Container and Hoist using S-Hooks (273). Adjust the length of the Chain to prevent the load chain from rubbing on the Container.

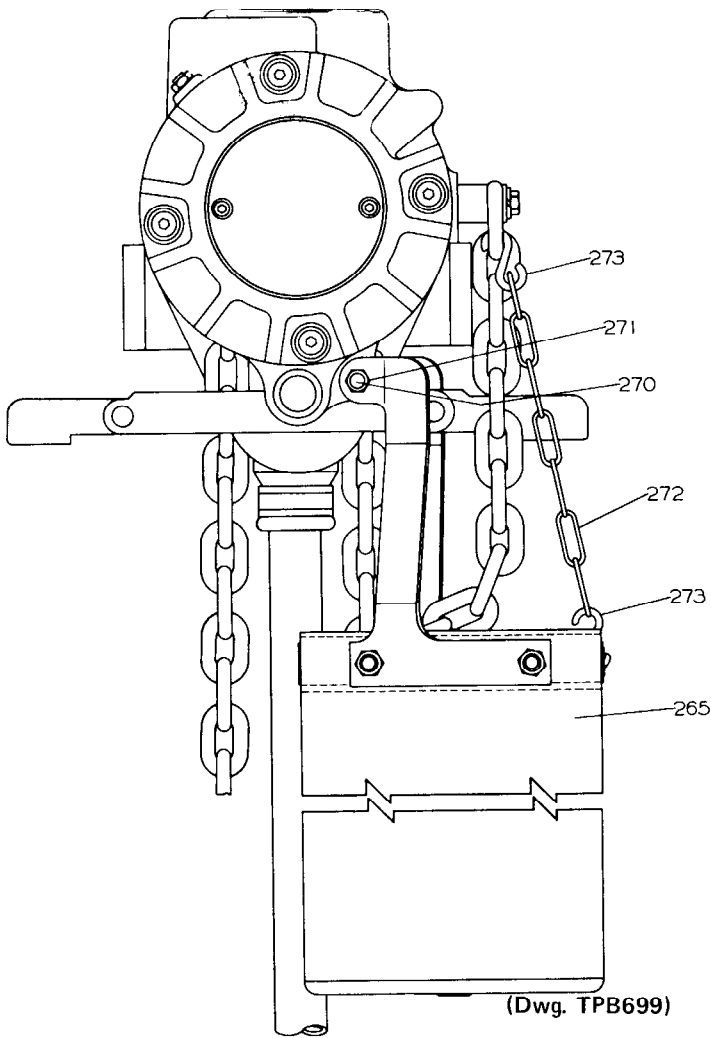

Chain Container for MLK Hoist

(Dwg. TPB699)

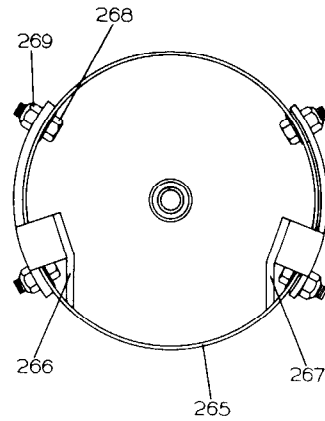

Top View of Chain Container for MLK Hoist

(Dwg. TPD717)

PART NUMBER FOR ORDERING

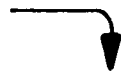

265	Fabric Chain Container for ML50K-K749-17 for ML50K-K749-45	ML50K-749-17 ML50K-749-45
266	Left Bracket	ML50K-748
267	Right Bracket	ML50K-747
268	Bracket Bolt (4)	R2N-103
269	Bracket Bolt Nut (4)	ML50K-394
270	Chain Container Bolt (2)	M0V010AA-634
271	Chain Container Bolt Nut (2)	ML50K-394
272	Balance Chain	CA110-240-1/2
273	S-Hook	D02-421

KITS AND ACCESSORIES

Fabric Chain Container: Includes Chain Container, Brackets and all hardware necessary for installation on a Hoist.

No. ML50K-K749-17 (03551066) for use on an ML25K or ML50K Hoist with up to a 17 ft lift and on an ML100K Hoist with up to a 9 ft lift.

No. ML50K-K749-45 (03551074) for use on an ML25K or ML50K Hoist with up to a 45 ft lift and on an ML100K Hoist with up to a 23 ft lift.

Link Chain Metal Containers: One (1) No. FMD2-68 (03109642) Chain Container Bolt and one (1) No. T11-58 (03141538) Lock Washer must be ordered with each Chain Container.

No. ML10-749 (03195336) for use on an ML25K or ML50K Hoist with up to 13 ft lift and on an ML100K Hoist with up to 6-1/2 ft lift.

No. ML20-749A (03195369) for use on an ML25K or ML50K Hoist with up to 26 ft lift and on an ML100K Hoist with up to 13 ft lift.

No. ML20-749-20 (03195385) for use on an ML25K or ML50K Hoist with up to 40 ft lift and on an ML100K Hoist with up to 40 ft lift.

Conversion Kits: Include all components necessary to convert a pull chain throttle Hoist to pendent control operation.

No. ML50K-K930-10 (03551140) for use on any MLK Hoist with 10 ft lift (5 ft pendent length).

No. ML50K-K930 (03551207) for use on any MLK Hoist with other than 10 ft lift. Length of pendent must be specified when ordering. Pendent bundle length is normally 5 ft shorter than lift.

Trolley Kits

No. CE120-K430 (03510435) Plain Trolley Kit - Includes all Trolley parts for suspending a Hoist equipped with lug mounting from an I-beam having 3.00" to 5.00" (76 mm to 127 mm) wide flange 4" (102 mm) diameter wheels.

No. CE120-K430T (03510443) Plain Trolley Kit - Includes all Trolley parts for suspending a Hoist equipped with lug mounting from a flat tread monorail having 2.66" to 5.00" (68 mm to 127 mm) wide flange 4" (102 mm) diameter wheels.

No. MLK-K430 (03611019) Plain Trolley Kit for use with ML25K and ML50K Hoist. Includes all Trolley parts for suspending a Hoist with lug mounting from an I-beam having 2.66" to 5.00" (68 mm to 127 mm) wide flange 3-1/8" (79 mm) diameter wheels.

Two and Three-Motor Pendants:

No. MLK-AL122 (03622487) - Two-motor pendent and hose assembly (Specify length of hose required).

No. MLK-AL132 (03622495) - Three-motor pendent and hose assembly (Specify length of hose required).

Cross Mount:

No. ML500K-444 (03613023) for use on ML25K or ML50K.

No. ML1000K-444 (03613031) for use on ML100K.

OLD STYLE BOTTOM HOOK FOR ML25K AND ML50K

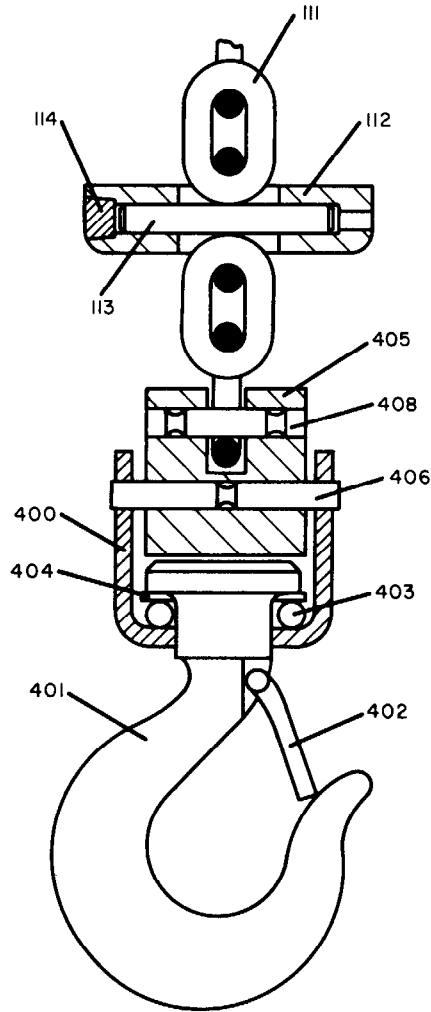

(Dwg. TPD577-1)

PART NUMBER FOR ORDERING



400	Hook Block (for ML25K and ML50K)	CE110-463
401	Hook	CE110-KS304
402	Hook Latch Kit.	CE110-S123
403	Hook Bearing.	MR10-379
404	Thrust Race.	CE120-596
405	Link Chain Connector	ML10-461
406	Connector Swivel Pin	MR10-462A
*	Set Screw (2).	R2J-561
408	Link Chain Pin.	ML10-603

* Not illustrated.



INGERSOLL-RAND

Atlanta, Ga.
111 Ingersoll-Rand Drive
Chamblee, Georgia 30341

Chicago, Ill.
886 Industrial Drive
Einhurst, Illinois 60126

Baton Rouge, La. 70816
4252 Rhoda Drive

Dallas, Texas 75247
8901 Directors Row

Boston, Mass.
2 Kunholm Dr.
Mottiston, Mass. 01746

Denver, Colo. 80207
5805 E. 39th Ave.

Charlotte, N. C. 28208
4840 Wilmont Rd.

Detroit, Mich.
22122 Telegraph Road
Southfield, Mich. 48075

Chattanooga, Tenn. 37408
1936 Central Ave.

Houston, Texas 77001
6800 Sands Point, P.O. 1455

Los Angeles, Calif. 90022
5533 East Olympic Blvd.

Milwaukee, Wis.
N84 W13540 Leon Rd.
Menomonie Falls, Wis. 53051

Minneapolis, Minn. 55404
Corner Franklin & Cedar

Power Tool Division
28 Kennedy Blvd.
East Brunswick, N. J. 08816

Newark, N. J.
28 Kennedy Blvd.
East Brunswick, N. J. 08816

New Orleans, La. 70005
939 Lake Ave. Metairie

Norfolk, Va.
1431C Air Roll Ave.
Virginia Beach, Va. 23455

Philadelphia, Pa.
651 Park Ave.
King of Prussia, Pa. 19406

Pittsburgh, Pa. 15220
6 Parkway Ctr.

Portland, Oregon 97214
240 S. E. Clay St.

Salt Lake City, Utah 84115
3007 South West Temple
Suite G

San Francisco, Calif.
14299 Wicks Blvd.
San Leandro, Calif. 94577

Seattle, Wash. 98188
345 Andover Park East

Shreveport, La. 71106
454 W. 61st St.

Syracuse, N. Y. 13208
505 Factory Ave.

St. Louis, Mo. 63132
1515 Page Industrial Blvd.

Washington, D. C. 20006
1666 K. St., N. W.

Regional Sales Office and All-Star Servicenter.

All-Star Servicenter only.

CANADA

Calgary, Alberta, T2R 0E1
611 11th Ave., S. W.

Shawbrooke, Quebec
375 Courcellette St., J1H 3X4
Box 1500, J1H 5M3

Ingersoll-Rand Canada Inc
Montreal, Quebec, H3B 1S6
630 Dorchester Blvd. West

Toronto
Don Mills, Ontario M3B 2V1
255 Leamliff Road

Vancouver
British Columbia, V6A 2W7
1695 Main St.

Montreal, Quebec
620 Cathcart St., H3B 1M2
P.O. Box 1148, H3B 3K9

Sudbury, Ontario, P3A 3T3
P.O. Box 2220

Winnipeg, Manitoba, R3H 0M6
1234 Border St.

All-Star Servicenter.

AUTONOMOUS COMPANIES

Argentina, Buenos Aires
Ingersoll-Rand Argentina
S.A.I.y C.
Casilla Correo 2412, Correo Central

Egypt, Cairo
Ingersoll-Rand North East Africa
P.O. Box 820
23A Ismail Mohamed St.
Zamalek

Ireland, Dublin
Ingersoll-Rand Company (Ireland) Ltd.
John F. Kennedy Drive
Bluebell

Peru, Lima
Ingersoll-Rand Co. of Peru, S.A.
Casilla 2261

Australia, South Melbourne
Ingersoll-Rand (Australia) Ltd.
P.O. Box 219
42 Moray Street, 3205 Victoria

England, London, SW1X, 7LU
Ingersoll-Rand Co., Ltd.
Bowater House, Knightsbridge

Italy, 20100 Milano
Ingersoll-Rand Italiana, S.p.A.
Strada Provinciale Cassanese
Caselle Postale 1232
Vignate, Italy

Philippines, Makati, Rizal 3117
Ingersoll-Rand Philippines, Inc.
P.O. Box 445 MCC

Austria A 1120, Vienna
Ingersoll-Rand Ges M.B.H.
Schoenbrunnerstrasse 213-215/2/5

France, 78 190 Trappes Yvelines
Compagnie Ingersoll-Rand
Avenue Albert Einstein
Zone Industrielle

Japan, 106 Tokyo
Ingersoll-Rand (Japan) Ltd.
Kowa Bldg. No. 17
2-7 Nishi-Azabu 1-Chome
Minato-Ku

Portugal, Lisbon 5
Ingersoll-Rand Lda.
Apartado 2933

Belgium, Diegem (Brussels)
Ingersoll-Rand Benelux S.A.
Kouterveldstraat 10-12, 1920 Diegem

Germany, 403 Ratingen
Ingersoll-Rand GmbH
Robt. Zapp Str. 7
Postfach 1380

Kenya, Nairobi
Ingersoll-Rand Mid Africa
P.O. Box 14240

Puerto Rico, San Juan 00936
Ingersoll-Rand de Puerto Rico Inc.
G.P.O. Box 1222

Brazil, Sao Bernardo
Ingersoll-Rand S.A. Ind. e Com.
Caixa Postal 911

Greece, Athens 610
Ingersoll-Rand Central Middle East
17th Floor Athens Tower
Mesogion 2-4

Malaysia, Petaling Jaya
Ingersoll-Rand Malaysia, Sdn. Bhd.
P.O. Box No. 125

Singapore 22
Ingersoll-Rand Southeast Asia (Pte.) Ltd.
G.P.O. Box 2062, Singapore 1

Chile, Santiago
Ingersoll-Rand Chile
Morande 341
Casilla 126-D

Hong Kong
Ingersoll-Rand Far East
19th Floor, Lap Heng House
50, Gloucester Road

Mexico, 10 D.F. Mexico
Ingersoll-Rand S.A. de C.V.
Apartado 41-666

South Africa, Alberton
Ingersoll-Rand Co. S.A. (Proprietary) Ltd.
P.O. Box 3720
Alrode, 1451

Colombia, Bogota
Mecquinarías Ingersoll-Rand
de Colombia, S.A.
Apartado Aero 7451

India, Bombay 400018
Ingersoll-Rand (India) Private Ltd.
44 Maulana Abdul Gaffar Rd.
P.O. Box 16564, Worli

Netherlands, Zoeterwoude
Ingersoll-Rand Benelux N.V.
P.O. Box 33, Zoeterwoude

Spain, Madrid
Cia. Ingersoll-Rand, S.A.
Apartado 518

Denmark, Albertslund DK2620
Ingersoll-Rand AB
Herstedvang 11

Norway, Oslo 1
Ingersoll-Rand AB
P.O. Box 143-Sentrum

Sweden, Bromma
Ingersoll-Rand A.B.
Fack
S-16125 Bromma 1

Venezuela, Caracas
Ingersoll-Rand de Venezuela S.A.
Apartado 70588, Los Ruices

Distributors in principal cities throughout the world. Contact the nearest Ingersoll-Rand office for the name and address of the distributor in your country or write to Ingersoll-Rand International, Woodcliff Lake, New Jersey.

AUTHORIZED I-R SALES AND SERVICE

INGERSOLL-RAND

9H0