

SERIES K4U, K4UL, K5U AND K5UL UTILITY® WINCHES

WARNING

These Winches are not to be used for lifting or lowering people

Always operate and maintain this Winch in accordance with American National Standards Institute Safety Code (ANSI B30.7) and any other applicable safety codes and regulations.

FOR TOP PERFORMANCE AND MAXIMUM DURABILITY OF PARTS, OPERATE THIS WINCH AT 90 psig (6.2 bar/620 kPa) AIR PRESSURE WITH 1-1/2" (38 mm) DIAMETER HOSE.

OPERATING PRACTICES

The two most important aspects of Winch operation are: (1) Allow only qualified people to operate a Winch and (2) Subject each Winch to a regular inspection and maintenance procedure.

A qualified operator must be physically competent. He must have no health condition which might affect his ability to react, and he must have good hearing, vision and depth perception. The qualified Winch operator must be carefully instructed in his duties and must understand the operation of the Winch, including a study of the manufacturer's literature. He must thoroughly understand proper methods of hitching loads. He should have a good attitude regarding safety and should refuse to operate under unsafe conditions.

Regular inspection procedures should be set up, rigidly adhered to and recorded by or under direction of a qualified person. On Winches in continuous service, inspection should be made at the beginning of each shift. The items to be checked include, but are not limited to:

- a. **LUBRICATION:** See lubrication instructions on Page 3.
- b. **BRAKES:** Visually check for proper adjustment.
Lift a capacity or near capacity load a few inches off the floor and check ability of braking system to stop and hold the load without excessive drift.
- c. **WIRE ROPE AND HOOKS:** Visually inspect the wire rope. Replace it **AT ONCE** if there is indication of fraying, or if it is crushed, cut or otherwise damaged. Follow cable manufacturer's recommended practice for proper use and inspection of wire rope.
Hooks should be checked for wear, increase in throat opening, and bending.
- d. **CONTROLS:** See that controls function properly and return to neutral when released.
- e. **GENERAL:** Check to see that mounting fastenings are secure, unworn and undamaged. Be alert for unusual visual or audible signs which could indicate a defect. Do not operate the Winch until the defect has been determined and corrected.
Periodically, depending on the severity of the service:
 - a. Inspect Brake and Locking Dog components for wear or damage.
 - b. Check all bolts or fasteners.
 - c. Inspect the Winch structure for damage.

Notice: The use of other than genuine Ingersoll-Rand replacement parts may result in decreased tool performance and increased maintenance, and may, at the Company's option, invalidate all warranties.

Refer All Communications to the Nearest
Ingersoll-Rand Office or Distributor.

© Ingersoll-Rand Company 1981

Printed in U.S.A.

INGERSOLL-RAND®
AIR HOISTS & WINCHES

**P
A
R
T
S

B
U
L
L
E
T
I
N**

OPERATING INSTRUCTIONS

1. Read the manufacturer's instructions before operating the Winch.
2. Never lift a load greater than the rated capacity of the Winch.
3. Never use the Winch rope as a sling.
4. Always stand clear of the load.
5. Never use the Winch for lifting or lowering people, and never stand on a suspended load.
6. Never carry loads over people.
7. Before each shift, check the Winch for wear or damage. Check brakes, locking dog, etc.
8. Periodically inspect the Winch thoroughly and replace worn or damaged parts.
9. Follow the lubrication instructions.
10. Do not disengage clutch with a load on the Winch. Be sure clutch is fully engaged before operating Winch.
11. Do not "side pull" or "yard".
12. Always rig the Winch properly and carefully.
13. Never operate a Winch with twisted, kinked or damaged wire rope.
14. Be sure cable winds properly on drum.
15. Ease the slack out of the wire rope and sling when starting a lift. Do not jerk the load.
16. Be certain there are no objects in the way of a load or hook when operating the Winch.
17. Be certain the air supply is shut off before performing maintenance work on the Winch.
18. Shut off air supply while Winch is unattended.
19. Properly secure the Winch before leaving it unattended.
20. Be certain the load is properly seated in the saddle of the hook. Do not tiplod the hook as this leads to spreading and eventual failure of the hook.
21. Do not allow unqualified personnel to operate a Winch.
22. Do not swing a suspended load.
23. Do not operate a Winch if you are not physically fit to do so.
24. Do not do anything you believe may be unsafe.
25. Do not use the Winch rope as a ground for welding. Do not attach a welding electrode to a Winch or sling chain.
26. Do not divert your attention from the load while operating a Winch.
27. Engage locking dog before leaving load suspended.
28. Do not engage locking dog while drum is in operation.
29. Do not leave a load suspended for any extended period—never unattended.
30. Never splice a sling chain by inserting a bolt between links.
31. Do not force a chain or hook into place by hammering. Do not insert the point of the hook into a chain link.
32. Do not expose the sling chain to freezing temperatures, and do not apply sudden loads to a cold chain.

LUBRICATION

Warning: Lubricate the motor before using the Winch. To avoid leakage during shipment, the oil was drained from the motor. A quantity of oil sufficient for one filling is contained in the can packed with the Winch. Before using the Winch, make sure the Drain Plugs (2) are screwed securely into place, then unscrew the Vent Cap (4) and pour the entire contents of the can into the opening in the top of the Motor Case (1).

Motor Lubrication

Check oil daily and maintain level with opening in the side of the Motor Case.

When the Winch is subjected to temperatures above freezing: After the Winch has been idle for several hours or overnight, loosen the Drain Plug (2) located at the bottom of the Motor Case (1) and allow the accumulated water to drain out. After draining the water, tighten the Plug in the bottom and remove the Plug (2) on the side of the Motor Case. Unscrew the Vent Cap (4) and pour a sufficient quantity of the recommended oil through this opening to bring the oil level, within the Motor Case, up to the side opening. Replace the Plug and Vent Cap.

When the Winch is subjected to freezing temperatures: Allow the Winch to remain idle long enough for the water content in the Motor Case (1) to separate from the oil, but not long enough for it to freeze. Drain the water and replenish the oil as above. Should this procedure be impractical, drain the entire contents of the Motor Case immediately after operation ceases and pour the oil back into the Motor Case before resuming operation. If not drained, a sufficient quantity of water will eventually accumulate so that the Oil Splasher (37), which is attached to the Crank (36) will freeze fast.

For temperatures 30° to 80° F (-1° C to 26° C), use Ingersoll-Rand Pneu-Lube® Medium Oil No. 50 or SAE 20 or 20W motor oil.

For temperatures below 30° F (-1° C), use SAE 10 or 10W motor oil.

For temperatures above 80° F (26° C), use SAE 30 motor oil.

Throttle Valve Lubrication

Weekly, insert a small quantity of Ingersoll-Rand Light Grease No. 28 or a good quality No. 2 cup grease into the Grease Fittings (14) located in the Valve Chest (10). Two or three strokes from the No. P25-228 Grease Gun is ample for each Fitting.

Gearing Lubrication

Every sixty to ninety days, remove the Grease Plug (108) from the Gear Case (84) and note if the visible portion of the gears is coated with grease. If the gears appear to lack lubrication, add about 1/2 pound (.23 kg) of the recommended grease. When reassembling a Winch, three pounds (1.4 kg) of grease are required.

Use Ingersoll-Rand Heavy Gear Grease No. 70. As a substitute, Ingersoll-Rand Light Grease No. 28 or a good quality No. 2 cup grease may be used.

For extremely low temperatures, Ingersoll-Rand Medium Gear Grease No. 75, low temperature grease or a heavy gear oil may be used. **Note:** Leakage will probably be experienced if heavy gear oil is used for normal temperatures.

Lubricate the Drum Gear occasionally by pushing a piece of hard stick or block grease 3/4" to 1" (19 mm to 25 mm) long through the hole above the Drum Shaft Long Set Screw (75).

An Air Line Lubricator is recommended for use with Utility Winch. It will improve the efficiency of the Winch and prolong the life of the motor.

HOSE AND HOSE CONNECTIONS

Use 1-1/2" (38 mm) hose with a suitable hose fitting for attaching it to the inlet. Use of smaller hose and fittings will reduce the efficiency of the Winch.

MOUNTING

Mount the Winch so that the axis of the Rope Drum (67) is horizontal. Operation of the Winch with the axis of the Drum more than 10° from horizontal will result in lubrication difficulties and the Wire Rope will tend to pile up on the low end of the Drum.

On all 4-cylinder Winches, the Motor Case (1) can be rotated on the Motor Mounting Bracket (66) to any one of eight different positions. When a Winch is shipped from the factory, the Motor Case is positioned for operation when the Winch is mounted upright on its base. Therefore, the Motor Case must be repositioned if the Winch is to be mounted with the Vent Cap (4) more than 25° off top vertical center. To change the position of the Motor Case:

1. Drain the oil.
2. Unscrew the eight Motor Case Screws (57).
3. Rotate the Motor Case to bring the Vent Cap as near top vertical center as possible.
4. Replace the Cap Screws.
5. Fill with oil.

On Model K5UL or K5U, the Motor Case (1) can be rotated on the Motor Mounting Bracket (66) to any one of five different positions. When a Winch is shipped from the factory, the Motor Case is positioned for operation when the Winch is mounted upright on its base. Therefore, the Motor Case must be repositioned if the Winch is to be mounted with the Drain Plug (2) more than 25° off bottom vertical center. To change the position of the Motor Case:

1. Drain the oil.
2. Unscrew the Motor Case Screws (57).
3. Rotate the Motor Case to bring the Drain Plug as near bottom vertical center as possible.
4. Replace the Cap Screws.
5. Fill with oil.

The Winch should not be operated with one of the Cylinders at bottom vertical center.

MAINTENANCE

Apply the Wire Rope to wind on the Rope Drum in the direction indicated by the instruction plate on the Winch.

Adjust the brake so that considerable pressure is required to push the Brake Handle (126) past center for locking. Make adjustment by removing the Brake Shoe Long Pin (131) and rotating the Brake Adjusting Screw (130).

Remove the Throttle Valve Spring (21), Poppet Throttle Valve (20) and Throttle Valve Ball (22) from the Valve Chest (10) before attempting to withdraw the Reverse Valve (24) from the Reverse Valve Bushing (13).

The following procedure is recommended when replacement of the Rotary Valve Bushing (12) or Reverse Valve Bushing (13) is necessary:

1. Unscrew the Valve Chest Screws (18) and remove the Valve Chest Cover (17).
2. Screw a No. HU-932 Jack Bolt into each tapped lug on the Valve Chest (10) until the Jack Bolts contact the Motor Case (1). Turn each Bolt a little at a time to jack the Chest with assembled parts from the Motor Case.
3. Unscrew the Throttle Valve Cap (23) and remove the Spring (21), Poppet Throttle Valve (20) and Ball (22) from the Valve Chest (10).
4. Withdraw the Rotary Valve (25) and Reverse Valve (24), and remove the Throttle Lever Spring (35).
5. Support the face of the Valve Chest (10) that contacts the Motor Case (1), and press out the old Bushings with an arbor **that will clear the Bushing Keys (11)**.
Caution: Failure to use an arbor that will clear the Bushing Keys, or pressing the Bushings in the opposite direction than instructed, will destroy the Keys.
6. Support the face of the Valve Chest (10) that contacts the Valve Chest Cover (17); align the keyslot in the new Reverse Valve Bushing with the Bushing Key (11), and press the Bushing into the Chest until the leading face of the Bushing is flush with the supported face of the Chest. Align the keyslot in the new Rotary Valve Bushing with the Bushing Key and press the Bushing into the Chest until the bushing shoulder is flush with the supported face of the Chest.
7. Insert the No. 23470 Throttle Valve Stem Reamer or a .505" (12.8 mm) hand reamer through the throttle valve chamber in the Valve Chest and ream the hole through the wall of the new Reverse Valve Bushing.
8. Check the fit of the Rotary Valve (25) in the new Rotary Valve Bushing. If the Valve is tighter than a good running fit in the Bushing, lap in the Valve, using a fine grain lapping compound whose abrasive agent will break up rapidly. Remove all trace of the compound after obtaining the desired fit.
9. Check the fit of the Reverse Valve (24) in the new Reverse Valve Bushing. If the fit is too tight, ream the Bushing 1.875" (47.625 mm).
Caution: The Reverse Valve is chromo-plated; do not lap.
10. Rotate the Reverse Valve in the Reverse Valve Bushing until the arrows on the two parts align, and install the Throttle Valve Ball, Poppet Throttle Valve, Spring and Cap.
11. Install the Throttle Lever Spring (35) and Throttle Control Arm (28).
12. Align the holes through the Valve Chest (10) with those in the face of the Motor Case (1) and squarely start the protruding end of the Rotary Valve Bushing into the Case. Place a hardwood block on the chest face and press or drive in the Bushing until the Valve Chest contacts the Motor Case.

The two sections of the Crank (36) are matched before final machining, and the web of each section is stamped with an identification mark as AA17, CC21, XX19, etc. Only sections bearing identical marking can be used together. If more than one Crank is disassembled at one time, be sure only matched parts are assembled together.

Slide the Crank Pin Sleeve (39), plain end first, onto the crank pin when assembling the Crank (36).

Install the Connecting Rod Rings (44) so that the internally beveled ends are toward the Connecting Rods (43) when assembling the Crank (36).

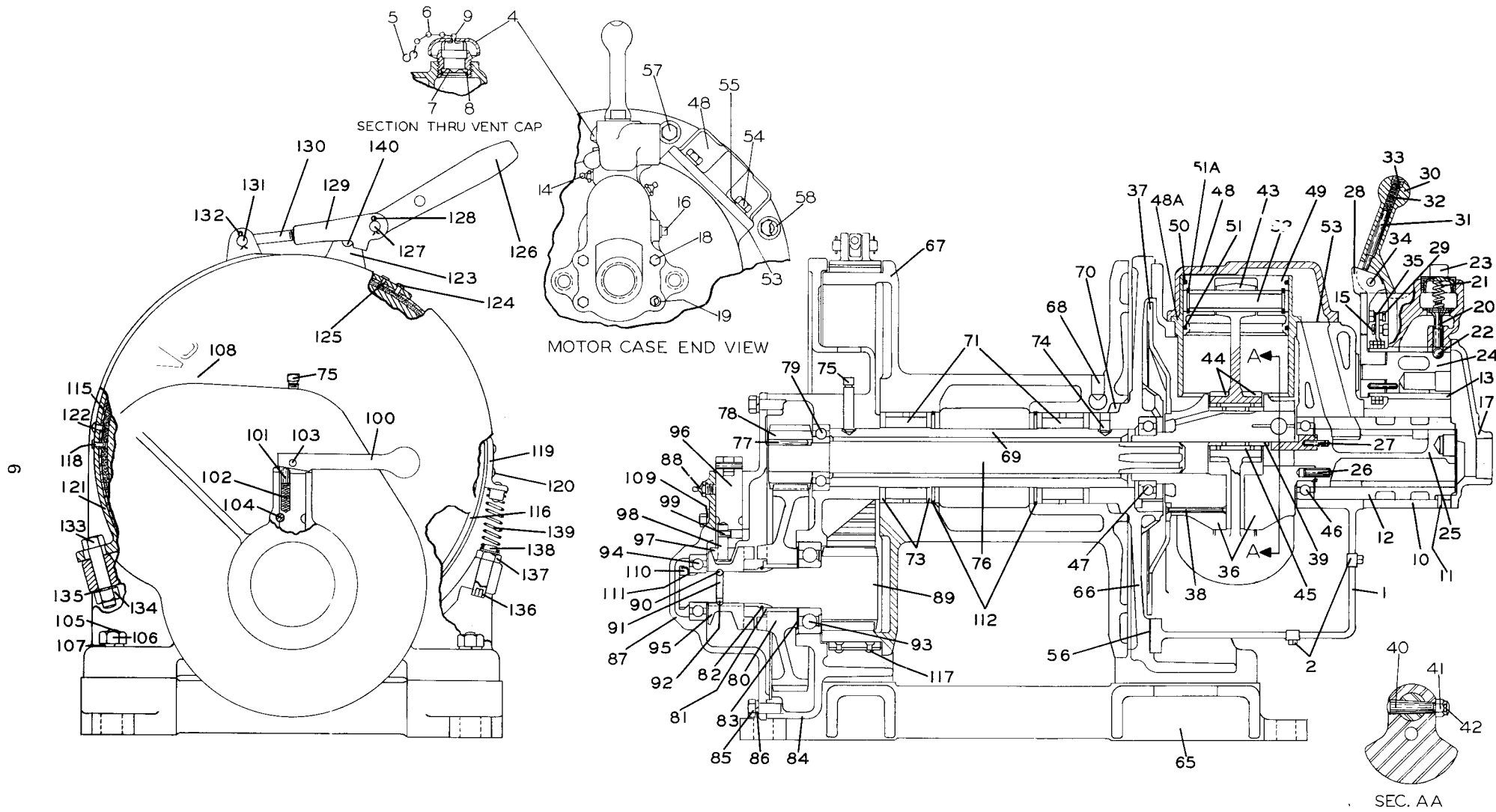

(Dwg. TPA254-2)

**Model K4U Utility Winch
(Typical of Model K5UL)**

MOTOR PARTS

PART NUMBER FOR ORDERING

PART NUMBER FOR ORDERING

	PART NUMBER FOR ORDERING		PART NUMBER FOR ORDERING
1	Motor Case for K4U or K4UL	KU-501	35 Throttle Lever Spring
	for K5U or K5UL	K5M-501	Crank Assembly
2	Drain Plug (2)	D02-402	for K4U or K4UL
*	Motor Eyebolt (2 for K5U or K5UL; 1 for others) . .	KU-888	for K5U or K5UL
*	1-1/4" Pipe Plug (for K5U or K5UL)	E5UD-947	36 Crank Bare (consists of 2 matched parts which are not sold separately)
4	Vent Cap	D02-303A	37 Oil Splasher
5	S-Hook	D02-421	38 Oil Splasher Long Rivet (2)
6	Vent Cap Chain	D02-891	* Oil Splasher Short Rivet (2)
7	Vent Cap Screen	D02-889	● 39 Crank Pin Sleeve
8	Vent Cap Screen Retainer	6CND-233-1/2	40 Crank Lock Pin
9	Vent Cap Cotter	D02-893	41 Crank Lock Pin Nut
† 10	Valve Chest		42 Crank Lock Pin Cotter
	for K4U or K4UL	KU-545A	● 43 Connecting Rod
	for K5U or K5UL	KK5UM-545	for K4U or K4UL (4)
† 11	Bushing Key (2)	HU-538	for K5U or K5UL (5)
† 12	Rotary Valve Bushing		44 Connecting Rod Ring (2)
	for K4U or K4UL	KU-525S	● 45 Connecting Rod Bushing
	for K5U or K5UL	K5M-525S	● 46 Crank Valve End Bearing
† 13	Reverse Valve Bushing	KU-945S	● 47 Crank Pin End Bearing
† 14	Grease Fitting (2)	23-188	Cylinder Assembly (5 for K5U or K5UL; 4 for others)
† 15	Throttle Lever Spring Stop Pin	D02-553	48 Cylinder Head
† 16	Brake Inlet Plug (2)	D02-402	48A Cylinder Sleeve
† 17	Valve Chest Cover	KU-546A	49 Piston Assembly (5 for K5U or K5UL; 4 for others)
† 18	Valve Chest Screw (4)	KU-548	Piston Ring (1 for each Piston)
† 19	1/2" Lock Washer (4)	D10-322	51 Oil Regulating Ring (1 for each Piston)
† 20	Poppet Throttle Valve	KU-940	51A Wrist Pin Retaining Ring (2 for each Piston)
● † 21	Poppet Throttle Valve Spring	HU-942	52 Piston Wrist Pin (5 for K5U or K5UL; 4 for others)
† 22	Poppet Throttle Valve Ball	D10-280	● 53 Cylinder Gasket (5 for K5U or K5UL; 4 for others)
† 23	Poppet Throttle Valve Cap	KU-943	54 Cylinder Cap Screw (4 for each Cylinder)
† 24	Reverse Valve		55 Cylinder Cap Screw Washer (4 for each Cylinder)
	for Winch with standard brake	KU-944	● 56 Motor Case Gasket
	for Winch with automatic brake	KU-744	for K4U or K4UL
† 25	Rotary Valve		for K5U or K5UL
	for overwinding Winch	KU-526A	KU-592
	for underwinding Winch	KU-526RA	K5M-592
● † 26	Large Valve Drive Pin	KU-527	57 Motor Case Screw (10 for K5U or K5UL; 8 for others)
● † 27	Small Valve Drive Pin (2)	HU-527	58 5/8" Lock Washer (10 for K5U or K5UL; 8 for others)
† 28	Throttle Control Arm	KU-555A	* Motor Nameplate
† 29	Throttle Lever Spring Stop Pin	D02-553	* Nameplate Screw (4)
● 30	Throttle Lever	HU-556	* Winch Nameplate
31	Throttle Lever Latch	HU-869	* Nameplate Screw (4)
● 32	Throttle Lever Latch Spring	HU-567	* Winch Nameplate
33	Throttle Lever Set Screw	HU-842	* Nameplate Screw (4)
34	Throttle Lever Pin	HU-870	* Caution Plate
*	Throttle Lever Pin Cotter (2)	D02-524	* Caution Plate Screw (4)
			R4K-302

* Not illustrated.

† For Valve Chest (10) with Poppet-Type Throttle Valve (20), used beginning serial 7000 and illustrated in the sectional views. Parts for the superseded Valve Chest with taper-plug type Throttle Valve that was used under serial 7000 are no longer available. When any part is required for the superseded Valve Chest, order the listed Valve Chest Assembly. It can be used as a replacement for the assembly with taper-plug type Valve, provided a new Throttle Control Arm (28) is also used.

● To keep downtime to a minimum, it is desirable to have on hand certain repair parts. We recommend that you stock one (pair or set) of each part indicated by a bullet (●) for every four tools in service.

BASE, ROPE DRUM AND GEAR PARTS

PART NUMBER FOR ORDERING

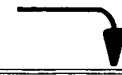

65	Base	for K4U or K5U.	K4U-564A
		for K4UL or K5UL.	K4UL-564A
66	Motor Mounting Bracket		K4U-502
67	Rope Drum		
		for K4U or K5U.	K5U-324
		for K4UL or K5UL.	K5UL-324
68	Wire Rope Set Screw (2).		215-140
69	Drum Shaft		
		for K4U or K5U.	K4U-459
		for K4UL or K5UL.	K4UL-459
*	Drum Shaft Oil Seal (2).		K4UL-271
70	Drum Packing.		207-136
●	71 Drum Bearing (2) (Hyatt CW99212 or its equivalent).		K4U-466
73	Drum Bearing Plate (4).		K4U-469
74	Drum Shaft Short Set Screw		HU-867
75	Drum Shaft Long Set Screw		HU-868
76	Motor Shaft		
		for K4U or K5U.	K4U-316C
		for K4UL or K5UL.	K4UL-316C
77	Motor Pinion Key.		EEG-768
78	Motor Shaft Pinion.		K4U-319B
●	79 Motor Shaft Bearing		K4U-589B
*	Motor Shaft Bearing Seal		R10V-310
80	Intermediate Gear		K4U-364
81	Intermediate Gear Bushing		K4U-363
82	Intermediate Gear Bushing Retainer.		K4U-362
83	Fiber Washer		K4U-871
84	Gear Case		K4U-353A
85	Gear Case Screw (10)		215-148
86	Lock Washer (10)		D10-322
87	Gear Cover		K4U-352
88	Grease Fitting		23-188
89	Drive Shaft		K4U-358
90	Clutch Jaw Lock Ball.		G601-65
91	Clutch Jaw Lock Spring		K4U-863
92	Clutch Jaw Lock Plug		HU-864
●	93 Drive Shaft Inner Bearing		2325-41
●	94 Drive Shaft Outer Bearing.		215-63
95	Clutch Jaw		K4U-568
96	Clutch Eccentric Shaft.		HU-857
97	Clutch Eccentric Roller		HU-858
98	Clutch Eccentric Pin		HU-859
99	Eccentric Pin Lock Screw		HU-860
100	Clutch Lever		HU-565
101	Clutch Latch		HU-566
102	Latch Spring		HU-567
103	Clutch Lever Pin		HU-861
104	Eccentric Shaft Lock Screw.		HU-865
105	Base Bolt (3/4"-10 thd. 3-1/2" long [8]).		K4U-775
106	Base Bolt Nut (8).		DU-562
107	Base Bolt Lock Nut Washer (8).		D01-692
108	Grease Plug (2).		22SR-165
109	3/8" Lock Washer		D02-321
110	Drive Shaft Nut.		215-73
111	Drive Shaft Nut Lock		215-74
112	Drum Bearing Retainer (2)		K4U-340
*	Grease Gun		P25-228
*	Wire Rope Set Screw Wrench.		K-27
*	Valve Chest Jack Bolt (2 required).		HU-932
*	Piston Ring Compressor.		KU-933
*	Throttle Valve Stem Reamer		23470
*	Throttle Valve Seat Reamer.		25670

* Not illustrated.

● To keep downtime to a minimum, it is desirable to have on hand certain repair parts. We recommend that you stock one (pair or set) of each part indicated by a bullet (●) for every four tools in service.

BRAKE PARTS

PART NUMBER FOR ORDERING

		↓	↓
		K4U K4UL	K5U K5UL
	Brake Band Assembly	K4U-A152	K5U-A152A
● 115	Brake Band	K4U-152	K5U-152A
116	Brake Lining	K4U-155	K4U-155
117	Brake Lining Short Rivet (16)	K4U-156	K4U-156
118	Brake Lining Long Rivet (17)	235-98	235-98
119	Brake Support Spring Bracket	K4U-161A	K4U-161A
120	Spring Bracket Rivet (2)	107-153	107-153
120	Brake Shoe Rivet (13)	107-153	107-153
● 121	Brake Shoe	K4U-145	K5U-145
122	Brake Shoe Rivet (9)	107-153	KU-542
118	Brake Lining Long Rivet (12)	235-98	235-98
123	Brake Lever Bracket	K4U-193	K5U-193
124	Brake Lever Bracket Rivet (5)	107-153	107-153
125	Brake Lining Long Rivet (5)	235-98	235-98
● 126	Brake Handle	107-151	107-151
127	Brake Handle Pin	107-149	107-149
128	Brake Handle Pin Cotter (2)	107-146	107-146
129	Brake Yoke	107-159	107-159
130	Brake Adjusting Screw	107-158	107-158
131	Brake Shoe Long Pin	107-147	107-147
132	Brake Shoe Pin Cotter (2)	D02-330	D02-330
133	Brake Anchor	K4U-206	K4U-206
134	Brake Anchor Nut	HU-776	HU-776
135	Brake Anchor Lock Washer	A-67	A-67
136	Brake Support Screw	K4U-162	K4U-162
137	Brake Support Screw Jam Nut	G7-18	G7-18
138	Brake Support Screw Washer	K4U-343	K4U-343
139	Brake Support Spring	T03-119	T03-119
140	Brake Lever Bracket Pin	107-148	107-148
*	Bracket Pin Cotter	107-146	107-146

* Not illustrated.

- To keep downtime to a minimum, it is desirable to have on hand certain repair parts. We recommend that you stock one (pair or set) of each part indicated by a bullet (●) for every four tools in service.

WARNING

DISENGAGING CLUTCH PARTS

For reasons of safety, it is emphatically recommended that Automatic Brake and Disengaging Clutch features not be used on any Winch used for hoisting or otherwise subjected to an overhauling load. If for any reason the Disengaging Clutch is left operative in a Winch used under either of the above conditions, it is the responsibility of the user to make provision to prevent accidental operation of the Winch motor with the clutch disengaged. **Operation of the motor with the clutch disengaged while holding a suspended load will allow the load to drop.**

Because the combination of Automatic Brake and Disengaging Clutch is not sanctioned, the three parts marked “†” should be ordered and installed if conversion from manual to automatic brake is made on a Winch equipped with the engaging clutch.

Use the parts as follows:

Install the Clutch Jaw Spacer (251) between the Drive Shaft Outer Bearing (94) and the Clutch Jaw (95) on the Drive Shaft (89) to lock the Clutch Jaw in engagement with the Intermediate Gear (80).

Remove the Clutch Eccentric Shaft (96) and included parts along with the Clutch Lever (100). Insert the Gear Cover Plug Seal (253) and Plug (252) into the hole in the Gear Cover (87) previously occupied by the Eccentric Shaft.

REMOTE CONTROL PARTS

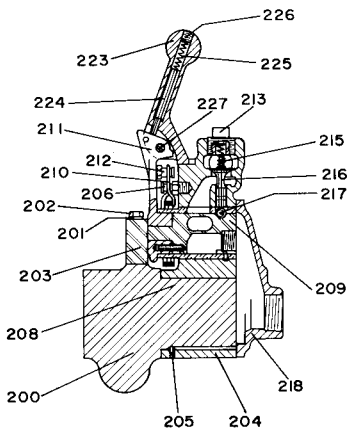

Remote Control Block Assembly

(Dwg. TPD201)

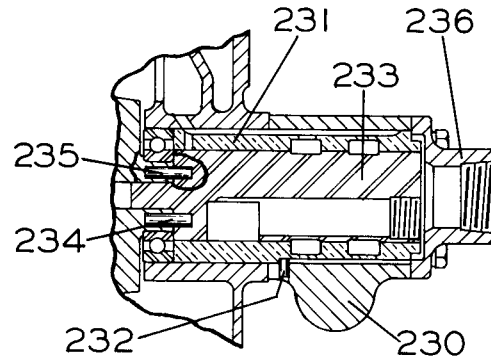

Remote Control Valve Chest Assembly

(Dwg. TPD206)

PART NUMBER FOR ORDERING



	Remote Control Block Assembly	
	for Winch with Standard Brake	KU-A685
	for Winch with Automatic Brake	KU-B685
200	Remote Control Block	KU-685
201	3/8" Lock Washer (2)	D02-321
202	Control Arm Retainer Screw (2)	HU-865
203	Control Arm Retainer	HU-687
204	Control Block Valve Chest	KU-876A
205	Bushing Key	HU-538
*	Brake Inlet Plug	D02-402
206	Throttle Lever Spring Stop Pin	D02-553
208	Control Block Reverse Valve Bushing	KU-945
*	Grease Fitting (2)	23-188
209	Control Block Reverse Valve	
	for Winch with Standard Brake	KU-944
	for Winch with Automatic Brake	KU-744
210	Control Block Throttle Lever Spring	KU-412
211	Control Block Throttle Arm	KU-555A
	Throttle Lever Spring Stop Pin	D02-553
212	Control Block Throttle Valve Cap	KU-943
215	Control Block Throttle Valve Spring	HU-942
216	Control Block Poppet Throttle Valve	KU-940
217	Control Block Throttle Valve Ball	D10-280
218	Control Block Valve Chest Cover	KU-546A
223	Control Block Throttle Lever	HU-556
224	Throttle Lever Latch	HU-869
225	Latch Spring	HU-567
226	Throttle Lever Set Screw	HU-842
227	Throttle Lever Pin	HU-870
*	Throttle Lever Pin Cotter (2)	D02-524
230	Remote Control Valve Chest	
	for K4U or K4UL	KX-545
	for K5U or K5UL	K5M-545
231	Rotary Valve Bushing	
	for K4U or K4UL	KU-525S
	for K5U or K5UL	K5M-525S
232	Bushing Key	HU-538
233	Rotary Valve	
	for overwinding Winch	KU-526A
	for underwinding Winch	KU-526RA
234	Large Valve Drive Pin	KU-527
235	Small Valve Drive Pin (2)	HU-527
236	Remote Control Valve Chest Cover	KX-546
*	Valve Chest Screw (4)	KU-548
*	1/2" Lock Washer (4)	D10-322

* Not illustrated.

AUTOMATIC BRAKE PARTS

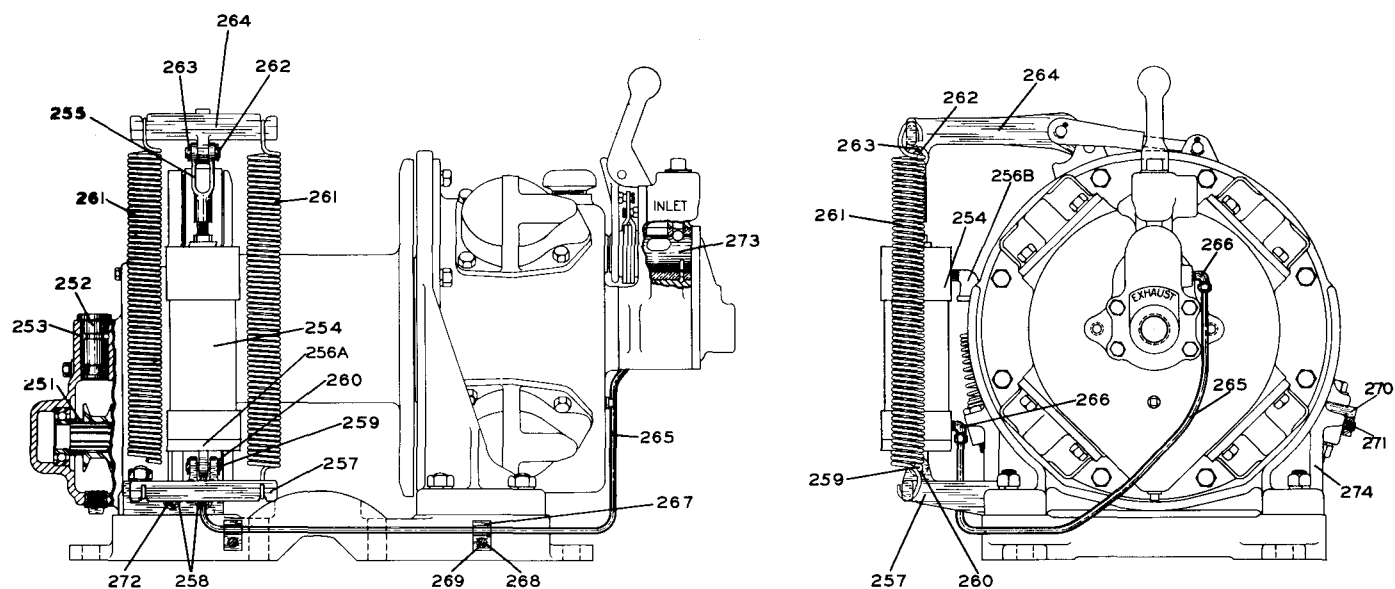

(Dwg. TPA742-1)

PART NUMBER FOR ORDERING

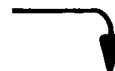

‡ 251	Clutch Jaw Spacer	K4U-712
‡ 252	Gear Cover Plug	HU-728
‡ 253	Gear Cover Plug Seal	HU-730
● 254	Brake Cylinder Assembly	HU-720A
255	Brake Cylinder Yoke	HU-719
* 256A	Brake Cylinder Bushing	HU-771
256B	Eye Bracket	HU-717
257	Street Elbow	HUS-912
258	Brake Cylinder Bracket	K4U-721
259	Brake Cylinder Bracket Cap Screw (2)	HU-723
260	Brake Cylinder Bracket Pin	HU-870
261	Bracket Pin Cotter (2)	D02-524
262	Brake Spring (2)	K4U-726
263	Yoke Pin	22-720
264	Yoke Pin Cotter	D02-330
265	Automatic Brake Lever	K4U-718
266	Brake Pipe	
	for K4U or K5U	K4U-401
	for K4UL or K5UL	K4UL-401
267	Brake Pipe Elbow (2)	K4U-400
268	Brake Pipe Strap (2)	HU-727
269	Strap Screw (2)	J-376
270	1/4" Lock Washer (2)	L01-67
271	1/2" Lock Washer	D10-322
272	Automatic Brake Reverse Valve	KU-744
273	Reverse Valve O-ring	R18-311
274	Motor Mounting Bracket	K4U-502
*	Brake Cylinder Bracket Bolt (3/4"-10 thd. x 4" long)	K6U-775

* Not illustrated.

● To keep downtime to a minimum, it is desirable to have on hand certain repair parts. We recommend that you stock one (pair or set) of each part indicated by a bullet (●) for every four tools in service.

‡ Refer paragraph 2 of DISENGAGING CLUTCH PARTS on Page 9.

BRAKE EXHAUST VALVE PARTS

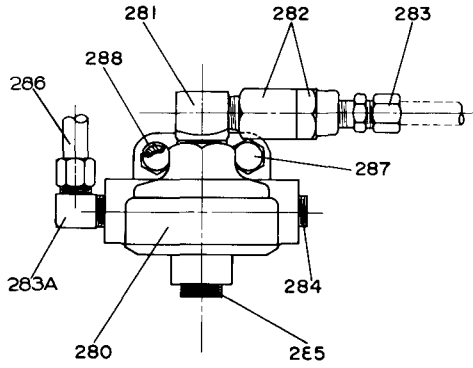

(Dwg. TPD214-1)

PART NUMBER FOR ORDERING

	Brake Exhaust Valve Assembly	K4U-A733
280	Brake Exhaust Valve	HU-733
281	Exhaust Valve Elbow	HU-745
282	Brake Air Strainer Assembly	ROB2-A565
283	Brake Connection	K4U-711
284	1/4" Pipe Plug	D02-402
285	Orifice Plug	HU-732
286	Exhaust Valve Pipe	K4U-731
287	Exhaust Valve Cap Screw (2)	R55H-473
288	5/16" Lock Washer (2)	T11-58
† 266	Brake Pipe Elbow	K4U-400

† Illustrated on Page 11.

PULL CHAIN THROTTLE PARTS

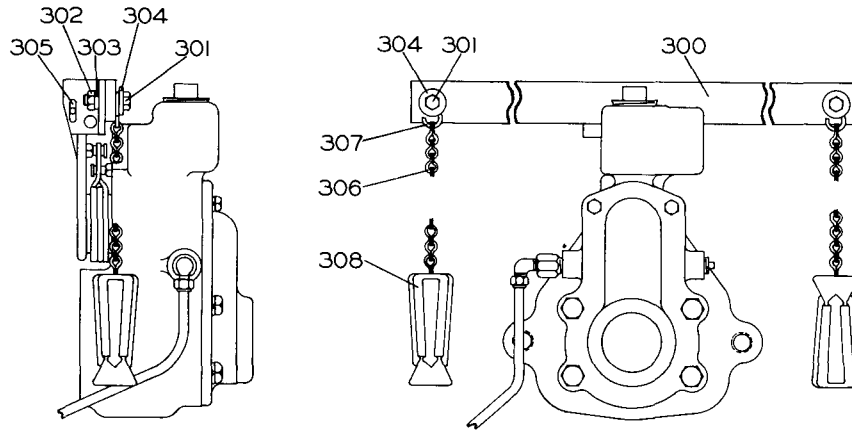

(Dwg. TPC112)

PART NUMBER FOR ORDERING

300	Pull Chain Throttle Lever	HU-559
301	Throttle Chain Bolt (2)	D02-312
302	Throttle Chain Bolt Nut (2)	D02-418
303	3/8" Lock Washer (2)	D02-321
304	3/8" Plain Washer (2)	D02-419
305	Throttle Lever Cotter	215-124
306	Throttle Lever Chain (2) (length as specified)	DU-413
307	S-Hook (4)	D01-221
308	Throttle Handle (2)	MR-415

AIR STRAINER

PART NUMBER FOR ORDERING

400	Air Strainer Assembly	K4U-A267AT
401	Air Strainer Screen	K4U-61AT
403	Air Strainer Plug	22SR-165
404	Air Strainer Cap	K4U-268AT
*	Air Strainer Nipple (1-1/4" x 2-1/2").	KKM-286

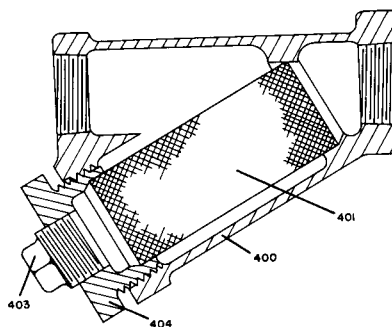

* Not illustrated.

(Dwg. TPD122-1)

WIRE ROPE AND FITTINGS

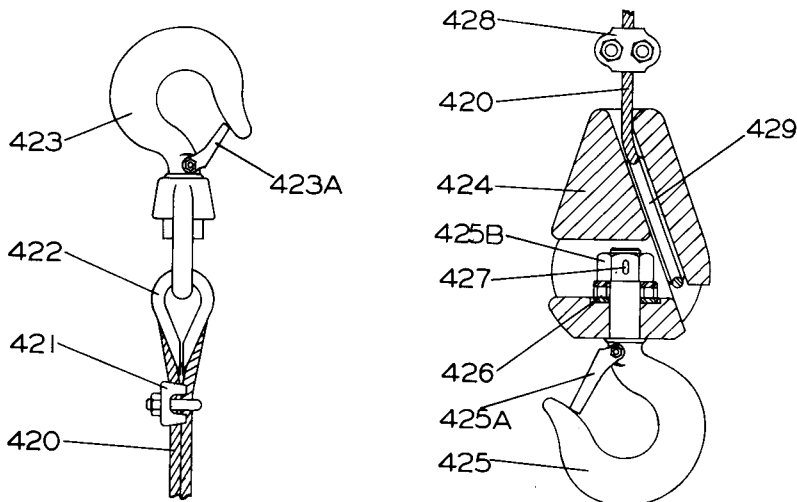

(Dwg. TPC146-2)

PART NUMBER FOR ORDERING

		For Use With 3/8" Dia. Wire Rope	For Use With 1/2" Dia. Wire Rope	For Use With 9/16" Dia. Wire Rope	For Use With 5/8" Dia. Wire Rope
420	Wire Rope (specify length)	EU-372	215-372	K4U-372	235-372
	Wire Rope Fitting Assembly	EU-AS601	K4U-AS601-1/2	K4U-AS601-9/16	K4U-AS601-5/8
421	Wire Rope Clamp (3)	D04-464	D20-375	D20-375	235-375
422	Rope Thimble	D10-721	215-602	K4U-602	K4U-602
423	Swivel Hook	D01C-S377	K4U-S601	K4U-S601	K4U-S601
423A	Hook Latch Kit (individual parts not sold separately)	D01-S4055	D02-S4055	- - -	- - -
	Hook Block Assembly	D02-AS463A	D04-AS463A	- - -	- - -
424	Hook Block	D02-463A	D04-463A	- - -	- - -
425	Hook	D02-S377	D04-S377	- - -	- - -
425A	Hook Latch Kit	D02-S123	D04-S123	- - -	- - -
425B	Hook Nut	D02-305B	HRA60A-305	- - -	- - -
426	Hook Bearing	D02-379A	D04-379A	- - -	- - -
427	Roll Pin	20QDM-330	D02-374	- - -	- - -
428	Wire Rope Clamp	D04-464	D20-375	- - -	- - -
429	Wire Rope Wedge	D02-373	D02-373	- - -	- - -

DRUM GUARDS

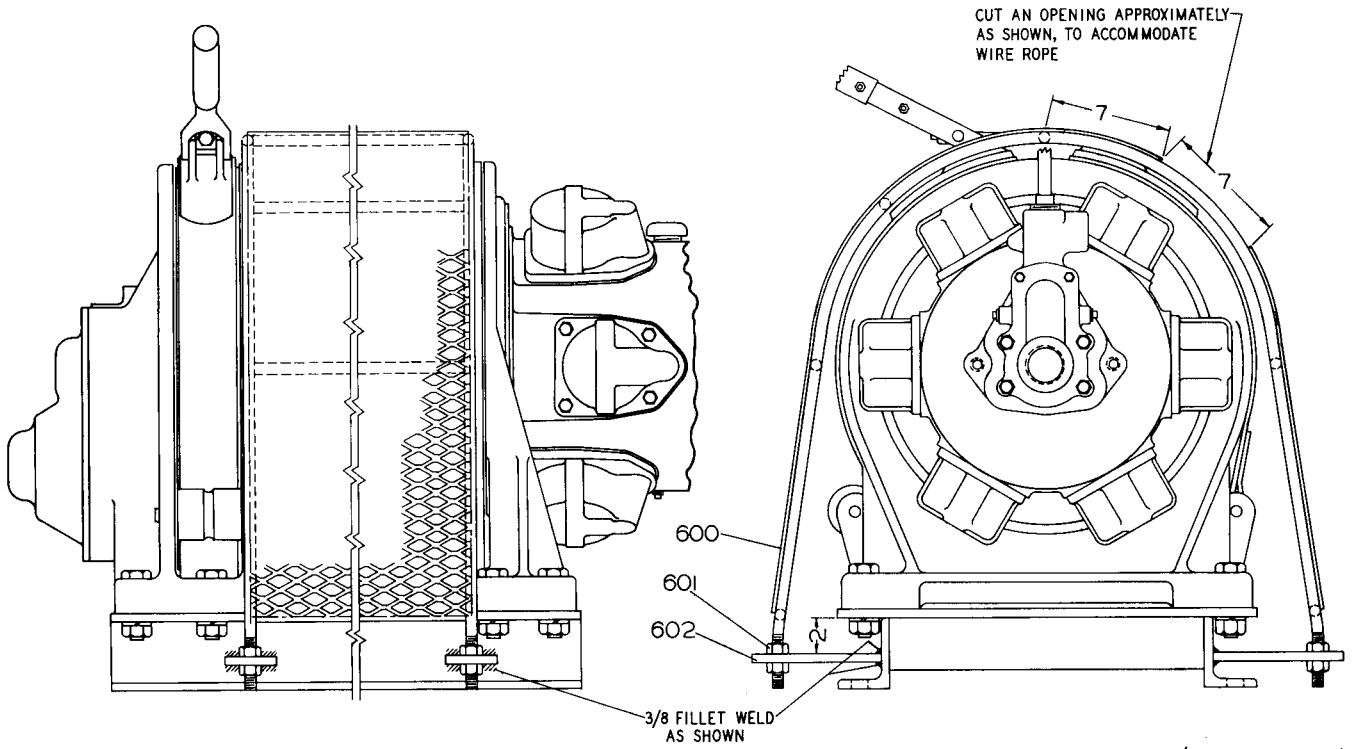

(Dwg. TPB565)

PART NUMBER FOR ORDERING

600	Drum Guard for K4U or KSU.	K4U-298
	for K4UL or KSUL.	K4UL-298
601	5/8"-11 thd. Nut (8)	K6U-8
602	Plate (4)	K6U-299

MUFFLER

PART NUMBER FOR ORDERING

Muffler	KU-674
† Muffler Nipple.	KKM-286
† Reducing Coupling	HU-677

† Not required except when Winch is equipped for Remote Control.



INGERSOLL-RAND

Power Tool Division
28 Kennedy Blvd.

East Brunswick, N. J. 08816

Atlanta, Ga.
111 Ingersoll-Rand Drive
Chamblee, Georgia 30341

Chicago, Ill.
888 Industrial Drive
Elmhurst, Illinois 60126

Philadelphia, Pa.
651 Park Ave.
King of Prussia, Pa. 19406

Seattle, Wash. 98188
345 Andover Park East

Baton Rouge, La. 70816
4252 Rhoda Drive

Dallas, Texas 75247
8901 Directors Row

Pittsburgh, Pa. 15220
6 Parkway Ctr.

Shreveport, La. 71106
454 W. 61st St.

Boston, Mass.
2 Kuntzhol Dr.
Holliston, Mass. 01746

Denver, Colo. 80207
5805 E. 39th Ave.

Portland, Oregon 97214
240 S. E. Clay St.

Syracuse, N. Y. 13208
505 Factory Ave.

Charlotte, N. C. 28208
4840 Wilmont Rd.

Detroit, Mich.
22122 Telegraph Road
Southfield, Mich. 48075

Las Angeles, Calif. 90022
5533 East Olympic Blvd.

Newark, N. J.
28 Kennedy Blvd.
East Brunswick, N. J. 08816

Salt Lake City, Utah 84115
3007 South West Temple
Suite G

St. Louis, Mo. 63132
1515 Page Industrial Blvd.

Chattanooga, Tenn. 37408
1936 Central Ave.

Houston, Texas 77001
6800 Sands Point, P.O. 1455

Milwaukee, Wis.
N84 W13540 Leon Rd.
Menomonee Falls, Wis.
53051

New Orleans, La. 70005
939 Lake Ave. Metairie

San Francisco, Calif.
14299 Wicks Blvd.
San Leandro, Calif. 94577

Washington, D. C. 20006
1666 K. St., N. W.

Minneapolis, Minn. 55404
Corner Franklin & Cedar

Norfolk, Va.
1431C Air Rail Ave.
Virginia Beach, Va. 23455

Regional Sales Office and All-Star Servicenter.
* All-Star Servicenter only.

CANADA

Calgary, Alberta, T2R 0E1
611 11th Ave., S. W.

Shorebrook, Quebec
375 Courcelle St., J1H 3X4
Box 1500, J1H 3M3

Ingersoll-Rand Canada Inc.
Montreal, Quebec, H3B 1S6
630 Dorchester Blvd. West

Toronto
Don Mills, Ontario M3B 2V1
255 Lesmill Road

Vancouver
British Columbia, V6A 2W7
1695 Main St.

Montreal, Quebec
620 Cathcart St., H3B 1M2
P.O. Box 1148, H3B 3K9

Sudbury, Ontario, P3A 3T3
P.O. Box 2220

Winnipeg, Manitoba, R3M 0M6
1234 Border St.

All-Star Servicenter.

AUTONOMOUS COMPANIES

Argentina, Buenos Aires
Ingersoll-Rand Argentina
S.A.I.y C.
Casilla Correo 2412, Correo Central

Australia, South Melbourne
Ingersoll-Rand (Australia) Ltd.
P.O. Box 219
42 Moray Street, 3205 Victoria

Austria A 1120, Vienna
Ingersoll-Rand Ges M.B.H.
Schoenbrunnerstrasse 213-215/2/5

Belgium, Diegem (Brussels)
Ingersoll-Rand Benelux S.A.
Kouterveldstraat 10-12, 1920 Diegem

Brazil, Sao Bernardo
Ingersoll-Rand S.A. Ind. e Com.
Caixa Postal 911

Chile, Santiago
Ingersoll-Rand Chile
Morande 341
Casilla 126-D

Colombia, Bogota
Macquinarias Ingersoll-Rand
de Colombia, S.A.
Apartado Aero 7451

Denmark, Albertslund DK2620
Ingersoll-Rand AB
Herstedvang 11

Egypt, Cairo
Ingersoll-Rand North East Africa
P.O. Box 820
23A Ismail Mohamed St.
Zamalek

England, London, SW1X, 7LU
Ingersoll-Rand Co., Ltd.
Bowater House, Knightsbridge

France, 78 190 Trappes Yvelines
Compagnie Ingersoll-Rand
Avenue Albert Einstein
Zone Industrielle

Germany, 403 Ratingen
Ingersoll-Rand GmbH
Robt. Zapp Str. 7
Postfach 1380

Greece, Athens 610
Ingersoll-Rand Central Middle East
17th Floor Athens Tower
Mesogion 2-4

Hong Kong
Ingersoll-Rand Far East
19th Floor, Lap Heng House
50, Gloucester Road

India, Bombay 400018
Ingersoll-Rand (India) Private Ltd.
44 Maulana Abdul Gaffar Rd.
P.O. Box 16564, Worli

Ireland, Dublin
Ingersoll-Rand Company (Ireland) Ltd.
John F. Kennedy Drive
Bluebell

Italy, 20100 Milano
Ingersoll-Rand Italiana, S.p.A.
Strada Provinciale Cassanese
Caselle Postale 1232
Vignate, Italy

Japan, 106 Tokyo
Ingersoll-Rand (Japan) Ltd.
Kowa Bldg. No. 17
2-7 Nishi-Azabu 1-Chome
Minato-Ku

Kenya, Nairobi
Ingersoll-Rand Mid Africa
P.O. Box 14240

Malaysia, Petaling Jaya
Ingersoll-Rand Malaysia, Sdn. Bhd.
P.O. Box No. 125

Mexico, 10 D.F. Mexico
Ingersoll-Rand S.A. de C.V.
Apartado 41-666

Netherlands, Zoeterwoude
Ingersoll-Rand Benelux N.V.
P.O. Box 33, Zoeterwoude

Norway, Oslo 1
Ingersoll-Rand AB
P.O. Box 143-Sentrum

Peru, Lima
Ingersoll-Rand Co. of Peru, S.A.
Casilla 2261

Philippines, Makati, Rizal 3117
Ingersoll-Rand Philippines, Inc.
P.O. Box 445 MCC

Portugal, Lisbon 5
Ingersoll-Rand Lda.
Apartado 2933

Puerto Rico, San Juan 00936
Ingersoll-Rand de Puerto Rico Inc.
G.P.O. Box 1222

Singapore 22
Ingersoll-Rand Southeast Asia (Pte.) Ltd.
G.P.O. Box 2062, Singapore 1

South Africa, Alberton
Ingersoll-Rand Co. S.A. (Proprietary) Ltd.
P.O. Box 3720
Alrode, 1451

Spain, Madrid
Cia. Ingersoll-Rand, S.A.
Apartado 518

Sweden, Bromma
Ingersoll-Rand A.B.
Fack
S-16125 Bromma 1

Venezuela, Caracas
Ingersoll-Rand de Venezuela S.A.
Apartado 70588, Los Ruices

Distributors in principal cities throughout the world. Contact the nearest Ingersoll-Rand office for the name and address of the distributor in your country or write to Ingersoll-Rand International, Woodcliff Lake, New Jersey.

AUTHORIZED I-R SALES AND SERVICE

INGERSOLL-RAND