

# UTILITY® WINCHES

## MODELS D6U, D6UL, EU, EUL, EUA AND EUAL

### WARNING

***These Winches are not to be used  
for lifting or lowering people***

**Always operate and maintain this Winch in accordance with American National Standards Institute Safety Code (ANSI B30.7) and any other applicable safety codes and regulations.**

**FOR TOP PERFORMANCE AND MAXIMUM DURABILITY OF PARTS, OPERATE THIS WINCH AT 90 psig (6.2 bar/620 kPa) AIR PRESSURE WITH 1" (25 mm) DIAMETER HOSE.**

### OPERATING PRACTICES

The two most important aspects of Winch operation are: (1) Allow only qualified people to operate a Winch and (2) Subject each Winch to a regular inspection and maintenance procedure.

A qualified operator must be physically competent. He must have no health condition which might affect his ability to react, and he must have good hearing, vision and depth perception. The qualified Winch operator must be carefully instructed in his duties and must understand the operation of the Winch, including a study of the manufacturer's literature. He must thoroughly understand proper methods of hitching loads. He should have a good attitude regarding safety and should refuse to operate under unsafe conditions.

Regular inspection procedures should be set up, rigidly adhered to and recorded by or under direction of a qualified person. On Winches a continuous service, inspection should be made at the beginning of each shift. The items to be checked include, but are not limited to:

- a. **LUBRICATION:** See lubrication instructions on Page 3.
- b. **BRAKES:** Visually check for proper adjustment.  
Lift a capacity or near capacity load a few inches off the floor and check ability of braking system to stop and hold the load without excessive drift.
- c. **WIRE ROPE AND HOOKS:** Visually inspect the wire rope. Replace it **AT ONCE** if there is indication of fraying, or if it is crushed, cut or otherwise damaged. Follow cable manufacturer's recommended practice for proper use and inspection of wire rope.  
Hooks should be checked for wear, increase in throat opening, and bending.
- d. **CONTROLS:** See that controls function properly and return to neutral when released.
- e. **GENERAL:** Check to see that mounting fastenings are secure, unworn and undamaged. Be alert for unusual visual or audible signs which could indicate a defect. Do not operate the Winch until the defect has been determined and corrected.

Periodically, depending on the severity of the service:

- a. Inspect Brake and Locking Dog components for wear or damage.
- b. Check all bolts or fasteners.
- c. Inspect the Winch structure for damage.

**Notice:** The use of other than genuine Ingersoll-Rand replacement parts may result in decreased tool performance and increased maintenance, and may, at the Company's option, invalidate all warranties.

Refer All Communications to the Nearest  
Ingersoll-Rand Office or Distributor.

© Ingersoll-Rand Company 1981

Printed in U.S.A.

**INGERSOLL-RAND®**  
**AIR WINCHES**

**P  
A  
R  
T  
S  
  
B  
U  
L  
L  
E  
T  
I  
N**

## OPERATING INSTRUCTIONS

1. Read the manufacturer's instructions before operating the Winch.
2. Never lift a load greater than the rated capacity of the Winch.
3. Never use the Winch rope as a sling.
4. Always stand clear of the load.
5. Never use the Winch for lifting or lowering people, and never stand on a suspended load.
6. Never carry loads over people.
7. Before each shift, check the Winch for wear or damage. Check brakes, locking dog, etc.
8. Periodically inspect the Winch thoroughly and replace worn or damaged parts.
9. Follow the lubrication instructions.
10. Do not disengage clutch with a load on the Winch. Be sure clutch is fully engaged before operating Winch.
11. Do not "side pull" or "yard".
12. Always rig the Winch properly and carefully.
13. Never operate a Winch with twisted, kinked or damaged wire rope.
14. Be sure cable winds properly on drum.
15. Ease the slack out of the wire rope and sling when starting a lift. Do not jerk the load.
16. Be certain there are no objects in the way of a load or hook when operating the Winch.
17. Be certain the air supply is shut off before performing maintenance work on the Winch.
18. Shut off air supply while Winch is unattended.
19. Properly secure the Winch before leaving it unattended.
20. Be certain the load is properly seated in the saddle of the hook. Do not tiplod the hook as this leads to spreading and eventual failure of the hook.
21. Do not allow unqualified personnel to operate a Winch.
22. Do not swing a suspended load.
23. Do not operate a Winch if you are not physically fit to do so.
24. Do not do anything you believe may be unsafe.
25. Do not use the Winch rope as a ground for welding. Do not attach a welding electrode to a Winch or sling chain.
26. Do not divert your attention from the load while operating a Winch.
27. Engage locking dog before leaving load suspended.
28. Do not engage locking dog while drum is in operation.
29. Do not leave a load suspended for any extended period—never unattended.
30. Never splice a sling chain by inserting a bolt between links.
31. Do not force a chain or hook into place by hammering. Do not insert the point of the hook into a chain link.
32. Do not expose the sling chain to freezing temperatures, and do not apply sudden loads to a cold chain.

## PARTS WITH PROTECTIVE COATING

All exposed parts originally furnished on an EUAB/PT Winch were given a special protective coating to help prevent rust and corrosion. When ordering replacement parts that originally had the special protective coating, **Protective Coating Must Be Specified On The Order**. Failure to do so will result in replacement parts being furnished without the special protective coating.

Lubricate the motor before putting the Winch in service. To prevent leakage during shipment, the oil was drained from the Motor Case (1). Sufficient oil for one filling is contained in the can packed with the Winch. Before operating the Winch, unscrew the Vent Cap (3) from the top of the Motor Case and pour the entire contents of the can into the motor.

## LUBRICATION

### Motor Lubricants

For temperatures 30° F to 80° F (-1.1° C to 26.6° C), use Ingersoll-Rand Medium Oil No. 50 or SAE 20 or 20W motor oil.

For temperatures above 80° F (26.6° C), use SAE 30 motor oil.

For temperatures below 30° F (-1.1° C), use SAE 10 or 10W motor oil.

Check the oil level daily as follows:

#### When the Winch is not subjected to freezing temperatures.

After the Winch has been idle for several hours or overnight, remove the Drain Plug (2) and allow the accumulated water to drain out. Replace the Drain Plug at the bottom and remove the one from the side of the Motor Case. Remove the Vent Cap (3) and pour a sufficient quantity of the recommended lubricant into the vent, to bring the level of the oil up to the drain plug hole in the side of the Motor Case. Replace the Drain Plug and Vent Cap.

#### When the Winch is subjected to freezing temperatures.

Allow the Winch to remain idle long enough for the water to separate from the oil, but not long enough for it to freeze. Drain the water and replenish the oil as in the preceding paragraph. Should this procedure be impractical, drain the entire contents of the Motor Case immediately after operation ceases, and replace it before resuming operation. If the Motor Case is not drained, a sufficient quantity of water will eventually accumulate so that the Oil Splasher (34), which is attached to the Crank (29) will freeze fast.

### Twice Weekly

Insert two or three strokes of Ingersoll-Rand Light Grease No. 28 or a good quality No. 2 cup grease into the Grease Fittings (5 and 12) on the Valve Chest (4), and six or eight strokes into the Grease Fitting on the Rope Drum Cover (111) or Hub Bushing (100).

### Gear Case Lubrication

Approximately every sixty or ninety days, remove the Grease Plug (94) and note if the visible portion of the gears is covered with a film of grease. If the gears appear to lack lubrication, add about 1/2 pint (237 ml) of Ingersoll-Rand Gear Grease No. 70, Ingersoll-Rand Light Grease No. 28 or a good quality gear grease to the Gear Case.

For extremely low temperatures, where lubrication difficulty might be experienced with the above grease, Ingersoll-Rand Medium Gear Grease No. 75, low temperature grease such as Texas Regal Star Special, or a good quality, heavy gear oil may be used as a substitute. **Note:** If gear oil is used, leakage will probably result when the Winch is again subjected to normal temperatures.

We recommend the use of an air line lubricator with all Winches.

## OPERATING INSTRUCTIONS

Whenever the Winch is mounted in any manner other than the normal upright position, remove the eight Motor Case Cap Screws (59 and 60) and rotate the motor on the Motor Case Cover (57) until the Vent Cap (3) is at the top; then replace the Cap Screws.

Be sure to apply the wire rope so that it winds on the Drum in the right direction as indicated by the instruction plate on the Winch.

Never engage or disengage the clutch while either the motor or Rope Drum is in motion. Doing so may result in damage.

When lowering loads, keep the clutch engaged and operate the motor in the lowering direction. Disengaging the clutch and controlling the lowering speed of the load with the brake, taxes the brake beyond its intended capacity.

*(continued on page 22)*

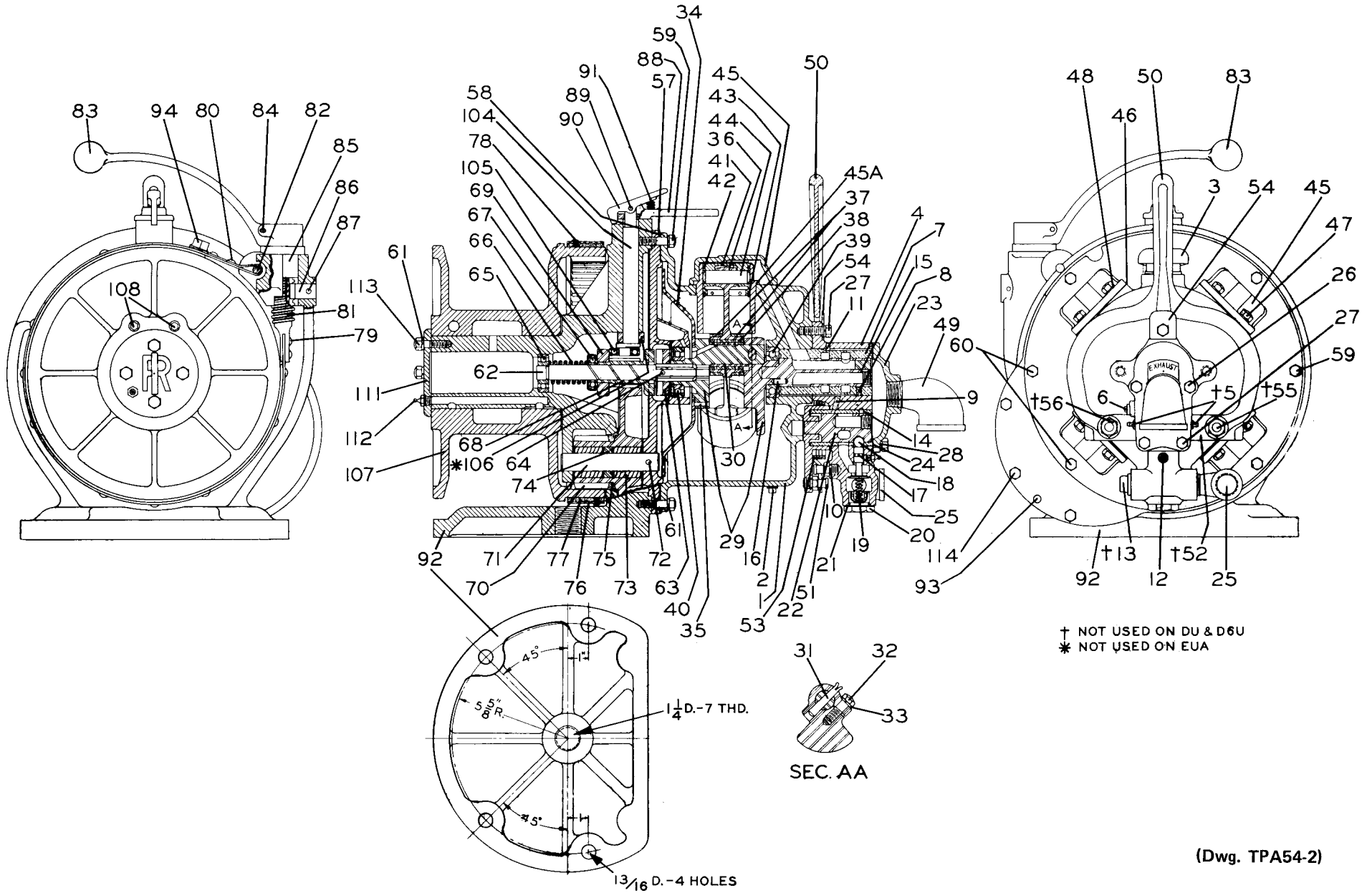

D6U and EUA Utility Winches  
Over Serial 5000

(Dwg. TPA54-2)

## MOTOR AND BRAKE PARTS

PART NUMBER FOR ORDERING

		↓ D6U, D6UL	↓ EU, EUL, EUA, EUAL
†	Motor Assembly		
	for D6U and D6UL . . . . .	D6U-A501A	-----
† 1	for EU, EUA, EUL and EUAL . . . . .	-----	EU-A501
	Motor Case . . . . .	D02-501A	D10-501
2	Drain Plug (3) . . . . .	D02-402	D02-402
3	Vent Cap . . . . .	D02-303A	D02-303A
*	S-Hook . . . . .	D02-421	D02-421
*	Vent Cap Screen . . . . .	D02-889	D02-889
*	Vent Cap Chain . . . . .	D02-891	D02-891
*	Screen Retainer . . . . .	6CND-233-1/2	6CND-233-1/2
*	Vent Cap Cotter (1/8" x 1/2") . . . . .	D02-893	D02-893
	Valve Chest Assembly . . . . .	DU-A545A	EU-A545A
■ 4	Valve Chest . . . . .	D02-545A	D10-545A
■ 5	Grease Fitting (2) . . . . .	-----	23-188
■ 6	Brake Inlet Plug . . . . .	TC-368	D02-402
■ 7	Rotary Valve Bushing . . . . .	D02-525AS	D10-525AS
■ 8	Valve Oiler . . . . .	JA4-75	JA4-75
■ 9	Valve Oiler . . . . .	JA4-75	-----
■ 10	Throttle Spring Stop Pin . . . . .	D02-553	D02-553
■ 11	Valve Bushing Key (2) . . . . .	D02-538	B12-255
■ 12	Small Grease Fitting . . . . .	R1-188	R1-188
■ 13	Valve Chest Plug . . . . .	-----	22SR-165
■ 14	Reverse Valve Bushing . . . . .	D02-945S	D10-945-5S
■ 15	Rotary Valve . . . . .	D02-526	D10-526
■ 16	Valve Drive Pin . . . . .	D02-527	D10-527
■ 17	Poppet Throttle Valve . . . . .	D02-940	D02-940
■ 18	Throttle Valve Ball (1/2" dia. steel ball) . . . . .	D10-280	D10-280
■ 19	Throttle Valve Spring . . . . .	B01-11	B01-11
■ 20	Throttle Valve Cap . . . . .	D02-943	D02-943
■ 21	Throttle Valve Cap Gasket . . . . .	G601-411	G601-411
■ 22	Reverse Valve . . . . .	DU-944	EU-944
■ 23	Valve Chest Cover . . . . .	D02-546A	D10-546A
■ 24	Valve Chest Cover Gasket . . . . .	D02-928	D10-928
■ 25	Inlet Elbow . . . . .	DU-581	DU-581
■ 26	Valve Chest Long Screw (2) . . . . .	D02-548	D10-548
■ 27	Valve Chest Short Screw (3) . . . . .	D02-506	D02-506
■ 28	Valve Chest Cap Screw Lock Washer (5) . . . . .	D02-321	D02-321
	Crank Assembly		
	for D6U and D6UL . . . . .	D6U-A516	-----
	for EU, EUL, EUA and EUAL . . . . .	-----	EU-A516

\* Not illustrated.

† The complete size symbol of the Winch must be stated when ordering a Motor Assembly or Motor Case.

■ For Valve Chest (4) with Poppet-Type Throttle Valve (17), used beginning serial 5000 and illustrated in the sectional views. Parts for the superseded Valve Chest with Taper-Plug Type Throttle Valve used under serial 5000 are no longer available. Whenever any part is required for the superseded Valve Chest, order the listed Valve Chest Assembly. It can be used as a replacement for the assembly with taper-plug type valve.



## MOTOR AND BRAKE PARTS

PART NUMBER FOR ORDERING



		D6U, D6UL	EU, EUL, EUA, EUAL
29	Crank, Bare (consists of 2 matched pieces which are not sold separately)		
	for D6U and D6UL . . . . .	D06-516	-----
	for EU, EUA, EUL and EUAL . . . . .	-----	D10-516
30	Crank Pin Sleeve . . . . .	D02-519	D10-519
31	Crank Taper Pin . . . . .	D02-520	D10-520
32	Crank Pinch Bolt . . . . .	D02-521	D10-521
33	Crank Pinch Bolt Lock Washer . . . . .	D02-537	D10-322
★ 34	Oil Splasher . . . . .	D04-540	D10-540
35	Oil Splasher Rivet (3 for D6U and D6UL; 4 for others). . . . .	D06-541	D06-541
*	Counterweight Rivet (2) . . . . .	D06-554	-----
*	Counterweight . . . . .	D06-515	-----
35	Oil Splasher Rivet (3) . . . . .	D06-541	-----
*	Counterweight Rivet (2) . . . . .	D06-554	-----
36	Connecting Rod (4) . . . . .	D04-509	D10-509
37	Connecting Rod Ring (2) . . . . .	D02-510	D10-510
38	Connecting Rod Bushing . . . . .	D02-511	D10-511
39	Crank Valve End Bearing . . . . .	TA-22	D04-956
40	Crank Splined End Bearing . . . . .	C04-318	CE230-674
41	Piston Assembly (4) . . . . .	D06-A513B	D10-A513B
42	Piston Ring (1 for each Piston) . . . . .	D06-337	D10-337A
43	Oil Regulating Piston Ring (1 for each Piston) . . . . .	D06-338	D10-338
44	Piston Wrist Pin (4)		
	for Size DU . . . . .	D04-514A	-----
	for Sizes D6U and D6UL . . . . .	D06-514	-----
	for Sizes EU, EUL, EUA and EUAL . . . . .	-----	D10-514
	Cylinder Assembly (4) . . . . .	D06-A505A	D10-A505A
45	Cylinder Head . . . . .	D06-H505A	D10-H505A
45A	Cylinder Sleeve . . . . .	D06-L505A	D10-L505A
46	Cylinder Gasket (4) . . . . .	D02-507	D10-507
47	Cylinder Cap Screw (16) . . . . .	D02-506	D10-506
48	Cylinder Cap Screw Washer (copper) (16) . . . . .	D02-504	D10-504
49	Exhaust Elbow . . . . .	DU-587	DU-587
▲ 50	Throttle Lever . . . . .	EU-556	EU-556
51	Throttle Spring Stop Pin . . . . .	D02-553	D02-553

\* Not illustrated.

★ When ordering an Oil Splasher also order Oil Splasher Rivets and Counterweight Rivets as required.

▲ For D6U and D6UL: The throttle Lever with integral control arm that at one time was used on these Winches is no longer available. For replacement of the combination type Lever, use listed parts 50, 52, 55 (2) and 56 (2).

## MOTOR AND BRAKE PARTS

PART NUMBER FOR ORDERING

		↓	↓
		D6U, D6UL	EU, EUL, EUA, EUAL
52	Throttle Control Arm. . . . .	D02-555	D10-555
51	Throttle Spring Stop Pin. . . . .	D02-553	D02-553
53	Throttle Lever Spring. . . . .	D02-412B	D02-412B
54	Throttle Lever Guide . . . . .	DU-596	DU-596
55	Throttle Lever Bolt (2). . . . .	D02-411A	D02-411A
56	Throttle Lever Bolt Nut (2). . . . .	D02-418A	D02-418A
57	Motor Case Cover . . . . .	DU-502	EU-502
58	Motor Case Gasket. . . . .	D02-592	D10-592
59	Motor Case Long Screw (6). . . . .	D02-312	D10-312
60	Motor Case Short Screw (2). . . . .	D02-506	D02-312
61	3/8" Lock Washer . . . . .	D02-321	D02-321
62	Motor Shaft . . . . .	DU-316	EU-316
63	Clutch Jaw. . . . .	DU-568	EU-568
64	Clutch Jaw Pin . . . . .	DU-569	EU-569
65	Motor Shaft Bearing. . . . .	R4-24	R4-24
66	Clutch Spring . . . . .	DU-583	DU-583
67	Clutch Thrust Bearing (Timken T-76 or its equivalent). . . . .	D01-379A	D01-379A
68	Motor Shaft Pinion		
	for D6U and D6UL . . . . .	DU-319	-----
	for EU and EUL . . . . .	-----	EU-319
	for EUA and EUAL. . . . .	-----	EUA-319
69	Clutch Release Collar		
	for D6U and D6UL . . . . .	DU-584	-----
	for EU and EUL . . . . .	-----	EU-584
	for EUA and EUAL. . . . .	-----	EUA-584
70	Intermediate Gear		
	for D6U and D6UL . . . . .	DU-364	-----
	for EU and EUL . . . . .	-----	EU-364
	for EUA and EUAL. . . . .	-----	EUA-364
71	Intermediate Gear Shaft . . . . .	DU-365	DU-365
72	Intermediate Gear Shaft Pin . . . . .	DU-368	DU-368
73	Intermediate Gear Bearing (2) . . . . .	DU-366	DU-366
74	Intermediate Gear Bearing Spacer. . . . .	DU-593	DU-593
75	Intermediate Gear Packing . . . . .	DU-600	DU-600
	Brake Band Assembly. . . . .	DU-A574	DU-A574
76	Brake Band . . . . .	DU-574	DU-574
77	Brake Lining. . . . .	DU-575	DU-575
78	Brake Lining Rivet (14) . . . . .	215-156	215-156
79	Brake Band Long Rivet (4) . . . . .	T06-66	T06-66
80	Brake Band Short Rivet (4). . . . .	DU-578A	DU-578A
81	Brake Screw. . . . .	DU-572	DU-572
79	Brake Band Long Rivet (4) . . . . .	T06-66	T06-66
82	Brake Band Pin. . . . .	DU-579	DU-579
*	Brake Band Pin Cotter (1/8" x 1-1/4") . . . . .	D02-330	D02-330
83	Brake Lever . . . . .	DU-570	DU-570
84	Brake Lever Cotter (3/16" x 2") . . . . .	D02-438	D02-438
85	Brake Screw Nut. . . . .	DU-573	DU-573
86	Brake Screw Guide . . . . .	DU-594	DU-594
87	Brake Screw Guide Cotter (3/16" x 2"). . . . .	D02-438	D02-438
	Clutch Lever Assembly. . . . .	DU-A565	DU-A565
88	Clutch Lever. . . . .	DU-565	DU-565
89	Clutch Latch Pin. . . . .	DU-571	DU-571
90	Clutch Latch . . . . .	DU-566	DU-566
91	Clutch Latch Spring. . . . .	DU-567	DU-567
*	Motor Nameplate . . . . .	C04-301	C04-301
*	Motor Nameplate Screw (4). . . . .	R4K-302	R4K-302

\* Not illustrated.



## BASE AND ROPE DRUM PARTS

PART NUMBER FOR ORDERING

		↓	↓	↓	↓
		D6U	D6UL	EU, EUL,	EUA, EUAL
92	Base . . . . .	EU-564A	EUL-A677B	EU-564A	EUL-A677B
93	Dowel Pin . . . . .	D02-347	D02-347	D02-347	D02-347
94	Grease Plug . . . . .	22SR-165	22SR-165	22SR-165	22SR-165
95	Base Bolt (2) . . . . .	-----	EU-775	-----	EU-775
96	Base Bolt Nut (2) . . . . .	-----	DU-562	-----	DU-562
97	Base Bolt Lock Washer (4) . . . . .	-----	D01-692	-----	D01-692
98	Base Cap Screw . . . . .	-----	EU-778	-----	EU-778
99	Hub Bushing . . . . .	-----	EU-678	-----	EU-678
100	Grease Fitting . . . . .	-----	23-188	-----	23-188
*	Clutch Engagement Plate . . . . .	EU-94	EU-94	EU-94	EU-94
*	Engagement Plate Screws (3) . . . . .	R4K-302	R4K-302	R4K-302	R4K-302
101	Extension Hub . . . . .	-----	EU-676	-----	EU-676
102	Hub Cap Screw (for Winches over Serial 42,500) (4) . . . . .	-----	23-717	-----	23-717
*	Hub Stud (4) (for Winches under Serial 42,500) . . . . .	-----	EU-679	-----	EU-679
*	Hub Stud Nut (4) (for Winches under Serial 42,500) . . . . .	-----	D02-418	-----	D02-418
104	Clutch Eccentric for D6U, D6UL, EU and EUL . . . . .	DU-585A	DU-585A	DU-585A	DU-585A
	for EUA and EUAL . . . . .	-----	-----	EUA-585A	EUA-585A
105	Clutch Eccentric Bearing . . . . .	T03-33	T03-33	T03-33	T03-33
106	Clutch Eccentric Spacer (not used on EUA or EUAL) . . . . .	DU-599	DU-599	EU-599	EU-599
107	Spool Type Drum . . . . .	EU-324	-----	EU-324	-----
108	Rope Set Screw (2) . . . . .	DU-381	-----	DU-381	-----
109	Rope Drum . . . . .	-----	EU-684	-----	EU-684
110	Rope Set Screw (2) . . . . .	-----	DU-381	-----	DU-381
111	Rope Drum Cover . . . . .	DU-580	-----	DU-580	-----
112	Grease Fitting . . . . .	23-188	-----	23-188	-----
113	Drum Cover Screw (4) . . . . .	D02-506	-----	D02-312	-----
114	Motor Case Cover Screw (3) . . . . .	D02-506	D02-506	D02-312	D02-312
*	Winch Head . . . . .	DU-606	-----	DU-606	-----
*	Extra Capacity Rope Drum (for D6U and EUA only) . . . . .	DU-688	-----	DU-688	-----
*	Rope Set Screw (2) . . . . .	DU-381	-----	DU-381	-----
*	Winch Nameplate . . . . .	EU-301	EU-301	EU-301	EU-301
*	Winch Nameplate Screw (4) . . . . .	R4K-302	R4K-302	R4K-302	R4K-302
*	Caution Tag . . . . .	TA-147A	TA-147A	TA-147A	TA-147A
*	Caution Tag Screw (4) . . . . .	D02-302	D02-302	D02-302	D02-302

\* Not illustrated.

## ACCESSORIES

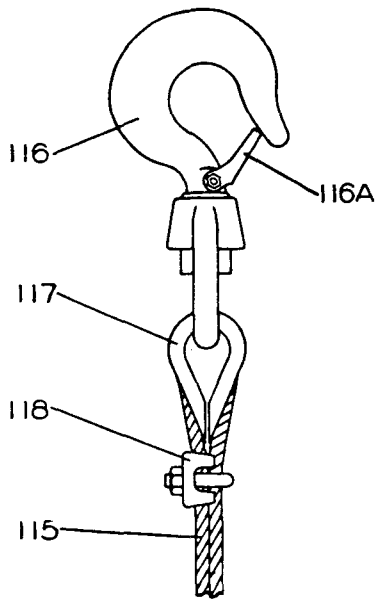

**Wire Rope Assembly**

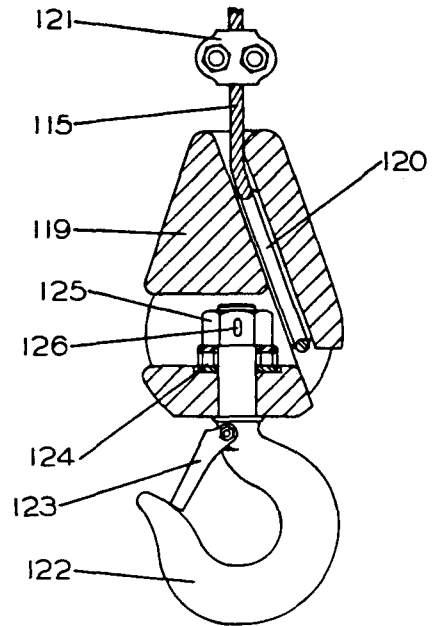

**Hook Block Assembly**

(Dwg. TPC452)

PART NUMBER FOR ORDERING

115	Wire Rope (specify length)	
	5/16" dia. ....	DU-372
	3/8" dia. ....	EU-372
	Swivel Hook and Fittings Assembly	
	for 5/16" dia. Wire Rope ....	DU-AS601
	for 3/8" dia. Wire Rope ....	EU-AS601
116	Swivel Hook. ....	D01C-S377
116A	Hook Latch Kit (individual parts not sold separately). ....	D01-S4055
117	Rope Thimble	
	for 5/16" dia. Wire Rope ....	DU-602
	for 3/8" dia. Wire Rope ....	D10-721
118	Rope Clamp (3)	
	for 5/16" dia. Wire Rope ....	DU-375
	for 3/8" dia. Wire Rope ....	D04-464
	Hook Block Assembly ....	DU-AS463A
119	Hook Block ....	D02-463A
120	Wire Rope Wedge ....	D02-373
121	Wire Rope Clamp ....	D04-464
122	Hook ....	D02-S377
123	Hook Latch Kit (individual parts not sold separately). ....	D02-S123
124	Hook Bearing (Timken T-76 or its equivalent). ....	D02-379A
125	Hook Nut ....	D02-305B
126	Roll Pin. ....	20QDM-330
*	Exhaust Muffler ....	D02-674A
*	Muffler Nipple ....	P35-286
*	Muffler Chain. ....	D02-673
*	S-Hook ....	D02-421

\* Not illustrated.

**REMOTE CONTROL FOR  
SIZES D6U, D6UL, EU, EUL, EUA AND EUAL  
OVER SERIAL 5,000**

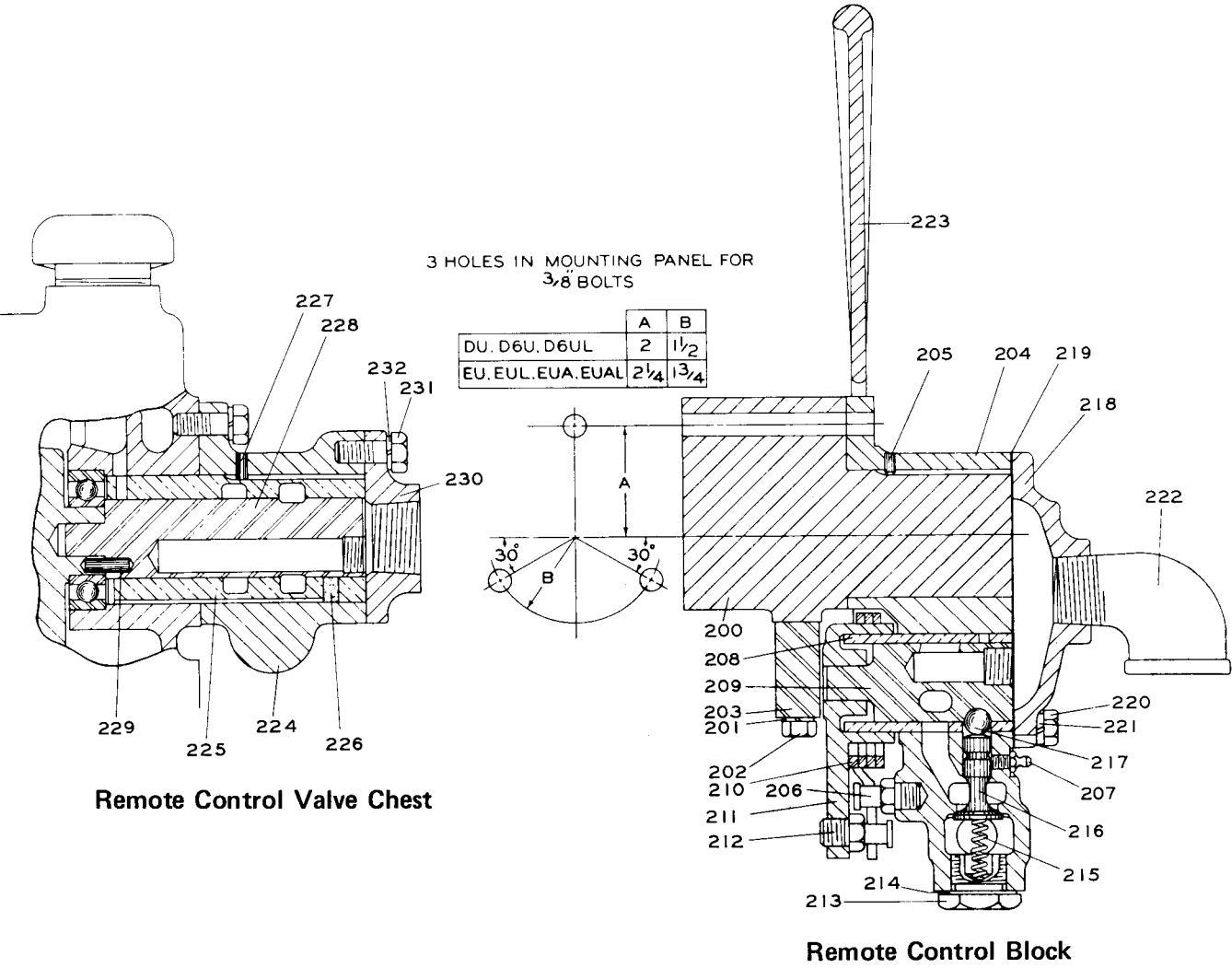

(Dwg. TPB43)

## REMOTE CONTROL PARTS

PART NUMBER FOR ORDERING

		D6U D6UL	EU, EUL, EUA, EUAL
	Remote Control Block Assembly		
	for Winch without Automatic Brake . . . . .	DU-A685	EU-A685
	for Winch with Automatic Brake . . . . .	D02-A685	D10-A685
200	Remote Control Block . . . . .	D02-685	D10-685
201	5/16" Lock Washer (2). . . . .	T11-58	T11-58
202	Control Arm Retainer Screw (2). . . . .	G7-7A	G7-7A
203	Control Arm Retainer . . . . .	D02-687	D02-687
*	Reducing Bushing (2) (1" to 3/4"). . . . .	C10-284	
204	Control Block Valve Chest . . . . .	D02-876A	D10-876A
*	Grease Fitting (2) . . . . .	-----	23-188
*	Brake Inlet Plug (not used on Winches with Automatic Brake). . . . .	TC-368	D02-402
205	Bushings Key (2) . . . . .	D02-538	B12-255
*	Valve Oiler. . . . .	JA4-75	JA4-75
206	Throttle Spring Stop Pin. . . . .	D02-553	D02-553
207	Valve Chest Grease Fitting . . . . .	R1-188	R1-188
208	Control Block Reverse Valve Bushing . . . . .	D02-945S	D10-945-5S
*	Air Inlet Plug . . . . .	-----	22SR-165
209	Control Block Reverse Valve		
	for Winch without Automatic Brake . . . . .	DU-944	EU-944
	for Winch with Automatic Brake . . . . .	D02-944	D10-944
210	Control Block Throttle Lever Spring. . . . .	D02-412B	D02-412B
211	Control Block Throttle Arm . . . . .	D02-555	D10-555
212	Throttle Spring Stop Pin. . . . .	D02-553	D02-553
213	Control Block Throttle Valve Cap. . . . .	D02-943	D02-943
214	Control Block Throttle Valve Cap Gasket. . . . .	G601-411	G601-411
215	Control Block Throttle Valve Spring. . . . .	B01-11	B01-11
216	Control Block Poppet Throttle Valve . . . . .	D02-940	D02-940
217	Control Block Throttle Valve Ball. . . . .	D10-280	D10-280
218	Control Block Valve Chest Cover . . . . .	D02-546A	D10-546A
219	Control Block Valve Chest Cover Gasket . . . . .	D02-928	D10-928
220	Control Block Valve Chest Cover Screw (2) . . . . .	D02-506	D02-506
221	Valve Chest Screw Lock Washer (2) . . . . .	D02-321	D02-321
222	Exhaust Elbow . . . . .	DU-587	DU-587
223	Control Block Throttle Lever. . . . .	EU-556	EU-556
*	Throttle Lever Bolt (2). . . . .	D02-411A	D02-411A
*	Throttle Lever Bolt Nut (2). . . . .	D02-418A	D02-418A
	Remote Control Valve Chest Assembly . . . . .	D02-A686	D10-A686
224	Remote Control Valve Chest . . . . .	C04-545	C10-545
225	Rotary Valve Bushing. . . . .	D02-525AS	D10-525AS
226	Valve Oiler. . . . .	JA4-75	JA4-75
227	Bushings Key. . . . .	D02-538	B12-255
228	Rotary Valve . . . . .	D02-526	D10-526
229	Valve Drive Pin. . . . .	D02-527	D10-527
230	Remote Control Valve Chest Cover. . . . .	C04-546	C10-546
*	Valve Chest Long Screw (2). . . . .	D02-548	D10-548
231	Valve Chest Short Screw (2) . . . . .	D02-506	D02-506
232	3/8" Lock Washer (4). . . . .	D02-321	D02-321
	<b>Remote Control Conversion Unit</b> (for converting Winch from standard Throttle to Remote Control) (includes illustrated parts 200, 201 (2), 202 (2), 203, 220 (2), 221 (2), 224, 225, 226, 227, 228, 229, 230, 231 (2) and (4) 232; also includes non-illustrated parts C10-284 (2) and (2) D02-548 for Sizes DU, D6U and D6UL; D10-548 (2) for Sizes EU, EUA, EUL and EUAL). . . . .	DU-C685	EU-C685

\* Not illustrated.

## AUTOMATIC BRAKE FOR D6U, D6UL, EU, EUL, EUA and EUAL

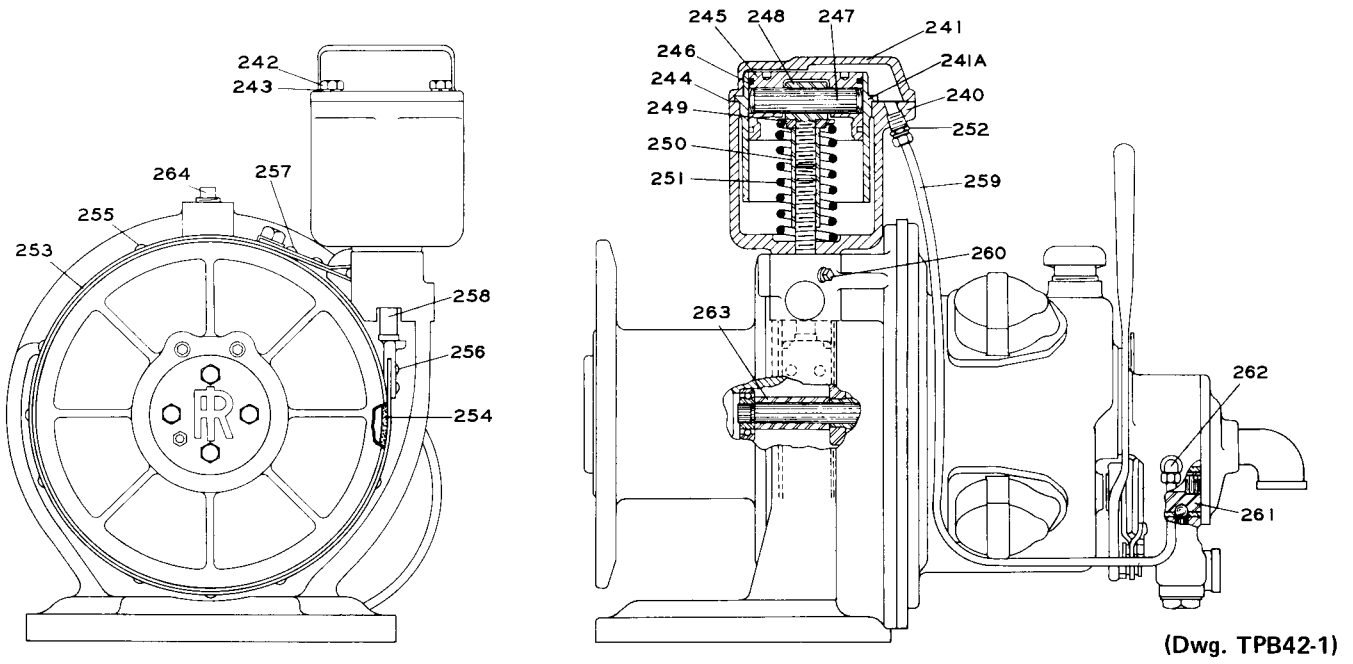

(Dwg. TPB42-1)

PART NUMBER FOR ORDERING

	Brake Cylinder Case Assembly . . . . .	DU-A709
240	Brake Cylinder Case . . . . .	DU-709
	Brake Cylinder Assembly . . . . .	HH5D-A505A
241	Cylinder Head . . . . .	HH5D-H505A
241 A	Cylinder Sleeve . . . . .	HH5D-L505A
242	Brake Cylinder Cap Screw (4) . . . . .	D10-354
243	Brake Cylinder Cap Screw Washer (copper) (4) . . . . .	HU-504
244	Brake Cylinder Gasket . . . . .	HU-507
245	Brake Piston Assembly . . . . .	DU-A713B
246	Brake Piston Ring . . . . .	HU-337
247	Brake Piston Wrist Pin . . . . .	HU-514A
248	Brake Trunnion . . . . .	DU-702
249	Brake Spring Washer . . . . .	DU-703
250	Brake Screw Coupling . . . . .	DU-708
251	Brake Spring . . . . .	DU-710
252	Brake Pipe Connection . . . . .	DU-711
	Brake Band Assembly . . . . .	DU-B574
253	Brake Band . . . . .	DU-574
254	Brake Lining . . . . .	DU-575
255	Brake Lining Rivet (14) . . . . .	215-156
256	Brake Band Long Rivet (4) . . . . .	T06-66
257	Brake Band Short Rivet (4) . . . . .	DU-578A
258	Automatic Brake Adjusting Screw . . . . .	207-158
256	Brake Band Long Rivet (4) . . . . .	T06-66
259	Brake Pipe . . . . .	
	for D6U and D6UL . . . . .	DU-401
	for EU, EUA, EUL and EUAL . . . . .	EU-401
260	Brake Cylinder Case Set Screw . . . . .	HU-867
261	Automatic Brake Reverse Valve . . . . .	
	for D6U and D6UL . . . . .	D02-944
	for EU, EUA, EUL and EUAL . . . . .	D10-944
262	Brake Pipe Elbow . . . . .	
	for D6U and D6UL . . . . .	D02-400
	for EU, EUA, EUL and EUAL . . . . .	D10-400
263	Clutch Jaw Spacer . . . . .	DU-712
264	1/2" Pipe Plug . . . . .	D02-351

## COLUMN CLAMP CONE FOR D6U

**PART NUMBER FOR ORDERING**

	Column Clamp Cone Assembly . . . . .	DU-A619
270	Column Clamp Cone . . . . .	DU-619
271	Column Clamp Cone Bolt (4). . . . .	EU-775
272	Column Clamp Cone Bolt Nut (4). . . . .	DU-562
273	Column Clamp Cone Bolt Lock Washer (4)	DOI-692

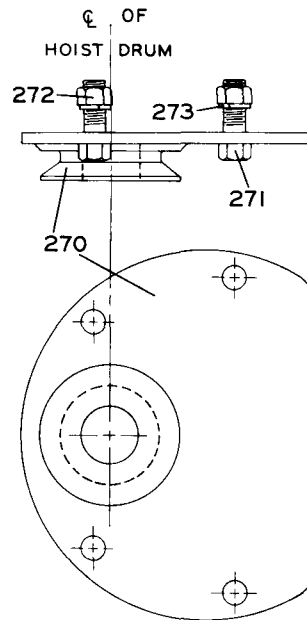

(Dwg. TPB177A)

## POLE MOUNTING FOR D6U and EUA

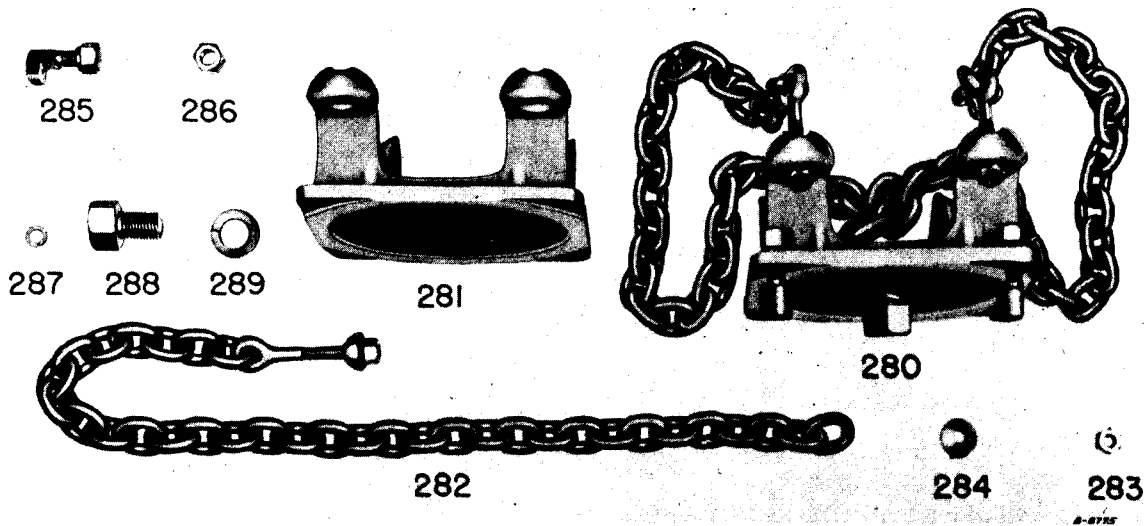

**PART NUMBER FOR ORDERING**

	Pole Mounting Assembly. . . . .	DU-A622
281	Pole Mounting Saddle. . . . .	DU-622
282	Pole Mounting Chain (2). . . . .	DU-623
283	Eye Bolt Nut (2). . . . .	HU-776
284	Eye Bolt Washer (2). . . . .	DU-626
285	Base Clamp Bolt (2). . . . .	DU-561
286	Base Clamp Bolt Nut (2). . . . .	DU-562
287	Base Clamp Bolt Lock Washer (2). . . . .	DU-563
288	Base Swivel Bolt . . . . .	DU-597
289	Base Swivel Bolt Lock Washer . . . . .	DU-598

COLUMN MOUNTING FOR D6U, EU and EUA

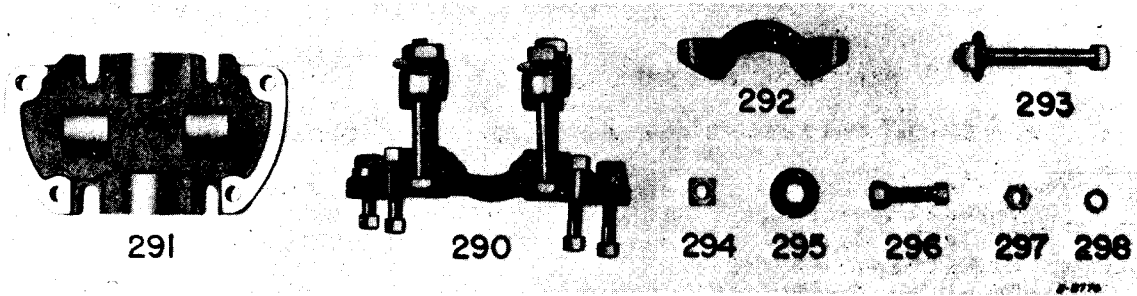

PART NUMBER FOR ORDERING

290	Column Mounting Assembly . . . . .	DU-A621
291	Column Mounting . . . . .	DU-621
292	Column Clamp (2) . . . . .	DU-657
293	Column Clamp Bolt (4) . . . . .	DU-658
294	Column Clamp Bolt Nut (1 for each Bolt) . . . . .	DU-659
295	Column Clamp Bolt Washer (1 for each Bolt) . . . . .	DU-660
296	Column Mounting Bolt (4) . . . . .	241-708
297	Column Mounting Bolt Nut (1 for each Bolt) . . . . .	DU-562
298	Column Mounting Bolt Lock Washer (1 for each Bolt) . . . . .	DU-563

# PULL CHAIN THROTTLE

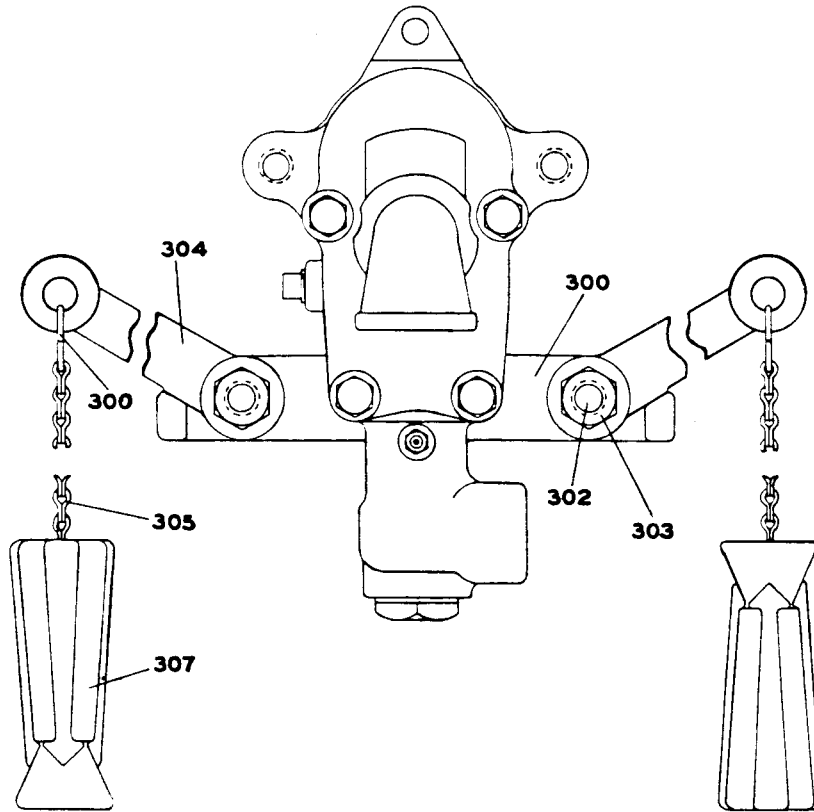

(Dwg. TPB333)

PART NUMBER FOR ORDERING

300	Throttle Control Arm for D6U and D6UL . . . . .	D02-555
	for EU, EUA, EUL and EUAL . . . . .	D10-555
*	Throttle Spring Stop Pin . . . . .	D02-553
302	Throttle Lever Bolt (2) . . . . .	D02-411A
303	Throttle Lever Bolt Nut (2) . . . . .	D02-418A
304	Pull Chain Throttle Lever (2) . . . . .	D02-556
305	Throttle Lever Chain (2) (specify length) . . . . .	DU-413
306	S-Hook (4) . . . . .	D02-421
307	Throttle Handle (2) . . . . .	MR-415

\* Not illustrated.



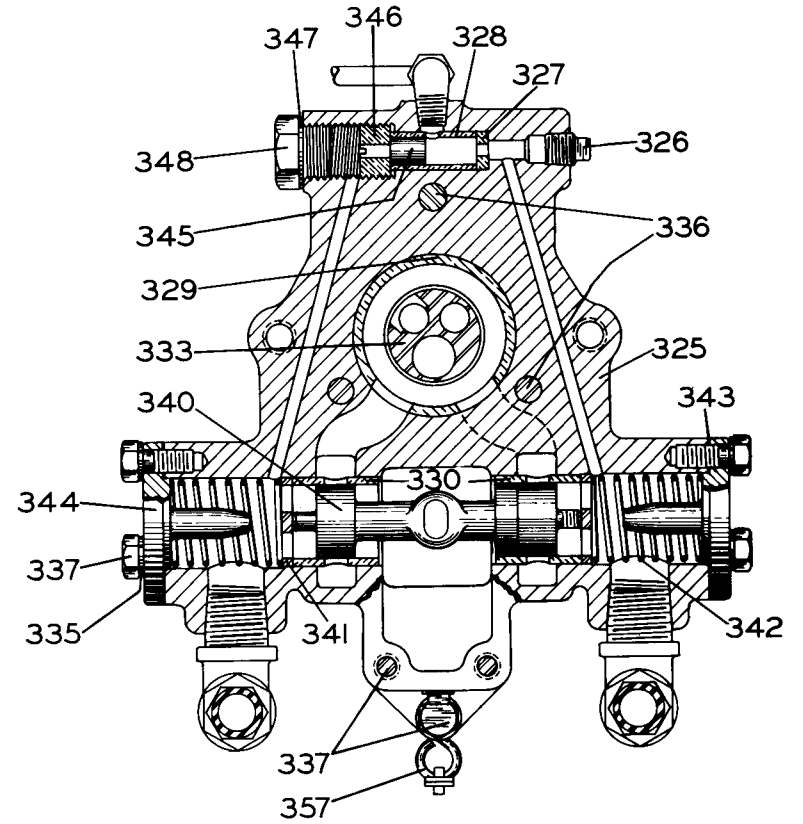
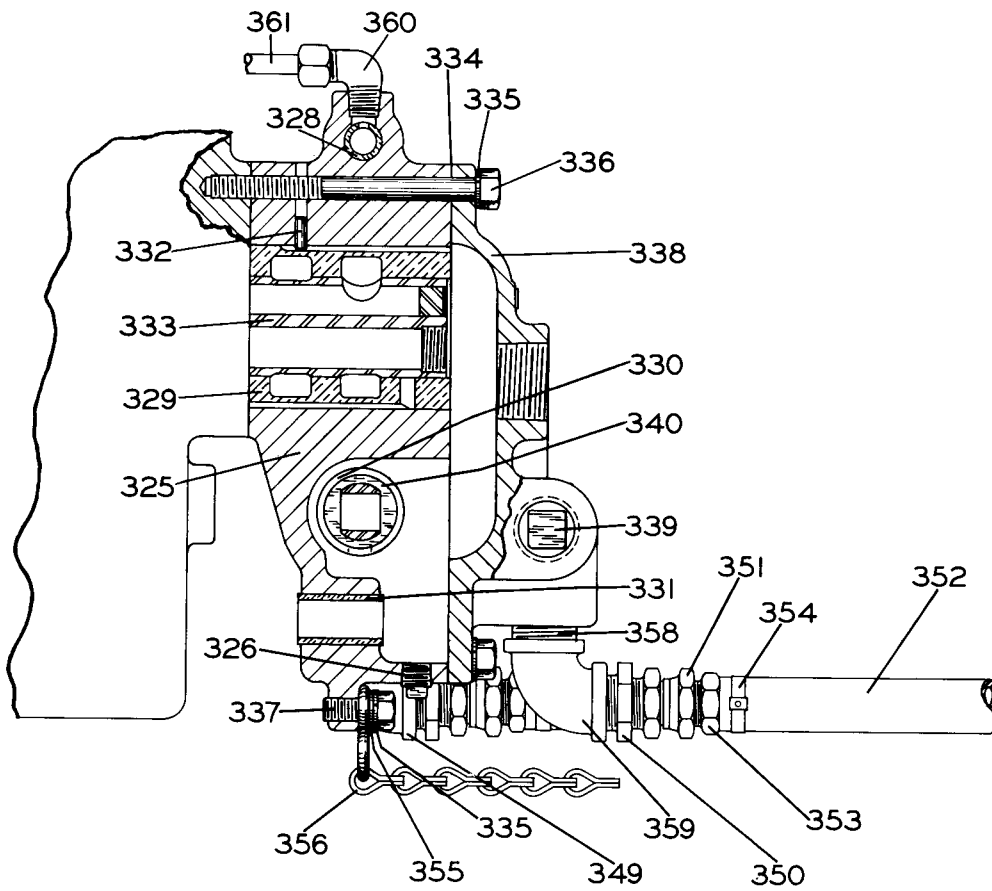

(Dwg. TPA916)

Shuttle Valve Chest Assembly for EU Winch

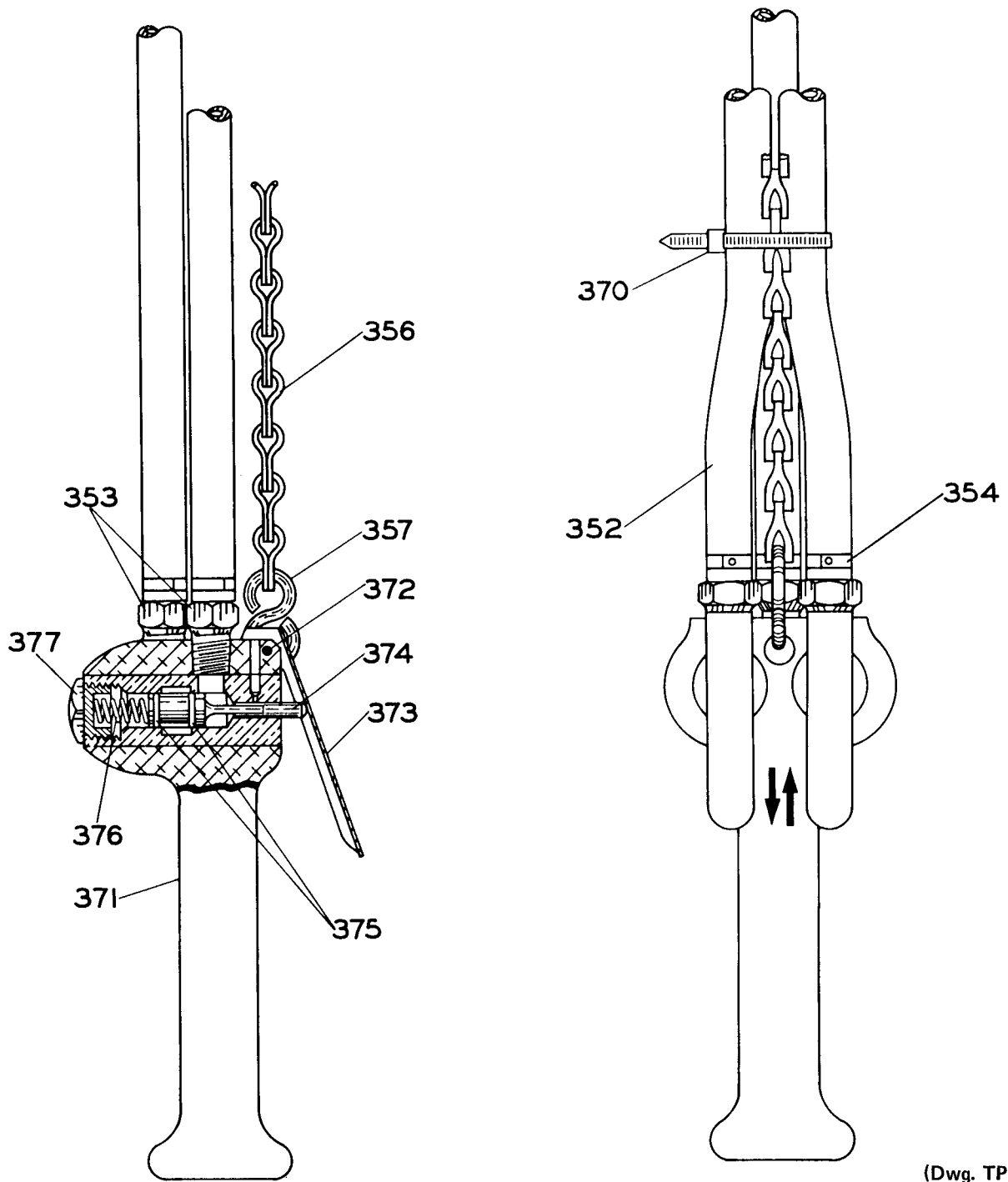

(Dwg. TPB710)

MR-269 Pendent Throttle Handle Assembly

	Valve Chest Assembly . . . . .	EU-A245
325	Shuttle Valve Chest . . . . .	D10-245
326	1/4" Pipe Plug (2) . . . . .	D02-402
327	Brake Valve Disc . . . . .	D10-44
328	Brake Valve Bushing . . . . .	D10-63
329	Rotary Valve Bushing . . . . .	D10-525A
*	Valve Oiler . . . . .	JA4-75
330	Shuttle Valve Bushing (2) . . . . .	D10-247
331	Stop Arm Shaft Bushing . . . . .	D10-243
332	Rotary Valve Bushing Key . . . . .	R0AJ-191
333	Rotary Valve . . . . .	D10-526
*	Valve Drive Pin . . . . .	D10-527
334	Valve Chest Cover Gasket . . . . .	D10-236
335	3/8" Lock Washer (12) . . . . .	D20-321
336	Valve Chest Long Screw (3) . . . . .	D10-548
337	Valve Chest Short Screw (9) . . . . .	D02-506
338	Shuttle Valve Chest Cover . . . . .	D10-241
339	Valve Chest Cover Plug . . . . .	22SR-165
340	Shuttle Valve . . . . .	D10-246
341	Shuttle Valve Washer (2) . . . . .	D10-248
342	Shuttle Valve Spring (2) . . . . .	D10-250
343	Shuttle Valve Cap Gasket (2) . . . . .	D10-239
344	Shuttle Valve Cap (2) . . . . .	D10-238
345	Brake Valve . . . . .	D10-62
346	Brake Valve Seat . . . . .	D10-65
347	Brake Valve Cap Gasket . . . . .	D01-946
348	Brake Valve Cap . . . . .	D01-943
*	Exhaust Elbow . . . . .	DU-587
349	Street Elbow (2) . . . . .	DU-581
350	Bushing (3) . . . . .	HEK3-284
351	Hose Union (3) . . . . .	MR-129
352	Control Hose (3)	
	15 ft. length . . . . .	H6A-15
	length as specified . . . . .	BH6A
353	Hose Nipple (2 for each Hose) . . . . .	RV1-46
354	Hose Clamp (2 for each Hose) . . . . .	B-1
355	3/8" Plain Washer . . . . .	D02-419
356	Pendent Throttle Chain	
	15 ft. length . . . . .	D02-413-15
	length as specified (order Chain 1" shorter than (352) Control Hose) . . . . .	D02-B413
357	S-Hook (2) . . . . .	D01-221
358	Supply Nipple . . . . .	D02-456
359	Supply Elbow . . . . .	P25-198
360	Brake Pipe Elbow . . . . .	D10-400
361	Brake Pipe . . . . .	D02-401A-1
371	Pendent Throttle Handle Assembly . . . . .	MR-269
372	Throttle Lever Pin . . . . .	DLC-120
373	Pendent Throttle Lever (2) . . . . .	R00H-273A
*	Lever Pin Screw (2) . . . . .	R2FA-662
*	Lever Pin Screw Washer (2) . . . . .	D02-138
374	Pendent Throttle Valve (2) . . . . .	MR-264
375	Pendent Throttle Valve Seal Ring (2 for each Valve) . . . . .	AF120-289
376	Pendent Throttle Valve Spring (2) . . . . .	D01-51
377	Pendent Throttle Valve Cap (2) . . . . .	D02-180

\* Not illustrated.

## DRUM GUARDS

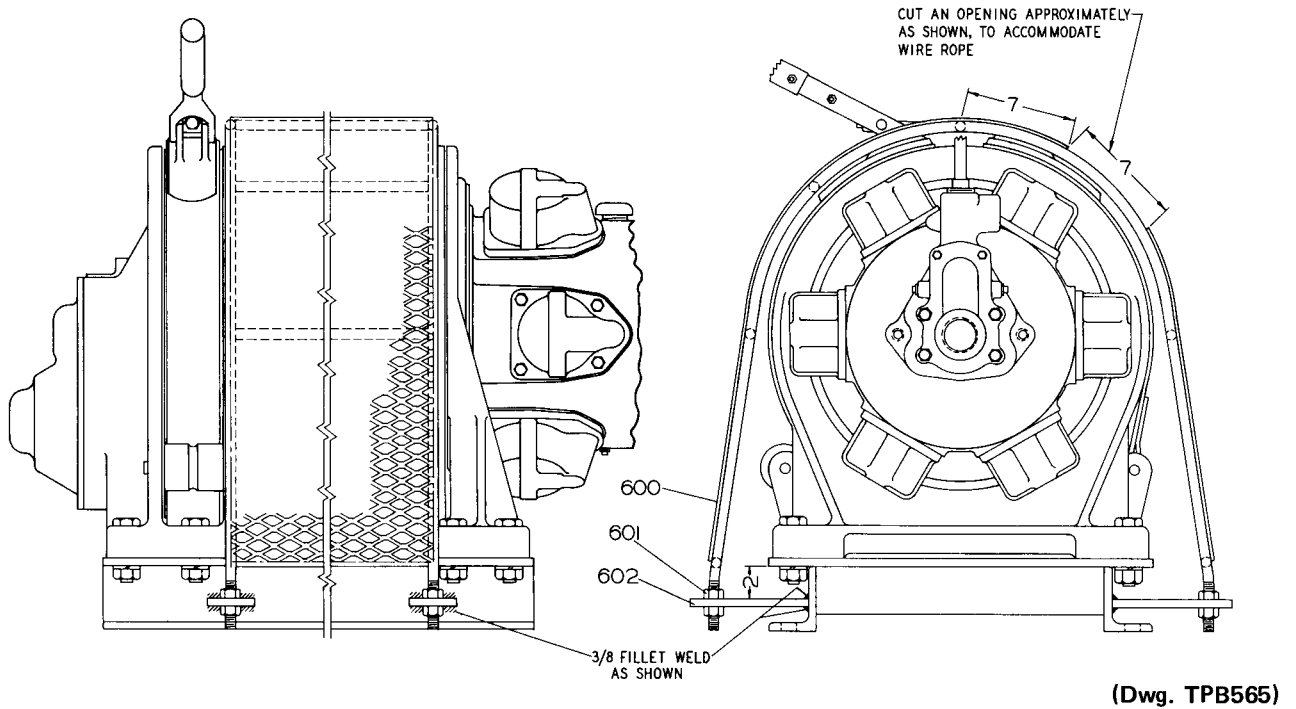

PART NUMBER FOR ORDERING

600	Drum Guard for D6U, EU, EUA . . . . .	EU-298
	for D6UL, EUL, EUAL . . . . .	EUL-298
601	5/8"-11 thd Nut (8) . . . . .	K6U-8
602	Plate (4) . . . . .	K6U-299

## AIR STRAINER

PART NUMBER FOR ORDERING

661	Air Strainer Assembly . . . . .	EU-A267
662	Air Strainer Screen . . . . .	P25-61A
663	Air Strainer Cap . . . . .	P25-268
664	Air Strainer Plug . . . . .	P25-536
*	Air Strainer Nipple (required for attaching Strainer to Winch) . . . . .	D02-456

\* Not illustrated.

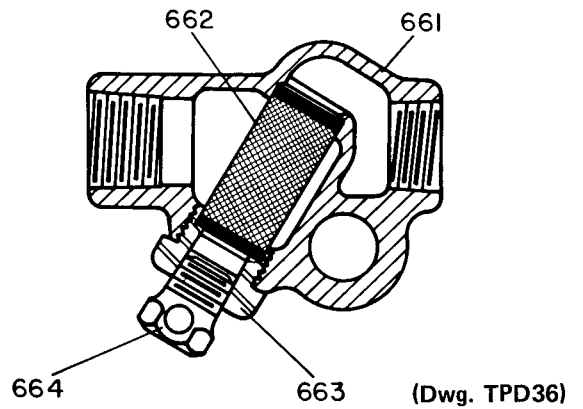

## STANDARD HARDWARE ITEMS

ILLUSTRATION NUMBER (Do not use for ordering)	PART NUMBER FOR ORDERING	DESCRIPTION
6	TC-368	1/8" Steel Pipe Plug
6	D02-402	1/4" Steel Pipe Plug
26	D02-548	3/8"-16 x 3-3/4" long hex head Cap Screw
27	D02-506	3/8"-16 x 7/8" long hex head Cap Screw
28	D02-321	3/8" ASA Light Lock Washer
35	D02-541	3/16" x 1" long countersunk Head Rivet
35	D06-541	3/16" x 1-1/2" long countersunk Head Rivet
35	D06-554	1/4" x 1-1/2" long countersunk Head Rivet
47	D02-506	3/8"-16 x 7/8" long hex head Cap Screw
47	D10-506	7/16"-14 x 1" long hex head Cap Screw
48	D02-504	1/32" thick Copper Washer
56	D02-418A	1/2"-13 hex Jam Nut
59	D02-312	3/8"-16 x 1-3/8" long hex head Cap Screw
60	D02-506	3/8"-16 x 7/8" long hex head Cap Screw
60	D02-312	3/8"-16 x 1-3/8" long hex head Cap Screw
78	215-156	.146" diameter x 5/16" long countersunk head Rivet
79	T06-66	3/16" diameter x 5/8" long countersunk head Rivet
80	DU-578	3/16" diameter x 3/8" long oval head Soft Iron Rivet
95	EU-775	3/4"-10 x 2-1/4" long bolt
96	DU-562	3/4"-10 Finished Hex Nut
97	D01-692	3/4"-10 Positive ASA Light Lock Washer
98	EU-778	3/4"-10 x 1" long hex head Cap Screw
101	23-188	Alemite No. 1610-B, 1/8" P.T. x 11/16" long
103	D02-418	3/8"-16 Finished Hex Nut
112	23-188	Alemite No. 1610-B, 1/8" P.T. x 11/16" long
113	D02-506	3/8"-16 x 7/8" long hex head Cap Screw
113	D02-312	3/8"-16 x 1-3/8" long hex head Cap Screw
114	D02-506	3/8"-16 x 7/8" long hex head Cap Screw
114	D02-312	3/8"-16 x 1-3/8" long hex head Cap Screw
*	DU-381	1/2"-13 x 1-1/4" long Socket Set Screw
124	20QDM-330	5/32" x 1-1/4" long Rollpin
202	G7-7A	5/16"-18 x 2-1/4" long hex head Cap Screw
*	23-188	Alemite No. 1610-B, 1/8" P.T. x 11/16" long
207	R1-188	Alemite No. 1641-B, 1/4"-28 x 35/64" long
220	D02-506	3/8"-16 x 7/8" long hex head Cap Screw
221	D02-321	3/8" ASA Light Lock Washer
*	D02-418A	1/2"-13 hex Jam Nut
231	D02-506	3/8"-16 x 7/8" long hex head Cap Screw
242	D10-354	1/2"-13 x 2-3/4" long hex head Cap Screw Zinc Plated
255	215-156	0.146" diameter x 5/16" long countersunk head Rivet
256	T06-66	3/16" diameter x 5/8" long countersunk head Rivet
260	HU-867	1/2"-13 x 5/8" long Cup Point Safety Set Screw
271	EU-775	3/4"-10 x 2-1/4" long Bolt
272	DU-562	3/4"-10 Finished Hex Nut
273	D01-692	3/4" Positive ASA Light Lock Washer
283	HU-776	5/8"-11 Finished Hex Nut
286	DU-562	3/4"-10 Finished Hex Nut
287	DU-563	3/4" ASA Light Lock Washer
288	DU-597	1-1/4"-7 x 2" long hex head Cap Screw
289	DU-598	1-1/4" ASA Light Lock Washer
293	DU-658	3/4"-10 x 6-1/2" long square head Machine Bolt
294	DU-659	3/4"-10 Standard Square Nut
295	DU-660	3/4" Flat Washer
296	241-708	3/4"-10 x 3" long hex head Cap Screw
297	DU-562	3/4"-10 Finished Hex Nut
298	DU-563	3/4" ASA Light Lock Washer
303	D02-418A	1/2"-13 hex Jam Nut

\* Not illustrated.

## MAINTENANCE INSTRUCTIONS

Remove the Throttle Valve Spring (19), Poppet Throttle Valve (17) and Throttle Valve Ball (18) from the Valve Chest (4) before attempting to withdraw the Reverse Valve (22) from the Reverse Valve Bushing (14).

The following procedure is recommended when replacement of the Rotary Valve Bushing (7) or Reverse Valve Bushing (14) is necessary.

1. Unscrew the Valve Chest Screws (26 and 27) and remove the Valve Chest Cover (23).
2. Screw a No. D02-932 Jack Bolt into each tapped lug on the Valve Chest (4) until the Jack Bolts contact the Motor Case (1). Turn each Jack Bolt a little at a time to jack the Valve Chest from the Motor Case.
3. Unscrew the Throttle Valve Cap (20) and remove the Spring (19), Poppet Throttle Valve (17) and Ball (18) from the Valve Chest (4).
4. Withdraw the Rotary Valve (15), Reverse Valve (22) and remove the Throttle Lever Spring (53).
5. Support the face of the Valve Chest (4) that contacts the Motor Case (1) and press out the old Bushings with an arbor **that will clear the Bushing Keys (11)**. **Caution:** Failure to use an arbor that will clear the Bushing Keys (11), or ejecting the Bushings from the cover side of the Valve Chest will destroy the Keys.
6. Support the face of the Valve Chest (4) that contacts the Valve Chest Cover (23). Align the keyslot in the new Reverse Valve Bushing with the Bushing Key (11), and press the Bushing into the Chest until the leading face of the Bushing is flush with the supported face of the Chest. Align the keyslot in the new Rotary Valve Bushing with the Bushing Key, and press the Bushing into the Chest until the bushing shoulder is flush with the supported face of the Chest.
7. Insert the No. 23470 Throttle Valve Stem Reamer or a 0.505" hand reamer through the throttle valve chamber in the Valve Chest and ream the hole through the wall of the new Reverse Valve Bushing.
8. Check the fit of the Rotary Valve (15) in the new Rotary Valve Bushing. If the Valve is tighter than a good running fit in the Bushing, lap in the Valve using a fine grain lapping compound whose abrasive agent will break up rapidly. Remove all trace of the compound with kerosene after obtaining the desired fit.
9. Check the fit of the Reverse Valve (22) in the new Reverse Valve Bushing. If the fit is too tight, ream the Bushing 1.375 dia. on Sizes DU, D6U and D6UL; 1.625 dia. on Sizes EU, EUA, EUL and EUAL. **Caution:** The Reverse Valve is chrome-plated; do not lap.
10. Rotate the Reverse Valve in the Reverse Valve Bushing until the arrows on the two parts are aligned and install the Throttle Valve Ball, Poppet Throttle Valve, Spring and Cap.
11. Install the Throttle Lever Spring (53) and Throttle Control Arm (52).
12. Align the holes through the Valve Chest (4) with those in the face of the Motor Case (1) and squarely start the protruding end of the Rotary Valve Bushing into the Case. Place a hardwood block on the chest face and press or drive in the Bushing until the Valve Chest contacts the Motor Case.

The two sections of the Crank (29) are matched before final machining, and the web of each section is stamped with an identification mark as AA17, CC21, XX19, etc. Only sections bearing identical marking can be used together. If more than one Crank is disassembled at one time, be sure only matched parts are assembled together.

Slide the Crank Pin Sleeve (30), plain end first, onto the crank pin.

Install the Connecting Rod Rings (37) so that the internally beveled ends are toward the Connecting Rods (36).

## AUTOMATIC BRAKE ADJUSTMENT

Remove the Brake Cylinder (241) and, using the No. R55R-26 Brake Adjusting Wrench, rotate the Brake Piston (245) until it projects 3/4" to 7/8" above the face of the Brake Cylinder Case (240).

## MAINTENANCE TOOLS

TOOL NUMBER FOR ORDERING	TOOL NAME FOR ORDERING	OPERATION
R55R-26	Brake Adjusting Wrench . . . . .	Rotating the Brake Piston (245) when making adjustment.
D02-426	Rope Set Screw Wrench . . . . .	Removing and installing the Rope Set Screws (108 and 110).
D02-932	Valve Chest Jack Bolt (2 required) . . . .	Removing the Valve Chest (4) from the Motor Case (1).
D06-933	Piston Ring Compressor (for D6U and D6UL)	Compressing the Piston Rings (42 and 43) in the groove of the Pistons (41) for installation of the Cylinder (45).
D10-933	Piston Ring Compressor (for EU, EUA, EUL and EUAL)	
23468	Throttle Valve Seat Reamer . . . . .	Refacing the Throttle Valve Seat in the Valve Chest (4).
23470	Throttle Valve Stem Reamer . . . . .	Reaming the hole in the Reverse Valve Bushing (14) for the Throttle Valve Ball (18).

