

OPERATION AND MAINTENANCE MANUAL for BEEBE

MODEL VL150
15 TON MANUAL CHAIN HOIST

MODEL VL200
20 TON MANUAL CHAIN HOIST

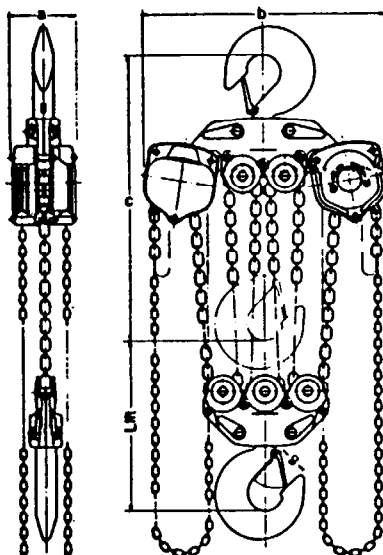

WARNING:

Do not use this hoist for lifting, supporting, or transporting people or lifting or supporting loads over people.

Always operate, inspect and maintain this Hoist in accordance with American National Standards Institute Safety Code (ANSI B30.16) and any other applicable safety codes and regulations.

Read all the enclosed instructions and warning labels before installing, operating or repairing this hoist.

SAFETY SUMMARY

WARNING: Do not use this hoist for lifting, supporting, or transporting people or lifting or supporting loads over people.

WARNING: The supporting structures and load-attaching devices used in conjunction with this hoist must provide an adequate safety factor to handle the rated load, plus the weight of the hoist. If in doubt, consult a qualified structural engineer.

The National Safety Council, Accident Prevention Manual for Industrial Operations, Eighth Edition and other recognized safety sources make a common point: Employees who work near cranes or assist in hooking on or arranging a load should be instructed to keep out from under the load. From a safety standpoint, one factor is paramount: conduct all lifting operations in such a manner that if there were an equipment failure, no personnel would be injured. This means keep out from under a raised load and keep out of the line of force of any load.

To the best of our knowledge, INGERSOLL-RAND Material Handling Products hoists are manufactured in accordance with the latest standards in effect at time of manufacture.

However, contrary to common belief, the Occupational Safety and Health Act of 1970, as we understand it, generally places the burden of compliance with the user, not the manufacturer. Many OSHA requirements are not concerned or connected with the manufactured product but are, rather, connected with the final installation: "It is the owner's responsibility and user's responsibility to determine the suitability of a product for any particular use. Check all applicable industry, trade association, federal, state and local regulations. Read all operating instructions and warnings before operation."

Rigging: It is the responsibility of the operator to exercise caution, use common sense and be familiar with proper rigging techniques. See ANSI/ASME B30.9 for rigging information, American National Standards Institute, 1430 Broadway, New York, NY 10018.

NOTE: Using other than genuine INGERSOLL-RAND Material Handling Products parts will result in the void of warranty.

Hoists returned with opened, bent or twisted hooks; or without chain and hooks, will not be repaired or replaced under warranty.

SAFETY INSTRUCTIONS

1. Only allow qualified people (trained in safety and operation) to operate the hoist.
2. Only operate a hoist if you are physically fit.
3. When a "DO NOT OPERATE" sign is placed on the hoist controls, do not operate the hoist until the sign has been removed by designated personnel.
4. Before each shift, the operator should inspect the hoist for wear or damage.
5. Never use a hoist which inspection indicates is defective.
6. Periodically, inspect the hoist thoroughly and replace worn or damaged parts.
7. Lubricate the hoist regularly.
8. Do not use hoist if safety latch on a hook has been sprung or broken.
9. Check that the safety latches are engaged before using.
10. Never splice a hoist chain by inserting a bolt between links.
11. Only lift loads less than or equal to the rated capacity of the hoist. See warning labels attached to the hoist.
12. Never use the hoist chain as a sling.
13. Never operate a hoist when the load chain is not centered under the hook. Do not "side pull" or "yard."
14. Never operate a hoist with twisted, kinked, "capsized" or damaged load chain.
15. Do not force a chain or hook into place by hammering.
16. Never insert the point of the hook into a chain link.
17. Be certain the load is properly seated in the saddle of the hook.
18. Do not support the load on the tip of the hook.
19. Never run the load chain over a sharp edge. Use a sheave.
20. When using two hoists to suspend one load, select two hoists both of which have rated capacities equal to or more than the load to be lifted. This provides adequate safety in the event of a sudden load shift or failure of one hoist.
21. Pay attention to the load at all times when operating the hoist.
22. Always ensure that you, and all other people, are clear of the path of the load. Do not lift a load over people.
23. Never use the hoist for lifting or lowering people, and never allow anyone to stand on a suspended load.
24. Ease the slack out of the chain and sling when starting a lift. Do not jerk the load.
25. Do not swing a suspended load.
26. Never suspend a load for an extended period of time.
27. Never leave a suspended load unattended.
28. Never weld or cut a load suspended by the hoist.
29. Never use the hoist chain as a welding electrode.
30. Do not operate hoist if chain jumping, excessive noise, jamming, overloading, or binding occurs.
31. Keep the load from hitting the load chain.
32. Only operate the hoist with manual power.
33. After use, properly secure hoist and loads.

PARTS ORDERING INFORMATION

The use of replacement parts other than INGERSOLL-RAND Material Handling Products will invalidate the Company's warranty. For prompt service and genuine INGERSOLL-RAND Material Handling Products parts, provide your nearest Distributor with the following:

1. Complete model number as it appears on the nameplate: VL150 or VL200.
2. Part number and part name as shown in manual.
3. Quantity required.

DESCRIPTION

The VL150 and VL200 both use two manual 2-1/2 hoist units to lift a load. The number of chain falls determines the load that can be lifted. For the VL150, six fall times 2-1/2 tons equals 15 tons of load. For the VL200, eight times 2-1/2 tons equals 20 tons of load.

One hoist unit is connected to each end of a top hook assembly. Each hoist unit has its own hand chain. The single load chain is reeved through the top hook idler sheaves and the bottom hook idler sheaves. The ends of the load chain are anchored to the hoist bodies.

OPERATION

To keep the load chain centered in the block assemblies, operate both hoist units, at approximately the same speed. For quick operation, use two operators. If one operator is used, he should operate each hoist a little at a time.

When facing the hand chain side of the hoist:

Rotate hand chain clockwise to raise load.

Rotate hand chain counterclockwise to lower load.

NOTE: The clicking sound of the pawl on the ratchet gear is normal when a load is being raised.

INSPECTION

There are two types of inspection, the frequent inspection performed by the operator while using the hoist and periodic inspections performed by qualified personnel.

Frequent Inspection

On a hoist in continuous service, frequent inspection should be made at the beginning of each shift. In addition, visual inspections should be conducted during regular service for any damage or evidence of malfunction.

1. **OPERATION.** Check for visual or abnormal noises which could indicate a defect. Do not operate a hoist unless the chain feeds through the hoist and hook block smoothly. Listen for "clicking", binding or malfunctioning. If chain binds, jumps, or is excessively noisy, clean and lubricate the chain. If problem persists, replace the chain. Do not operate the hoist until all defects have been corrected. Check that hand chain moves freely and without binding or excessive drag. Hook should stop moving when hand chain stops moving.
2. **HOOKS.** Check for wear or damage, increase throat width, bent shank or bending of hook. Replace hooks with 15% increase in throat width or 10% bend. If the hook latch snaps past the tip of the hook, the hook is sprung and must be replaced. Check hook support bearings for lubrication and damage. Make sure that they swivel easily and smoothly. Repair or lubricate as necessary.

Model No.:	Throat Width	
	in.	(mm)
VL150	3.54	90
VL200	3.54	90

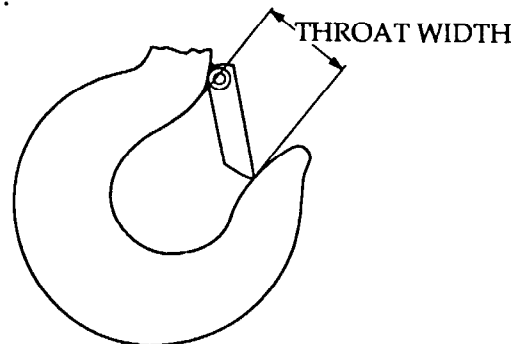

3. **HOOK LATCH.** Check operation of the safety latch. Replace if broken or missing.
4. **CHAIN.** Examine each of the links for bending, cracks in weld areas or shoulders, transverse nicks and gouges, weld splatter, corrosion pits, striation — minute parallel lines and chain wear, including bearing surfaces between chain links. Replace a chain that fails any of the inspections. Check lubrication and lubricate if necessary. See "Load Chain" under "LUBRICATION."

NOTE: Excessive wear or stretching may not be apparent from visual observation. Also inspect chain by measuring five links in accordance with instructions in "Periodic Inspection."

NOTE: A worn load chain may cause the load sheave to wear rapidly. Inspect the load sheave and replace if damaged or worn.

5. **CHAIN REEVING.** Ensure welds on standing links are away from load sheave. Re-install chain if necessary. Make sure chain is not capsized, twisted or kinked. Adjust as required.

Periodic Inspection

According to ANSI/ASME B30.16-1987, frequency of periodic inspection depends on the severity of usage: NORMAL, yearly; HEAVY, semiannually; SEVERE, quarterly. Disassembly may be required for HEAVY or SEVERE usage. Keep accumulative written records of periodic inspections to provide a basis for continuing evaluation.

Inspect all the items in a frequent inspection. Also inspect the following:

1. FASTENERS. Check rivets, cap screws, nuts, cotter pins and other fasteners on hook, hoist body and chain bucket, if used. Replace if missing and tighten if loose.
2. ALL COMPONENTS. Inspect for wear, damage, distortion, deformation and cleanliness. If external evidence indicates the need, disassemble. Check gears, shafts, bearings, sheaves, chain guides, springs and covers. Replace worn or damaged parts. Clean, lubricate and reassemble.
3. HOOK. Inspect hooks for cracks using magnetic particle or other suitable method. Remove cover and inspect hook retaining parts. Tighten or repair, if necessary.
4. CHAIN SHEAVES. Check for damage or excessive wear. Replace if necessary.
5. BRAKES. Ensure proper operation. Brake should not slip with test load (10% of capacity). If external inspection indicates the need, disassemble. Brake discs must be free of oil or grease, unglazed, uniform and at least 5/64 inch (2 mm) thick. Check all other brake surfaces for wear, deformation or foreign deposits. Check pawl brake, gear teeth should be undamaged, and stop gear rotation counterclockwise. Check pawl spring for damage. Clean and replace components as necessary.
6. SUPPORTING STRUCTURE. Check for distortion, wear and continued ability to support load.
7. LABELS. Check for presence and legibility. Replace if necessary.
8. END ANCHOR. Ensure end anchor on chain hoist is engaged and unbent. Repair if damaged, replace if missing. See "Attaching End of Load Chain" under "MAINTENANCE."
9. LOAD CHAIN. Measure the chain for stretching by suspending a light load (50 to 100 pounds) from the hoist and measuring across five link sections all along the chain as illustrated below. When any five links in the working length reaches or exceeds the discard length, replace the entire chain. Always use a genuine INGERSOLL-RAND Material Handling Products replacement chain.

Model No.:	Part No.:	Chain Size: (mm)	Normal Length:		Discard Length:	
			in.	(mm)	in.	(mm)
VL150	LCCF025	9.0	5.35	136.0	5.47	138.8
VL200	LCCF025	9.0	5.35	136.0	5.47	138.8

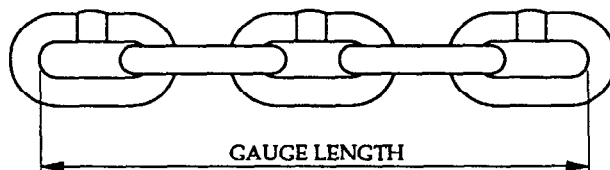

LUBRICATION

Gears (11 and 14)

Unscrew nuts (36), on opposite side of hoist as hand chain, and remove gear cover (17). Remove old grease and replace with new. For temperatures -20 to 50 F (-29 to 10 C) use EP 1 grease or equivalent. For temperatures 30 to 120 F (-1 to 49 C) use EP 2 grease or equivalent.

Load Chain

WARNING: Failure to maintain clean and well lubricated load chain will void the manufacturer's warranty.

1. In a corrosive environment, lubricate more frequently than normal.
2. Lubricate each link of the chain and apply new lubricant over existing layer.
3. Lubricate hook and safety latch pivot points.
4. Use BEEBE Lubri-Link or a SAE 50-90W EP oil.
5. Clean chain with acid free solvent to remove rust or abrasive dust build-up. After cleaning, lubricate chain.
6. Lubricate load chain weekly, or more frequently, depending on severity of service.

MAINTENANCE

WARNING: Never perform maintenance on the hoist while it is supporting a load.

WARNING: Before performing maintenance, tag controls: DANGER - DO NOT OPERATE - EQUIPMENT BEING REPAIRED.

WARNING: Only allow qualified service personnel to perform maintenance.

WARNING: Test hoist to 125% of its rated capacity before returning to service.

Installing New Chain

1. Ensure welds of "standing" links on the new chain are facing away from the load sheave (6).
2. Ensure load chain (43) is reeved between load sheave (6) and chain guides (7).
3. Hook (38) must be on left fall of load chain (43) and right fall must be attached to hoist body with end anchor (21 and 22). Right and left are designated when viewed from the hand chain side of the hoist.

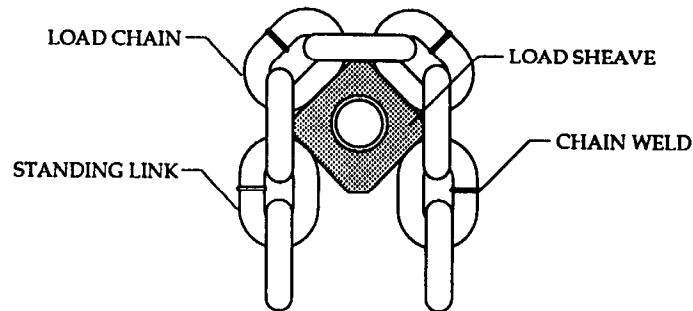

4. When reeving the chain between the idler sheaves on the bottom and top hook assembly, make sure the chain does not become twisted.

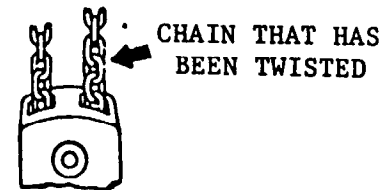
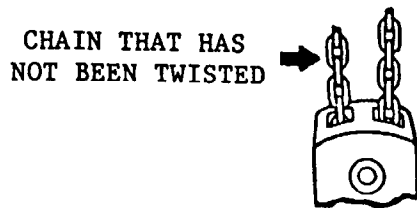

Attaching End of Load Chain

1. With end anchor A (21) removed, attach end link of load chain (43) to pin on end anchor B (22). Ensure load chain (43) is not twisted, kinked or "capsized."
2. Insert pin on end anchor B (22) into end anchor A (21). Then slide end pin (20) through end anchor A (21) and into side plate.

Brake Adjustment

1. Remove nuts (36) and wheel cover (35) so that hand wheel (31) is exposed.
2. Remove hairpin cotter (34) and tighten pinion nut (33) (Clockwise).
3. Back off pinion nut (33) a 1/8 of a turn (Counterclockwise) and re-insert hairpin cotter (34).

Disassembly

Use the following procedure to replace the brake discs.

1. Remove nuts (36) and wheel cover (35).
2. Remove hairpin cotter (34), pinion nut (33) and washer (32).
3. Remove hand wheel (31), by holding load chain (43) and rotate hand wheel (31) counterclockwise.
4. Remove brake cover (30) and brake disc (27).
5. Remove ratchet gear (29) and brake disc (28).

Assembly

1. Place brake disc (28) over hub (26). Brake disc (28) is narrower than disc (27).
2. Install ratchet gear (29) over hub (26). Teeth of ratchet gear (29) must engage pawl (24). Ratchet gear (29) should not rotate counterclockwise and should "click" when rotating clockwise.
3. Place brake disc (27) on ratchet gear (29).
4. Ensure hand chain (42) is properly seated in hand wheel (31).
5. With brake surface of hand wheel (31) towards brake disc (27), place hand wheel (31) on pinion shaft (13) and rotate hand wheel (31) clockwise until clicking occurs.
6. Place washer (32) over pinion (13). Install nut (33) and hairpin cotter (34) using "Brake Adjustment."
7. Position wheel cover (35) and secure with nuts (36).

VL150 AND VL200 MANUAL CHAIN HOIST PARTS LIST

ITEM	DESCRIPTION	QTY	VL150 & VL200
1	SIDE PLATE 1	2	2372902
4	BEARING	4	2372903
6	LOAD SHEAVE	2	2372905
7	LOAD CHAIN GUIDE	4	2372872
8	CHAIN STRIPPER	2	2372873
9	SIDE PLATE 2	2	2372906
10	GEAR BUSHING	8	2372875
11	FIRST GEAR	2	2372907
13	PINION SHAFT	2	2372877
14	SECOND GEAR	4	2372908
15	THIRD GEAR	4	2372909
16	SUPPORT PLATE	2	2372910
17	GEAR COVER	2	2372911
18	HOOK PIN	4	2372912
19	END SPRING	2	2372797
20	END PIN	2	2372883
21	END ANCHOR A	2	2372884
22	END ANCHOR B	2	2372885
23	SPRING	2	2372913
24	PAWL	2	2372887
25	SNAP LINK	2	2372888
26	HUB	2	2372889
27	BRAKE DISC A	2	2372890
28	BRAKE DISC B	2	2372982
29	RATCHET GEAR	2	2372891
30	BRAKE COVER	2	2372914
31	HANDWHEEL	2	2372915
	HANDWHEEL, COPPER PLD	2	2372915CP
32	WASHER	2	2372810
33	PINION NUT	2	2372811
34	COTTER PIN	2	2372812
35	WHEEL COVER	2	2372916
36	U-NUT	12	2372895
42*	HAND CHAIN, REGULAR	2	HCCV020
	HAND CHAIN, ZINC PLD	2	HCCV020ZP
	HAND CHAIN, STAINLESS STL	2	54137
43*	LOAD CHAIN, REGULAR	1	LCCF025
	LOAD CHAIN, NICKLE-DIF	1	LCCF025ND

*SPECIFY LENGTH

CHAIN HOIST PARTS LIST FOR MODEL VL

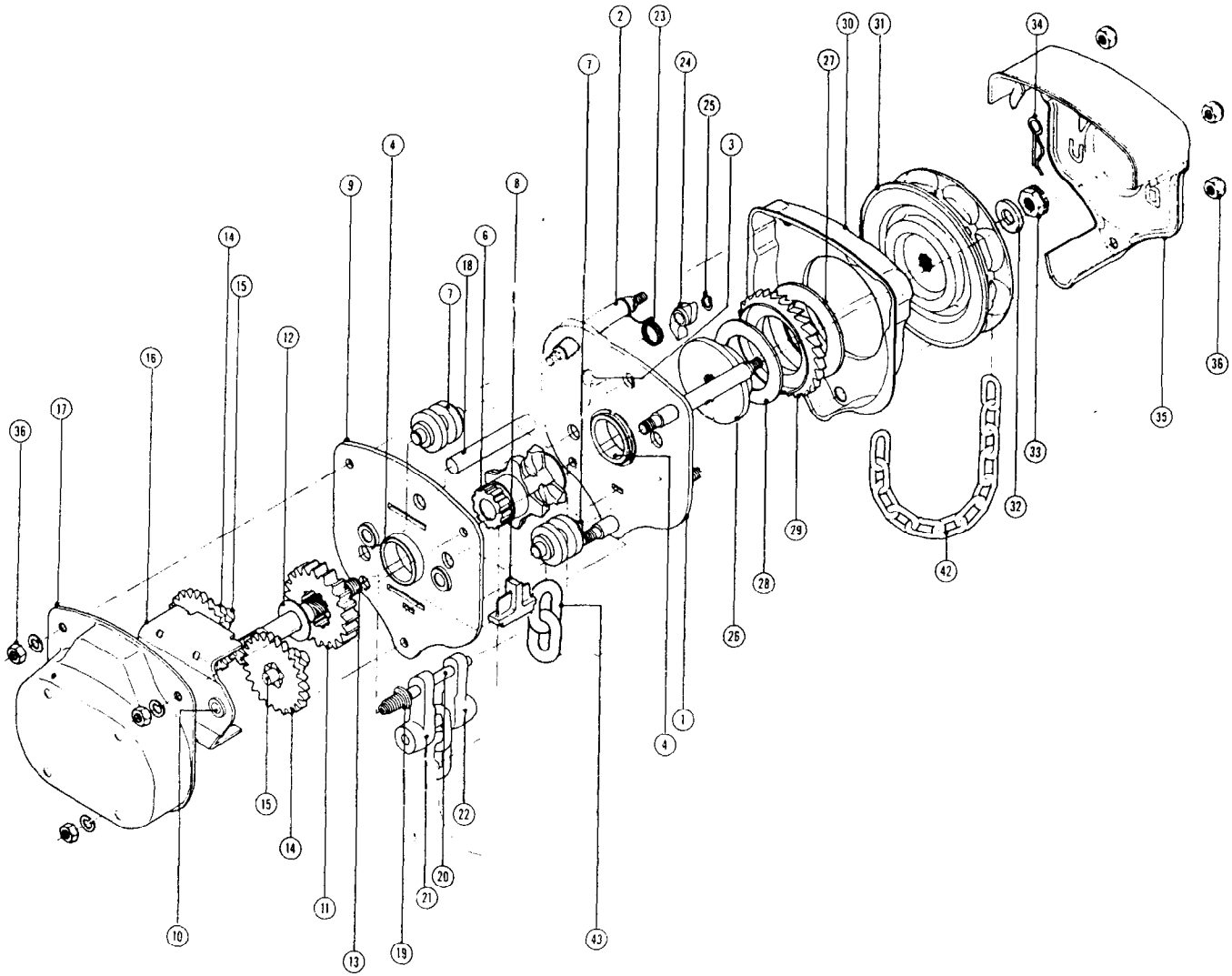

CHAIN REEVING

VL150

VL200

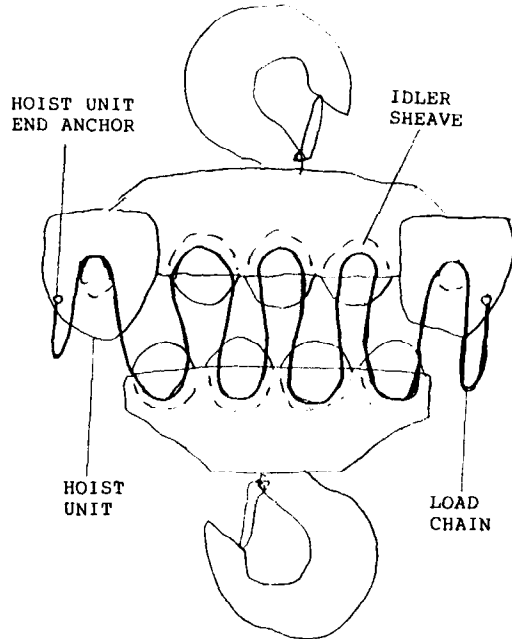
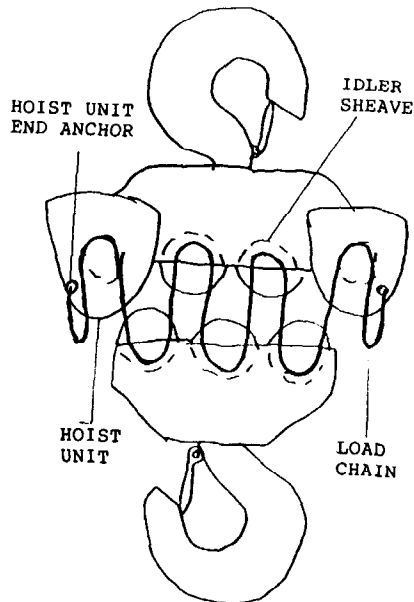

HOOK PARTS FOR VL150 AND VL200

ITEM	DESCRIPTION	QTY	VL150	VL200
41	SAFETY LATCH	2	***	***
45	TOP HOOK	1	***	***
	TOP HOOK, COPPER PLATED	1	***	***
**	TOP HOOK, BRONZE			
46	TOP FRAME	2	***	***
48	BOTTOM HOOK	1	***	***
	BOTTOM HOOK, COPPER PLD	1	***	***
**	BOTTOM HOOK, BRONZE			
49	BOTTOM FRAME	2	***	***
50	AXLE	5/7	2372947	2372947
51	SHEAVE	5/7	2372948	2372948
52	AXLE BEARING	10/14	2372949	2372949
57	YOKE BOLT A	7/9	2372904	2372904
58	YOKE NUT	7/9	2372897	2372897
60	YOKE BOLT B	4	***	***
61	YOKE WASHER B	4	***	***
62	YOKE NUT B	4	ORDER AS A SET WITH ITEM 61	

** CONTACT FACTORY FOR MORE INFORMATION

*** ORDER PART BY MODEL, PART NAME & ITEM NUMBER

VL150
15 TON

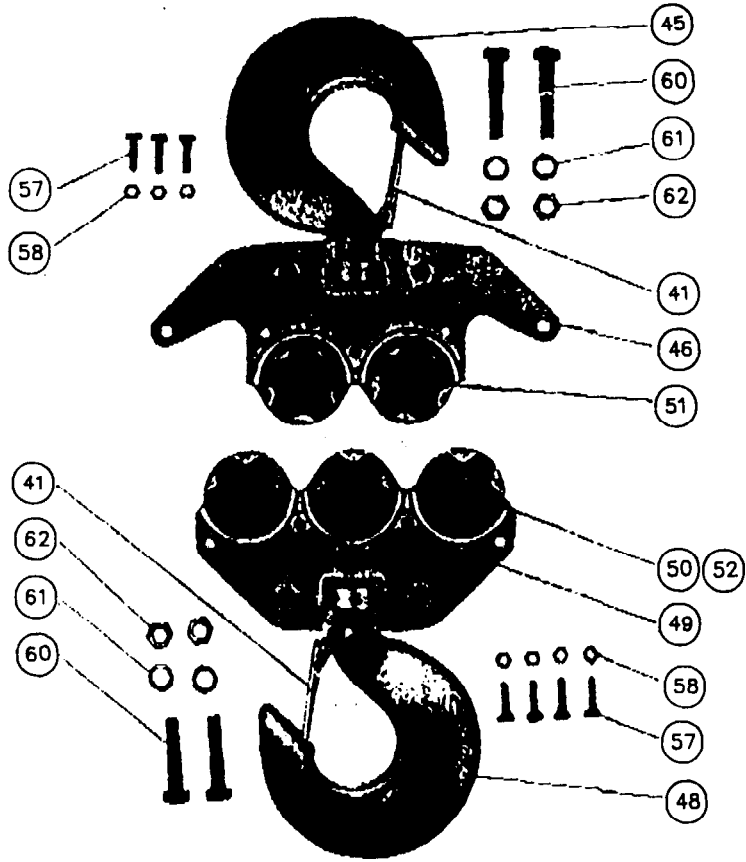

VL200
20 TON

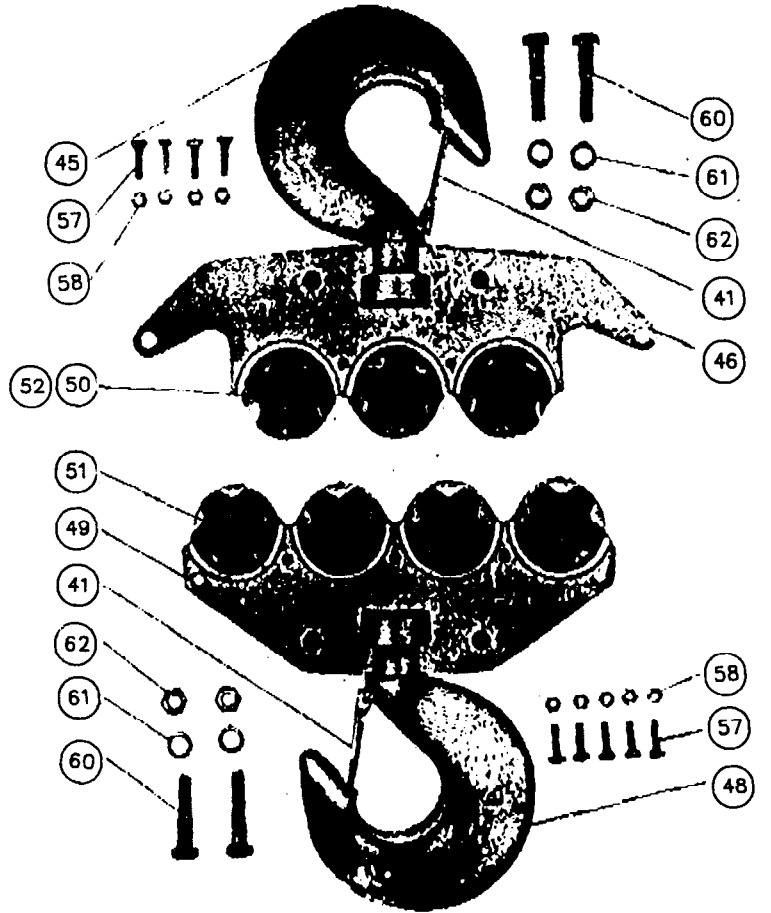

WARRANTY

INGERSOLL-RAND Material Handling Products ("Manufacturer") extends the following warranty to the original purchaser ("Purchaser") of each new product ("Product") manufactured or sold by it.

(a) Manufacturer warrants Product to be free from defects in material and workmanship under normal use and service for a period of one year from Manufacturer's original sale.

(b) Manufacturer's liability and Purchaser's sole remedy under this warranty, and for any and all other claims arising out of the purchase and use of Product, including any alleged negligence on the part of Manufacturer, is limited to repair or replacement, at Manufacturer's option, of such defective Product or part thereof, provided that the defective Product or part thereof is returned to Manufacturer's factory or authorized service center, transportation prepaid, and that examination by Manufacturer discloses that the Product is defective under the terms of this warranty.

(c) Manufacturer does not warrant components of products provided by other manufacturers. However, to the extent possible, Manufacturer will pass along to Purchaser applicable warranties of such other manufacturers.

(d) This warranty is conditioned upon installation and use of Product in accordance with Manufacturer's operating instructions. This warranty is IN LIEU OF ALL OTHER WARRANTIES, EXPRESS OR IMPLIED, INCLUDING BUT NOT LIMITED TO ANY WARRANTY OF MERCHANTABILITY OR FITNESS FOR A PARTICULAR PURPOSE. Manufacturer shall have no liability or obligation as to any Product which has been misused, altered or changed in any way, including without limitation use of a "cheater" handle for extra leverage on hoists or pullers, conversion of hand winches or hoists to power operations* or use of any Product for lifting, lowering or moving persons.

(e) MANUFACTURER SHALL IN NO EVENT BE LIABLE FOR INCIDENTAL OR CONSEQUENTIAL DAMAGES arising from the sale, delivery or use of Products.

Manufacturer neither assumes nor authorizes any person to assume for it any other liability or obligation in connection with sale and use of Products other than stated above. Caution: Purchaser and user are cautioned to examine specific, local or other regulations, including American National Standard Regulations, which may apply to a particular type of product before installing or putting to use.

*Except power rewinding pursuant to operating instructions

Please Note: Units purchased without chain and/or hooks must have Ingersoll-Rand Material Handling Products chain and hooks installed before the warranty is valid.

Shipping Damage

It is our policy to promote safe delivery of all orders.

This shipment has been thoroughly checked, packed and inspected before leaving our plant and receipt for it in good condition has been received from the carrier. Any loss or damage which occurs to this shipment while enroute is not due to any action or conduct of the manufacturer.

Visible Loss or Damage: If any of the goods called for on the bill of lading or express receipt are damaged or the quantity is short, do not accept them until the freight or express agent makes an appropriate notation on your freight bill or express receipt.

Concealed Loss or Damage: When a shipment has been delivered to you in apparent good condition, but upon opening the crate or container, loss or damage has taken place while in transit, notify the carrier's agent immediately.

Damage Claims: You must file claims for damage with the carrier. It is the transportation company's responsibility to reimburse you for repair or replacement of goods damaged in shipment. Claims for loss or damage in shipment must not be deducted from the Ingersoll-Rand invoice, nor should payment of Ingersoll-Rand invoice be withheld awaiting adjustment of such claims as the carrier guarantees safe delivery.

You may return products damaged in shipment to us for repair, which services will be for your account and form your basis for claim against the carrier.

INGERSOLL-RAND
MATERIAL HANDLING PRODUCTS
2724 SIXTH AVENUE SOUTH, SEATTLE WASHINGTON 98134-2102
PHONE (206) 624-0466, TELEX: 3723554, TELEFAX: (206) 447-0715
P.O. BOX 24046, SEATTLE, WASHINGTON 98124-0046