

LIFTSTAR[®] 150 R

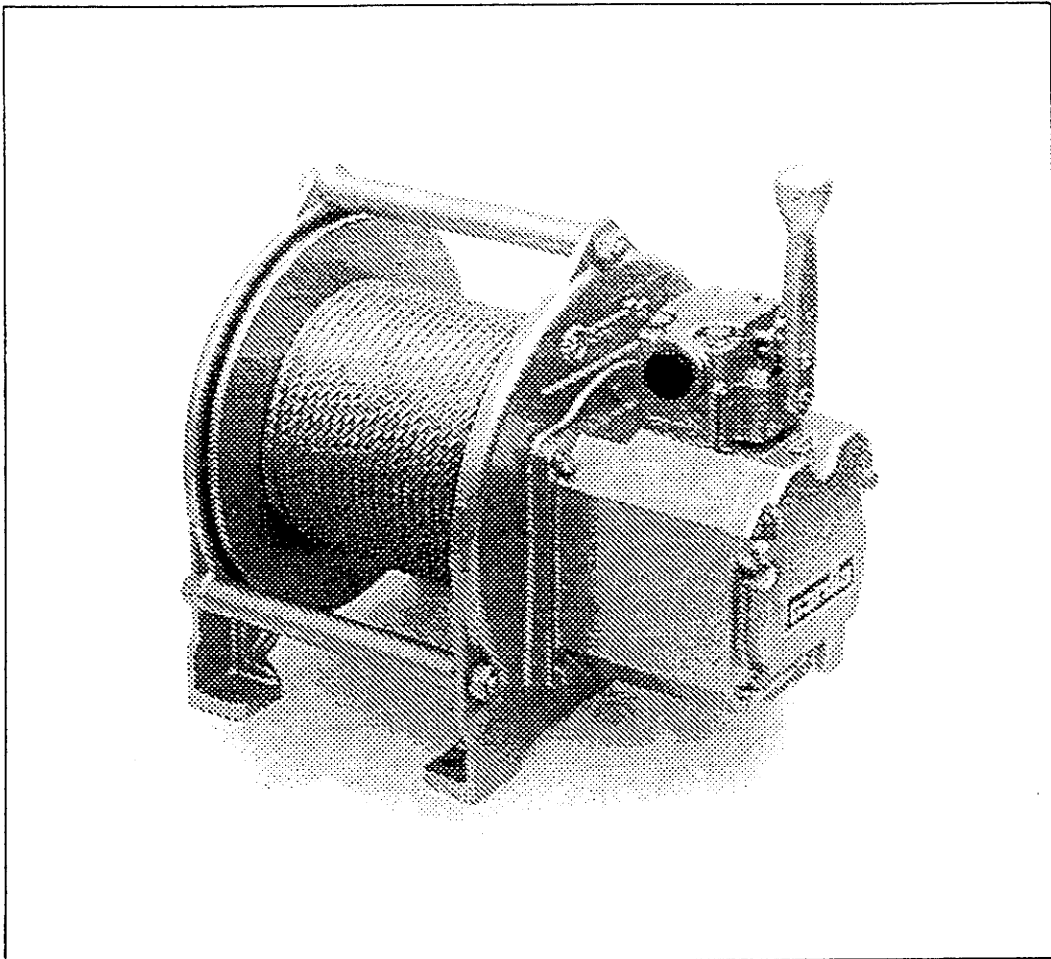

Instructions handbook



**PLEASE CAREFULLY READ THE DIRECTIONS
FOR USE BEFORE STARTING UP**

SUMMARY	FOLIO NBR.
* DESCRIPTION	1/1
* TECHNICAL DATA	1/1
* PRACTICAL ADVICE	
- Putting into operation	1/5
- Maintenance	2/5
- Particular instructions	2/5
- Overhauling	3/5
* WARRANTY	5/5
* SPARE PARTS	
- General view	1/4
- Spare parts list	2/4 - 3/4 - 4/4

LIFTSTAR® 150 R

Portable air lifting winch

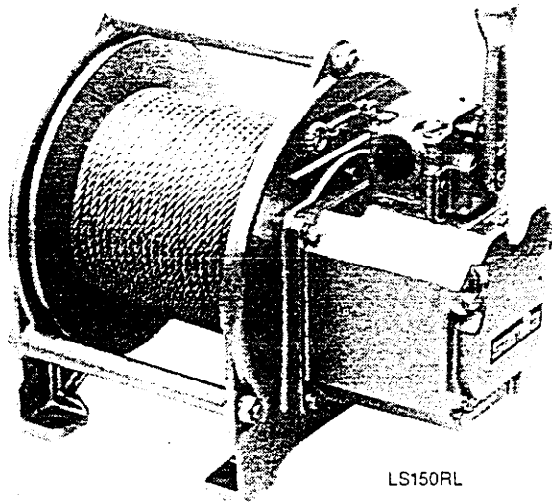

LS150RL

DESCRIPTION

- Portable air winch, weight less than 30 kg, yet steel construction.
- Compact design for easy carrying using only one hand.
- Conforms with the most recent lifting standards (NF - ANSI - BSI - DIN) and with the requirements of certification authorities for Marine, Mines and Public Works. FEM classification 1Bm.

Design

- Plain drum between flanges with distance pieces - rope anchored by a horizontal self-tightening wedge.
- Planetary reduction gear enclosed in drum for protection and space saving.
- All rotating parts supported on anti-friction bearings.

Motor

- Gear motor - Provides high starting torque.
- Motor reliability demonstrated by thousands of winches working in many mines. Simple rotating movement, more tolerant of poor quality air than other types of air motors.

SPECIFICATIONS

Nominal load - Rated all layers (Kg)	150		
Working pressure (bar)	4 to 7		
Rules and safety factors	$\frac{\text{Drum } \varnothing + \text{Rope } \varnothing}{\text{Rope } \varnothing} = \text{Factor R} \geq$	36	24
	$\frac{\text{Rope breaking}}{\text{Nominal effort}} = \text{Factor K} \geq$	6	6
	Recommended rope diameter (mm)	4	6
Minimum breaking load (Kg)	900	900	
Recommended rope grade (Kg/mm ²)	160	160	
Weight of std. model - without rope (Kg)	28		

PERFORMANCE

Line pulls and speeds (see curves overleaf)	
Max. free air consumption (m ³ /min)	2.2

- Reduced noise level (air is exhausted through the drum, resonances are minimised).

Safety brake

- Fail safe automatic disc brake.
- Independent from worm gear drive and generously designed for dynamic overloads of 125% and static of 150%.

Controls

- Direct control on the winch using only one lever - giving infinitely variable speed.
- As an option, remote control "PHS" (high sensitivity pendent with variable speed) connected to the winch by a flexible hose bundle (up to 20 m distance).

Options

- Version "GC" available (great capacity) with long drum -
- For haulage operations this winch is offered in the "PULLSTAR" version with a declutchable drum (Ask for details).

WARNING : This equipment is not designed for transport of persons. For all applications, please read carefully the advice in our installation and maintenance manual.



LIFTSTAR® 150 R

Portable air lifting winch

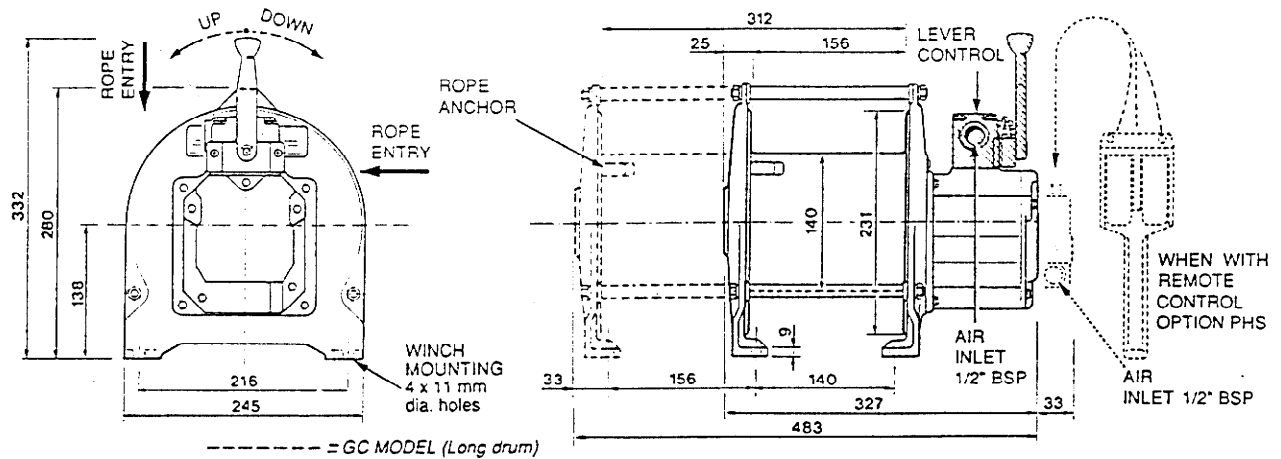

Performance at 6.3 bar - Rope 6 mm dia.

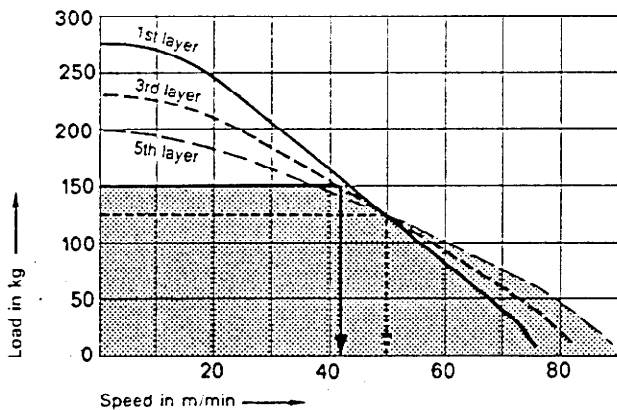

Cumulative rope capacity

Cumulative rope capacity according to various layers in metres. (Double the figures for model GC - long drum).

Number of layers	1	2	3	4	5	6	7	8	9	10
Rope 4 mm Ø	16	33	52	71	91	112	134	157	181	206
Rope 6 mm Ø	11	22	35	49	64	79	96	-	-	-

Rating limit —

Designation and options

Standard model : LS150R-L

For other configurations, use this identification code to order ; Example :

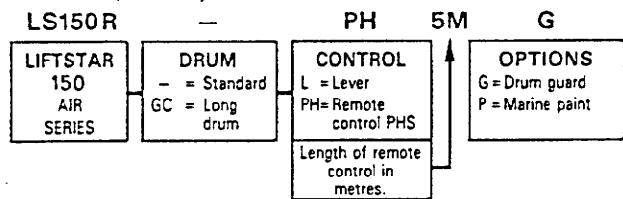

Accessories

DESIGNATION	CODE S	CPN
Steel lubricator 3/4" BSP	33971909	38530879
Steel lubricator 3/4" x 1/2" BSP	36180026	38529251
Steel air filter 3/4" BSP	34282079	38530867
Steel air filter 3/4" x 1/2" BSP	36180027	38529277
Filter-lubricator 1/2" BSP (F.L.)	39990065	38529673
Filter-regulator-lubricator 1/2" BSP (F.R.L.)	39990064	38529665

The equipment described on this sheet is subject to the general sales and warranty conditions of SAMIIA. Because of the constant evolution of technology, SAMIIA reserves the right to modify without notice the specification of any equipment or accessory.



For the name of your local distributor, contact
SAMIIA-France.: Fax (33) 2793.08.00 - Telex 820221

PUTTING INTO OPERATION

* Network connection

The LIFTSTAR network connection to the compressed air supplying flexible is made on the inlet port \varnothing 1/2" G located on the distributor. The internal diameter of the supplying circuit does not be inferior to 13 mm for the flexibles and 10 mm for the connections.

Before connecting the supplying flexible to the LIFTSTAR, it is necessary to take away the air in order to exhaust impurities which should be in the flexible.

When starting the LIFTSTAR, we recommend you beginning supplying slowly in order to obtain a slow rotation of the motor and propelling it in the 2 directions during a few minutes with a good lubrication.

* Lubrication of the motor

We advice you to install an air treatment set near the equipment (maximum 3 meters) : Filter - Regulator - Lubricator code : 67763932, or Filter - Lubricator code 67770232.

The oiler must be regulated at 2/3 drops per minute. When filling in the oiler, the air inlet must be closed.

- Recommended oil : GRADE ISO 150

- Minimum viscosity : 135 Cst at 40°

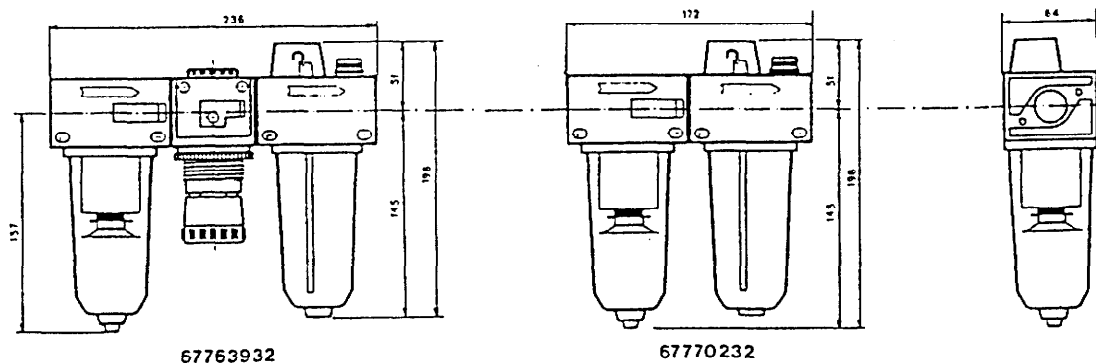

* Rope fitting

Introduce the rope in the drum according to the direction stated in the technical sheet (page 3).

Fit the wedge code : 9-618-0006

Make sure the rope appears on the drum flange.

MAINTENANCE

• Motor

If the LIFTSTAR is used in a continuous way, you will have to fill in the line oiler each day.

• Guiding belts

Monthly lubrication of the guiding belts with the oiler code : 67102227 (when lubricating, make an idle running of the drum).

Oil features :

Semi fluid oil extreme pressure for a room temperature from - 15° C to + 40° C,
ASTM at 25° C penetration.

CAUTION : THE OILS CONTAINING MOLYBDENUM ARE TO BE ABSOLUTELY PROSCRIBED.

PARTICULAR INSTRUCTIONS

• Before stopping the LIFTSTAR for a long period :

- Pour some cm³ of oil in the air inlet port or the supplying flexible.
- Propel the motor during 2/4 seconds
- Close the LIFTSTAR air inlet port

• When starting again :

Before a stopping period exceeding 1 month, we recommend to clean and lubricate the LIFTSTAR motor as follows :

- Pour approximately 10 cm³ of petroleum or gasoil in the air inlet port.
- Propel the motor during 10 seconds to exhaust any impurity.
- Pour some cm³ of oil in the air inlet port.
- Propel the motor during 2/4 seconds.

The LIFTSTAR is ready to work.

OVERHAULING

* BRAKE

The disc brake does not require any regulation, the yearly maintenance for this assembly being limited to :

- Dedusting
- Oiling the brake springs
- Replacing the disc brake when its thickness is inferior to 2,5 mm (original thickness : 3,2 mm).

CAUTION :

To access to the brake requires to dismount the carter / motor assembly
code : 6-618-0015.

When reassembling it, some precautions must be taken so that the coupling box code : 9-618-0014 and
the pin 46406118 be correctly fitted.

- Put the ring code : 9-618-0012 with the pin below
- Fit the carter / motor assembly, without the springs code : 69165532
- Dismount the carter / motor assembly
- Fit the springs
- Reassemble the carter / motor unit
- Make sure the mounting is correct by compressing the springs

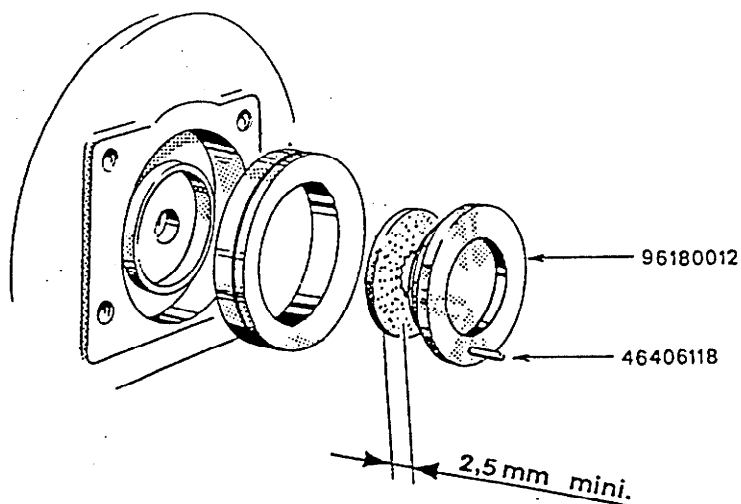

• Reducer

The yearly maintenance is limited to :

- Cleaning with petroleum
- Filling in the carter of the reducer with oil till the working rim be covered (oil capacity : 20 cl)

Recommended oil : GRADE SAE 80 W 90
Kinematic viscosity : 145 mm²/s at 40° C

CAUTION

As regards the reassembling of the reducer gears, it is necessary to place the 2 planet wheels as follows, with the assistance of the codes carved on the lateral side of these planet wheels.

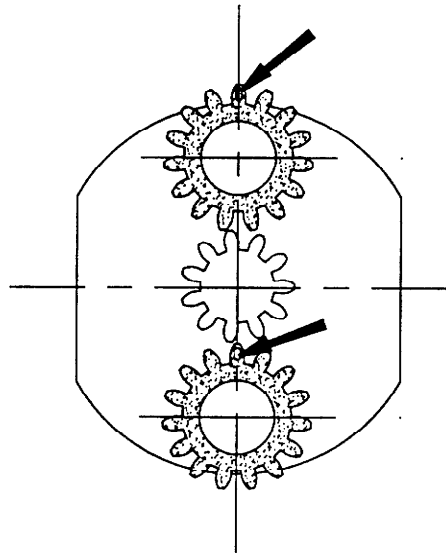

• Motor

As far as the yearly maintenance of the motor is concerned, act as described in the paragraph "when starting again".

If this operation is not sufficient, dismantle the motor and make :

- General cleaning
- Lubrication of the gears oil grade ISO 150 - Viscosity : 135 Cst at 40° C
- Addition of grease in the bearings

CAUTION

As regards the cleaning of the LIFTSTAR parts, use preferably :

PETROLEUM - GASOIL - ERGEOL -
NEVER CLEAN PARTS WITH TRICHLOROETHYLENE

Regarding the braking of the assembling screws, use an anaerobic resin, which allows dismantling without damage (resin type LOCTITE - BRAKE) (blue line or equivalent).



B.P 59
59450 SIN LE NOBLE - FRANCE
TEL (33) 27.93.08.08
TELEX 820 221
TELEFAX (33) 27.93.08.00

TREUIL DE LEVAGE PNEUMATIQUE
DRUCKLUFT SICHERHEITS-HUBWINDE
AIR POWERED LIFTING WINCH

LIFTSTAR 150R

NUMERO DE NOMENCLATURE

NUMERO DU DOCUMENT

9,3,1,2,1,0, | 5/5

MA
LE CHEF DU BUREAU D'ETUDES

• Guiding belts

The guiding belts code : 9-618-0028 are 1,5 mm thick.
A 0,5 mm wear implies their replacement. Act as follows :

- Take away the guiding belts by hand.
- Carefully scrape the glue from the bearing.
- Put some glue stitches on the polished side of the belts : LOCTITE 406
(very little glue is necessary) (the connection between the belts must be
at 40 mm from the oiling hole).
- Place the guiding belts and set them in their housing
(DO NOT LEAVE ANY CLEARANCE BETWEEN THE BELTS AND THE BEARING).
- Lubricate the guiding belts before reassembling the drum.
Complete with the oiler.

WARRANTY

The warranty conditions for this equipment are those mentioned in the SAMIIA general sales conditions enclosed with our offers and printed on the back of our acknowledgements of receipt and invoices.

REPÈRE PART TEIL	Quantité Quantity Anzahl	DESIGNATION	DESCRIPTION	BEZEICHNUNG
9.412.0030	1	Butée arrière	Rear stop	Anschlag hinten
9.609.0008	1	Flasque avant moteur	Motor front end-cover	Außeres Seitenteil des Motors
96090095	2	Bague entretoise	Distance piece	Distanzring
9.609.0030	1	Ensemble rotor et répulsion	Rotor and repulsion assy	Rotor und Repulsion Einheit
9.609.0031	1	Ensemble rotor moteur	Motor rotor assy	Motor Rotor Einheit
9.609.0032	1	Rondelle	Washer	Scheibe
9.609.0038	1	Couronne 49 dents	49 teeth-ring gear	Zahnkranz 49 Zähne
9.609.0039	2	Axe de satellite	Satellite axle	Trabantenachse
9.609.0113	1	Piston de vérin	Cylinder piston	Zylinderkolben
9.609.0049	1	Disque de frein	Brake disc	Bremsscheibe
9.618.0001	1	Flasque arrière	Rear end-cover	Inneres Seitenteil
9.618.0002	1	Flasque avant	Front end-cover	Außeres Seitenteil
9.618.0005	1	Carter réducteur	Gear housing	Getriebegehäuse
9.618.0006	1	Coin	Wedge	Keil
9.618.0057	1	Palier	Bearing	Lager
9 609 0094	1	Couronne 45 dents	45 teeth-ring gear	Zahnkranz 45 Zähne
96090096		Satellite	Satellite	Trabant
9.618.0061	1	Arbre de sortie	Output shaft	Abtriebswelle
9.618.0011	1	Pignon aîné	Shaft spindle	Ritzelwelle
9.618.0012	1	Rondelle d'appui	Washer	Scheibe
9.618.0014	1	Manchon d'accouplement	Coupling sleeve	Kupplungsmuffe
9.618.0015	1	Carter moteur	Motor housing	Motorgehäuse
9.618.0024	1	Entretoise	Spacer	Abstandsring
9.618.0058	2	Bague de guidage	Guiding ring	Führungsring
9.618.0029	1	Couvercle moteur	Motor cover	Motordeckel
9.618.0030	2	Joint	Joint	Dichtung
9.618.0031	1	Levier de commande	Control lever	Steuerungshebel
9.618.0032	1	Corps de distributeur	Valve housing	Verteilergehäuse
9.618.0033	1	Carotte de distribution	Rotary valve	Umsteuerküken
9.618.0034	1	Butée	Stop	Anschlag
9.618.0035	1	Ressort de rappel	Return spring	Rückholfeder
9.618.0037	1	Oblurateur	Blind washer	Dichtung
9.618.0038	1	Clapet	Stopper	Klappe
9.618.0039	1	Entretoise	Distance piece	Distanzring
96090014	1	Porte-satellite	Satellite support	Satellitenträger
9.618.0042	1	Joint papier	Paper joint	Papierdichtung
9.609.0007	1	Corps moteur	Motor housing	Motorgehäuse
4.100.0101	3	Vis HM 6 x 20	Screw	Schraube
4.100.0201	4	Vis HM 6 x 15	Screw	Schraube
4.100.7501	2	Vis HM 6 x 25	Screw	Schraube
4.101.6601	4	Vis HM 6 x 60	Screw	Schraube
4.110.3403	2	Vis F Hc/90 M 5 x 10	Screw	Schraube
4.110.3903	4	Vis F Hc/90 M 6 x 70	Screw	Schraube
4.130.0806	4	Vis CHc M 6 x 80	Screw	Schraube
4.130.6706	1	Vis CHc M 5 x 10	Screw	Schraube
4.300.0211	6	Ecrou Hu 10	Nut	Mutter
4.520.0006	13	Rondelle Grower W 6	Washer	Scheibe
4.520.0010	6	Rondelle Grower W 10	Washer	Scheibe
4.600.0416	6	Goupille 8 x 20	Pin	Stift

Pour toute commande de pièces de rechange, il est recommandé de rappeler le numéro porté sur la plaque d'identification de l'appareil
 For each demand of spare parts, it is recommended to specify the number written on the identification plate of the device
 Bei Bestellung von Ersatzteilen bitte Seriennummer auf dem Identifizierungsschild des Geräte angeben

REPERE PART TEIL	Quantité Quantity Anzahl	DESIGNATION	DESCRIPTION	BEZEICHNUNG
4.600.1116	2	Goupille 6 x 16	Pin	Stift
4.600.1216	2	Goupille 6 x 24	Pin	Stift
4.650.7220	1	Goupille 3x20	Pin	Stift
4.640.6118	1	Goupille G 05 4 x 14	Pin	Stift
4.770.0012	1	Circlips E 12	Circlips	Seegerring
4.770.0015	1	Circlips E 15	Circlips	Seegerring
4.770.0029	1	Circlips E 29	Circlips	Seegerring
4.770.3032	1	Circlips I 32	Circlips	Seegerring
4.760.1339	2	Segment d'arbre WR9	Shaft segment	Wellensegment
4.780.2139	1	Circlips A 25 x 1,2 V	Circlips	Seegerring
5.000.0002	1	Roulement à billes 6002	Ball bearing	Kugellager
5.005.0006	1	Roulement à billes 6006 2RS	Ball bearing	Kugellager
5.005.0010	1	Roulement à billes 6010 2RS	Ball bearing	Kugellager
5.060.0002	2	Roulement à billes 5202	Ball bearing	Kugellager
5.080.0005	1	Roulement à billes 16005	Ball bearing	Kugellager
5.080.0006	1	Roulement à billes 16006	Ball bearing	Kugellager
5.080.0009	1	Roulement à billes 16009	Ball bearing	Kugellager
5.632.3225	1	Roulement à aiguilles HK 25 x 16 x 2RS	Needle bearing	Nadellager
5.646.1912	2	Roulement à aiguilles NKI 9/12	Needle bearing	Nadellager
56501513	4	Roulement à aiguilles	Needle bearing	Nadellager
5.700.0002	2	Ecrou KM 2	Nut	Mutter
5.801.7430	1	Bague d'étanchéité G 12x21x3	Sealing ring	Dichtring
5.801.7530	1	Bague d'étanchéité G 30x40x4	Sealing ring	Dichtring
5.820.5029	2	Joint torique OR 11 x 1,3	O'ring	O-Ring
5.821.2529	1	Joint torique OR 7,5 x 1,5	O'ring	O-Ring
5.821.8129	1	Joint torique OR 15 x 2,5	O'ring	O-Ring
5.821.8229	1	Joint torique OR 10 x 2	O'ring	O-Ring
5.821.7629	1	Joint torique OR 25 x 2,5	O'ring	O-Ring
5.822.0929	5	Joint torique OR 16 x 1,25	O'ring	O-Ring
5.822.2329	2	Joint torique OR 4 x 1	O'ring	O-Ring
5.823.2229	1	Joint torique OR 58 x 3	O'ring	O-Ring
5.823.2329	1	Joint torique OR 78 x 3	O'ring	O-Ring
5.822.4929	2	Joint torique OR 6 x 4	O'ring	O-Ring
6.710.2227	1	Graisseur	Greaser	Schmiernippel
6.914.3932	1	Ressort réf. 553	Spring	Feder
6.916.5532	4	Ressort T1 6,3x11,2x20	Spring	Feder
9.618.0064	1	Plaque d'échappement	Exhaust plate	Auslaßplatte
9.618.0065	1	Joint papier	Paper joint	Papierdichtung
9.618.0066	1	Joint papier	Paper joint	Papierdichtung
4.110.1203	4	Vis F Hc/90 M6 x 25	Screw	Schraube
*		<u>Pièces non représentées</u>	<u>Not represented parts</u>	<u>Nicht dargestellte Teile</u>
9.609.0223	1	Buté de sélecteur	Selector stop	Selektorsanschlag
6.940.1625	1	Bille	Ball	Kugel
5.821.2229	1	Joint torique	O'ring	O-Ring

Pour toute commande de pièces de rechange, il est recommandé de rappeler le numéro porté sur la plaque d'identification de l'appareil
For each demand of spare parts, it is recommended to specify the number written on the identification plate of the device
Bei Bestellung von Ersatzteilen bitte Seriennummer auf dem Identifizierungsschild des Geräte angeben



B.P 59
59450 SIN LE NOBLE - FRANCE
TEL (33) 27.93.08.08
TELEX 820 221
TELEFAX (33) 27.93.08.00

TREUIL PNEUMATIQUE DE LEVAGE
DRUCKLUFT - HUBWINDE
LIFTING AIR WINCH

LIFTSTAR 150R-L

NUMERO DE NOMENCLATURE

NUMERO DU DOCUMENT

9,3,1,2,1,1 14/4

LE CHEF DU BUREAU D'ETUDES

REPÈRE PART TEIL	Quantité Quantity Anzahl	DESIGNATION	DESCRIPTION	BEZEICHNUNG
<u>A</u>				
9.618.0004	3	Entretoise standard	Standard distance piece	Standarddistanzring
9.618.0069	3	Entretoise GC	GC distance ring	GC Distanzring
<u>B</u>				
9.618.0055	1	Tambour standard	Standard drum	Standardtrommel
9.618.0068	1	Tambour GC	GC drum	GC Trommel
4.780.0639	6	Anneau Truarc 130 (TGC)	Ring (GC drum)	Ring (GC Trommel)
6.760.0303	6	Pastille d'échappement (TGC)	Exhaust washer (GC drum)	Auslaßscheibe (GC Trommel)

Pour toute commande de pièces de rechange, il est recommandé de rappeler le numéro porté sur la plaque d'identification de l'appareil
For each demand of spare parts, it is recommended to specify the number written on the identification plate of the device
Bei Bestellung von Ersatzteilen bitte Seriennummer auf dem Identifizierungsschild des Geräte angeben

**SAMIHA**

B.P 127

59506 DOUAI CEDEX-FRANCE

TEL (33) 27.93.08.08

TELEX 820 221

TELEFAX (33) 27.93.08.00

HUILEUR DE LIGNE DRUCKLUFTÖLER LINE OILER

S. 30

N° 3.3971909

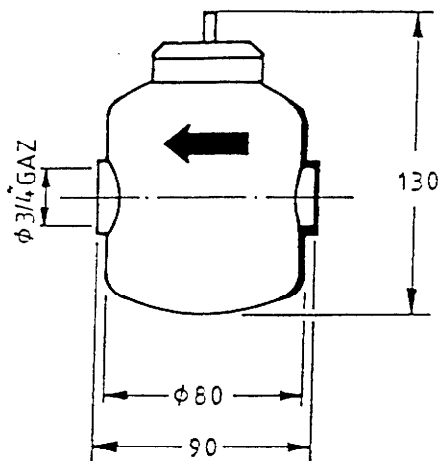

Côtés d'encombrement en mm

CARACTERISTIQUES

- Huileur à débit réglable pour installation fixe.
- Capacité 0,30 litre - Corps acier
- Valable pour débit de 500 à 5000 l/mn
- Pression d'utilisation 3 à 7 bar
- Diamètre d'entrée et sortie d'air filetés 3/4 gaz
- Poids : 1,200 Kg

BETRIEBSDATEN

- Öl mit einstellbarer Olabgabe für festen Bestandteilen
- Inhalt 0,30 Liter - Schale aus Stahl
- Für Durchfluss von 500 bis 5000 L/mn
- Betriebsdruck 3 bis 7 atü
- Lufteintritt und Luftaustritt 3/4" gasgewinde
- Gewicht : 1.200 kg

CHARACTERISTICS

- Oiler with adjustable flow for fixed installation
- Capacity 0.30 liter - Steel bowl
- Valid for air flow from 500 to 5000 l/mn
- Working pressure 3 to 7 kg/cm²
- Air entry and exhaust 3/4" gas
- Weight : 1,200 Kg

Masse über alles in mm

Overall Dimensions in mm

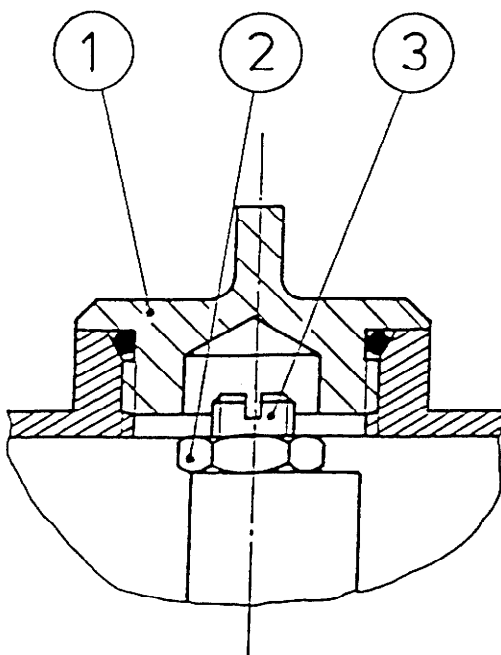
REGLAGE DU DEBIT D'HUILE

- . Fermer l'arrivée d'air - Dévisser le bouchon rep. 1
- . Desserrer le contre écrou rep. 2
- . Pour diminuer le débit d'huile, serrer la vis rep. 3
- . Pour augmenter le débit d'huile, desserrer cette vis (1/4 de tour suffit généralement)
- . Bloquer le contre écrou rep. 2 et remettre le bouchon

REGELUNG DER ÖLABGABE

- . Zuluft absperren - Stopfen Teil Nr1 abschrauben.
- . Kontermutter Teil Nr 2 lösen.
- . Für weniger Olabgabe, Schraube Teil Nr 3 abziehen
- . Für mehr Olabgabe, Schraube Teil Nr 3 lösen (1/4 Umdrehung genügt)
- . Kontermutter Teil Nr 2 blockieren und Stopfen 1 aufschrauben.

OIL ADJUSTMENT

- . Close the air inlet - unscrew plug part nbr 1
- . Loosen the lock nut part nbr 2. To reduce the oil flow, tighten screw part nbr 3. To increase the oil flow, loosen this screw (90° rotation is enough)
- . Screw the lock nut (part nbr 2) and install plug (part nbr 1)

NOTES



B.P 59
59450 SIN LE NOBLE - FRANCE
TEL (33) 27.93.08.08
TELEX 820 221
TELEFAX (33) 27.93.08.00