

INSTALLATION INSTRUCTIONS for FABRIC CHAIN CONTAINER KITS ML50K-K749-17 and ML50K-K749-45

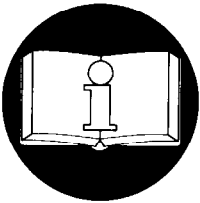

READ THIS INSTRUCTION SHEET BEFORE USING THE PRODUCT. This instruction sheet contains important installation information. Make this information available to all persons responsible for the operation, installation and maintenance of the product.

⚠ WARNING

- Disconnect the hoist from the air supply before installing a chain container kit.

Refer to illustrations TPB605-1 and TPD580.

1. Insert a container bolt (305) through the boss on the hoist housing and into the brackets (301 and 302). Retain the container with the bracket bolt nuts (304).

NOTICE

- If the container is to be allowed to swing outward, tighten the nuts to within one turn of being fully tight. This will allow the container to swing away from a load.

2. Apply the balance chain (307) to the container and hoist using the S-hooks (308). Adjust the length of the chain to prevent the load from rubbing on the container.

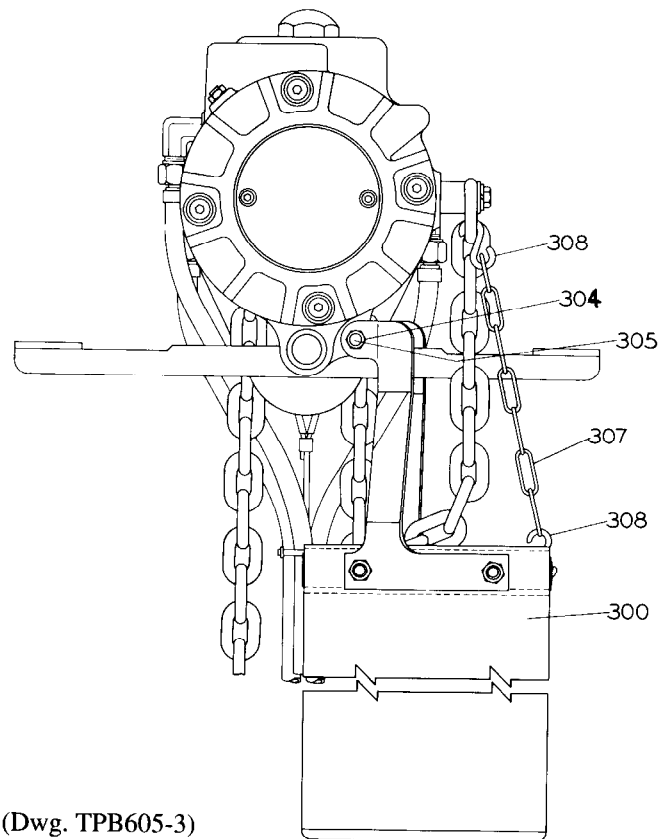

(Dwg. TPB605-3)

Refer All Communications to the Nearest
Ingersoll-Rand Branch Office or Distributor.

© 1993 Ingersoll-Rand Company
Printed in the U.S.A.

INGERSOLL-RAND®
MATERIAL HANDLING

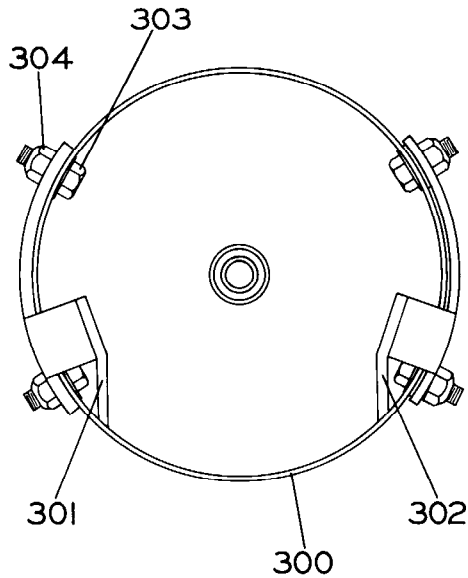

(Dwg. TPD580)

ITEM NO.	DESCRIPTION OF PART	QTY. TOTAL	PART NO.
300	Fabric Chain Container	1	---
	for ML50K-K749-17		ML50K-749-17
	for ML50K-K749-45		ML50K-749-45
301	Left Bracket	1	ML50K-748
302	Right Bracket	1	ML50K-747
303	Bracket Bolt	4	R2N-103
304	Bracket Bolt Nut	6	ML50K-394
305	Chain Container Bolt	2	5080-638
307	Balance Chain	1	CA110-240-1/2
308	S-Hook	2	D02-421

For Technical Support Contact:

Ingersoll-Rand Material Handling
P.O. Box 24046
2724 Sixth Avenue South
Seattle, WA 98124-0046
Phone: (206) 624-0466
Fax: (206) 624-6265

Ingersoll-Rand Material Handling
Samiia, Douai Operations
111, avenue Roger Salengro
59450 Sin Le Noble, France
Phone: (33) 27-93-08-08
Fax: (33) 27-93-08-00