

PISTON RING INSTALLATION INFORMATION

Select your Piston from the illustration below and install the Rings in the manner shown for your particular Piston. Some Piston Rings have an almost undetectable taper on the face that wipes the cylinder wall. The tapered Rings are identified by a "white dot" or machined "pip" mark on one face at a right angle to the wiping face. These Rings *must* be installed with the "white dot" or "pip" mark facing the head of the Piston. For clarity, the taper is exaggerated on the Rings illustrated below.

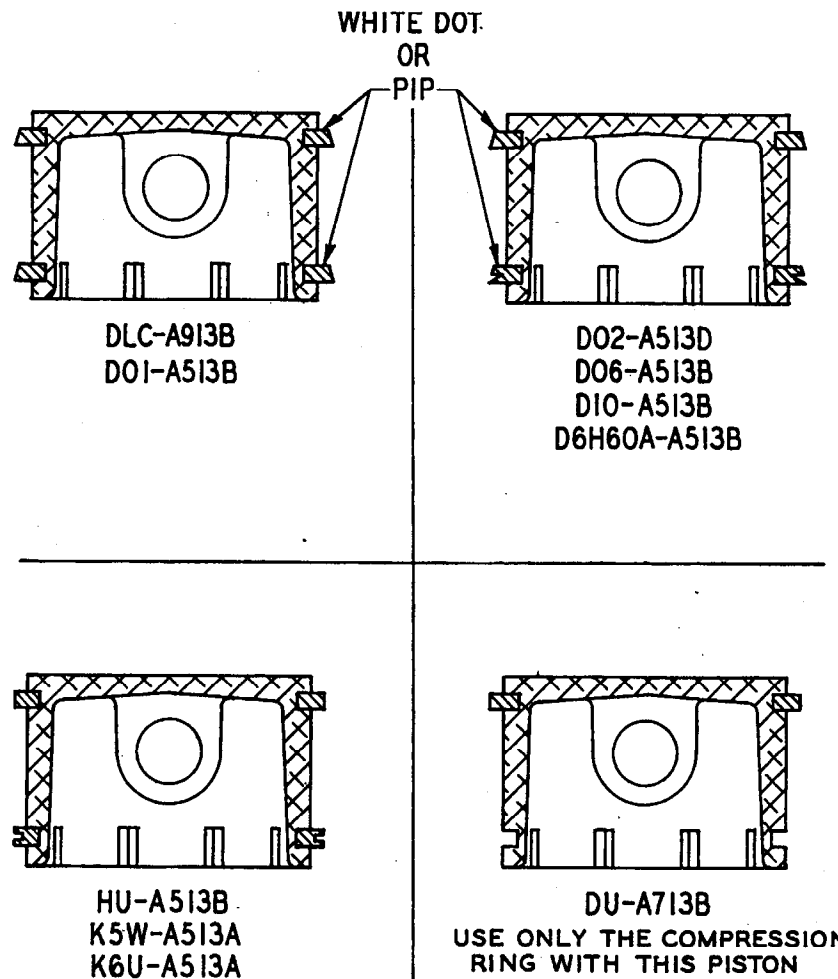

(Dwg. TPD796)

Refer All Communications to the Nearest
Ingersoll-Rand Branch Office or Distributor.

© 1996 Ingersoll-Rand Company
Printed in the U.S.A.

INGERSOLL-RAND
MATERIAL HANDLING

