

STATIONARY AIR MOTORS

Four-Cylinder, Nonreversible Sizes
CM, DM, D6M, EM, HM and KM

Four-Cylinder, Reversible Sizes
CCM, CCUM, DDM, DDUM, DD6M, DD6UM, EEM, EEUM,
HHM, HHUM, KKM and KKUM

Five-Cylinder, Nonreversible Sizes
E5M, H5M and K5M

Five-Cylinder, Reversible Sizes
EE5M, EE5UM, HH5M, HH5UM, KK5M and KK5UM

and

FLANGE-MOUNTED STATIONARY AIR MOTORS

Four-Cylinder, Nonreversible Sizes
CM56, DM56, D6M56, EM56, HM56 and KM56

Four-Cylinder, Reversible Sizes
CCM56, CCUM56, DDM56, DDUM56, DD6M56, DD6UM56, EEM56,
EEUM56, HHM56, HHUM56, KKM56 and KKUM56

Five-Cylinder, Nonreversible Sizes
E5M56, H5M56 and K5M56

Five-Cylinder, Reversible Sizes
EE5M56, EE5UM56, HH5M56, HH5UM56, KK5M56 and KK5UM56

HOW TO ORDER

Order all repair parts for your Ingersoll-Rand Tool by the **NAME** and **NUMBER** shown in the Repair Part List section. **Never** use the illustration numbers which appear in the first column.

For prompt service and genuine Ingersoll-Rand parts, place orders with the nearest Ingersoll-Rand Office or Authorized Distributor.

Notice: The use of other than genuine Ingersoll-Rand replacement parts may result in decreased tool performance and increased maintenance, and may, at the Company's option, invalidate all warranties.

Refer All Communications to the Nearest
Ingersoll-Rand Office or Distributor.

© Ingersoll-Rand Company 1978

Printed in U.S.A.



Ingersoll-Rand.

Ingersoll-Rand

LUBRICATION

WARNING: Lubricate the Motor before operating. To prevent leakage during shipment, all oil was drained from the Motor Case (1). Sufficient oil for one filling is contained in the can packed with the Motor. Before operating the Motor, close the Oil Cocks at the bottom and side of the Motor Case, unscrew the Vent Cap (3 or 4) and pour the entire contents of the can into the Motor Case.

Check the oil level daily.

When the Motor is not subjected to freezing temperatures: After the Motor has been idle for several hours or overnight, open the Oil Cock (2 or 3) located at the bottom of the Motor Case (1) and allow the accumulated water to drain out. Close the Oil Cock at the bottom and open the one on the side of the Motor Case. Remove the Vent Cap (3 or 4) and pour a sufficient quantity of the recommended oil through this opening to bring the oil level up to the open Oil Cock. Close the Oil Cock and replace the Vent Cap.

When the Motor is subjected to freezing temperatures: Allow the Motor to remain idle long enough for the water content in the Motor Case (1) to separate from the oil, but not long enough for it to freeze. Drain the water and replenish the oil as above. Should this procedure be impractical, drain the entire contents from the Motor Case immediately after operation ceases, and pour the oil back into the Motor Case before resuming operation. If not drained, a sufficient quantity of water will eventually accumulate so that the Oil Splasher (15) attached to the Crank (10) will freeze fast.

For Temperatures 30° to 80° F (-1.1 to 26.6° C), use Ingersoll-Rand Pneu-Lube® Medium Oil No. 50 or SAE 20 or 20W motor oil.

For Temperatures above 80° F (26.6° C), use SAE 30 motor oil.

For Temperatures below 30° F (-1.1° C), use SAE 10 or 20W motor oil.

Weekly insert a small quantity of Ingersoll-Rand Lubricant No. 28 or a good quality No. 2 cup grease into the Grease Fittings (81, 82 or 115) located in the Valve Chest (75 or 110). Two or three strokes from a hand grease gun are sufficient for each Fitting.

Every three months, or as experience indicates, remove the Grease Plug (47) from the Base (45) of Series H, H5, K and K5 Motors and fill the chamber with Ingersoll-Rand Heavy Gear Grease No. 70.

Ingersoll-Rand Air Line Lubricators are recommended for use with all Stationary Motors.

AIR STRAINER (Illustrated on pages 11 and 21)

To clean the Air Strainer, shut off the air supply and unscrew the Air Strainer Plug (403 or 664) from the Strainer Cap (404 or 663). Turn on the air momentarily and blow out the dirt. If the Screen (401 or 662) becomes clogged to the extent that the above method fails to clean it properly, unscrew the Cap from the Strainer Body (400 or 661), remove the Screen and wash it in kerosene or other solvent.

INSTALLATION

The Motor Case of a Stationary Motor can be rotated to any one of several different positions on the Base. When installation requires that the foot pad of the Base be attached to a wall or column, the Motor Case must be removed from the Base and rotated. Position the Motor Case so that the Oil Cock (2 or 3) (drain cock) is at or as close to the bottom vertical center as possible.

Note: The bolt spacing of Sizes H5M, HH5M, HH5UM, K5M, KK5M and KK5UM is such that if the Motor is to be mounted in an inverted position with the foot pad at the top, or if the Motor is to be mounted on a wall or column so that the foot pad is vertical, a special Base must be used. Otherwise the Motor Case will be excessively tilted.

Caution: Stationary Motors should be mounted so that the axis of the Motor Shaft is horizontal. Operation of the Motor with the axis of the Shaft more than 10° from horizontal will result in lubrication difficulties.

Mounting Instructions for Series 56 Flange-Mounted Motors

These Motors can be mounted by either of two methods.

For Method No. 1, provide a mounting with a counter-bore which is a close fit on the small diameter pilot on the Motor Mounting Cover (65) and with four mounting bolt holes that align with the four tapped holes in the Cover. Use mounting bolts that will enter no more than 1" (25.4 mm) into the tapped holes in the Cover.

For Method No. 2, provide a mounting with a counter-bore which is a close fit on the large diameter pilot on the Motor Mounting Cover (65) and with a series of tapped holes that align with the bolt holes through the flanges on the Motor Case (1) and Motor Case Cover. Use the Motor Case Screws (68) for attaching the motor assembly to the mounting.

Always provide a bearing for the outer end of the Motor Shaft. Locate it as far from the Motor as possible and be very careful to get good alignment.

Always provide an outboard bearing for pinions or shaft extensions. They cannot be overhung from the Motor Shaft

Do not make shaft extensions a tight fit in the broached hole in the crank. An outboard bearing cannot be perfectly aligned with the crank bearings and the splined fit must act to a limited extent as a flexible coupling. Dimensions recommended for Motor Shaft splines will be furnished on receipt of mounting details and outboard bearing location. The Motor Shaft must be supported in such a manner that no end thrust will be transferred to the crank.

MAINTENANCE INSTRUCTIONS

Motor Disassembly

1. Drain the oil.
2. Remove the Motor Case (1) from the Base (45 or 46).

3. Remove one Cylinder (26) from the Motor. Rotate the Crank (10) until the Piston (21) from which the Cylinder was removed is at top dead center. Remove the Wrist Pin (24) and Piston from the Connecting Rod (17). Repeat until all Cylinders and Pistons have been removed.
4. The Crank is now held in place only by the fit of the Crank Bearing (20) in its recess and can usually be removed by pulling on it with one hand while tapping the face of the Motor Case (1) with a soft hammer. If this method fails to loosen the Bearing, remove the Rotary Valve (see paragraph 5). Insert a brass rod or hardwood arbor through the bore of the Rotary Valve Bushing (30, 77, 112 or 141) and drive on the rod until the Crank Assembly is loosened.
5. Remove the Valve Chest Cover (34, 35, 95, 125 or 149) from the Valve Chest (29, 75, 110 or 140) and withdraw the Rotary Valve (31, 33, 86, 117 or 145) with a bolt screwed into the tapped hole in the end of the Valve. Valves are tapped $\frac{5}{8}$ "-11 thread on Sizes CM, CCM, CCUM, DM, DDM, DDUM, D6M, DD6M, DD6UM, KM, KKM, KKUM, K5M, KK5M and KK5UM; $\frac{3}{4}$ "-10 thread on Sizes EM, EEM and EEUM; $\frac{7}{8}$ "-9 thread on Sizes E5M, EE5M and EE5UM; 1"-8 thread on Sizes HM, HHM and HHUM; $1\frac{1}{8}$ "-7 thread on Sizes H5M, HH5M and HH5UM.
6. Unscrew the Throttle Valve Cap (93 or 124) and remove the Poppet Throttle Valve. Withdraw the Reverse Valve with a bolt screwed into the tapped hole in the end of the Valve. Valves are tapped $\frac{5}{8}$ "-11 thread on Sizes CCUM, DDUM and DD6UM; $\frac{3}{4}$ "-10 thread on Sizes EEUM and EE5UM; $\frac{7}{8}$ "-9 thread on Sizes HHUM and HH5UM; 1"-8 thread on Sizes KKUM and KK5UM.
7. Use two Jack Bolts to remove the Valve Chest from the Motor Case. Jack Bolts may be purchased from Ingersoll-Rand or made to the dimensions shown in the following illustration.

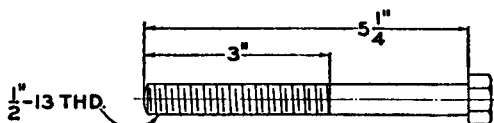

FOR C, D, D6 AND E MOTORS

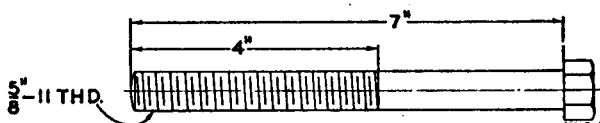

FOR H AND K MOTORS

8. Support the face of the Valve Chest that contacts the Motor Case and with a suitable arbor that will clear the Bushing Key (32, 76, 111 or 144), press the Rotary Valve Bushing (30, 77, 112 or 141) and Reverse Valve Bushing (80 or 113) from the Valve Chest.

Crank—Disassembly

1. **For any Series C, D, D6 or E Motor:** Loosen the Crank Pinch Bolt (13), straighten the split end of the Crank Taper Pin (12) and drive it out of the Crank (10).
For any Series H or K Motor: Remove the Crank Lock Pin Cotter (14), unscrew the Crank Lock Pin Nut (13) and remove the Crank Lock Pin (12) from the Crank (10).
2. Separate the two sections of the Crank and remove the Connecting Rod Rings (18), Connecting Rods (17), Connecting Rod Bushing (19) and Crank Pin Sleeve (11).
3. Pry the Crank Bearing (20) from each section of the Crank, only if replacement is necessary.

Crank—Assembly

Note: The two sections of the Crank are matched before final machining, and the web of each section is stamped with an identification mark as AA17, CC21, XX19, etc. Only sections bearing identical markings can be used together. Therefore, if two or more Cranks are disassembled at one time, check the web of each section before reassembly to make sure that only matched parts are assembled together.

1. Slide the Crank Pin Sleeve (11), **plain** end first (there is a tang one end), over the crank pin.
2. Slide the Connecting Rod Bushing (19) over the Sleeve.
3. Place one Connecting Rod Ring (18), radius end last, over the Bushing.
4. Place the Connecting Rods (17) around the Bushing, entering the foot of each Rod into the space between the Bushing and the Ring.
5. Slide the second Ring, radius end first, over the feet of the Rods.
6. Join the two sections of the Crank, so that the tang on the Crank Pin Sleeve enters the slot in the Crank web, and the holes for the Crank Taper Pin or Crank Lock Pin are aligned.
7. **On any Series H or K Motor,** insert the Crank Lock Pin (12) into the larger end of the tapered hole, apply the Crank Lock Pin Nut (13) and, after tightening the Nut securely, lock it in position with the Crank Lock Pin Cotter (14). **On any Series C, D, D6 or E Motor,** use a new Crank Taper Pin (12) each time a Crank is reassembled. Drive it into the aligned holes in the two crank sections, tighten the Crank Pinch Bolt (13) and spread the split end of the Crank Taper Pin.
8. Using a sleeve that contacts only the inner ring of the Bearing, press a Crank Bearing (20) onto each end of the Crank. Press Bearings on until the inner ring contacts the shoulder.

Motor Shaft—Removal and Replacement

1. Remove the Pulley, and on any Series C, D, D6 or E Motor remove the Shaft Key (53) and Shaft Collar (51).
2. Using a screwdriver work the Retaining Ring (50 or 53) out of the groove in the Base (45 or 46) and remove the Dust Washer (49 or 52).
3. Withdraw the Motor Shaft assembly. If the Motor has been removed, the splined end of the Shaft can be tapped lightly with a soft hammer or block of wood to loosen. On any Series H or K Motor loosen the Bearing Spacer Set Screw (50) and slide the Bearing Spacer (49) from the Motor Shaft.
4. Remove the Motor Shaft Bearing (48 or 51), only if replacement is necessary, by supporting the inner ring of the Bearing and pressing the Shaft out.
5. Remove the Oil Seal (46) used on Series H and K Motors only if replacement is necessary. The Motor must be removed so that the Seal can be driven out of the Motor side of the Base.
6. Replacement is practically a reversal of the removal procedure. Install the new Oil Seal (46) with the lip toward the Motor. Use a flat metal or wooden arbor so that the Seal will not be damaged during installation.
7. Press the Motor Shaft Bearing (48 or 51) onto the Motor Shaft (47 or 48) so that the shielded side of the Bearing faces the pulley end of the Shaft.
8. On any Series H or K Motor, slide the Bearing Spacer (49) over the splined end of the Shaft and against the inner ring of the Motor Shaft Bearing. Position the Spacer so that the set screw hole is in alignment with the indent in the Shaft, then screw the Bearing Spacer Set Screw (50) securely into place.
9. Examine the Motor end of the Spacer, determining that there are no burrs or nicks that will damage the Oil Seal. Smooth with an oil stone if necessary. Coat the surface that contacts the Seal with light grease.
10. Insert the Shaft assembly into the Base, slide the Dust Washer (49 or 52) against the Bearing and install the Retaining Ring (50 or 53).

Valve Chest—Assembly

Note: All Rotary Valve Bushings and Reverse Valve Bushings are properly sized at the factory and, if carefully installed, reaming after installation is seldom necessary.

If the Rotary Valve (31, 33, 86, 117 or 145) fits too tightly in the Rotary Valve Bushing after installation, lap it to a good running fit using a mild, fine grain compound whose abrasive agent will rapidly disintegrate.

The Reverse Valve (88 or 120) is chrome-plated and should not be lapped. If it fits too tightly in the Reverse Valve Bushing (80 or 113), ream the Bushing. The Reverse Valve diameters for the various sizes are as follows:

CCUM, DDUM, DD6UM . . . 1.375" (35 mm)
EEUM, EE5UM 1.625" (41 mm)

HHUM 1.750" (44.5 mm)
HHSUM 1.875" (47.6 mm)
KKUM, KKSUM 2.000" (50.8 mm)

1. **For Utility Hoist Type Valve Chest:** Support the face of the Valve Chest (75 or 100) that contacts the Valve Chest Cover (95 or 125), align the slot in the Reverse Valve Bushing (80 or 113) with the Bushing Key and press the Bushing in flush with the supported face of the Chest. Ream the hole through the wall of the Bushing .505" (12.8 mm) (see Maintenance Tool No. 23470). Check fit between Reverse Valve and Bushing; if too tight, ream Bushing to proper size as stated above.
2. **For all types of Valve Chest,** support the face of the Valve Chest (29, 75, 110 or 140) that contacts the Valve Chest Cover (34, 35, 95, 125 or 149), align the slot in the Rotary Valve Bushing (30, 77, 112 or 141) with the Bushing Key (32, 76, 111 or 144) and press the Bushing into the Chest. For Series H and K Motors, press in the Bushing until the shoulder near its leading face is flush with the supported face of the Chest; for all other Motors, press in the Bushing until its leading face is flush with the supported face of the Chest. Check fit between Valve and Bushing. See **Note** above if Valve is too tight in Bushing.
3. **For Shuttle Valve Chest,** press a Shuttle Valve Bushing (143) into each end of the Shuttle Valve bore, until the trailing face of each Bushing is 1¹⁵/₁₆" (49.2 mm) deep and ream them .875" (22.2 mm). (See Maintenance Tools on page 11 for Bushing Inserting Tool and Reamer). Ream through both Bushings to obtain accurate alignment.
4. **For Utility Hoist Type Valve Chest,** rotate the Reverse Valve in the Reverse Valve Bushing until the arrows on the two parts align. Insert the Throttle Valve Ball (89 or 121), Throttle Valve (90 or 122) and Throttle Valve Spring (91 or 123) into the Chest and apply the Throttle Valve Cap (93 or 124). Install the Throttle Lever Spring (103 or 130) so that its coil encircles the protruding end of the Reverse Valve Bushing and its legs straddle the Throttle Spring Stop Pin (83 or 114) which protrudes from the Chest. Install the Throttle Lever (102) of Sizes CCUM, DDUM and DD6UM, or the Throttle Control Arm (128) of other Sizes, by slipping the square socket in the Lever or Arm over the square shank on the Reverse Valve and entering the Stop Pin (101 or 129) between the spring legs.

Motor—Assembly

1. Support the open face of the Motor Case (1). Start the end of the Rotary Valve Bushing that protrudes from the Valve Chest, squarely into the Bushing bore of the Motor Case, aligning the bolt holes in the Chest with the tapped holes in the Motor Case. Press on Bushing until the Valve Chest contacts the Motor Case.
2. Install the Crank assembly in the Motor Case, seating the Crank Bearing in the recess in the Case.

3. Rotate the Crank until one of the Connecting Rods is at top dead center, place a Piston (21) on this Rod and retain it with a Wrist Pin (24).
4. Place a Cylinder Gasket (25) over the skirt and against the flange of one Cylinder (26).
5. Slide the Cylinder over the Piston and into Motor Case. **Note:** The Piston Ring (22) (compression ring near the top of the Piston) can be compressed sufficiently with the fingers to enter it into the Cylinder. It is also possible to start the Oil Regulating Ring (23) with the fingers, but it is very difficult and there is danger of breaking the Ring if it is not uniformly started in the Cylinder. It is recommended that a Piston Ring Compressor be used. One can be purchased from Ingersoll-Rand (see Maintenance Tools on page 11) or one can be made from $1/16$ " (1.6 mm) spring steel about $3/4$ " (19 mm) wide bent into circular shape of such size that it can be slipped over the Piston to hold the Ring compressed into its groove.
6. Retain the Cylinder in position with the Cylinder Cap Screws (27) using a Cylinder Cap Screw Washer (28) (copper washer) under the head of each Cap Screw. Repeat until all Cylinders are installed.
7. Align the Large Valve Drive Pin (32, 87, 118 or 146) that protrudes from the end of the Rotary Valve with the large drive hole in the Crank and insert the Valve into the Bushing, entering the Pin in the hole. **Note:** The Rotary Valve (31, 86 or 117) of Sizes E5M, EE5M and EE5UM over serial 39,500; HM, HHM and HHUM over serial 35,000; KM, KKM, KKUM, K5M, KK5M and KK5UM over serial 37,000 and H5M, HH5M and HH5UM all serials, is fitted with two Small Valve Drive Pins, in addition to the Large Valve Drive Pin. Cranks for the above Motors are drilled with two additional holes to receive the small Pins.
8. Install the Valve Chest Cover or Shuttle Valve Chest Cover.

IMPROVED PISTON AND CYLINDER CONSTRUCTION

HM, HHM, H5M and HH5M Motors have been improved by incorporating the following design and construction improvements.

A die cast aluminum **Piston** with a groove in the wall near each end of the wrist pin hole accommodates a snap ring for positive retention of the Pin. The use of the snap ring retainers eliminated the need for wrist pin caps, and dictated that the maximum length of the Wrist Pin be 3.625" (92 mm) which is approximately $1/16$ " (1.6 mm) shorter than the former Wrist Pin.

The die cast Pistons **must** be used in sets, and in combination with the new Wrist Pin.

The one-piece cast iron Cylinder, in which the head and sleeve are integral, has been superseded by a Cylinder Assembly consisting of a cast aluminum Cylinder Head and a cast iron Cylinder Sleeve. The Cylinder Assembly is completely interchangeable with the previous Cylinder and a combination can be used in a Motor. After a Cylinder Assembly has been installed either the Head or Sleeve can be replaced individually.

REPAIR PARTS

To keep costly downtime to a minimum, it is desirable to have on hand certain repair parts. To guide you in the stocking of repair parts, certain Illustration Numbers of the Repair Part List are marked with a bullet (•). We recommend that with parts so indicated, you stock one (pair or set) repair part for every four tools in service.

If the tools are being used in remote geographical areas, or are subject to unusually severe service, the items and quantities should be increased. Contact the nearest Ingersoll-Rand Company for recommendations.

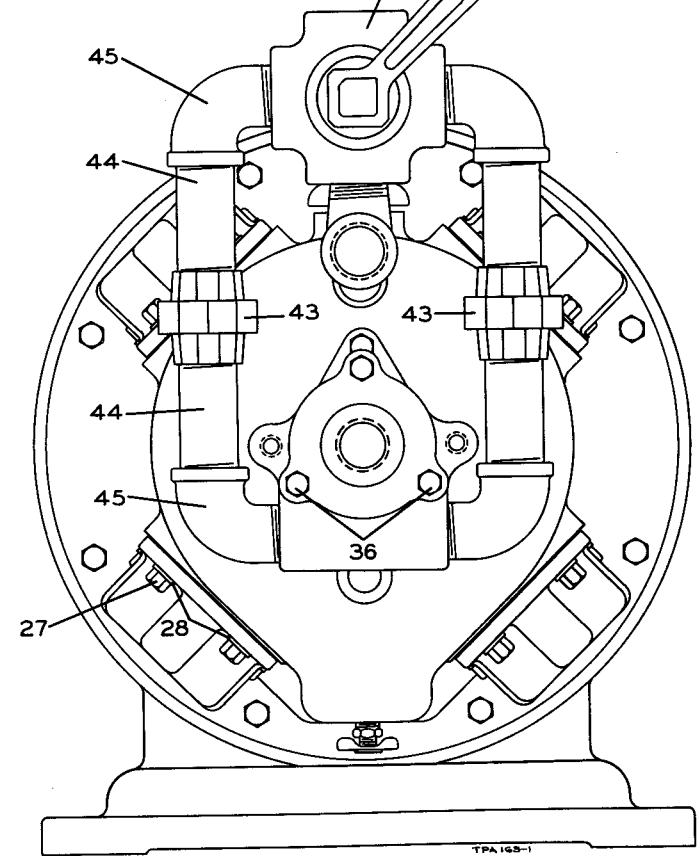
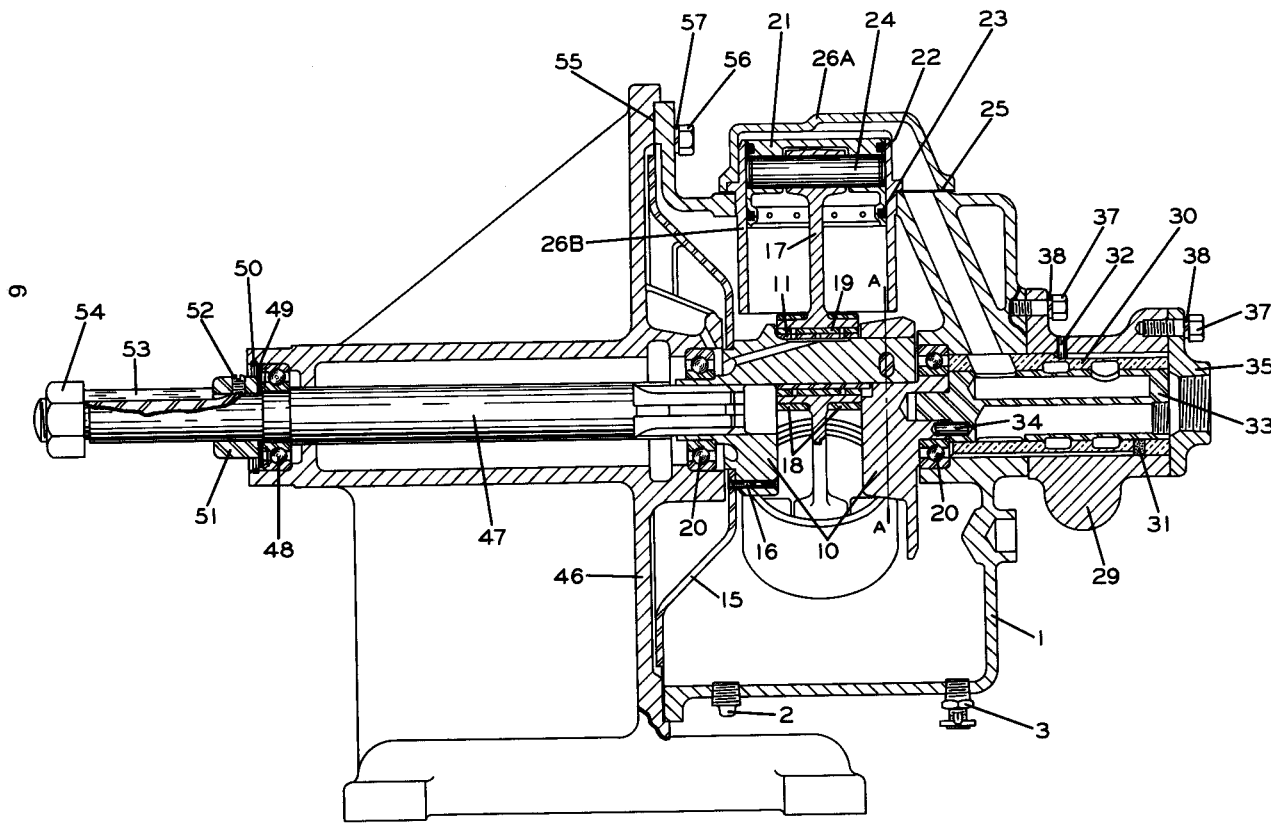
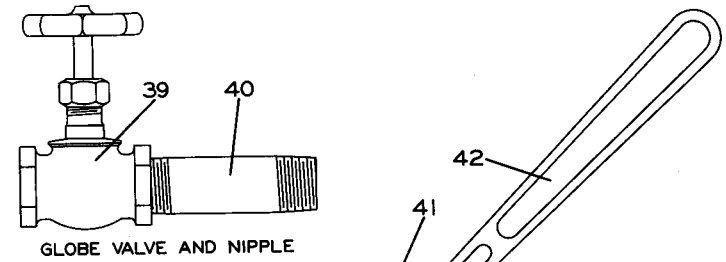
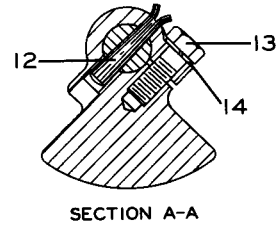
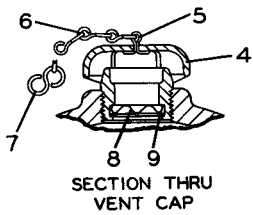

Size EEM Stationary Motor

This construction is also typical of Sizes CM, CCM, DM, DDM, D6M, DD6M, EM, E5M and EE5M

REPAIR PART LIST FOR SIZES CM, CCM, DM, DDM, D6M and DD6M STATIONARY MOTORS

Refer to illustration on page 6.

ILLUS. NUMBER (Do not use for ordering)	PART NAME FOR ORDERING (Parts indented after an item are included with that item)	PART NUMBER FOR ORDERING					
		Size CM	Size CCM	Size DM	Size DDM	Size D6M	Size DD6M
1	Motor Case	D02-501A	D02-501A	D02-501A	D02-501A	D02-501A	D02-501A
2	Drain Plug	D02-402	D02-402	D02-402	D02-402	D02-402	D02-402
3	Oil Cock (2)	D02-308	D02-308	D02-308	D02-308	D02-308	D02-308
4	Vent Cap	D02-303A	D02-303A	D02-303A	D02-303A	D02-303A	D02-303A
5	Vent Cap Cotter	D02-893	D02-893	D02-893	D02-893	D02-893	D02-893
6	Vent Cap Chain	D02-891	D02-891	D02-891	D02-891	D02-891	D02-891
7	S-Hook	D02-421	D02-421	D02-421	D02-421	D02-421	D02-421
8	Vent Cap Screen	D02-889	D02-889	D02-889	D02-889	D02-889	D02-889
9	Vent Cap Screen Retainer	6CND-233-1/2	6CND-233-1/2	6CND-233-1/2	6CND-233-1/2	6CND-233-1/2	6CND-233-1/2
	Crank Assembly	D02-A516	D02-A516	D04-A516	D04-A516	D06-A516	D06-A516
10	Crank	D02-516	D02-516	D04-516	D04-516	D06-516	D06-516
11	Crank Pin Sleeve	D02-519	D02-519	D02-519	D02-519	D02-519	D02-519
12	Crank Taper Pin	D02-520	D02-520	D02-520	D02-520	D02-520	D02-520
13	Crank Pinch Bolt	D02-521	D02-521	D02-521	D02-521	D02-521	D02-521
14	Crank Pinch Bolt Lock Washer	D02-537	D02-537	D02-537	D02-537	D02-537	D02-537
15	Oil Splasher	D02-540	D02-540	D04-540	D04-540	D04-540	D04-540
○ 16	Oil Splasher Rivet (3)	D02-541	D02-541	D02-541	D02-541	D06-541	D06-541
*	Counterweight Rivet (2)	- - -	- - -	- - -	- - -	D06-554	D06-554
*	Crank Counterweight	- - -	- - -	- - -	- - -	D06-515	D06-515
*	Counterweight Rivet (2)	- - -	- - -	- - -	- - -	D06-554	D06-554
16	Oil Splasher Rivet (3)	- - -	- - -	- - -	- - -	D06-541	D06-541
17	Connecting Rod (4)	D02-509	D02-509	D04-509	D04-509	D04-509	D04-509
18	Connecting Rod Ring (2)	D02-510	D02-510	D02-510	D02-510	D02-510	D02-510
● 19	Connecting Rod Bushing	D02-511	D02-511	D02-511	D02-511	D02-511	D02-511
● 20	Crank Bearing (2) (AFBMA No. 30BC02)	TA-22	TA-22	TA-22	TA-22	TA-22	TA-22
★ 21	Piston (4)	D02-513C	D02-513C	D6H60A-A513A	D6H60A-A513A	D06-513A	D06-513A
● 22	Piston Ring (4)	D02-337A	D02-337A	D04-337A	D04-337A	D06-337	D06-337
● 23	Oil Regulating Piston Ring (4)	D02-338	D02-338	D04-338	D04-338	D06-338	D06-338
24	Piston Wrist Pin (4)	D02-514A	D02-514A	D04-514A	D04-514A	D06-514	D06-514
*	Wrist Pin Retaining Ring (8)	R3820-340	R3820-340	R3820-340	R3820-340	- - -	- - -
● 25	Cylinder Gasket (4)	D02-507	D02-507	D02-507	D02-507	D02-507	D02-507
26	Cylinder (4)	D02-505	D02-505	D04-505	D04-505	D06-505	D06-505
27	Cylinder Cap Screw (16)	D02-506	D02-506	D02-506	D02-506	D02-506	D02-506
28	Cylinder Cap Screw Washer (16)	D02-504	D02-504	D02-504	D02-504	D02-504	D02-504
29	Valve Chest	C04-545	C04-545	C04-545	C04-545	C04-545	C04-545
30	Rotary Valve Bushing	D02-525AS	D02-525AS	D02-525AS	D02-525AS	D02-525AS	D02-525AS
31	Rotary Valve Oiler	JA4-75	JA4-75	JA4-75	JA4-75	JA4-75	JA4-75
32	Rotary Valve Bushing Key	D02-538	D02-538	D02-538	D02-538	D02-538	D02-538

* Not illustrated.

○ When ordering an Oil Splasher, also order Oil Splasher Rivets and Counterweight Rivets as required.

**REPAIR PART LIST FOR SIZES CM, CCM, DM, DDM, D6M AND
DD6M STATIONARY MOTORS (CONTINUED)**
Refer to illustration on page 6.

ILLUS. NUMBER (Do not use for ordering)	PART NAME FOR ORDERING (Parts indented after an item are included with that item)	PART NUMBER FOR ORDERING					
		Size CM	Size CCM	Size DM	Size DDM	Size D6M	Size DD6M
33	Rotary Valve for counterclockwise rotation when facing the Motor Shaft	CM-526	- - - -	CM-526	- - - -	CM-526	- - - -
	for clockwise rotation when facing the Motor Shaft. . .	CM-526R	- - - -	CM-526R	- - - -	CM-526R	- - - -
	for equal power either direction (standard).	- - - -	CCM-526	- - - -	CCM-526	- - - -	CCM-526
	for maximum power counterclockwise, when facing the Motor Shaft	- - - -	D02-526	- - - -	D02-526	- - - -	D02-526
	for maximum power clockwise, when facing the Motor Shaft	- - - -	CCM-503	- - - -	CCM-503	- - - -	CCM-503
34	Valve Drive Pin.	D02-527	D02-527	D02-527	D02-527	D02-527	D02-527
35	Valve Chest Cover.	C04-546	C04-546	C04-546	C04-546	C04-546	C04-546
36	Valve Chest Long Screw (2)	D02-548	D02-548	D02-548	D02-548	D02-548	D02-548
37	Valve Chest Short Screw (2)	D02-506	D02-506	D02-506	D02-506	D02-506	D02-506
38	3/8" Lock Washer (4)	D02-321	D02-321	D02-321	D02-321	D02-321	D02-321
39	Globe Valve	C10-283	- - - -	C10-283	- - - -	C10-283	- - - -
40	Globe Valve Nipple (3/4" x 4" long)	C04-285	- - - -	C04-285	- - - -	C04-285	- - - -
41	Air Valve.	- - - -	C04-291	- - - -	C04-291	- - - -	C04-291
42	Air Valve Lever	- - - -	C04-278	- - - -	C04-278	- - - -	C04-278
43	Union (2).	- - - -	C04-282	- - - -	C04-282	- - - -	C04-282
44	Nipple (4) (3/4" x 2 1/2" long)	- - - -	C04-286	- - - -	C04-286	- - - -	C04-286
45	3/4" Street Elbow (2)	- - - -	DU-581	- - - -	DU-581	- - - -	DU-581
*	3/4" 90° Elbow (2)	- - - -	P25-198	- - - -	P25-198	- - - -	P25-198
*	3/4" Close Nipple (1 3/8" long) (2).	- - - -	J3-840	- - - -	J3-840	- - - -	J3-840
46	Base.	C04-292A	C04-292A	C04-292A	C04-292A	C04-292A	C04-292A
47	Motor Shaft	C04-294A	C04-294A	C04-294A	C04-294A	C04-294A	C04-294A
48	Motor Shaft Bearing (AFBMA No. 30BC02JP)	C04-318	C04-318	C04-318	C04-318	C04-318	C04-318
● 49	Dust Washer	EEG-770	EEG-770	EEG-770	EEG-770	EEG-770	EEG-770
50	Retaining Ring	D10-340	D10-340	D10-340	D10-340	D10-340	D10-340
51	Shaft Collar	C04-30	C04-30	C04-30	C04-30	C04-30	C04-30
52	Shaft Collar Set Screw.	C04-31	C04-31	C04-31	C04-31	C04-31	C04-31
53	Shaft Key.	E3G-758	E3G-758	E3G-758	E3G-758	E3G-758	E3G-758
54	Shaft Nut	C04-289A	C04-289A	C04-289A	C04-289A	C04-289A	C04-289A
● 55	Motor Case Cover Gasket	D02-592	D02-592	D02-592	D02-592	D02-592	D02-592
56	Motor Case Screw (8)	D02-354	D02-354	D02-354	D02-354	D02-354	D02-354
57	3/8" Lock Washer (8)	D02-321	D02-321	D02-321	D02-321	D02-321	D02-321

* Not illustrated.

★ If the Piston being replaced in a Size CM or CCM Motor is cast iron or a superseded style aluminum Piston, order and install a complete set of Pistons, Wrist Pins and Wrist Pin Retainers. No. D02-513C Piston is aluminum and has a groove on each end of the Wrist pin bore while the superseded style does not. Do not use a new style Piston in combination with either superseded style Piston.

REPAIR PART LIST FOR SIZES EM, EEM, E5M and EE5M STATIONARY MOTORS
Refer to illustration on page 6.

ILLUS. NUMBER (Do not use for ordering)	PART NAME FOR ORDERING (Parts indented after an item are included with that item)	PART NUMBER FOR ORDERING			
		Size EM	Size EEM	Size E5M	Size EE5M
1	Motor Case	D10-501	D10-501	E5UD-501	E5UD-501
2	Drain Plug	D02-402	D02-402	T1SE-368	T1SE-368
3	Oil Cock (2)	D02-308	D02-308	D02-308	D02-308
4	Vent Cap.	D02-303A	D02-303A	D02-303A	D02-303A
5	Vent Cap Cotter	D02-893	D02-893	D02-893	D02-893
6	Vent Cap Chain	D02-891	D02-891	D02-891	D02-891
7	S-Hook	D02-421	D02-421	D02-421	D02-421
8	Vent Cap Screen	D02-889	D02-889	D02-889	D02-889
9	Vent Cap Screen Retainer	6CND-233-1/2	6CND-233-1/2	6CND-233-1/2	6CND-233-1/2
*	1 1/4" Pipe Plug	- - - -	- - - -	E5UD-947	E5UD-947
	Crank Assembly	D10-A516	D10-A516	E5M-A516	E5M-A516
10	Crank	D10-516	D10-516	D10-516	D10-516
11	Crank Pin Sleeve	D10-519	D10-519	D10-519	D10-519
12	Crank Taper Pin	D10-520	D10-520	D10-520	D10-520
13	Crank Pinch Bolt.	D10-521	D10-521	D10-521	D10-521
14	Crank Pinch Bolt Lock Washer.	D10-322	D10-322	D10-322	D10-322
15	Oil Splasher.	D10-540	D10-540	D10-540	D10-540
16	Oil Splasher Rivet (4)	D06-541	D06-541	D06-541	D06-541
17	Connecting Rod (1 for each Piston)	D10-509	D10-509	E5UD-509	E5UD-509
18	Connecting Rod Ring (2)	D10-510	D10-510	D10-510	D10-510
● 19	Connecting Rod Bushing	D10-511	D10-511	D10-511	D10-511
20	Crank Bearing (2) (AFBMA No. 35BC02)	D10-518	D10-518	D10-518	D10-518
21	Piston (1 for each Cylinder)	D10-513	D10-513	D10-513	D10-513
● 22	Piston Ring (1 for each Piston)	D10-337A	D10-337A	D10-337A	D10-337A
● 23	Oil Regulating Piston Ring (1 for each Piston)	D10-338	D10-338	D10-338	D10-338
24	Piston Wrist Pin (1 for each Piston)	D10-514	D10-514	D10-514	D10-514
● 25	Cylinder Gasket (1 for each Cylinder)	D10-507	D10-507	D10-507	D10-507
26	Cylinder (4 for EM and EEM; 5 for E5M and EE5M)	D10-505	D10-505	E5UD-505	E5UD-505
27	Cylinder Cap Screw (4 for each Cylinder)	D10-506	D10-506	D10-506	D10-506
28	Cylinder Cap Screw Washer (4 for each Cylinder)	D10-504	D10-504	D10-504	D10-504
29	Valve Chest	C10-545	C10-545	E5M-545	E5M-545
30	Rotary Valve Bushing	D10-525AS	D10-525AS	E5UD-525AS	E5UD-525AS
31	Rotary Valve Oiler.	JA4-75	JA4-75	- - - -	- - - -
32	Rotary Valve Bushing Key	B12-255	B12-255	B12-255	B12-255

* Not illustrated.

REPAIR PART LIST FOR SIZES EM, EEM, E5M and EE5M STATIONARY MOTORS (Cont'd)
Refer to illustration on page 6.

ILLUS. NUMBER (Do not use for ordering)	PART NAME FOR ORDERING (Parts indented after an item are included with that item)	PART NUMBER FOR ORDERING			
		Size EM	Size EEM	Size E5M	Size EE5M
33	Rotary Valve For counterclockwise rotation when facing the Motor Shaft For clockwise rotation when facing the Motor Shaft For equal power either direction (standard) For maximum power counterclockwise, when facing the Motor Shaft For maximum power clockwise when facing the Motor Shaft	EM-526 EM-526R - - - - - - - - - - - -	- - - - - - - - EEG-526 D10-526 D20-526	E5M-526A E5M-526RA - - - - - - - - - - - -	- - - - - - - - EE5M-526A D10-526-5 EEUD-526A
34	Large Valve Drive Pin	D10-527	D10-527	D10-527	D10-527
*	Small Valve Drive Pin (2)	- - - -	- - - -	D02-527	D02-527
35	Valve Chest Cover	C10-546	C10-546	C10-546	C10-546
36	Valve Chest Long Screw (2)	D10-548	D10-548	D10-548	D10-548
37	Valve Chest Short Screw (2)	D02-506	D02-506	D02-506	D02-506
38	3/8" Lock Washer (4)	D02-321	D02-321	D02-321	D02-321
39	Globe Valve	C10-283	- - - -	HM-283	- - - -
40	Globe Valve Nipple	C04-285	- - - -	HM-285	- - - -
*	Reducing Bushing	C10-284	- - - -	- - - -	- - - -
41	Air Valve	- - - -	C10-291	- - - -	C10-291
42	Air Valve Lever	- - - -	C10-278	- - - -	C10-278
43	Union (2)	- - - -	C10-282	- - - -	C10-282
44	Nipple (4) (1" x 3 1/2" long)	- - - -	C10-286	- - - -	C10-286
45	1" Street Elbow (5)	- - - -	DU-587	- - - -	DU-587
46	Base	C10-292A	C10-292A	C10-292A	C10-292A
47	Motor Shaft	C10-294A	C10-294A	C10-294A	C10-294A
● 48	Motor Shaft Bearing (AFBMA No. 30BC02JP)	C04-318	C04-318	C04-318	C04-318
49	Dust Washer	EEG-770	EEG-770	EEG-770	EEG-770
50	Retaining Ring	D10-340	D10-340	D10-340	D10-340
51	Shaft Collar	C04-30	C04-30	C04-30	C04-30
52	Shaft Collar Set Screw	C04-31	C04-31	C04-31	C04-31
53	Shaft Key	E3G-758	E3G-758	E3G-758	E3G-758
54	Shaft Nut	C04-289A	C04-289A	C04-289A	C04-289A
55	Motor Case Cover Gasket	D10-592	D10-592	D10-592	D10-592
56	Motor Case Screw (8)	D02-354	D02-354	D02-354	D02-354
57	3/8" Lock Washer (8)	D02-321	D02-321	D02-321	D02-321

* Not illustrated.

**AIR STRAINER ASSEMBLY FOR
SIZES EEM, E5M, EE5M, HM, HHM, H5M, HH5M, KM, KKM, K5M and KK5M MOTORS
and HH5M STATIONARY MOTORS**

ILLUS. NUMBER (Do not use for ordering)	PART NAME FOR ORDERING (Parts indented after an item are included with that item)	PART NUMBER FOR ORDERING	
		Sizes EEM, E5M, EE5M, HM, HHM	Sizes H5M, HH5M, KM, KKM, K5M, KK5M
400	Air Strainer Assembly.	HU-A267AT	K4U-A267AT
401	Air Strainer Screen	HU-61AT	K4U-61AT
403	Air Strainer Plug	D02-351	22SR-165
404	Air Strainer Cap	HU-268AT	K4U-268AT
*	Air Strainer Nipple	HHM-286	KKM-286

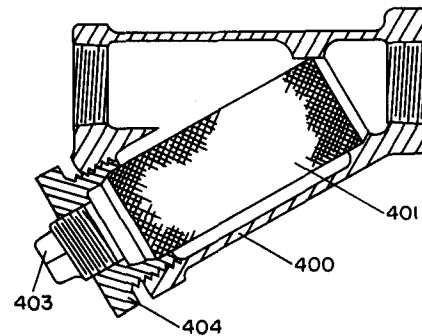

* Not illustrated.

MAINTENANCE TOOLS

TOOL NUMBER FOR ORDERING	TOOL NAME FOR ORDERING	OPERATION
P25-228	Grease Gun	Lubrication.
D02-932	Valve Chest Jack Bolt (2)	Removing the Valve Chest (29, 75 and 140) from the Motor Case (1) on CM, DM, D6M and EM Series Motors.
HU-932	Valve Chest Jack Bolt (2)	Removing the Valve Chest (29 and 110) from the Motor Case (1) on HM and KM Series Motors.
D02-933	Piston Ring Compressor	Compressing the Piston Rings (22 and 23) when installing a Cylinder (26) on CM Series Motors.
D04-933	Piston Ring Compressor	Compressing the Piston Rings (22 and 23) when installing a Cylinder (26) on DM Series Motors.
D06-933	Piston Ring Compressor	Compressing the Piston Rings (22 and 23) when installing a Cylinder (26) on D6M Series Motors.
D10-933	Piston Ring Compressor	Compressing the Piston Rings (22 and 23) when installing a Cylinder (26) on EM Series Motors.
HU-933	Piston Ring Compressor	Compressing the Piston Rings (22 and 23) when installing a Cylinder (26) on HM Series Motors.
KU-933	Piston Ring Compressor	Compressing the Piston Rings (22 and 23) when installing a Cylinder (26) on KM Series Motors.
23468	Throttle Valve Seat Reamer	Refacing the seat in the Valve Chest (75) for the Poppet Throttle Valve (90).
23470	Throttle Valve Stem Reamer	Reaming the throttle valve stem hole in the Reverse Valve Bushings (80 and 113) after installing a new Bushing.
25670	Throttle Valve Seat Reamer	Refacing the seat in the Valve Chest (110) for the Poppet Throttle Valve (122) on Sizes HH5UM, KKUM and KK5UM.
25673	Throttle Valve Seat Reamer	Refacing the seat in the Valve Chest (110) for the Poppet Throttle Valve (122) on Size HHUM.
37860	Shuttle Valve Bushing Reamer	Hand reaming the Shuttle Valve Bushing (143) after installation.
37871	Shuttle Valve Bushing Inserting Tool	Installing the Shuttle Valve Bushing (143) in the Shuttle Valve Chest (140).

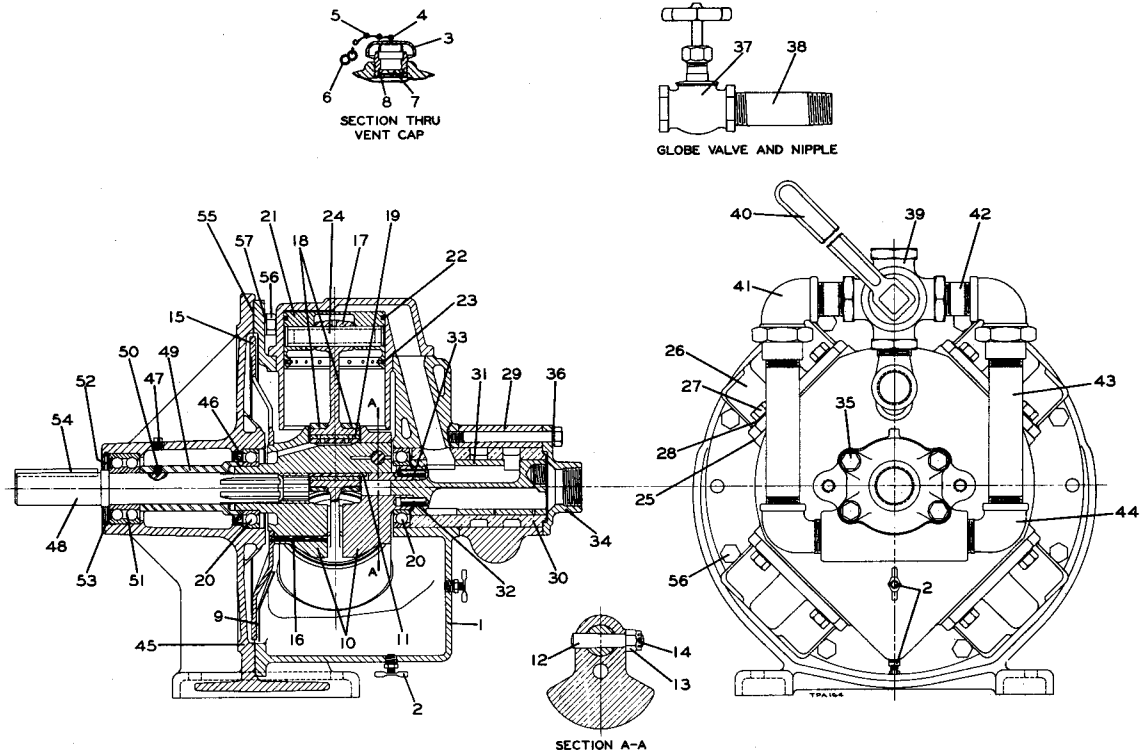

Size KKM Stationary Motor

This construction also typical of Sizes HM, HHM, H5M, HH5M, KM, K5M and KK5M

REPAIR PART LIST FOR SIZES HM, HHM, H5M and HH5M STATIONARY MOTORS

Refer to illustration above.

ILLUS. NUMBER (Do not use for ordering)	PART NAME FOR ORDERING (Parts indented after an item are included with that item)	PART NUMBER FOR ORDERING			
		Size HM	Size HHM	Size H5M	Size HH5M
1	Motor Case	HU-501	HU-501	HH5D-501	HH5D-501
2	Oil Cock (2)	D02-308	D02-308	D02-308	D02-308
3	Vent Cap	D02-303A	D02-303A	D02-303A	D02-303A
4	Vent Cap Cotter	D02-893	D02-893	D02-893	D02-893
5	Vent Cap Chain	D02-891	D02-891	D02-891	D02-891
6	S-Hook	D02-421	D02-421	D02-421	D02-421
7	Vent Cap Screen	D02-889	D02-889	D02-889	D02-889
8	Vent Cap Screen Retainer	6CND-233-1/2	6CND-233-1/2	6CND-233-1/2	6CND-233-1/2
*	1 1/4" Pipe Plug	- - - -	- - - -	ESUD-947	ESUD-947
†	3/8" Pipe Plug	TISE-368	TISE-368	TISE-368	TISE-368
	Crank Assembly	HM-A516	HM-A516	H5M-A516	H5M-A516
10	Crank	HU-516	HU-516	HU-516	HU-516
11	Crank Pin Sleeve	HU-519	HU-519	HU-519	HU-519
12	Crank Lock Pin	HU-520	HU-520	HU-520	HU-520
13	Crank Lock Pin Nut	D02-394	D02-394	D02-394	D02-394
14	Crank Lock Pin Cotter	D02-524	D02-524	D02-524	D02-524
15	Oil Splasher	HU-540	HU-540	HU-540	HU-540
16	Oil Splasher Long Rivet (2)	HU-541	HU-541	HU-541	HU-541
*	Oil Splasher Short Rivet (2)	HU-542	HU-542	HU-542	HU-542
17	Connecting Rod (1 for each Piston)	HU-509	HU-509	HH5D-509	HH5D-509
18	Connecting Rod Ring (2)	HU-510	HU-510	HU-510	HU-510
● 19	Connecting Rod Bushing	HU-511	HU-511	HU-511	HU-511
● 20	Crank Bearing (2) (AFBMA No. 40BL02)	HU-518	HU-518	HU-518	HU-518
21	Piston Assembly (1 for each Cylinder) See *	HU-A513B	HU-A513B	HU-A513B	HU-A513B
● 22	Piston Ring (1 for each Piston)	HU-337	HU-337	HU-337	HU-337
● 23	Oil Regulating Piston Ring (1 for each Piston)	HU-338	HU-338	HU-338	HU-338
*	Retaining Ring (2 for each Piston)	902A45-632	902A45-632	902A45-632	902A45-632

* Not illustrated.

† Use discontinued on H5M and HH5M. Still available if required for older Motors.

REPAIR PART LIST FOR SIZES HM, HHM, H5M and HH5M STATIONARY MOTORS (Cont'd)

Refer to illustration on page 12.

ILLUS. NUMBER (Do not use for ordering)	PART NAME FOR ORDERING (Parts indented after an item are included with that item)	PART NUMBER FOR ORDERING			
		Size HM	Size HHM	Size H5M	Size HH5M
24	Piston Wrist Pin (1 for each Piston) See ★	HU-514A	HU-514A	HU-514A	HU-514A
• 25	Cylinder Gasket (1 for each Cylinder)	HU-507	HU-507	HU-507	HU-507
26	Cylinder Assembly (4 for HM or HHM; 5 for H5M or HH5M) See ★				
	Cylinder Head	HH5D-A505A	HH5D-A505A	HH5D-A505A	HH5D-A505A
	Cylinder Sleeve	HH5D-H505A	HH5D-H505A	HH5D-H505A	HH5D-H505A
	Cylinder L505A	HH5D-L505A	HH5D-L505A	HH5D-L505A	HH5D-L505A
27	Cylinder Cap Screw (4 for each Cylinder)	D10-354	D10-354	D10-354	D10-354
28	Cylinder Cap Screw Washer (4 for each Cylinder)	HU-504	HU-504	HU-540	HU-540
29	Valve Chest	HX-545	HX-545	H5M-545	H5M-545
30	Rotary Valve Bushing	HU-525S	HU-525S	HH5D-525S	HH5D-525S
* 31	Rotary Valve Bushing Key	HU-538	HU-538	HU-538	HU-538
	Rotary Valve				
	for continuous slow speed or intermittent high speed running, counterclockwise rotation	HM-526	----	H5M-526	----
	for continuous high speed running, counterclockwise rotation	----	----	H5M-H526	----
	for continuous slow speed or inter- mittent high speed running, clockwise rotation	HM-526R	----	H5M-526R	----
	for continuous high speed running, clockwise rotation	----	----	H5M-H526R	----
	for continuous slow speed or intermittent high speed running, equal power in either direction of rotation	----	HHM-526A	----	HH5M-526
	for continuous high speed running, equal power in either direction of rotation	----	----	----	HH5M-H526
	for continuous high speed running, maximum power in clockwise rotation	----	----	----	HH5M-H526R
	for intermittent low speed running, equal power in either direction of rotation	----	----	----	HH5M-L526
	for continuous low speed or intermittent high speed running, maximum power in counterclockwise rotation	----	HU-526A	----	H5U-526
	for continuous low speed or intermittent high speed running, maximum power in clockwise rotation	----	HU-526RA	----	H5U-526R
32	Large Valve Drive Pin	HU-527	HU-527	HU-527	HU-527
33	Small Valve Drive Pin (2)	HU-627	HU-627	HU-627	HU-627
34	Valve Chest Cover	HX-546	HX-546	HX-546	HX-546
35	Valve Chest Screw (4)	HU-548	HU-548	HU-548	HU-548
36	3/8" Lock Washer (4)	D02-321	D02-321	D02-321	D02-321
37	Globe Valve	HM-283	----	KM-283	----
38	Globe Valve Nipple	HM-285	----	KM-285	----
39	Air Valve	----	C10-291	----	KKM-A291B
40	Air Valve Lever	----	C10-278	----	KKM-278B
41	Union Elbow (2)	----	HX-282	----	KX-282
42	Short Nipple (2)	----	HHM-286	----	KK6M-288
43	Long Nipple (2)	----	HHM-287	----	KK6M-287
44	Street Elbow (3)	----	DU-587	----	KX-587
45	Base	HM-292	HM-292	H5M-292	H5M-292
46	Oil Seal	HM-270	HM-270	HM-270	HM-270
47	Grease Plug	D02-351	D02-351	D02-351	D02-351
48	Motor Shaft	HM-294	HM-294	HM-294	HM-294
49	Bearing Spacer	HM-41	HM-41	HM-41	HM-41
50	Bearing Spacer Set Screw	C04-31	C04-31	C04-31	C04-31
• 51	Motor Shaft Bearing (AFBMA No. 35BL03JP)	E3G-763	E3G-763	E3G-763	E3G-763
52	Dust Washer	HM-298	HM-298	HM-298	HM-298
53	Retaining Ring	HM-295	HM-295	HM-295	HM-295
54	Shaft Key	E9G-758	E9G-758	E9G-758	E9G-758
55	Motor Case Cover Gasket	HU-592	HJ-592	HH5D-592	HH5D-592
56	Motor Case Screw (8 for HM and H5M; 10 for HHM and HH5M)	215-148	215-148	215-148	215-148
57	1/2" Lock Washer (8 for HM and H5M; 10 for HHM and HH5M)	D10-322	D10-322	D10-322	D10-322

* Not illustrated.

★ Refer to IMPROVED PISTON and CYLINDER CONSTRUCTION on page 5.

REPAIR PART LIST FOR SIZES KM, KKM, K5M and KK5M STATIONARY MOTORS

Refer to illustration on page 12.

ILLUS. NUMBER (Do not use for ordering)	PART NAME FOR ORDERING (Parts indented after an item are included with that item)	PART NUMBER FOR ORDERING			
		Size KM	Size KKM	Size K5M	Size KK5M
1	Motor Case	KU-501	KU-501	K5M-501	K5M-501
2	Oil Cock (2)	D02-308	D02-308	D02-308	D02-308
3	Vent Cap	D02-303A	D02-303A	D02-303A	D02-303A
4	Vent Cap Cotter	D02-893	D02-893	D02-893	D02-893
5	Vent Cap Chain	D02-891	D02-891	D02-891	D02-891
6	S-Hook	D02-421	D02-421	D02-421	D02-421
7	Vent Cap Screen	D02-889	D02-889	D02-889	D02-889
8	Vent Cap Screen Retainer	6CND-233-1/2	6CND-233-1/2	6CND-233-1/2	6CND-233-1/2
9	Oil Baffle	KU-543	KU-543	KU-543	KU-543
*	Oil Baffle Drive Screw (8)	R4K-302	R4K-302	R4K-302	R4K-302
*	Motor Eye Bolt (1 for KM and KKM; 2 for K5M and KK5M)	KU-888	KU-888	KU-888	KU-888
*	1 1/4" Pipe Plug	- - - -	- - - -	E5UD-947	E5UD-947
	Crank Assembly	KM-A516	KM-A516	K5M-A516	K5M-A516
10	Crank	KU-516	KU-516	KU-516	KU-516
11	Crank Pin Sleeve	KU-519	KU-519	KU-519	KU-519
12	Crank Lock Pin	KU-520	KU-520	KU-520	KU-520
13	Crank Lock Pin Nut	D02-317	D02-317	D02-317	D02-317
14	Crank Lock Pin Cotter	D02-330	D02-330	D02-330	D02-330
15	Oil Splasher	KU-540	KU-540	KU-540	KU-540
16	Oil Splasher Long Rivet (2)	KU-541	KU-541	KU-541	KU-541
*	Oil Splasher Short Rivet (2)	KU-542	KU-542	KU-542	KU-542
17	Connecting Rod (1 for each Piston)	KU-509	KU-509	K5M-509	K5M-509
18	Connecting Rod Ring (2)	KU-510	KU-510	KU-510	KU-510
19	Connecting Rod Bushing	KU-511	KU-511	KU-511	KU-511
20	Crank Bearing (2) (AFBMA No. 55BC02)	KU-518	KU-518	KU-518	KU-518
21	Piston (1 for each Cylinder)	KU-513	KU-513	KU-513	KU-513
22	Piston Ring (1 for each Piston)	KU-337	KU-337	KU-337	KU-337
23	Oil Regulating Piston Ring (1 for each Piston)	KU-338	KU-338	KU-338	KU-338
24	Piston Wrist Pin (1 for each Piston)	KU-514	KU-514	KU-514	KU-514
25	Cylinder Gasket (1 for each Cylinder)	KU-507	KU-507	KU-507	KU-507
26	Cylinder (4 for KM and KKM; 5 for K5M and KK5M)	KU-505	KU-505	K5M-505	K5M-505
27	Cylinder Cap Screw (4 for each Cylinder)	215-13	215-13	215-13	215-13
28	Cylinder Cap Screw Washer (4 for each Cylinder)	KU-504	KU-504	KU-504	KU-504
29	Valve Chest	KX-545	KX-545	K5M-545	K5M-545
30	Rotary Valve Bushing	KU-525S	KU-525S	K5M-525S	K5M-525S
*	Rotary Valve Bushing Key	HU-538	HU-538	HU-538	HU-538
31	Rotary Valve For counterclockwise rotation when facing the Motor Shaft	KM-526	- - - -	KM-526	- - - -
	For clockwise rotation when facing the Motor Shaft	KM-526R	- - - -	KM-526R	- - - -
	For equal power either direction (standard)	- - - -	KKM-526A	- - - -	KKM-526A
	For maximum power counterclockwise when facing the Motor Shaft	- - - -	KU-526A	- - - -	KU-526A
	For maximum power clockwise when facing the Motor Shaft	- - - -	KU-526RA	- - - -	KU-526RA
32	Large Valve Drive Pin	KU-527	KU-527	KU-527	KU-527
33	Small Valve Drive Pin (2)	HU-527	HU-527	HU-527	HU-527
34	Valve Chest Cover	KX-546	KX-546	KX-546	KX-546
35	Valve Chest Screw (4)	KU-548	KU-548	KU-548	KU-548
36	1/2" Lock Washer (4)	D10-322	D10-322	D10-322	D10-322
37	Globe Valve	KM-283	- - - -	KM-283	- - - -
38	Globe Valve Nipple	KM-285	- - - -	KM-285	- - - -
39	Air Valve	- - - -	KKM-A291B	- - - -	KKM-A291B
40	Air Valve Lever	- - - -	KKM-278B	- - - -	KKM-278B
41	Union Elbow (2)	- - - -	KX-282	- - - -	KX-282

* Not illustrated.

REPAIR PART LIST FOR SIZES KM, KKM, K5M and KK5M STATIONARY MOTORS (Cont'd)
 Refer to illustration on page 12.

ILLUS. NUMBER (Do not use for ordering)	PART NAME FOR ORDERING (Parts indented after an item are included with that item)	PART NUMBER FOR ORDERING			
		Size KM	Size KKM	Size K5M	Size KK5M
42	Short Nipple (2) (1 1/4" x 2" long)	- - - -	KK6M-288	- - - -	KK6M-288
43	Long Nipple (2) (1 1/4" x 8" long).	- - - -	KKM-287	- - - -	KKM-287
44	1 1/4" Street Elbow (3)	- - - -	KX-587	- - - -	KX-587
45	Base.	KM-292A	KM-292A	K5M-292	K5M-292
46	Oil Seal	KM-270	KM-270	KM-270	KM-270
47	Grease Plug	D02-351	D02-351	D02-351	D02-351
48	Motor Shaft	KM-294A	KM-294A	KM-294A	KM-294A
49	Bearing Spacer.	KM-41	KM-41	KM-41	KM-41
50	Bearing Spacer Set Screw	C04-31	C04-31	C04-31	C04-31
● 51	Motor Shaft Bearing (AFBMA No. 40BD056JP)	D10-825	D10-825	D10-825	D10-825
52	Dust Washer	KM-298A	KM-298A	KM-298A	KM-298A
53	Retaining Ring	KM-295	KM-295	KM-295	KM-295
54	Shaft Key	D04-323	D04-323	D04-323	D04-323
55	Motor Case Cover Gasket	KU-592	KU-592	K5M-592	K5M-592
56	Motor Case Screw (8 for KM and KKM; 10 for K5M and KK5M)	215-36	215-36	215-36	215-36
57	5/8" Lock Washer (8 for KM and KKM; 10 for K5M and KK5M)	A-67	A-67	A-67	A-67

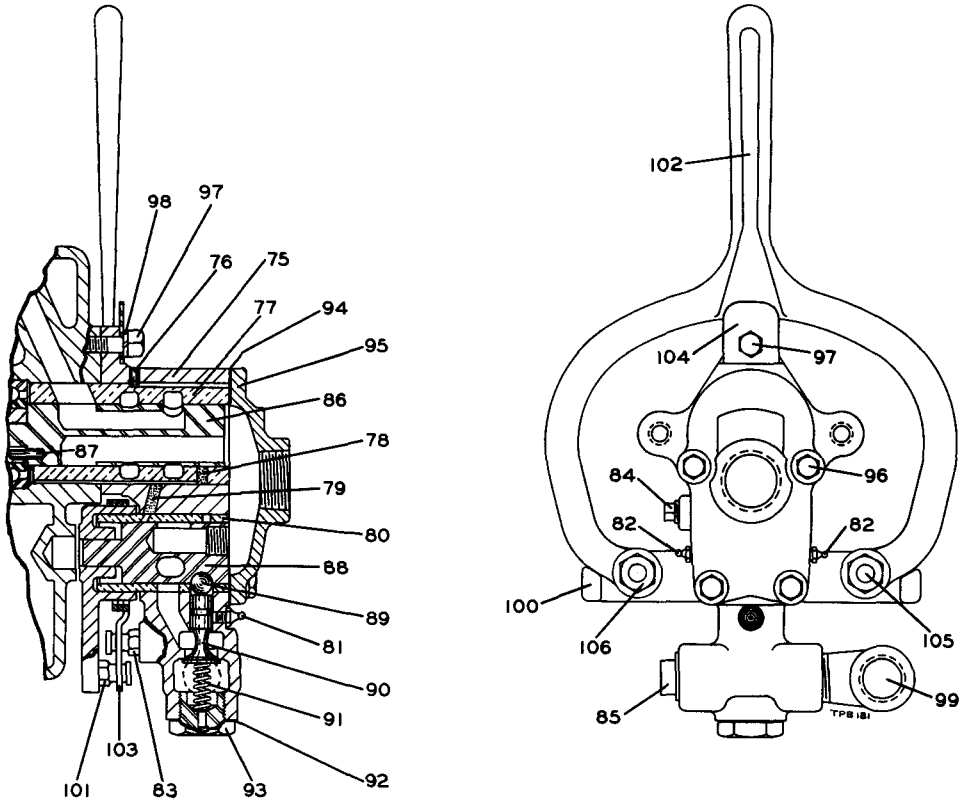

Utility Type Valve Chest for Sizes CCUM, DDUM, DD6UM, EEUM and EE5UM

**REPAIR PART LIST FOR
UTILITY TYPE VALVE CHEST SIZES CCUM, DDUM, DD6UM, EEUM and EE5UM
Refer to illustration on page 15.**

ILLUS. NUMBER (Do not use for ordering)	PART NAME FOR ORDERING (Parts indented after an item are included with that item)	PART NUMBER FOR ORDERING		
		Sizes CCUM, DDUM, DD6UM	Size EEUM	Size EE5UM
○	Valve Chest Assembly	CCUM-A545	EEUM-A545	EE5UM-A545
75	Valve Chest	D02-545A	D10-545A	D10-545-5
76	Bushing Key (2)	D02-538	B12-255	B12-255
77	Rotary Valve Bushing	D02-525A	D10-525A	E5UD-525A
78	Valve Oiler	JA4-75	JA4-75	- - - -
79	Valve Oiler	JA4-75	JA4-75	- - - -
80	Reverse Valve Bushing	D02-945S	D10-945S	D10-945-5S
81	Grease Fitting	R1-188	R1-188	R1-188
82	Grease Fitting (2)	- - - -	23-188	23-188
83	Throttle Spring Stop Pin	D02-553	D02-553	D02-553
84	Pipe Plug	TC-368	D02-402	D02-402
85	Valve Chest Plug	- - - -	22SR-165	22SR-165
86	Rotary Valve			
	For equal power in either direction of rotation	CCM-526	EEG-526	EE5M-526A
	For maximum power counterclockwise when			
	facing the Motor Shaft	D02-526	D10-526	D10-526-5
	For maximum power clockwise when facing the			
	Motor Shaft	CCM-503	D20-526	EEUD-526A
87	Large Valve Drive Pin	D02-527	D10-527	D10-527
*	Small Valve Drive Pin (2)	- - - -	- - - -	D02-527
88	Reverse Valve	DU-944	EU-944	EU-944
89	Throttle Valve Ball	D10-280	D10-280	D10-280
90	Poppet Throttle Valve	D02-940	D02-940	D02-940
91	Throttle Valve Spring	B01-11	B01-11	B01-11
92	Throttle Valve Cap Gasket	G601-411	G601-411	G601-411
93	Throttle Valve Cap	D02-943	D02-943	D02-943
94	Valve Chest Cover Gasket	D02-928	D10-928	- - - -
95	Valve Chest Cover	D02-546A	D10-546A	D10-546A
96	Valve Chest Long Screw (2)	D02-548	D10-548	D10-548
97	Valve Chest Short Screw (3)	D02-506	D02-506	D02-506
98	3/8" Lock Washer (5)	D02-321	D02-321	D02-321
99	3/4" Street Ell	DU-581	DU-581	- - - -
100	Throttle Control Arm	D02-555	D10-555	D10-555
101	Throttle Spring Stop Pin	D02-553	D02-553	D02-553
* 102	Throttle Lever	EU-556	EU-556	EU-556
101	Throttle Spring Stop Pin	D02-553	- - - -	- - - -
● 103	Throttle Lever Spring	D02-412B	D02-412B	D02-412B
104	Throttle Lever Guide	DU-596	DU-596	DU-596
105	Throttle Lever Bolt (2)	D02-411A	D02-411A	D02-411A
106	Throttle Lever Bolt Nut (2)	D02-418A	D02-418A	D02-418A
*	Pull Chain Throttle Lever (2)	D02-556	D02-556	D02-556
*	Throttle Lever Chain (2)	DU-413	DU-413	DU-413
*	S-Hook (2 for each Chain)	D02-421	D02-421	D02-421
*	Pull Chain Throttle Handle (2)	MR-415	MR-415	MR-415

- * Not illustrated.
- Unless otherwise specified, the Valve Chest Assembly for these Reversible Motors will include a Rotary Valve that provides equal power in either direction of rotation. See Rotary Valve (86).
- * For Sizes CCUM, DDUM and DD6UM Motors: The Throttle Lever with integral control arm that at one time was used on these Motors is no longer available. For replacement of this combination type Lever, order listed parts 100, 102, 105 (2) and 106 (2).

ALL OTHER PARTS ARE THE SAME AS CORRESPONDING PARTS FOR STATIONARY MOTORS ILLUSTRATED ON PAGE 6 AND SHOULD BE ORDERED ACCORDINGLY.

REPAIR PART LIST FOR UTILITY TYPE VALVE CHEST SIZES HHUM, HH5UM, KKUM and KK5UM

Valve Chest parts used only on the above sizes of Stationary Motors are illustrated in the accompanying view and listed below.

All other parts are the same as corresponding parts for Stationary Motors illustrated on page 12 and should be ordered accordingly.

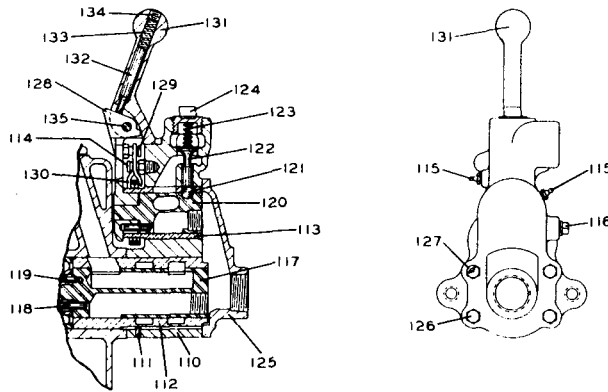

ILLUS. NUMBER (Do not use for ordering)	PART NAME FOR ORDERING (Parts indented after an item are included with that item)	PART NUMBER FOR ORDERING			
		Size HHUM	Size HH5UM	Size KKUM	Size KK5UM
○	Valve Chest Assembly	HHUM-A545	HH5UM-A545	KKUM-A545	KK5UM-A545
110	Valve Chest	HU-545A	H5U-545	KU-545A	KK5UM-545
111	Bushing Key (2)	HU-538	HU-538	HU-538	HU-538
112	Rotary Valve Bushing	HU-525S	HH5D-525S	KU-525S	K5M-525S
113	Reverse Valve Bushing	HU-945S	H5U-945S	KU-945S	KU-945S
114	Throttle Spring Stop Pin	D02-553	D02-553	D02-553	D02-553
115	Grease Fitting (2)	23-188	23-188	23-188	23-188
116	1/4" Pipe Plug (1 for Size HHUM; 2 for all others).	D02-402	D02-402	D02-402	D02-402
117	Rotary Valve				
	For equal power in either direction of rotation	HHM-526A	HH5M-526	KKM-526A	KKM-526A
	For maximum power counterclockwise when facing the Motor Shaft	HU-526A	H5U-526	KU-526A	KU-526A
	For maximum power clockwise when facing the Motor Shaft	HU-526RA	H5U-526R	KU-526RA	KU-526RA
118	Large Valve Drive Pin	HU-527	HU-527	KU-527	KU-527
119	Small Valve Drive Pin (2)	HU-627	HU-627	HU-527	HU-527
120	Reverse Valve	HU-944	H5U-944	KU-944	KU-944
121	Throttle Valve Ball	D10-280	D10-280	D10-280	D10-280
122	Poppet Throttle Valve	HU-940	HU-940	KU-940	KU-940
123	Throttle Valve Spring	HU-942	HU-942	KU-942	KU-942
124	Throttle Valve Cap	HU-943	KU-943	KU-943	KU-943
125	Valve Chest Cover	HU-546A	H5U-546	KU-546A	KU-546A
126	Valve Chest Screw (4)	HU-548	HU-548	KU-548	KU-548
127	Lock Washer (4)	D02-321	D02-321	D10-322	D10-322
128	Throttle Control Arm	HU-555A	HU-555A	KU-555A	KU-555A
129	Throttle Spring Stop Pin	D02-553	D02-553	D02-553	D02-553
● 130	Throttle Lever Spring	HU-412	HU-412	KU-412	KU-412
131	Throttle Lever	HU-556	HU-556	HU-556	HU-556
132	Throttle Lever Latch	HU-869	HU-869	HU-869	HU-869
● 133	Latch Spring	HU-567	HU-567	HU-567	HU-567
134	Throttle Lever Set Screw	HU-842	HU-842	HU-842	HU-842
135	Throttle Lever Pin	HU-870	HU-870	HU-870	HU-870
*	Throttle Lever Pin Cotter (2)	D02-524	D02-524	D02-524	D02-524

* Not illustrated.

○ Unless otherwise specified, the Valve Chest Assembly for these Reversible Motors will include a Rotary Valve that provides equal power in either direction of rotation. See Rotary Valve (117).

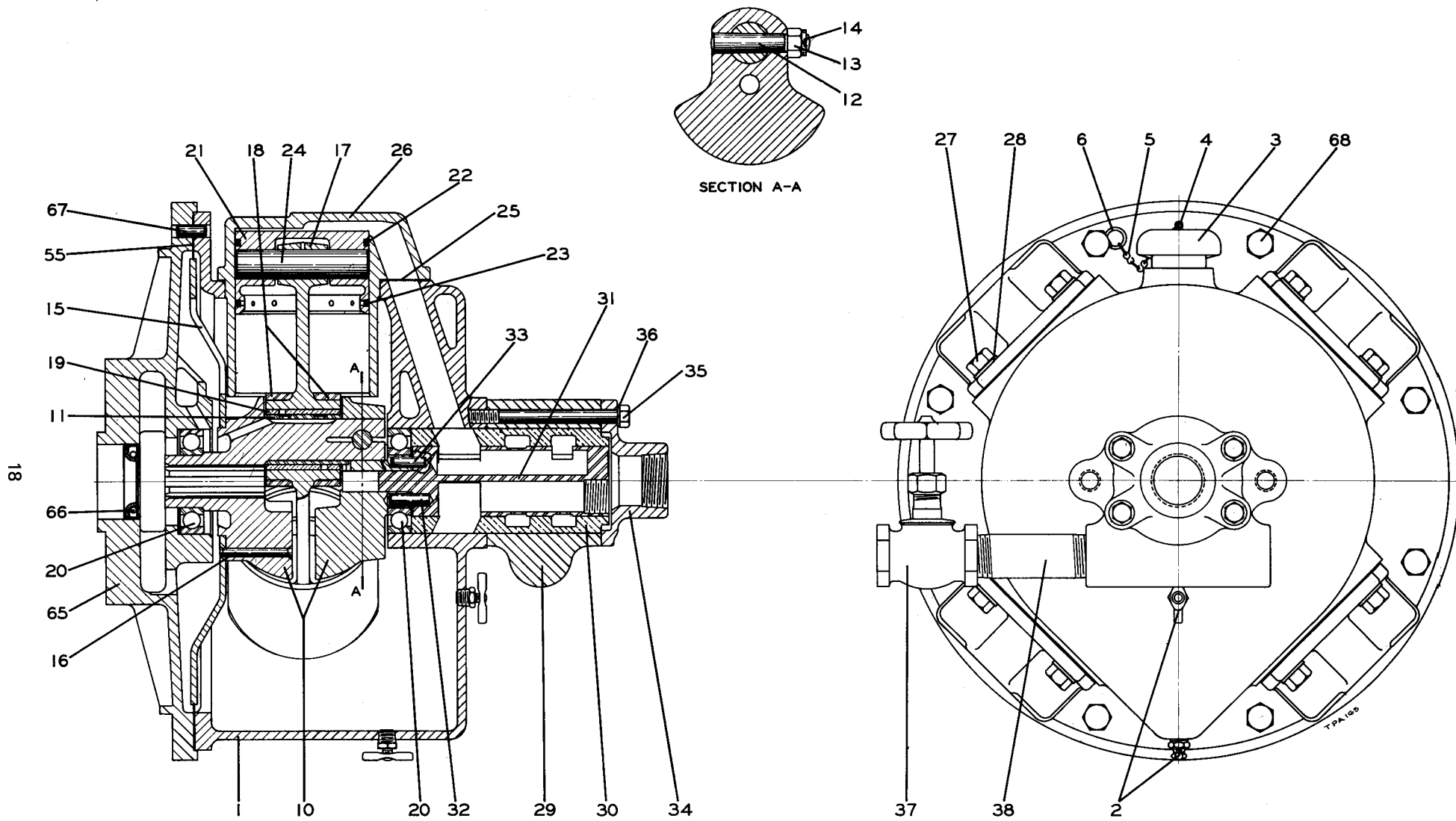

Series 56 Flange-Mounted Motor

REPAIR PART LIST FOR SERIES 56 FLANGE-MOUNTED MOTORS

Parts used only on Series 56 Flange-Mounted Motors are illustrated in the accompanying view on page 18 and listed below.

All other parts are the same as corresponding parts for Stationary Motors illustrated on pages 6 and 12 and should be ordered accordingly.

ILLUS. NUMBER (Do not use for ordering)	PART NAME FOR ORDERING (Parts indented after an item are included with that item)	PART NUMBER FOR ORDERING					
		Sizes CM56, CCM56, CCUM56, DM56, DDM56, DDUM56, D6M56, DD6M56, DD6UM56	Sizes EM56, EEM56, EEUM56, E5M56, EE5M56, EE5UM56	Sizes HM56, HHM56, HHUM56	Sizes H5M56, HH5M56, HH5UM56	Sizes KM56, KKM56, KKUM56	Sizes K5M56, KK5M56, KK5UM56
65	Motor Mounting Cover	C04-276	C10-276	HM-276	H5M-276	KM-276	K5M-276
66	Oil Seal	C04-271	C10-271	HM-271	HM-271	KM-271	KM-271
67	Motor Cover Dowel	C04-274	C04-274	D02-347	D02-347	D02-347	D02-347
68	Motor Case Screw	D02-312	D10-312	215-37	215-37	KX-36	KX-36
*	Motor Case Screw Nut } (10 for five-cylinder motor; 8 for all others)	D02-418	D01-418	215-182	215-182	HU-776	HU-776
*	Blank Motor Shaft (Blank or Finished to customer's specifications)	C04-277	C10-277	HM-277	HM-277	KM-277	KM-277

* Not illustrated.

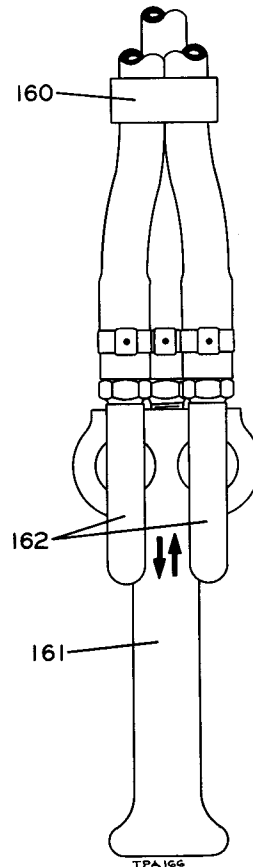
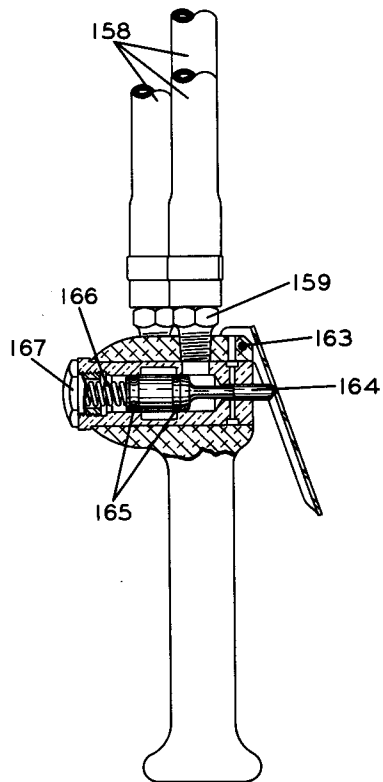
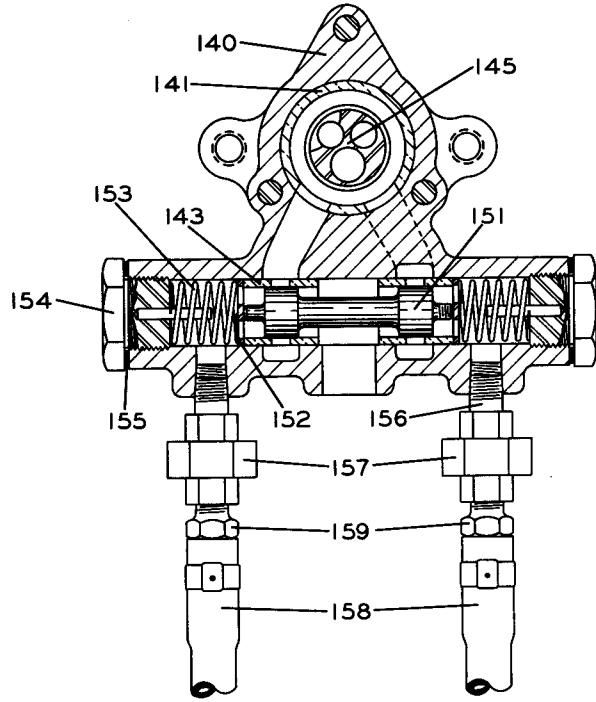
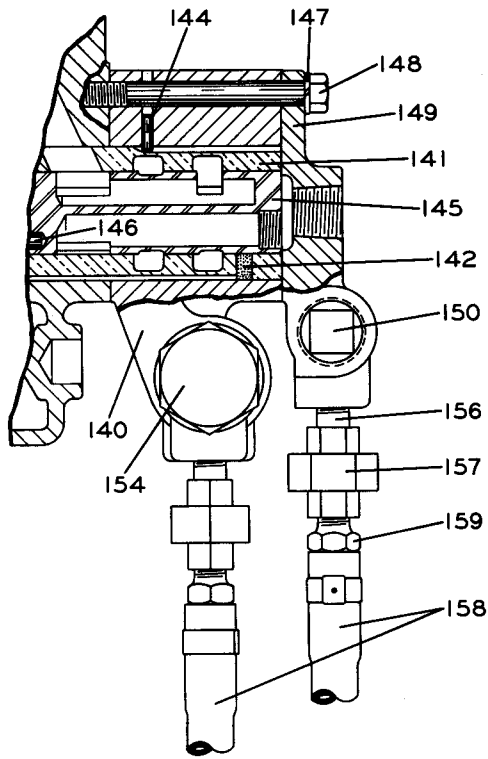

Pendent Throttle for Sizes CCM, DDM and DD6M

REPAIR PART LIST FOR PENDENT THROTTLE ON SIZES CCM, DDM and DD6M MOTORS

Refer to illustration on page 20.

ILLUSTRATION NUMBER (Do not use for ordering)	PART NAME FOR ORDERING (Parts indented after an item are included with that item)	PART NUMBER FOR ORDERING
○	Shuttle Valve Chest Assembly	CCM-A245
140	Shuttle Valve Chest	CCM-245
141	Rotary Valve Bushing	D02-525A
142	Valve Oiler	JA4-75
143	Shuttle Valve Bushing (2)	D02-247
144	Shuttle Valve Chest Bushing Key	R0AJ-191
145	Rotary Valve For equal power in either direction of rotation (standard) For maximum power counterclockwise when facing the Motor Shaft. For maximum power clockwise when facing the Motor Shaft	CCM-526 D02-526 CCM-503
146	Valve Drive Pin	D02-527
147	3/8" Lock Washer (3)	D02-321
148	Valve Chest Screw (3)	D02-548
149	Shuttle Valve Chest Cover	D02-241
150	Valve Chest Cover Plug	22SR-165
151	Shuttle Valve	CCM-246
152	Shuttle Valve Washer (2)	D02-248
153	Shuttle Valve Spring (2)	D02-250
154	Shuttle Valve Cap (2)	D02-238
155	Shuttle Valve Cap Gasket (2)	D02-239
156	Pendent Throttle Inlet Nipple (3)	D02-908
157	Control Hose Union (3)	D02-129
158	Control Hose (3) 7 ft. long length as specified	CCM-930 D02-L930 D02-14
159	Hose Nipple (2 for each Hose)	D10-927
160	Hose Binder (3)	D02-269
161	Pendent Throttle Handle	R00H-273A
162	Pendent Throttle Lever (2)	DLC-120
163	Throttle Lever Pin	D02-264
164	Pendent Throttle Valve (2)	R0AR-210
● 165	Pendent Throttle Valve Seal Ring (4)	D01-51
● 166	Pendent Throttle Valve Spring (2)	D02-180
167	Pendent Throttle Valve Cap (2)	MR-939
*	Control Hose Exhaust Valve (2) (Required when Control Hose length exceeds 17 ft.)	

- * Not illustrated.
- Unless otherwise specified, the Shuttle Valve Chest Assembly for these Reversible Motors will include a Rotary Valve that provides equal power in either direction of rotation. See Rotary Valve (145).

AIR STRAINER ASSEMBLY FOR SIZES CM, CCM, DM, DDM, D6M, DD6M and EM MOTORS

ILLUS. NUMBER (Do not use for ordering)	PART NAME FOR ORDERING (Parts indented after an item are included with that item)	PART NUMBER FOR ORDERING
661	Air Strainer Assembly	EU-A267
662	Air Strainer Screen	P25-61A
663	Air Strainer Cap	P25-268
664	Air Strainer Plug	P25-536
*	Air Strainer Nipple	D02-456

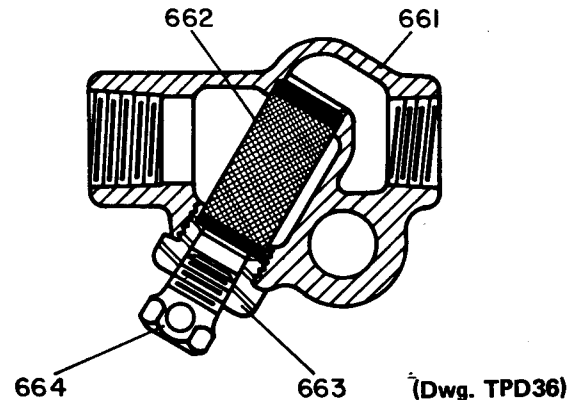

- * Not illustrated.

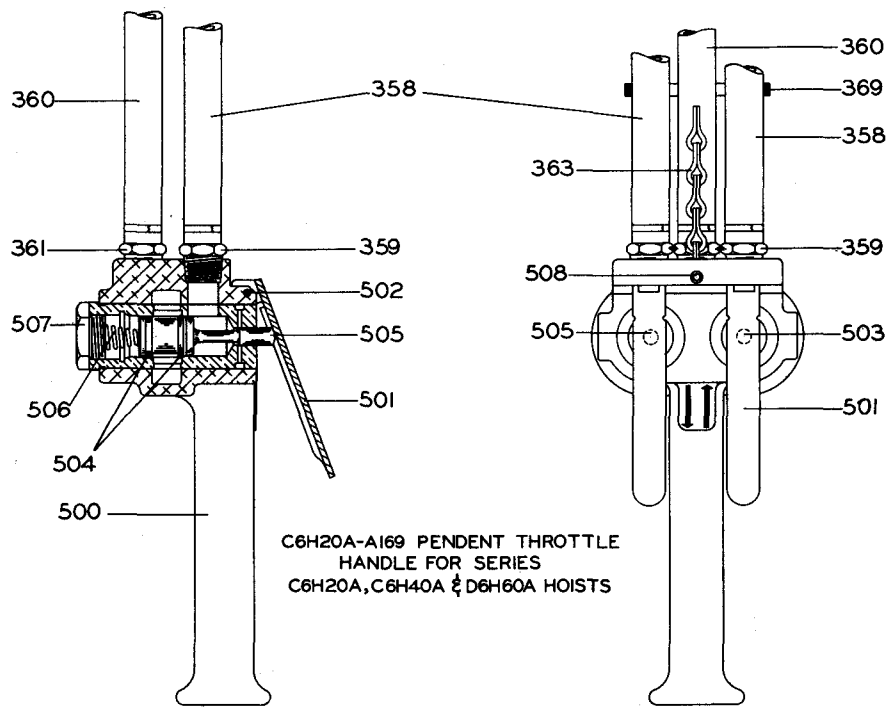

**EEM-A169 Pendent Throttle Handle
(Tapped 1/2" Pipe Thread)**

**REPAIR PART LIST FOR
PENDENT THROTTLE ON SIZES EEM AND EE5M MOTORS**

ILLUS. NUMBER (Do not use for ordering)	PART NAME FOR ORDERING (Parts indented after an item are included with that item)	PART NUMBER FOR ORDERING	
		Size EEM	Size EE5M
	VALVE CHEST PARTS (Refer to top illustration, page 20)		
○	Shuttle Valve Chest Assembly	EEM-A245	EE5M-A245
140	Shuttle Valve Chest	EEM-245	EE5M-245
141	Rotary Valve Bushing	D10-525A	E5UD-525A
142	Valve Oiler	JA4-75	- - - -
143	Shuttle Valve Bushing (2).	D10-247	D10-247
144	Shuttle Valve Chest Bushing Key	R0AJ-191	B12-255
145	Rotary Valve		
	For equal power either direction of rotation (standard)	EEG-526	EE5M-526A
	For maximum power counterclockwise when facing the Motor Shaft	D10-526	D10-526-5
	For maximum power clockwise when facing the Motor Shaft	D20-526	EEUD-526A
*	Large Valve Drive Pin	D10-527	D10-527
146	Small Valve Drive Pin	- - - -	D02-527
147	3/8" Lock Washer (6)	D02-321	D02-321
148	Valve Chest Screw (Long).	D10-548	D10-548
*	Valve Chest Screw (Short) (5)	D02-506	D02-506
*	Shuttle Valve Chest Cover Gasket	D10-236	D10-236
149	Shuttle Valve Chest Cover	D10-241	EE5M-241
150	Valve Chest Cover Plug	22SR-165	22SR-165
151	Shuttle Valve	EEM-246	EEM-246
152	Shuttle Valve Washer (2)	D10-248	D10-248
153	Shuttle Valve Spring (2).	D10-250	D10-250
154	Shuttle Valve Cap (2)	D10-238	D10-238
155	Shuttle Valve Cap Gasket (2)	D10-239	D10-239

* Not illustrated.

Unless otherwise specified, the Shuttle Valve Chest Assembly for these Reversible Motors will include a Rotary Valve that provides equal power in either direction. See Rotary Valve (145).

PENDENT THROTTLE HANDLE, HOSE AND FITTINGS

ILLUSTRATION NUMBER (Do not use for ordering)	PART NAME FOR ORDERING (Parts indented after an item are included with that item)	PART NUMBER FOR ORDERING
156	Pendent Throttle Inlet Nipple (3) (illustrated on page 20)	AAM-286
157	Hose Union (3) (illustrated on page 20)	AAM-282
358	Control Hose Assembly (2) 5 ft. length	C6H20A-A930
	Length as specified	C6H20A-AL930
359	Hose Nipple (2 for each Hose)	C6H20A-14
360	Live Air Hose Assembly 5 ft. length	C6H20A-A930
	Length as specified	C6H20A-AL930
361	Hose Nipple (2)	C6H20A-14
369	Hose Binder (3)	D10-927
† 500	Pendent Throttle Handle Assembly (tapped 1/2" Pipe Thread)	EEM-A169
501	Pendent Throttle Lever (2)	C6H20A-273
502	Throttle Lever Pin	C6H20A-281
503	Pendent Throttle Valve Assembly (2)	C6H20A-A164
● 504	Pendent Throttle Valve Seal Ring (2 for each Valve)	AF160-289
● 506	Pendent Throttle Valve Spring (2)	T01-308
507	Pendent Throttle Valve Cap (2)	C6H20A-180
508	Chain Anchor Pin Lock Screw	H54U-561
*	Throttle Chain Anchor Pin	R4-15
*	Control Hose Exhaust Valve (2) (required when Control Hose length exceeds 15 ft.)	C6H20A-939
*	Reducing Bushing (3/4" male pipe to 1/2" female pipe)	D02-420

* Not illustrated.

† Refer to Superseded Pendent Throttle Handle on pages 23 and 24.

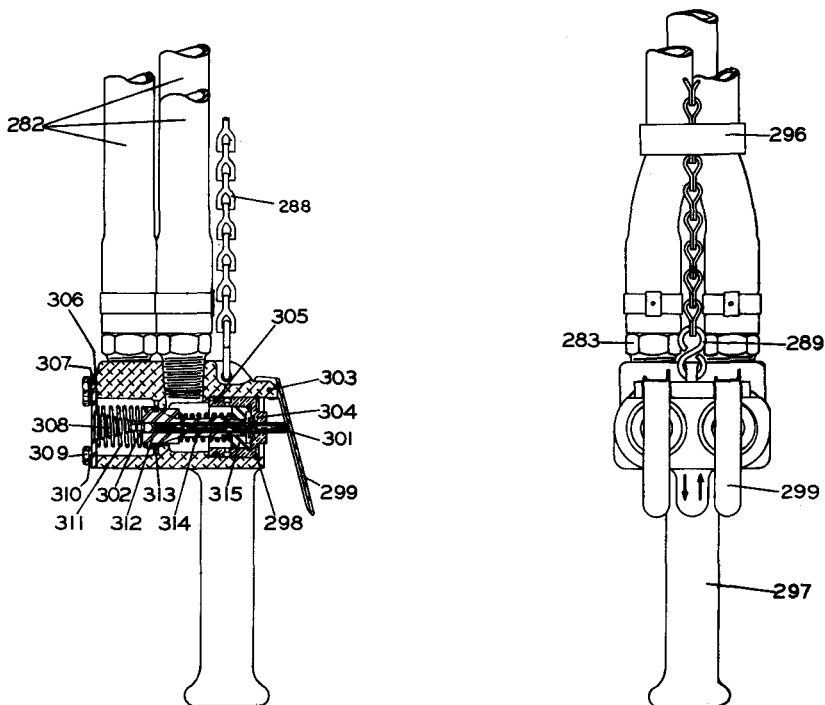

Superseded Pendent Throttle Handle

For Sizes EEM and EE5M
(Tapped 3/4" Pipe Thread)
(Parts listed on page 24)

**SUPERSEDED PENDENT THROTTLE HANDLE, HOSE AND FITTINGS
FOR SIZES EEM AND EE5M MOTORS
(Illustrated on page 23)**

ILLUSTRATION NUMBER (Do not use for ordering)	PART NAME FOR ORDERING (Parts indented after an item are included with that item)	PART NUMBER FOR ORDERING
156	Pendent Throttle Inlet Nipple (3) (illustrated on page 20)	J3-840
157	Hose Union (3) (illustrated on page 20)	C04-282
282	Control Hose (3) 5 ft. length Length as specified	D10-930 D10-L930
283	Hose Nipple (2 for each Hose)	J3-581
296	Hose Binder (3)	D10-927
297	Pendent Throttle Handle (tapped 3/4" Pipe Thread)	★
298	Handle Bushing Retainer (2)	D10-227
299	Pendent Throttle Lever (2)	R00H-273A
301	Throttle Valve Stem (2)	D10-214A
302	Throttle Valve Stem Seal (2)	R000BRIC-283
303	Throttle Lever Pin	DLC-1281
304	Pendent Throttle Handle Bushing (2)	D10-225
305	Handle Bushing Seal (2)	D10-226
306	Pendent Throttle Handle Cover Gasket	D10-219
307	Pendent Throttle Handle Cover	D10-218
308	Throttle Valve Stem Spring (2)	R2F-262
309	Pendent Throttle Handle Cover Cap Screw (7)	R3-7
310	Cover Cap Screw Lock Washer (7)	L01-67
311	Pendent Throttle Valve Spring (2)	D10-213
312	Pendent Throttle Valve (2)	D10-211
313	Pendent Throttle Valve Face (one for each Valve)	EU-948
314	Bleed Valve Spring (2)	D10-275
315	Bleed Valve (2)	D10-223
*	Control Hose Exhaust Valve (2) (Required when Control Hose length exceeds 15 ft.)	D10-939

* Not illustrated.

★ This Handle is discontinued. However, component parts are still available as repair parts.