

**force**  <sup>TM</sup> **HYDRAULIC  
WINCHES**  
**PARTS, OPERATION AND MAINTENANCE  
SUPPLEMENT\***

## MODEL FH5

\* This supplement should be used in conjunction with supporting documentation for the hydraulic motor, disc brake, reduction gear assembly and controls as applicable.

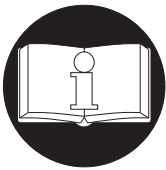

**READ THIS MANUAL BEFORE USING THESE PRODUCTS.** This manual contains important safety, installation, and maintenance information. Make this manual available to all persons responsible for the operation, installation and maintenance of these products.

### **⚠ WARNING**

Do not use this winch for lifting, supporting, or transporting people or lifting or supporting loads over people.

Always operate, inspect and maintain this winch in accordance with American National Standards Institute Safety Code (ASME B30.7) and any other applicable safety codes and regulations.

Refer all communications to the nearest Ingersoll-Rand Material Handling Office or Distributor.

# TABLE OF CONTENTS

| Description  | Page No. |
|--|----------|
| <b>Safety Information</b>                                  |          |
| Danger, Caution, Warning and Notice . . . . .              | 3        |
| Safe Operating Instructions . . . . .                      | 4        |
| Warning Labels . . . . .                                   | 4        |
| <b>Specifications</b>                                      |          |
| Model Code . . . . .                                       | 5        |
| General Specifications . . . . .                           | 6        |
| <b>Installation</b>  |          |
| Mounting . . . . .   | 7        |
| Wire Rope . . . . .  | 8        |
| Hydraulic System . . . . .                                 | 9        |
| Initial Operating Checks . . . . .                         | 10       |
| <b>Operation</b>   |          |
| Hydraulic System . . . . .                                 | 11       |
| Winch Controls . . . . .                                   | 11       |
| Winch Brakes . . . . .                                     | 11       |
| Drum Locking Pin . . . . .                                 | 12       |
| <b>Lubrication</b>   |          |
| Recommended Lubricants . . . . .                           | 13       |
| Component Lubrication . . . . .                            | 13       |
| Reduction Gear Assembly . . . . .                          | 13       |
| Automatic Disc Brake . . . . .                             | 14       |
| Seals and Bearings . . . . .                               | 14       |
| Drum Locking Pin . . . . .                                 | 14       |
| Wire Rope . . . . .  | 14       |
| <b>Inspection</b>  |          |
| Records and Reports . . . . .                              | 15       |
| Frequent Inspection . . . . .                              | 15       |
| Periodic Inspection . . . . .                              | 15       |
| Winches Not in Regular Use . . . . .                       | 16       |
| Inspection and Maintenance Report . . . . .                | 17       |
| <b>Troubleshooting</b>                                     |          |
| Troubleshooting Chart . . . . .                            | 18–19    |
| <b>Maintenance</b>   |          |
| Maintenance Intervals . . . . .                            | 20       |
| Adjustments . . . . .                                      | 20       |
| Hydraulic System General Maintenance . . . . .             | 20       |
| Disassembly Instructions . . . . .                         | 21       |
| Cleaning, Inspection and Repair . . . . .                  | 22       |
| Assembly Instructions . . . . .                            | 23       |
| Testing . . . . .  | 24       |
| <b>Parts Information</b>                                   |          |
| Winch Drawings and Parts Lists Table of Contents . . . . . | 25       |
| Parts Drawings and Parts Lists . . . . .                   | 26-32    |
| Parts Ordering Information . . . . .                       | 33       |
| Return Goods Policy . . . . .                              | 33       |
| Warranty . . . . .   | 35       |
| Office Locations . . . . .                                 | 36       |

## SAFETY INFORMATION

This manual provides important information for all personnel involved with the safe installation, operation and proper maintenance of this product. Even if you feel you are familiar with this or similar equipment, you should read this manual before operating the product.

### Danger, Warning, Caution and Notice

Throughout this manual there are steps and procedures which, if not followed, may result in a hazard. The following signal words are used to identify the level of potential hazard.

#### DANGER

Danger is used to indicate the presence of a hazard which *will* cause *severe* injury, death, or substantial property damage if the warning is ignored.

#### WARNING

Warning is used to indicate the presence of a hazard which *can* cause *severe* injury, death, or substantial property damage if the warning is ignored.

#### CAUTION

Caution is used to indicate the presence of a hazard which *will* or *can* cause injury or property damage if the warning is ignored.

#### NOTICE

Notice is used to notify people of installation, operation, or maintenance information which is important but not hazard-related.

### Safety Summary

#### WARNING

- **Do not use this unit or attached equipment for lifting, supporting, or transporting people or lifting or supporting loads over people.**
- **The supporting structures and load-attaching devices used in conjunction with these units must provide a safety factor of at least three times the rated capacity of the unit. This is the customer's responsibility. If in doubt, consult a registered structural engineer.**

#### NOTICE

- **Lifting and handling equipment is subject to different regulations in each country. These regulations may not be specified in this manual.**

**Ingersoll-Rand** Material Handling winches are manufactured in accordance with the latest ASME B30.7 standards.

The National Safety Council, Accident Prevention Manual for Industrial Operations, Eighth Edition and other recognized safety sources make a common point: Employees who work near suspended loads or assist in hooking on or arranging a load should be instructed to keep out from under the load. From a safety standpoint, one factor is paramount: conduct all lifting or pulling operations in such a manner that if there were an equipment failure, no personnel would be injured. This means keep out from under a raised load and keep out of the line of force of any load.

The Occupational Safety and Health Act of 1970 generally places the burden of compliance with the owner/employer, not the manufacturer. Many OSHA requirements are not concerned or connected with the manufactured product but are, rather, associated with the final installation. It is the owner's and user's responsibility to determine the suitability of a product for any particular use. It is recommended that all applicable industry, trade association, federal, state and local regulations be checked. Read all operating instructions and warnings before operation.

**Rigging:** It is the responsibility of the operator to exercise caution, use common sense and be familiar with proper rigging techniques. Refer to ASME B30.9 for rigging information, American National Standards Institute, 1430 Broadway, New York, NY 10018.

This manual has been produced by **Ingersoll-Rand** to provide dealers, mechanics, operators and company personnel with the information required to install, operate, maintain and repair the products described herein.

It is extremely important that mechanics and operators be familiar with the servicing procedures of these products, or like or similar products, and are physically capable of conducting the procedures. These personnel shall have a general working knowledge that includes:

1. Proper and safe use and application of mechanics common hand tools as well as special **Ingersoll-Rand** or recommended tools.
2. Safety procedures, precautions and work habits established by accepted industry standards.

**Ingersoll-Rand** cannot know of, or provide all the procedures by which product operations or repairs may be conducted and the hazards and/or results of each method. If operation or maintenance procedures not specifically recommended by the manufacturer are conducted, it must be ensured that product safety is not endangered by the actions taken. If unsure of an operation or maintenance procedure or step, personnel should place the product in a safe condition and contact supervisors and/or the factory for technical assistance.

## SAFE OPERATING INSTRUCTIONS

The following warnings and operating instructions have been adapted in part from American National (Safety) Standard ASME B30.7 and are intended to avoid unsafe operating practices which might lead to injury or property damage.

**Ingersoll-Rand** recognizes that most companies who use winches have a safety program in force at their facility. In the event that some conflict exists between a rule set forth in this publication and a similar rule already set by an individual company, the more stringent of the two should take precedence.

Safe Operating Instructions are provided to make an operator aware of dangerous practices to avoid and are not necessarily limited to the following list. Refer to specific sections in the manual for additional safety information.

1. Only allow personnel trained in safety and operation of this winch to operate and maintain this product.
2. Only operate a winch if you are physically fit to do so.
3. When a **“DO NOT OPERATE”** sign is placed on the winch, or controls, do not operate the winch until the sign has been removed by designated personnel.
4. Before each shift, check the winch for wear and damage. Never use a winch that inspection indicates is worn or damaged.
5. Never lift a load greater than the rated capacity of the winch. Refer to **“SPECIFICATIONS”** section.
6. Keep hands, clothing, etc., clear of moving parts.
7. Never place your hand in the throat area of a hook or near wire rope spooling onto or off the winch drum.
8. Always rig loads properly and carefully.
9. Be certain the load is properly seated in the saddle of the hook. Do not tiplod the hook as this leads to spreading and eventual failure of the hook.
10. Do not **“side pull”** or **“yard”**.
11. Make sure everyone is clear of the load path. Do not lift a load over people.
12. Never use the winch for lifting or lowering people, and never allow anyone to stand on a suspended load.
13. Ease the slack out of the wire rope when starting a lift or pull. Do not jerk the load.
14. Do not swing a suspended load.
15. Never suspend a load for an extended period of time.
16. Do not leave a load suspended when the winch is unattended or not in use.
17. Pay attention to the load at all times when operating the winch.
18. After use, or when in a non-operational mode, the winch should be secured against unauthorized and unwarranted use.
19. The operator must maintain an unobstructed view of the load at all times.
20. Never use the winch wire rope as a sling.

## WARNING LABELS

Each unit is shipped from the factory with the warning labels shown. If the labels are not attached to your unit, order new labels and install them. Refer to the parts list for the part number. Labels are not shown actual size.



A vertical rectangular warning label with a black background and white text. At the top left is a white triangle with a black exclamation mark. To its right, the word "WARNING" is written in large, bold, white capital letters. Below this, the text "Failure to follow these warnings may result in death, severe injury or property damage:" is written in white. This is followed by a list of six bullet points, each starting with a white circle containing a black exclamation mark. To the right of the first bullet point is a white circular icon showing an open book with a lit candle on top. At the bottom of the label, there is a small white box containing the text "Read the latest edition of ASME B30.7. Comply with other federal, state and local rules. P/N 71060529/C for winches." To the right of this box is the logo for "INGERSOLL-RAND MATERIAL HANDLING" in white capital letters.

# SPECIFICATIONS

## Model Code Explanation

Example: FH5-24MK1P

FH5 - 24 M K 1 P

### Series (Capacity)

**FH5** = Hydraulic Powered Winch (5 metric ton / 11,000 lbs.)

### Drum Flange Height or ManRider®:

- = Standard flange: 27 inch (660 mm) diameter
- T = Tall flange: 35 inch (890 mm) diameter
- MR = ManRider® (Refer to ManRider® Supplement Form #MHD56042)
- TGL = Guideline
- TPL = Podline

### Drum Length (Distance between drum flanges):

- 12 = 12 inch (306 mm)
- 16 = 16 inch (406 mm)
- 24 = 24 inch (610 mm) Standard**
- 30 = 30 inch (760 mm)
- 36 = 36 inch (915 mm) Tall Flange Winch only

### Drum Brake:

- A = Automatic Drum Brake
- M = Manual Drum Brake**
- X = None

### Disc Brake:

- K = Automatic Disc Brake**
- X = None

### Control:

- 1 = Winch mounted lever throttle (Standard)**
- \* 2 = Customer provided

### Options:

- \* 7 = Drum Grooving (Number = wire rope size in sixteenths, e.g. 7/16 inch)
- \*\* C = Low Temperature Components; specify -10° C (14° F) or -20° C (-4° F)
- \* D = Drum Divider Flange and additional wire rope anchor
- G = Drum Guard
- L = Drum Locking Pin
- \*\* M1 = Material Traceability (Typical material results)
- \*\* M2 = Material Traceability (Actual material results)
- \*\* M3 = Material Traceability (Actual material results for these parts in finished, as-delivered condition)
- N = Type Approval – Specify:  
A = American Bureau of Shipping (ABS); N = Det Norske Veritas (DNV); R = Lloyd’s Register of Shipping (LRS)
- P = Marine 812 top coat**
- Q = Special paint; please specify
- \* S = Rotary Limit Switch
- \* U = Underwound
- \*\* W = Witness; please specify
- X = Testing; please specify
- Z = Sand Blast and Carbozinc Primer only
- \* -E = Compliance with European Machinery Directive (includes Emergency Stop and Overload Protection)

### Notes:

- \* Not covered in this manual. Contact the factory or your nearest **Ingersoll-Rand** distributor for information.
- \*\* Documentation, witness testing and material traceability available; must be requested at time of order. Specify options or contact the factory or your nearest **Ingersoll-Rand** distributor for information.

| General Specifications:                                  |   | Model  |                |  |                |
|--|---|--|----------------|--|----------------|
|  |   | FH5  |                | FH5T   |                |
| Utility Rating 5:1 design factor                         | Full Drum Line Pull @ 2700 psi (18620 kPa/ 186 bar) | 11,000 lbs   | 4,490 kgs      | 8,400 lbs  | 3810 kgs       |
|  | Mid Drum Line Speed @ 40 gpm (151 l/min)            | 65 fpm   | 20 m/min       | 80 fpm   | 24 m/min       |
|  | FH5-24MX1 Net Weight                                | 1780 lbs   | 807 kg         | ---  | ---            |
|  | FH5T-24MX1 Net Weight                               | ---  | ---            | Contact Factory  |                |
| <b>Drum Barrel Diameter</b>                              |   | 15 inches  | 381 mm         | 15 inches  | 381 mm         |
| <b>Drum Flange Diameter</b>                              |   | 27.25 inches   | 692 mm         | 35.25 inches   | 895 mm         |
| <b>Motor Displacement</b>                                |   | 6.72 cu. in/rev  | 110 cu. cm/rev | 6.72 cu. in/rev  | 110 cu. cm/rev |
| <b>Maximum System Inlet pressure **</b>                  |   | 3000 psi   | 207 bar        | 3000 psi   | 207 bar        |
| <b>Maximum System Flow at rated load **</b>              |   | 104 gpm  | 393 l/min      | 104 gpm  | 393 l/min      |
| <b>Hose size</b>   |   | Refer to "INSTALLATION" section for recommended hose sizes |                |  |                |
| <b>* Drum Wire Rope Storage Capacity (feet / metres)</b> | <b>Drum Length (inches)</b>                         | <b>Wire Rope Diameter</b>                                  |                |  |                |
|  |   | <b>0.625 inch</b>  | <b>16 mm</b>   | 0.625 inch (16 mm) diameter wire rope not recommended for use on FH5T winches. |                |
|  | 12  | 937 ft   | 247 m          |  |                |
|  | 16  | 1106 ft  | 335 m          |  |                |
|  | 24 (Standard)                                       | 1681 ft  | 509 m          |  |                |
|  | 30  | 2112 ft  | 640 m          |  |                |
|  |   | <b>0.75 inch</b>   | <b>18 mm</b>   | <b>0.75 inch</b>   | <b>18 mm</b>   |
|  | 12  | 515 ft   | 164 m          | 1174 ft  | 371 m          |
|  | 16  | 698 ft   | 222 m          | 1592 ft  | 503 m          |
|  | 24 (Standard)                                       | 1064 ft  | 338 m          | 2426 ft  | 766 m          |
|  | 30  | 1338 ft  | 425 m          | 3053 ft  | 963 m          |
|  | 36 (Tall flange only)                               | ---  | ---            | 3679 ft  | 1160 m         |
|  |   | <b>0.875 inch</b>  | <b>20 mm</b>   | <b>0.875 inch</b>  | <b>20 mm</b>   |
|  | 12  | 374 ft   | 151 m          | 838 ft   | 310 m          |
|  | 16  | 509 ft   | 205 m          | 1139 ft  | 420 m          |
|  | 24 (Standard)                                       | 778 ft   | 312 m          | 1742 ft  | 641 m          |
|  | 30  | 979 ft   | 393 m          | 2194 ft  | 807 m          |
|  | 36 (Tall flange only)                               | ---  | ---            | 2646 ft  | 973 m          |

\*Wire rope storage capacity based on wire rope top layer located a minimum of 1/2 inch (13 mm) below drum flange as meets ASME B30.7. The wire rope storage capacities listed may vary from figures stated elsewhere.

\*\* Contact factory prior to operating winch with pressures and flow rates above the 5:1 utility rating.

### Description of Operation

FH5 winches are hydraulic powered, planetary geared units designed for lifting and pulling applications. FH5 winches are supplied with either an automatic disc brake, a manual or automatic externally mounted drum band brake, or a combination of both.

The output from an externally mounted hydraulic motor is transmitted through a coupling and shaft to the planetary reduction gear assembly.

The FH5 winch disc brake assembly consists of friction plates splined to a hub which in turn is connected to the drive shaft from the motor. The brake friction plates are clamped to the drum shaft through a spring applied piston.

The winch brake typically consists of a fail-safe disc brake and a counterbalance valve. The brake is disengaged in the lowering (payout) direction only. In the raise (haul-in) direction, the brake remains engaged, and an internal sprag clutch provides fail-safe load lifting, preventing momentary downward load drifting at the instant the winch control valve (refer to manufacturer's provided information) is shifted to raise the load. The brake release oil pressure is provided by fluid pressure ported from the winch motor to the brake housing.

The counterbalance valve will prevent a runaway load condition. Should the load try to drop faster than the winch is paying out, overrunning the winch motor, the valve will sense a low pressure condition at the motor inlet, and restrict fluid flow from the motor outlet. This creates a fluid back-pressure on the winch motor, causing the motor to quickly slow down, stopping the runaway load.

The counterbalance valve should be preset to operate a minimum of 130% of the maximum oil pressure induced by the rated winch load.

The drum band brake operates by applying a friction force between the drum brake and winch drum. The manual brake requires an operator to engage and disengage the brake using a lever located on top of the brake band. The automatic drum band brake operation is similar to the disc brake with the following exception: the automatic drum band brake fully disengages in both the haul-in and payout directions.

## Traceability

Load bearing parts are documented to provide traceability. The documentation includes chemical and physical properties of the raw material, heat treating, hardening, tensile and charpy tests as required for the part. Units with M2 or M3 in the model code have traceable load-bearing components. Components with part numbers ending in CH are charpy parts for use under extreme cold conditions. Traceability requirements must be stated when reordering these parts for continued certification.

## INSTALLATION

Prior to installing the winch, carefully inspect it for possible shipping damage. Winches are supplied fully lubricated from the factory. Before operation check oil levels and adjust as necessary. Use the proper type of oil as recommended in the "LUBRICATION" section.

### ⚠ CAUTION

• Owners and users are advised to examine specific, local or other regulations, including American National Standards Institute and/or OSHA Regulations which may apply to a particular type of use of this product before installing or putting winch to use.

## Mounting

Refer to Dwg. MHP0133 on page 7 and Table 1 on page 7. Care must be taken when moving, positioning or mounting the winch. In most cases, lifting lugs have been provided to assist in handling the winch. If the lug locations are improper for your specific installation, great care should be taken to ensure that the winch, when lifted, will be properly balanced. Determine the weight of your winch by referring to the "SPECIFICATIONS" section. Lift the winch 3 to 4 inches (75 to 100 mm) off the ground. Verify winch is balanced and secure before continuing lift. Mount the winch so the axis of the drum is horizontal. If the winch is to be mounted in an inverted position it may be necessary to reposition the motor parts.

1. The winch mounting surface must be flat and of sufficient strength to handle the rated load plus the weight of the winch and attached equipment. An inadequate foundation may cause distortion or twisting of the winch uprights and side rails resulting in winch damage.
2. Make sure the mounting surface is flat to within 0.005 inch (0.127 mm) per inch of drum length. Shim if necessary.
3. Mounting bolts must be 3/4 inch (18 mm) Grade 8 or better. Use self-locking nuts or nuts with lockwashers.
4. Tighten 3/4 inch (18 mm) mounting bolts evenly and torque to 380 ft lbs (515 Nm) for dry thread fasteners. If the fasteners are plated, lubricated or a thread locking compound is used, torque to 280 ft lbs (380 Nm).

5. Maintain a fleet angle between the sheave and winch of no more than 1-1/2°. The lead sheave must be on a center line with the drum and, for every inch (25 mm) of drum length, be at least 1.6 feet (0.5 metre) from the drum. Refer to Dwg. MHP1811 on page 8 and Table 2 on page 8.
6. Do not weld to any part of the winch.

### Winch Bolt Hole Mounting Dimensions

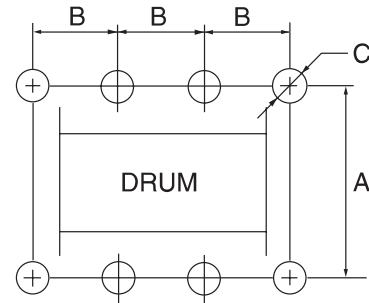

(Dwg. MHP0133)

**Table 1 Winch Bolt Hole Mounting Dimensions**

| Dimension                    |      | Drum Length (inches) |      |      |     |      |
|------------------------------|------|----------------------|------|------|-----|------|
|                              |      | 12                   | 16   | 24   | 30  | 36*  |
| 'A' FH5                      | inch | 31.25                |      |      |     | ---  |
|                              | mm   | 794                  |      |      |     | ---  |
| 'A' FH5T                     | inch | 34.25                |      |      |     | ---  |
|                              | mm   | 870                  |      |      |     | ---  |
| 'B' (with Drum Brake)        | inch | 7.5                  | 9    | 10.5 | 10  | 11.5 |
|                              | mm   | 190                  | 229  | 267  | 254 | 292  |
| 'B' (without Drum Brake)     | inch | 6                    | 6.25 | 9    | 12  | 14   |
|                              | mm   | 152                  | 159  | 229  | 305 | 356  |
| 'C'                          | inch | 13/16                |      |      |     | ---  |
|                              | mm   | 20                   |      |      |     | ---  |
| Bolt Hole Qty each Side Rail |      | 4                    |      |      | 5   |      |

\*36 inch drum length applies to FH5T (tall flange) only.

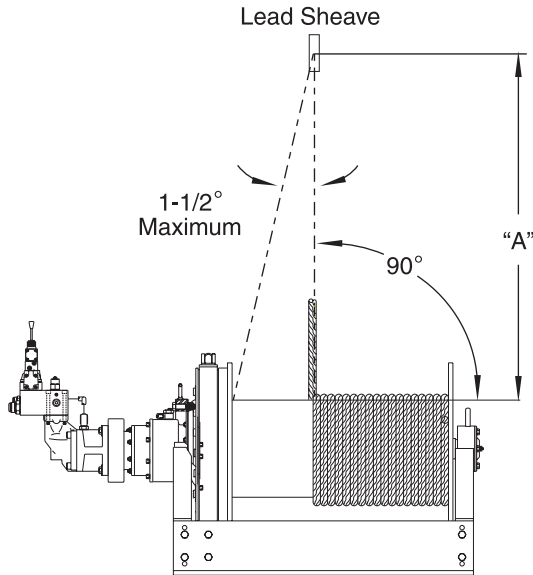

(Dwg. MHP1811)

**Table 2 Lead Sheave Minimum Distance**

| Drum Length<br>(inches) | 'A' Minimum Distance * |        |
|-------------------------|------------------------|--------|
|                         | feet                   | metres |
| 12                      | 19.2                   | 5.85   |
| 16                      | 25.6                   | 7.8    |
| 24                      | 38.4                   | 11.7   |
| 30                      | 48                     | 14.6   |
| 36                      | 57.6                   | 17.5   |

\* 'A' = 1.6 feet (0.5 metre) per inch of drum length.

Notes:

1. Maintain a minimum of 3 tight wraps of wire rope on drum at all times.
2. Ensure wire rope does not exceed top layer requirement. Refer to "SPECIFICATIONS" section for drum capacity.

### Wire Rope

## CAUTION

- Maintain at least 3 tight wraps of wire rope on the drum at all times.
- Install the wire rope to come off the drum for overwind operation. Refer to Dwg. MHP1755 on page 8.

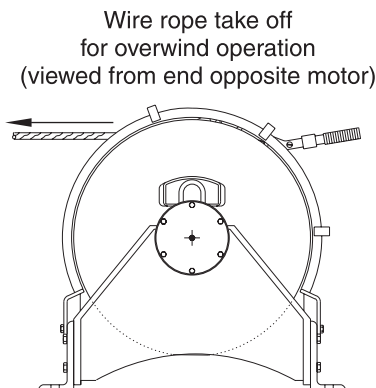

(Dwg. MHP1755)

## NOTICE

- Some applications may require underwind operation. Consult the factory prior to use.

### Wire Rope Selection

Consult a reputable wire rope manufacturer or distributor for assistance in selecting the appropriate type and size of wire rope and, where necessary, a protective coating. Use a wire rope that provides an adequate safety factor to handle the actual working load and that meets all applicable industry, trade association, federal, state and local regulations.

When considering wire rope requirements the actual working load must include not only the static or dead load but also loads resulting from acceleration, retardation and shock load.

Consideration must also be given to the size of the winch wire rope drum, sheaves and method of reeving. Wire rope construction should be 6 X 19 or 6 X 37 IWRC right lay to permit correct installation of wire rope anchor. Refer to Table 3 on page 8 for minimum and maximum recommended wire rope diameters.

**Table 3 Minimum and Maximum Wire Rope Size**

| Model | Minimum |    | Maximum |    |
|-------|---------|----|---------|----|
|       | inch    | mm | inch    | mm |
| FH5   | 5/8     | 16 | 7/8     | 22 |
| FH5T  | 3/4     | 18 |         |    |

Note: Maximum wire rope diameter is limited by the size of the wire rope anchor hole. Refer to the parts list for correct wire rope anchor part numbers.

Smaller wire rope sizes may be acceptable on custom designed drums.

### Installing Wire Rope

Refer to Dwg. MHP0166 on page 8.

1. Cut wire rope to length in accordance with the wire rope manufacturer's instructions.
2. Feed the end of the wire rope into the anchor hole in the drum and pull through approximately one foot (305 mm) of wire rope.

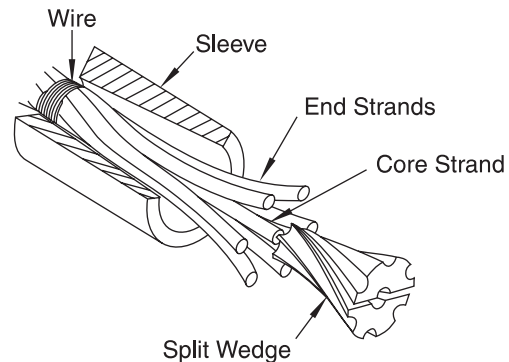

(Dwg. MHP0166)

3. Wrap the wire rope with wire a distance from the end equal to the wedge length plus one inch (25 mm).
4. Slide the sleeve over the end of the wire rope so the larger diameter of the taper bore is nearest the end of the wire rope.
5. Spread the end strands of the wire rope and insert the split wedge until it is below the end of the wire rope.



- Pull the sleeve over the wire rope end until tight. Check that the wire rope strands stay in the slots located on the split wedge.
- Pull the wire rope anchor into position in the drum anchor pocket.

### CAUTION

- Make sure the first wrap of wire rope is tight and lays flush against the drum flange.

#### Safe Wire Rope Handling Procedures

- Always use gloves when handling wire rope.
- Never use wire rope which is frayed or kinked.
- Never use wire rope as a sling.
- Always ensure wire rope is correctly spooled and the first layer is tight against the drum.

#### Wire Rope Spooling

To compensate for uneven spooling and the decrease in line pull capacity as the drum fills up, use as short a wire rope as practical. When rewinding, apply tension to the end of the wire rope to eliminate line slack. This helps achieve level winding and tight spooling.

#### Rigging

Make sure all wire rope blocks, tackle and fasteners have a sufficient safety margin to handle the required load under all conditions. Do not allow wire rope to contact sharp edges or make sharp bends which will cause damage to wire rope. Use a sheave. Refer to the wire rope manufacturer's handbook for proper sizing, use and care of wire rope.

#### Safe Installation Procedures

- Do not use wire rope as a ground (earth) for welding.
- Do not attach a welding electrode to winch or wire rope.
- Never run the wire rope over a sharp edge. Use a correctly sized sheave.
- Always maintain at least three full, tight wraps of wire rope on the drum.

### Hydraulic System

#### Hydraulic Hoses

In order to maintain maximum efficiency of the winch, select the size of hydraulic lines according to the maximum volume of oil to be used. Refer to Table 4 on page 9. If the hydraulic lines used are too small, they may cause excessive back pressure, generating heat and causing inefficiency within the hydraulic system. The sizes in Table 4 are to be used as a guide only. If trouble is experienced due to the use of long hoses, it may be necessary to use hoses which are one size larger.

**Table 4 Hydraulic Hose Recommendations**

| Oil Flow *<br>@ 3000 psig max |         | Pressure Lines<br>(inside diameter) |    |
|-------------------------------|---------|-------------------------------------|----|
| gpm                           | l/min   | inch                                | mm |
| 10-30                         | 27-114  | 1                                   | 26 |
| 31-60                         | 115-227 | 1.25                                | 32 |
| 61-90                         | 228-303 | 1.5                                 | 38 |
| 90-120                        | 304-454 | 1.75                                | 45 |

\* Based on 17 fps (5.2 mps) oil velocity.

#### Hydraulic Fluid

The most frequent cause of malfunction or failure of hydraulic equipment is the presence of contaminants in the hydraulic fluid. Reduce contaminants by using clean hydraulic fluid, and changing the fluid before it deteriorates. When the hydraulic fluid is changed, also clean out the hydraulic reservoir. At a minimum, the required oil cleanliness level is ISO 18/13 or better.

Periodic checks which may be performed by the operator to test hydraulic fluid cleanliness include:

- Check for a major change in color or noticeable thickening, which are signs of severe deterioration and indicate the need to change the fluid.
- Check oil for foaming and aeration which may indicate low oil level in the hydraulic tank, leaks, faulty hydraulic line connections or moisture build-up in the oil.

ISO VG 30, 46 and 68 oils will give good results under normal temperature conditions. The use of an oil having a high viscosity index will minimize cold-start trouble and reduce the length of warm-up periods. A high viscosity index will minimize changes in viscosity with corresponding changes in temperature.

### CAUTION

- Do not substitute synthetic fluids unless it has been determined that winch, motor and hydraulic system seals are compatible.

Use a premium anti-wear (AW) hydraulic fluid in the hydraulic system. The following specifications are intended to serve as a general guide in selecting suitable oils.

**Table 5 Recommended Hydraulic Oil**

| Temperature |                | Recommended Hydraulic Oil  |
|-------------|----------------|--|
| Fahrenheit  | Celsius        |  |
| above 32° F | 0° C           | ISO VG 46<br>(SSU 230-240 @ 100° F)  |
| 0° to 32° F | -17.7° to 0° C | ISO VG 32<br>(SSU 160-165 @ 100° F)  |
| below 0° F  | below -17.7° C | Consult local oil company representative for oil having a maximum viscosity of 7,400 SSU's at the minimum temperature encountered. |

## Filters

Filters should be equipped with dirty filter indicators, which should be checked daily. Replace filters if indicators show filter is dirty. It is also recommended that filters be changed if hydraulic oil is changed or a major component (pump, valve, motor, etc.) is repaired or replaced.

When the winch is installed with its own hydraulic system or when there is no filter in the existing circuit, a partial flow micro-filter should be installed between the control valve and the reservoir. This filter should be rated at Beta 200=6 $\mu$ m. Filters must include an integral 50 psi (345 kPa/3.45 bar) bypass check valve which will open when the filter element is filled to 80% capacity.

Refer to 'Filter Maintenance' in the "MAINTENANCE" section for servicing information.

## Hydraulic Connections

When repairing or servicing any hydraulic lines or fittings in the system, always flush each line and connection of all foreign contaminants before making the final connection. Always cap or plug open connections or lines. Verify port connections match motor and installation information provided.

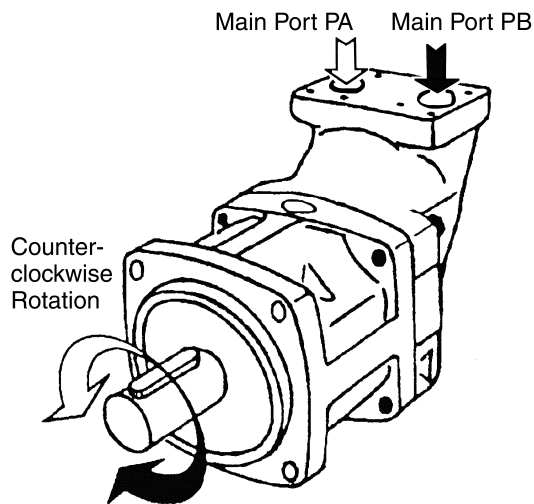

(Dwg. MHP1804)

## Pump

Ensure the pump used with the winch motor is capable of producing pressure and volume as specified for the winch.

## Control Valve

The control valve used to operate the winch must be a four-way, spring return to neutral, open center valve having a motor spool directing all work port flow to the reservoir (return lines) when the valve spool is in the neutral position. This control valve should have good metering characteristics in order to provide smooth winch control. A built-in relief valve, suitable for maximum operating pressure and flow, should also be installed in the control valve and/or hydraulic system.

## Motor

For optimum performance and maximum durability of parts, ensure hydraulic supply does not exceed recommended pressures and flows. When feasible the motor should be installed as near as possible to the pump. Motor case drain lines must be ported to the reservoir and must not exceed 30 psi (207 kPa/2 bar).

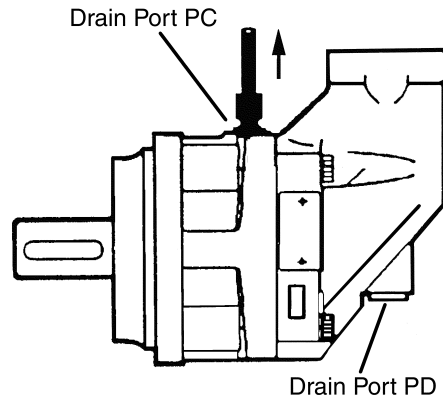

(Dwg. MHP1759)

## Disc Brake

Disc brake is shipped with petroleum based cooling oil installed. Prior to operation, confirm oil level is to manufacturer's recommendations.

## Initial Operating Checks

Winches are tested for proper operation prior to leaving the factory. Before the winch is placed into service the following initial operating checks should be performed.

1. Make sure the hydraulic motor and case drain line is filled with the recommended hydraulic fluid. Internal motor leakage at low operating pressures may not be sufficient to provide start-up lubrication.
2. Verify oil levels are in accordance with recommendations in "LUBRICATION" section. Ensure all installation steps have been followed.
3. When first operating the winch it is recommended that the winch be driven slowly in both directions for a few minutes.

For winches that have been in storage for a period of more than one month the following start-up procedure is required.

1. Give the winch an inspection conforming to the requirements of "Winches Not in Regular Use" in the "INSPECTION" section.
2. Operate the winch for 10 seconds in both directions to prime all lines.
3. The winch is now ready for normal use.

## OPERATION

The four most important aspects of winch operation are:

1. Follow all safety instructions when operating the winch.
2. Allow only people trained in safety and operation of this winch to operate this equipment.
3. Subject each winch to a regular inspection and maintenance procedure.
4. Be aware of the winch capacity and weight of load at all times.

### WARNING

• **The winch is not designed or suitable for lifting, lowering or moving people. Never lift loads over people.**

### CAUTION

• **To avoid damage to the rigging, the structure supporting the rigging and the winch, do not “two-block”\* the end of the wire rope.**

\* Two blocking occurs when the winch wire rope is multi-reeved using two separate blocks which are allowed to come in contact with each other during winch operation. When this occurs, extreme forces are exerted on the wire rope and sheave blocks which may result in equipment and/or rigging failure.

Operators must be physically competent. Operators must have no health condition which might affect their ability to act, and they must have good hearing, vision and depth perception. The winch operator must be carefully instructed in his duties and must understand the operation of the winch, including a study of the manufacturer's literature. The operator must thoroughly understand proper methods of hitching loads and should have a good attitude regarding safety. It is the operator's responsibility to refuse to operate the winch under unsafe conditions.

### Hydraulic System

Efficient operation of the winch requires attention to the hydraulic oil system. The most important elements to ensure proper operation of the hydraulic system are:

1. **Oil Temperature.** The presence of hot fluid in a hydraulic system is a primary cause of poor operation, component failure and system downtime. The fluid used in any hydraulic system is formulated for operation within a temperature range of 32° to 140° F (0° to 60° C). If the temperature is frequently exceeded component and system operation will be degraded.  
Under continuous operating conditions the temperature of the oil at any given point in the hydraulic system should not be allowed to exceed 180° F (82° C).
2. **Oil Cleanliness.** Hydraulic system cleanliness is extremely important to ensure safe, continued operation of components. Dirty or contaminated hydraulic fluid may cause components to break down, operate erratically or damage valuable equipment.

### Warm Up Procedure

### CAUTION

• **A warm up procedure is recommended at each start-up under normal operating conditions, and is essential at ambient temperatures below 40° F (4° C).**

To warm up the hydraulic oil and system, run the pump with the winch control valve in neutral long enough to sufficiently warm up the system.

Once the system has warmed up, operate the winch, without a load, at slow speeds in both directions several times to prime all lines with warm hydraulic fluid.

### Winch Controls

Ensure control valve handle movement is consistent with direction of winch drum rotation. Refer to manufacturer's literature for additional information.

### Winch Brakes

#### Manual Drum Brake (optional feature)

Refer to Dwg. MHP0153 on page 28.

The manual drum brake may be applied by pushing down on the handle (104) and released by pulling up. If the handle is pushed down fully, it should lock in that position and prevent drum rotation, until released by the operator. The brake must be kept properly adjusted to hold the required load. Refer to the “MAINTENANCE” section for adjustment instructions.

#### Automatic Drum Brake (optional feature)

Refer to Dwg. MHP0153 on page 28.

The automatic drum brake is a spring applied, oil released brake which utilizes an oil actuated, spring loaded cylinder (110), that automatically disengages the brake when the motor is operated. Oil pressure in the cylinder overcomes spring pressure to release the brake. When the control valve is placed in the neutral position, the oil in the cylinder (110) drains to tank and the spring automatically engages the brake to prevent drum rotation. The cylinder clevis (107) must be kept properly adjusted to hold the required load.

#### Automatic Disc Brake

The winch brake typically consists of a fail-safe disc brake and a counterbalance valve. The brake is disengaged in the lowering (payout) direction only. In the raise (haul-in) direction, the brake remains engaged, and an internal sprag clutch provides fail-safe load lifting, preventing momentary downward load drifting at the instant the winch control valve (refer to manufacturer's information) is shifted to raise the load. The brake release oil pressure is provided by fluid pressure ported from the winch motor to the brake housing.

The counterbalance valve will prevent a runaway load condition. Should the load try to drop faster than the winch is paying out, over-running the winch motor, the valve will sense a low pressure condition at the motor inlet, and restrict fluid flow from the motor outlet. This creates a fluid back-pressure on the winch motor, causing the motor to quickly slow down, stopping the runaway load.

The counterbalance valve should be preset to operate a minimum of 130% of the maximum oil pressure induced by the rated winch load.

#### **Drum Locking Pin (optional feature)**

Refer to Dwg. MHP0155 on page 30.

The drum locking pin is mounted to the winch on the outboard upright, opposite the motor. It should be engaged if a load is left suspended. The drum lock is operated by rotating a pin between a shallow groove (disengaged) and a deep groove (engaged).

#### **To Engage:**

1. Rotate the drum (80) so that one of the twelve holes in the flange aligns with the locking pin (136). Pull the pull rod (140) out and straight away from the outboard upright (84). Rotate pull rod counterclockwise 90°, aligning pin (135) with the deep groove in gland (138). Release pull rod and ensure locking pin engages and is seated in the drum hole and gland deep groove.

#### **⚠ WARNING**

- **Ensure that all braking mechanisms are engaged and all personnel are clear of the winch load and rigging before disengaging the locking pin.**
- **Extremely difficult locking pin release is an indication that the load is held by the locking pin and the braking mechanisms are not functioning properly. Do not release the locking pin until load control is established.**

#### **To Disengage:**

1. Pull the pull rod (140) out and straight away from the outboard upright (84). Rotate pull rod clockwise 90°. Align pin (135) with the shallow groove in gland (138) and release pull rod. Ensure locking pin (136) is clear of the drum (80) flange and pin is seated in the gland shallow groove.

# LUBRICATION

To ensure continued satisfactory operation of the winch, all points requiring lubrication must be serviced with the correct lubricant at the proper time interval as indicated for each assembly.

The lubrication intervals recommended in this manual are based on intermittent operation of the winch eight hours each day, five days per week. If the winch is operated almost continuously or more than the eight hours each day, more frequent lubrication will be required. Also, the lubricant types and change intervals are based on operation in an environment relatively free of dust, moisture, and corrosive fumes. Use only those lubricants recommended. Other lubricants may affect the performance of the winch. Approval for the use of other lubricants must be obtained from your **Ingersoll-Rand** distributor. Failure to observe this precaution may result in damage to the winch and/or its associated components.

| INTERVAL | LUBRICATION CHECKS                                |
|----------|---|
| Monthly  | Lubricate components supplied by grease fittings. |
|          | Inspect and clean or replace oil filter.          |
|          | Check reduction gear oil level.                   |
| Yearly   | Drain and refill winch reduction gear oil.        |

Note: Intervals are based on winch operation in a normal environment. In 'Heavy' or 'Severe' operating conditions adjust lubrication intervals accordingly.

## Recommended Lubricants

### Reduction Gear Assembly Gear Oil

| Temperature                   | Gear Oil Type          |
|-------------------------------|------------------------|
| -4° to 125° F (-20° to 52° C) | ISO VG 100 (SAE 75W90) |

### Grease

| Temperature                      | Type Grease                               |
|----------------------------------|---|
| -20° to 50° F<br>(-30° to 10° C) | EP 1 multipurpose<br>lithium-based grease |
| 30° to 120° F<br>(-1° to 49° C)  | EP 2 multipurpose<br>lithium-based grease |

## Component Lubrication

### General Lubrication

Correct lubrication is one of the most important factors in maintaining efficient winch operation.

- The recommended grade of oil must be used at all times since the use of unsuitable oil may result in excessive temperature rise, loss of efficiency and possible damage to internal components. Refer to the "Recommended Lubricants" section.
- Drain and replace oil in the reduction gear after the first 50 hours of initial winch operation. Thereafter, drain and replace oil according to the operating environment as defined by the "Periodic Inspection" interval table in the "INSPECTION" section, or more frequently if desired.

- Always inspect removed oil for evidence of internal damage or contamination (metal shavings, dirt, water, etc.). If indications of damage are noted, investigate and correct before returning winch to service.
- After winch operation, allow oil to settle before topping off.
- Always drain oil into a suitable container and dispose of in an environmentally safe manner.

### Oil Capacities

| Component               | Quantity           |
|-------------------------|--------------------|
| Reduction Gear Assembly | 4 qts (3.8 litres) |

### Reduction Gear Assembly

Refer to Dwg. MHP1756 on page 13.

It is recommended that the first oil change be done after approximately 50 hours initial operation. Always inspect removed oil for evidence of internal damage (metal shavings, dirt, water, etc.).

The reduction gear is filled to the correct levels prior to shipment from the factory. Check oil level before initial winch operation. This component is splash lubricated by oil in the housing and has no other means of lubrication. It is therefore important to use high quality Extreme Pressure (EP) rust and oxidation inhibiting gear oil to ensure maximum performance and minimum down time for repair.

## ⚠ CAUTION

- Do not over fill. Excess oil will reduce operating efficiency and increase oil temperature.

To ensure correct performance, highest efficiency and long life, it is essential that the lubricating oil be maintained at the correct level. Rotate the drum until one of the removable plugs is located at top dead center then add oil up to the level plug hole. Oil capacity for the reduction gear assembly is 4 qts (3.8 litres).

### Reduction Gear Lubrication Plug Locations

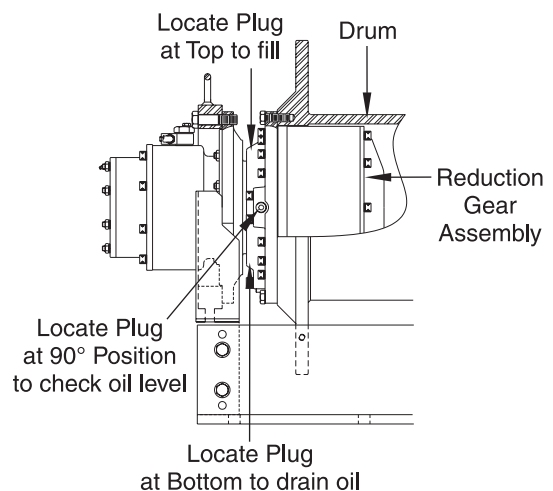

(Dwg. MHP1756)

### Automatic Disc Brake

Refer to the manufacturer's literature for lubrication requirements.

### Seals and Bearings

If winch or components are disassembled, clean all parts thoroughly and coat bearings and seals with clean grease. Refer to "Recommended Lubricants" in this section. Use sufficient grease to provide a good protective coat. Lubricate grease fittings monthly with 2 or 3 pumps of a grease gun.

### Drum Locking Pin (optional feature)

Refer to Dwg. MHP0155 on page 30.  
Lubricate at least once every month, depending on the environment and duty cycle, through grease fitting (139) located in the gland (138) with 2 or 3 pumps of a grease gun.

If drum locking pin is disassembled, clean all parts thoroughly and coat with clean grease. Refer to the 'Recommended Lubricants' section. Use sufficient grease to provide a good protective coat.  
Lubrication will help to prevent rust and allow easier locking pin operation.

### Wire Rope

Follow the wire rope manufacturer's instructions. At a minimum, observe the following guidelines.

1. Clean with a brush or steam to remove dirt, rock dust or other foreign material on the surface of the wire rope.



• **Do not use an acid-based solvent. Only use cleaning fluids and lubricants specified by the wire rope manufacturer.**

2. Apply a wire rope lubricant, **LUBRI-LINK-GREEN®** or an ISO VG 46 oil.
3. Brush, drip or spray lubricant weekly, or more frequently, depending on severity of service.

# INSPECTION

Inspection information is based in part on American National Standards Institute Safety Codes (ASME B30.7).

## ⚠ WARNING

- **All new, altered or modified equipment should be inspected and tested by personnel instructed in safety, operation and maintenance of this equipment to ensure safe operation at rated specifications before placing equipment in service.**
- **Never use a winch that inspection indicates is damaged.**

Frequent and periodic inspections should be performed on equipment in regular service. Frequent inspections are visual examinations performed by operators or personnel trained in safety and operation of this equipment and include observations made during routine equipment operation. Periodic inspections are thorough inspections conducted by personnel trained in safety, operation and maintenance of this equipment. ASME B30.7 states inspection intervals depend upon the nature of the critical components of the equipment and the severity of usage. Careful inspection on a regular basis will reveal potentially dangerous conditions while still in the early stages, allowing corrective action to be taken before the condition becomes dangerous.

Deficiencies revealed through inspection, or noted during operation, must be reported to designated personnel instructed in safety, operation and maintenance of this equipment. A determination as to whether a condition constitutes a safety hazard must be decided, and the correction of noted safety hazards accomplished and documented by written report before placing the equipment in service.

## Records and Reports

Inspection records, listing all points requiring periodic inspection should be maintained for all load bearing equipment. Written reports, based on severity of service, should be made on the condition of critical parts as a method of documenting periodic inspections. These reports should be dated, signed by the person who performed the inspection, and kept on file where they are readily available for review.

## Wire Rope Reports

Records should be maintained as part of a long range wire rope inspection program. Records should include the condition of wire rope removed from service. Accurate records will establish a relationship between visual observations noted during frequent inspections and the actual condition of wire rope as determined by periodic inspections.

## Frequent Inspection

On equipment in continuous service, frequent inspection should be made by operators at the beginning of each shift. In addition, visual inspections should be conducted during regular operation for damage or evidence of malfunction.

1. **WINCH.** Prior to operation, visually inspect winch housings, controls, brakes, side rails and drum for indications of damage. Do not operate the winch unless the wire rope feeds onto the drum smoothly, and any discrepancies noted have been reviewed and inspected further by personnel instructed in the operation, safety and maintenance of this winch.
2. **WIRE ROPE.** Visually inspect all wire rope which can be expected to be in use during the day's operations. Inspect for damage indicated by distortion of wire rope such as kinking, "birdcaging," core protrusion, main strand displacement, corrosion, broken or cut strands. If damage is evident, do not operate winch until the damage has been reviewed and inspected further by personnel instructed in the operation, safety and maintenance of this winch.

## NOTICE

- **The full extent of wire rope wear cannot be determined by visual inspection. At any indication of wear inspect the wire rope in accordance with instructions in "Periodic Inspection."**

3. **HYDRAULIC SYSTEM.** Check hydraulic lines, fittings, valves and other components for deterioration, leakage or wear. Tighten, repair or replace as necessary. Check reservoir sight gauge for proper hydraulic oil level. Check dirt alarms at both pressure and return line filters for visual indication of dirty filter.
4. **CONTROLS.** During operation of winch, verify response to control is quick and smooth. If winch responds slowly or movement is unsatisfactory, do not operate winch until all problems have been corrected.
5. **BRAKES.** During winch operation test brakes. Brakes must hold load without slipping. Automatic brakes must release when winch motor throttle is operated. If brakes do not hold load, or do not release properly, the brakes must be adjusted or repaired.

## Periodic Inspection

Periodic inspection intervals for winch use under various conditions is listed below:

| NORMAL | HEAVY        | SEVERE    |
|--------|--------------|-----------|
| yearly | semiannually | quarterly |

Disassembly may be required as a result of frequent inspection findings or in order to properly inspect the individual components. Disassembly steps are described in the "MAINTENANCE" section. Maintain written records of periodic inspections to provide an accumulative basis for continuing evaluation. Inspect all items listed in "Frequent Inspection." Also inspect the following:

1. **SIDE RAILS and UPRIGHTS.** Check for deformed, cracked or corroded main components. Replace damaged parts.
2. **FASTENERS.** Check retainer rings, split pins, capscrews, nuts, and other fasteners on winch, including mounting bolts. Replace if missing or damaged and tighten if loose.
3. **DRUM AND SHEAVES.** Check for cracks, wear or damage. Replace if necessary.

4. **WIRE ROPE.** In addition to Frequent Inspection requirements, also inspect for the following:
  - a. Build-up of dirt and corrosion. Clean with steam or a stiff wire brush to remove dirt and corrosion if necessary.
  - b. Loose or damaged end connection. Replace if loose or damaged.
  - c. Check wire rope anchor is secure in drum.
  - d. Verify wire rope diameter. Measure the diameter of the wire rope from crown-to-crown throughout the life of the wire rope. Recording of the actual diameter should only be done with the wire rope under equivalent loading and in the same operating section as accomplished during previous inspections. If the actual diameter of the wire rope has decreased more than 1/64 inch (0.4 mm) a thorough examination of the wire rope should be conducted by an experienced inspector to determine the suitability of the wire rope to remain in service. Refer to Dwg. MHP0056 on page 16.

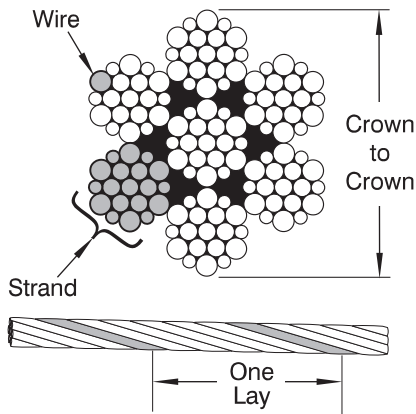

(Dwg. MHP0056)

5. **ALL COMPONENTS.** Inspect for wear, damage, distortion, deformation and cleanliness. If external evidence indicates damage, disassemble as required to conduct a detailed inspection. Inspect gears, shafts, bearings, sheaves, springs and covers. Replace worn or damaged parts. Clean, lubricate and reassemble.
6. **BRAKES.** Individually test brakes installed to ensure proper operation. Brakes must hold a 125% rated load at full drum without slipping. If indicated by poor operation or visual damage, disassemble and repair brake(s). Check all brake surfaces for wear, deformation or foreign deposits. If brake lining thickness is less than minimum, as described in the "MAINTENANCE" section, replace brakes. Clean and replace components as necessary.
7. **FOUNDATION OR SUPPORTING STRUCTURE.** Check for distortion, wear and continued ability to support winch and rated load. Ensure winch is firmly mounted and that fasteners are in good condition and tight.
8. **LABELS AND TAGS.** Check for presence and legibility of labels. Replace if damaged or missing. Refer to 'Labels and Tags' on page 32.
9. **GUARDS (optional feature).** Check guards are in place and secure.

|                                   |
|-----------------------------------|
| <b>Winches Not in Regular Use</b> |
|-----------------------------------|

1. Equipment which has been idle for a period of one month or more, but less than six months, shall be given an inspection conforming to the requirements of "Frequent Inspection" before being placed in service.
2. Equipment which has been idle for a period of over six months shall be given a complete inspection conforming with the requirements of "Periodic Inspection" before being placed in service.
3. Standby equipment shall be inspected at least semiannually in accordance with the requirements of "Frequent Inspection". In abnormal operating conditions equipment should be inspected at shorter intervals.



# INSPECTION AND MAINTENANCE REPORT

## Ingersoll-Rand Force 5 Series Hydraulic Winch

|                      |              |
|----------------------|--------------|
| <b>Model Number:</b> | <b>Date:</b> |
|----------------------|--------------|

|                       |                      |
|-----------------------|----------------------|
| <b>Serial Number:</b> | <b>Inspected By:</b> |
|-----------------------|----------------------|

|  |  |  |
|--|--|--|
| <b>Reason for Inspection: (Check Applicable Box)</b> |  |  |
|  | 1. Scheduled Periodic Inspection:<br>_____ Quarterly _____ Semiannually _____ Yearly | <b>Operating Environment:</b><br><br>Normal _____ Heavy _____ Severe _____ |
|  | 2. Discrepancies noted during Frequent Inspection                                    |  |
|  | 3. Discrepancies noted during Maintenance  |  |
|  | 4. Other: _____  |  |

Refer to the Parts, Operation and Maintenance Manual "INSPECTION" section for general inspection criteria. Also, refer to appropriate National Standards and codes of practice. If in doubt about an existing condition, contact the nearest **Ingersoll-Rand** Distributor or the factory for technical assistance.

| COMPONENT                                | CONDITION |      | CORRECTIVE ACTION |         | NOTES |
|--|-----------|------|-------------------|---------|-------|
|  | Pass      | Fail | Repair            | Replace |       |
| Uprights and Side Rails                  |           |      |                   |         |       |
| Drum Band Brake (125% Load Test)         |           |      |                   |         |       |
| Automatic Disc Brake (125% Load Test)    |           |      |                   |         |       |
| Drum Band Brake (Visual Inspection)      |           |      |                   |         |       |
| Disc Brake (Visual Inspection)           |           |      |                   |         |       |
| Motor                                    |           |      |                   |         |       |
| Limit Switches                           |           |      |                   |         |       |
| Controls                                 |           |      |                   |         |       |
| Fasteners                                |           |      |                   |         |       |
| Reduction Gears                          |           |      |                   |         |       |
| Labels and Tags                          |           |      | ---               |         |       |
| Shafts                                   |           |      |                   |         |       |
| Guards                                   |           |      |                   |         |       |
| Wire Rope Anchor                         |           |      | ---               |         |       |
| Other Components (list in NOTES section) |           |      |                   |         |       |

| TESTING                           | Pass | Fail | NOTES |
|-----------------------------------|------|------|-------|
| Operational (No Load)             |      |      |       |
| Operational (10%)                 |      |      |       |
| Operational (Maximum Test Load *) |      |      |       |

\* Maximum test load is 125% of rated line pull at full drum.

This page may be copied and used as an Inspection/Maintenance Record.

## TROUBLESHOOTING

This section provides basic troubleshooting information. Determination of specific causes to problems are best identified by thorough inspections performed by personnel instructed in safety, operation and maintenance of this equipment. The chart below provides a brief guide to common winch symptoms, probable causes and remedies.

| SYMPTOM  | CAUSE  | REMEDY  |
|--|--|---|
| Load continues to move when winch is stopped.  | Drum brake is slipping.  | Check drum brake adjustment and brake band lining wear.   |
|  | Winch is overloaded.   | Reduce load to within rated capacity.   |
|  | Control valve may not be correct type. The correct control valve should have all ports open to reservoir when the spool is in the neutral position.  | If the motor ports in the valve are blocked by the spool (closed center) when the control valve is in the neutral position, remove valve and replace with correct tandem center (A & B to tank) or float center motor spool (P, A & B to tank) valve.   |
|  | There is excessive back pressure acting on the reverse port of the winch motor and disc brake charge port.   | Install pressure gauges in motor lines. Run the pump at its maximum RPM and, with the control valve in the neutral position, read the pressure gauges. Pressure greater than 140 psig (9.6 bar/9.8 kg/cm <sup>2</sup> ) is too high. Check hose and control valve size. Replace if necessary. |
| Winch does not lift or pull load.  | Motor may be damaged.  | Remove and disassemble motor as recommended by the motor manufacturer. Examine all parts and replace any that are worn or damaged.  |
|  | No oil supply to winch.  | Check oil supply line connections and hoses.  |
|  | Winch is overloaded.   | Reduce load to within rated capacity.   |
|  | Insufficient oil supply.   | Verify oil supply pressure and volume at winch inlet meets the specified requirements. Clean oil filter.  |
|  | Motor variable displacement may be set too low.  | Adjust displacement to a higher setting. Refer to motor manufacturer's literature.  |
|  | System not delivering full pressure to winch.  | Confirm pump is running and on stroke. Check upline flow controls are set as required to run the winch.   |
|  | Relief valve dumps full pressure.  | Confirm no downline restrictions of valves are blocking free flow back to tank.   |
|  | Relief valve set too low.  | Install pressure gauges in motor lines and apply a stall pull on the winch. If pressure is low, increase relief valve setting until recommended pressure is obtained.   |
|  | Relief valve is partially open.  | Remove relief valve and visually inspect and repair or replace worn or damaged parts. Clean all parts thoroughly in a suitable solvent. Reassemble, reinstall and reset relief valve pressure setting.  |
| Oil level in reservoir too low. Suction line may be restricted or have an air leak causing cavitation at the inlet pump. 'Whining' noise at pump is an indication of this problem. | Check oil level in reservoir. Check suction line externally and internally for damage. Replace suction line if damaged. If cavitation has occurred, it is recommended that the pump be disassembled and inspected for worn, pitted and damaged parts. Repair and replace parts as necessary. |   |
| Control lever moves but winch does not operate.  | Motor may be damaged.  | Remove and disassemble motor as recommended by the motor manufacturer. Examine all parts and replace any that are worn or damaged.  |
|  | Insufficient oil supply.   | Verify oil supply pressure and volume at winch inlet meets the specified requirements. Clean oil filter.  |
|  | Drum locking pin (optional feature) is engaged.  | Disengage drum locking pin.   |
| Winch runs slow.   | Improper hose or fitting sizes.  | Check fittings, connections and hoses for correct size and length. Replace parts that may cause restricted oil flow. Inspect oil filter.  |
|  | Motor variable displacement set too high.  | Lower motor variable displacement setting. Refer to motor manufacturer's literature.  |
|  | Motor may be damaged.  | Remove and disassemble motor as recommended by motor manufacturer. Examine all parts and replace any that are worn or damaged.  |

| <b>SYMPTOM</b>   | <b>CAUSE</b>   | <b>REMEDY</b>  |
|--|--|--|
| Lower (payout) speed is slower than lifting (haul-in) speed. | Control valve may be restricted in its travel.   | Check the travel of the control valve spool. The spool travel should be the same in both directions.   |
|  | Oil may be too thick, causing a high resistance to rotation at the brake plates causing relief valve to by-pass. | Change to lighter weight oil in the hydraulic system.  |
|  | Damaged 'O' Ring in brake assembly.  | Disassemble, inspect and replace brake 'O' Rings. Refer to manufacturer's literature for service/maintenance requirements. If allowed by manufacturer, test brake by attaching a pressurizing instrument, such as a 'Porta-Power', to brake port and pressurize to 300 psig (2069 kPa/20.7 bar) (or allowable maximum pressure). Allow brake to hold pressure for an adequate period of time to ensure pressure does not bleed down. |

**Automatic Disc Brake:**

|                         |  |   |
|-------------------------|--|---|
| Brake fails to release. | Low oil supply pressure.               | Ensure the oil pressure at the inlet to the disc brake is at least 300 psig (2069 kPa/20.7 bar).  |
|                         | Worn or damaged piston seals.          | Inspect the brake breather. If oil escapes from the brake breather when attempting to release the brake, the brake seals must be replaced.  |
|                         | No release pressure at the brake port. | Check line between motor and brake.   |
|                         | Sticking brake piston.                 | Apply 300 psig (2069 kPa/20.7 bar) to the brake release port and check for brake disc movement. If brake discs do not move, disassemble and inspect the disc brake as described in the manufacturer's literature. |

**Automatic Drum Brake:**

|                                  |                               |  |
|----------------------------------|-------------------------------|--|
| Brake cylinder will not release. | Drum brake out of adjustment. | Adjust drum brake to maintain correct cylinder stroke. |
|                                  | Damaged cylinder seals.       | Replace or repair cylinder.                            |
|                                  | Plugged return valve.         | Check return valve.                                    |

# MAINTENANCE

## ⚠ WARNING

- Never perform maintenance on the winch while it is supporting a load.
- Before performing maintenance, tag controls:  
**DANGER - DO NOT OPERATE - EQUIPMENT BEING REPAIRED**
- Only allow personnel trained in safety and maintenance on this winch to perform service.
- After performing any maintenance on the winch, test winch to 125% of its rated capacity before returning to service. Testing to more than 125% of rated capacity may be required to comply with standards outside the USA.
- Turn off system and depressurize lines before performing any maintenance.

### Maintenance Intervals

The Maintenance Interval chart is based on intermittent operation of the winch eight hours each day, five days per week. If winch operation is more than eight hours per day, or in HEAVY or SEVERE environments, more frequent maintenance should be performed. Refer to “Periodic Inspection” in the “INSPECTION” section for additional information.

| INTERVAL   | MAINTENANCE CHECK   |
|--|---|
| Start of each shift<br><br>(Operator or Maintenance Personnel) | Make a thorough visual inspection of the winch for damage. Do not operate the winch if damaged.<br><br>Operate the winch at low RPM in both directions. Winch must operate smoothly without sticking, binding or abnormal noises. Check the operation of the brake(s).              |
| 3 Months<br><br>(Maintenance Personnel)                        | Inspect the drum brake friction linings. Clean or replace parts as required. Adjust drum brake as necessary.  |
| Yearly<br><br>(Maintenance Personnel)                          | Inspect the winch gearing, shafts and bearings for wear and damage. Repair or replace as necessary.<br><br>Check all the supporting members, including the foundation, fasteners, nuts, sheaves and rigging, etc. for indications of damage or wear. Repair or replace as required. |

### Reduction Gear Assembly

It is recommended that the first oil change be done after approximately 50 hours initial operation. Always inspect removed oil for evidence of internal damage (metal shavings, dirt, water, etc.).

Check the oil in the reduction housing as recommended in the “LUBRICATION” section. If low, replenish. The oil should be changed at least once every year. Refer to the “LUBRICATION” section for recommended oil.

### Adjustments

#### Automatic Disc Brake Adjustment

Disc brake adjustment is not required. If the disc brake does not hold the rated load disassemble and repair. Refer to manufacturer’s literature for service and maintenance requirements.

#### Manual Drum Brake Adjustment

Refer to Dwg. MHP0153 on page 28.

1. Release wire rope tension on the drum.
2. Raise handle (104) to free brake bands (128).
3. Remove cotter pin (102) and pin (101).
4. Rotate link stud (103) clockwise to increase brake torque.
5. Install pin (101) and check adjustment.
6. Brake should be adjusted until brake lever over center position can be attained with 50 to 100 lb. (23 to 45 kg) force on the handle (104).
7. Install cotter pin (102) when adjustment is completed.

## ⚠ CAUTION

- When any part of the brake lining measures 0.062 inch (2 mm) or less, brake bands (128) or linings must be replaced.

#### Automatic Drum Brake Adjustment

Refer to Dwg. MHP0153 on page 28.

1. Remove cotter pin (102) and washer (129) at adjustment clevis (107).
2. Apply oil pressure to the brake cylinder (110) and remove pin (106) and second washer (129) to disconnect clevis from brake lever (105).
3. Turn adjustment clevis (107) clockwise to increase cylinder rod extension. Turn clevis counterclockwise to decrease cylinder rod extension.
4. Assemble clevis (107) to brake lever (105) with washer (129) and pin (106). Release oil pressure to brake cylinder (110).
5. Measure cylinder rod extension. Length should be 1 to 1-1/2 inches (52 to 65 mm). Readjust if necessary.
6. Install cotter pin (102) and second washer (129) to secure clevis to brake lever when adjustment is complete.
7. With brake “On”, adjust screw (127) to just touch arm (124).

### Hydraulic System General Maintenance

Hydraulic systems operate efficiently when properly maintained. The following information should be developed into a routine maintenance procedure to ensure the hydraulic system and components operate efficiently.

#### Hydraulic Motor

Inspect as recommended by motor manufacturer. Establish a schedule as part of an overall maintenance schedule.

## Reservoir

Maintain fluid level at all times. The fluid should be checked after the first 10 hours of initial operation. If satisfactory, routine checks should be made each 100 hours of operation to verify that the fluid (class and type) meets the requirements of the pump.

Change fluid every 1000 to 2000 hours of operation depending upon severity of application and operating environment. If manufacturer's requirements recommend fluid changes sooner, follow those recommendations.

## Spare Parts

Spare filter elements should be available to allow filter replacement as necessary to maintain a clean hydraulic oil supply.

Other spare parts (hoses, fittings, etc.) should also be available to limit equipment downtime in the event that repairs are necessary.

## Cleanliness

Keep equipment clean. A thick layer of dirt acts as insulation, causing the hydraulic system to retain heat resulting in higher operating temperatures.

If the system is opened for inspection or repair, a clean work area prevents foreign contaminants from entering the system and damaging component internal parts.

## Filter Maintenance

**Filters must be maintained.** The key to good filtration is effective filter maintenance. Check filter condition frequently. Keep a record of how often filters need replacing and use this record to establish a service schedule. Routinely replacing the filter before it affects operation of the winch reduces unexpected downtime and potential wear. A system may be equipped with the best filters available, and the filters positioned properly so they can do the most good, but, if the filters are not replaced when dirty, the money spent for the filters and their installation will have been wasted. A filter that gets dirty after 1 day of service and then is not cleaned until 29 days later allows 29 days of unfiltered fluid. A filter is only as good as the maintenance given to it.

### Service Suggestions:

1. Set up a filter maintenance schedule and follow it carefully.
2. Replace the original filter cartridge after 50 hours of operation.
3. Change or clean filters as required or indicated by visual indicators on filters supplied with such devices.
  - a. Average Operating Environment - replace filter cartridge after each 500 hours of operation.
  - b. Dirty Operating Environment - replace filter cartridge after each 250 hours of operation.
4. Clean suction strainers after first 10 hours of operation and every 100 hours thereafter.
5. Inspect filter elements that have been removed from the system for signs of other system damage.
6. Do not return to the system any fluid that has leaked out.
7. Always keep supplies of fresh fluid covered tightly.
8. Use clean containers, hoses and funnels when filling reservoir. Use of a filter cart when adding fluid is highly recommended.
9. Use common sense precautions to prevent entry of dirt into components that have been temporarily removed from the system.

10. Make sure that all clean-out holes, filler caps and breather cap filters on the reservoir are properly fastened.
11. Do not run the system unless all normally provided filtration devices are in place.
12. Make certain that the fluid used in the system is a type recommended by the manufacturers' of the system or components.

The above recommendations are based on an open system equipped with micro-air breathers. Open systems without micro-air breathers are not recommended. Visual inspection cannot be used to determine cartridge replacement. Particles below 40 microns are not visible to the human eye.

Before changing from one type of fluid to another (for example, from a petroleum-base to a fire-resistant fluid) consult component and filter manufacturers on the selection of the fluid and the filters that should be used. Follow recommended flushing procedures when changing fluids. Also consult ANSI B93.5M-1979 "Practice for the Use of Fire Resistant Fluids for Industrial Hydraulic Fluid Power Systems."

## Disassembly

### General Disassembly Instructions

The following instructions provide the necessary information to disassemble, inspect, repair, and assemble the winch. Parts drawings are provided in the parts section.

If a winch is being completely disassembled for any reason, follow the order of the topics as they are presented.

It is recommended that all maintenance work on the winch be performed in a clean dust-free work area.

In the process of disassembling the winch, observe the following:

1. Never disassemble the winch any further than is necessary to accomplish the needed repair. A good part can be damaged during the course of disassembly.
2. Never use excessive force when removing parts. Tapping gently around the perimeter of a cover or housing with a plastic mallet, for example, is sufficient to break the seal.
3. Do not heat a part with a flame to free it for removal, unless the part being heated is already worn or damaged beyond repair and no additional damage will occur to other parts.

In general, the winch is designed to permit easy disassembly and assembly. The use of heat or excessive force should not be required.

4. Keep the work area as clean as practical, to prevent dirt and other foreign matter from getting into bearings or other moving parts.
5. All seals and 'O' rings should be discarded once they have been removed. New seals and 'O' rings should be used when assembling the winch.
6. When grasping a part in a vise, always use leather-covered or copper-covered vise jaws to protect the surface of the part and help prevent distortion. This is particularly true of threaded members, machined surfaces and housings.
7. Do not remove any part which is a press fit in or on a subassembly unless the removal of that part is necessary for repairs or replacement.
8. When removing ball bearings from shafts, it is best to use a bearing puller. When removing bearings from housings, drive out the bearing with a sleeve slightly smaller than the outside diameter of the bearing. The end of the sleeve or pipe which contacts the bearing must be square. Protect bearings from dirt by keeping them wrapped in clean cloths.

## Removing Winch

1. Remove the wire rope from the drum.
2. Operate the winch to position reduction gear drain plug at its lowest position.
3. Relieve pressure in the hydraulic lines by operating the winch control several times after the pump has been disconnected.

## WARNING

• **Shut off, bleed down and disconnect the hydraulic supply line before performing any disassembly procedures.**  
• **The weight of a winch with a 24 inch long drum and no wire rope could exceed 2000 lbs (907 kgs). Exercise caution when lifting and moving winch.**

4. Disconnect and tag the hydraulic lines.
5. Remove the winch from its mounting and take to a suitable work area before beginning disassembly.
6. Drain oil from the reduction gear assembly by removing one plug when positioned at its lowest point and one plug from highest point to vent. Refer to Dwg. MHP1756 on page 13 in the "LUBRICATION" section. If the winch is equipped with a drum band brake the winch outboard end (opposite the motor end) must be elevated to prevent draining oil from contaminating the brake band lining.
7. For winches with a disc brake remove pipe plug in brake housing to drain oil.
8. Remove drum band brake, drum guard and any other externally mounted winch attachments.

## Motor Removal

1. Disconnect case drain line from motor or cartridge valve manifold.
2. Disconnect both main motor port lines.
3. Loosen and remove four motor mounting capscrews (45) and lockwashers (46).
4. Carefully extract the motor (motor and manifold assembly) from the disc brake, paying special attention not to damage motor shaft splines. Pay careful attention that the disc brake assembly does not slide out.

## Manual or Automatic Drum Brake Disassembly

Refer to Dwg. MHP0153 on page 28.

1. Automatic Brake:
  - a. Disconnect and remove hose, fittings and dump valve (112) from the cylinder (110).
  - b. Remove cotter pin (102) and pin (101) from the link stud (103) and brake band (128).
  - c. Remove cotter pin (102), washers (129) and pin (106). Separate the clevis (107) from brake lever (105).
  - d. Remove cotter pin (102) and pin (134). Remove cylinder (110) from bracket (118).
2. Manual Brake:
  - a. Remove cotter pin (102) and pin (101) from handle (104) then remove handle (104) from brake band (128).
3. Remove capscrews (119), lockwashers (117) and stop plate (126).
4. Use a hoist to raise the winch approximately 6 in. (15 cm). Separate the brake band (128) halves and rotate the brake band assembly slowly until it can be removed from the drum (80).

5. Remove cotter pins (102) and pins (121) so brake band halves (128) can be removed from the arm (124). Lower winch when brake band assembly has been removed.
6. Refer to 'Brake Lining Instruction Sheet' (Form MHD56142) for brake lining replacement procedures.

## Drum/Reducer Removal

Refer to Dwg. MHP1777 on page 26.

1. Remove capscrews (85) and lockwashers (86) which secure the side rails (82) and (83) to the inboard upright (42). Drive out dowel pins (87).
2. Remove capscrews (45) and lockwashers (46) which secure reducer/brake assembly (5) to drum (80).
3. Remove inboard upright (42) with attached reducer/brake assembly (5).
4. Remove end cover (95), capscrews (97) and lockwashers (96) from outboard upright (84).
5. Remove capscrews (93) and shaft retainer (92) from the drum (80).
6. Remove drum from outboard upright (84).
7. Remove the remaining capscrews (85) and lockwashers (86) which attach the side rails (82) and (83) to the outboard upright (84). Drive out dowel pins (87).
8. Remove bearing (49) and seal (99) from outboard upright (84).
9. Remove capscrews (39) and (45) and lockwashers (3) securing the reducer/brake assembly (5) to the inboard upright (42).
10. Remove reducer/brake assembly (5) from the inboard upright (42). Refer to manufacturer's literature for reducer/brake maintenance instructions.

## Cleaning, Inspection and Repair

### Cleaning

Clean all winch component parts in solvent (except the drum brake bands and disc brake friction plates). The use of a stiff bristle brush will facilitate the removal of accumulated dirt and sediments on the housings, frame and drum. If bushings have been removed it may be necessary to carefully remove old Loctite® from the bushing bores. Dry each part using low pressure, filtered compressed air. Clean the drum brake band using a wire brush or emery cloth. Do not wash the drum brake band in liquid. If the drum brake band lining is oil-soaked, it must be replaced.

### Inspection

All disassembled parts should be inspected to determine their fitness for continued use. Pay particular attention to the following:

1. Inspect all gears for worn, cracked, or broken teeth.
2. Inspect all bushings for galling, scoring, or galling.
3. Inspect shafts for ridges caused by wear. If ridges caused by wear are apparent on shafts, replace the shaft.
4. Inspect all threaded items and replace those having damaged threads.
5. Inspect the drum band brake lining for oil, grease and glazing. If the drum band brake lining is oil-soaked replace the brake bands as a set. Remove glazed areas of band brake lining by sanding lightly with a fine grit emery cloth.
6. Measure the thickness of the drum band brake lining. If the drum brake band lining thickness is less than 0.062 inch (2 mm) anywhere along the edges, replace the brake bands (128) as a set.

## Repair

Actual repairs are limited to the removal of small burrs and other minor surface imperfections from gears and shafts. Use a fine stone or emery cloth for this work.

1. Worn or damaged parts must be replaced. Refer to the applicable parts listing for specific replacement parts information.
2. Inspect all remaining parts for evidence of damage. Replace or repair any part which is in questionable condition. The cost of the part is often minor in comparison with the cost of redoing the job.
3. Smooth out all nicks, burrs, or galled spots on shafts, bores, pins, or bushings.
4. Examine all gear teeth carefully, and remove nicks or burrs.
5. Polish the edges of all shaft shoulders to remove small nicks which may have been caused during handling.
6. Remove all nicks and burrs caused by lockwashers.

## Assembly

### General instructions

1. Use all new gaskets and seals.
2. Replace worn parts.
3. Assemble parts using match marks attached during disassembly. Compare replacement parts with originals to identify installation alignments.
4. Lubricate all internal parts with a mixture of half oil (as recommended in the "LUBRICATION" section) and half molybdenum disulfide lubricant compound (e.g. STP).
5. When torquing capscrews and the pattern contains over three capscrews, use a crossing tightening sequence. Refer to Dwg. MHP0990 on page 23.
6. Tighten capscrews in three steps to prevent warping and provide a tight seal.
  - a. Snug all capscrews.
  - b. Tighten all capscrews to 1/2 final torque value (using a crossing pattern).
  - c. Tighten to final torque (using a crossing pattern).

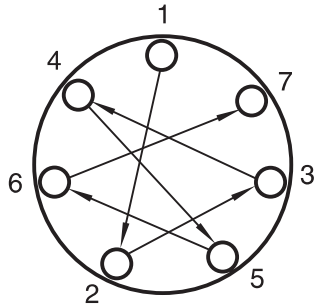

(Dwg. MHP0990)

## Drum/Reducer Assembly

Refer to Dwg. MHP1777 on page 26.

1. Stand drum in an upright position. Apply Loctite® 515 to bolt circle surface. Carefully lower reducer/brake assembly (5) into drum (80).
2. Secure the reducer/brake assembly in the drum with capscrews (45) and lockwashers (3). Lightly coat capscrew threads with Loctite® 242. Torque to 144 ft lbs (195 Nm). Set complete assembly in a horizontal position.

3. Clean seal surfaces and install seal (99) in outboard upright (84). Ensure seal lip is toward drum.
4. Pack bearing (49) with grease and install in outboard upright (84).
5. Install outboard upright (84) on the drum end. Ensure assembly is kept centered on seal and journal during this step.
6. Install shaft retainer (92). Secure by installing three capscrews (93). Lightly coat capscrew threads with Loctite® 242. Torque to 30 ft lbs (41 Nm).
7. Install spacer (91).
8. Apply a light coat of Loctite® 515 sealant to the mating surface of the outboard upright (84) and install end cover (95). Secure using six capscrews (97) and lockwashers (96). Lightly coat capscrew threads with Loctite® 242. Torque to 30 ft lbs (41 Nm).
9. Install pipe plug (98) in end cover (95).
10. Install inboard upright (42) onto reducer/brake assembly (5) and secure with capscrews (4) and (39) and lockwashers (3). Lightly coat capscrew threads with Loctite® 242. Torque to 266 ft lbs (361 Nm).
11. Install side rails (82 and 83) to uprights (42 and 84) and loosely secure using capscrews (85) and lockwashers (86).
12. Tap dowel pins (87) into position until flush with the side rails.
13. Tighten the eight capscrews (85) evenly. Torque to 140 ft lbs (190 Nm).
14. Mount winch to foundation as described in 'Mounting' in the "INSTALLATION" section.

## Drum Brake Assembly

Refer to Dwg. MHP0153 on page 28.

1. Install pivot bracket (122) on the end of arm (124) with pin (121) and cotter pin (102). Recessed side of the threaded hole must be toward the band side.
2. Install connecting link (125) on the arm (124) and secure in position with pin (121), washer (123) and cotter pin (102). Assemble connecting link (125) so curved surface matches contour of the brake band.
3. Install halves of brake band (128) to the connecting link (125) and secure with pins (101), (121) and cotter pins (102).
4. Lift the winch assembly, with a suitable hoist, approximately 6 inches (15 cm) off the floor or work bench.
5. Position the brake band subassembly around the brake diameter on the drum (80) until the arm (124) lies at the bottom. When positioned, lower the winch.
6. Mount pivot bracket (122) on the inside surface of the side rail (83) and secure in position with capscrews (116) and lockwashers (117).
7. Screw link stud (103) into handle (104) and install the handle (104) in the lug on the end of the brake band (128). Lubricate the pivot points, being careful not to get grease on the brake band lining.
8. Pull the halves of the brake band together and install pin (101) through the lug on band (128) and the link stud (103) of the handle assembly.
9. Install stop plate (126) on the inside of the side rail (82) with capscrew (119) and washer (117). Install adjusting screw (127) and locknut (120) through the side rail (82) and stop plate (126) until it contacts the arm (124). Refer to Dwg. MHP0173 on page 24.

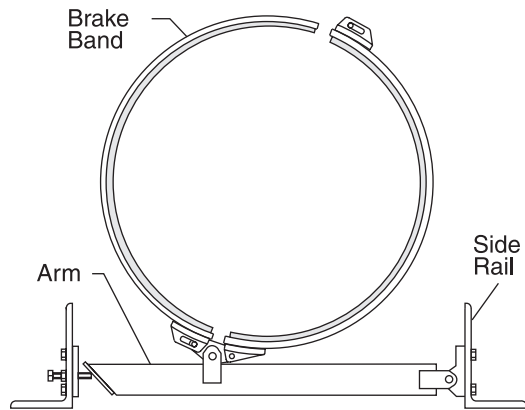

(Dwg. MHP0173)

On **FH5T** winches install stop plate (126) at the top edge of the side rail (82). Refer to Dwg. MHP0174 on page 24.

- Adjust brake as described under 'Adjustments' in the "MAINTENANCE" section.

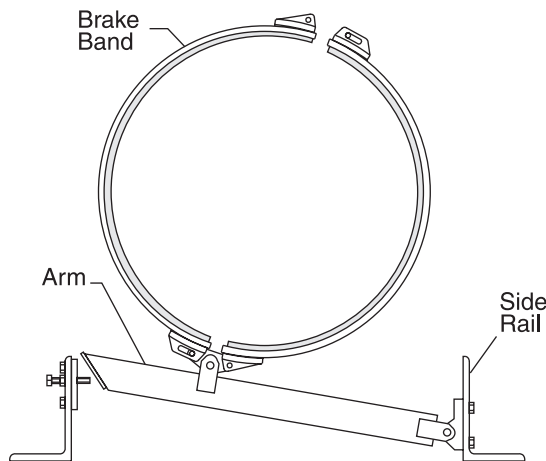

(Dwg. MHP0174)

#### Automatic Drum Brake Actuator Assembly

- Install bracket (118) on side rail (83) with capscrews (116) and lockwashers (117).
- Screw nut (108) and clevis (107) onto cylinder rod.
- Attach brake lever (105) to brake band (128).
- Install cylinder (110) so it connects with bracket (118) and brake lever (105). Use pins (106) and (134), washers (129) and cotter pins (102) to secure in position.
- Install dump valve (112), fittings and hose (113), (114) and (115) to the cylinder (110).
- Adjust automatic brake as described under 'Adjustments' in the "MAINTENANCE" section.

#### Motor Installation

- Apply Loctite® 767 to motor splines. Carefully install motor on disc brake housing. Ensure motor splines are aligned.
- Install capscrews (45) and lockwashers (46) to secure.

#### Testing

#### Operational Test

Prior to initial use, all new, altered or repaired winches shall be tested to ensure proper operation.

- Check oil level in reduction gear assembly and disc brake are correct. Top off levels as required before operation as described in the "LUBRICATION" section.
- Run winch with no load. Confirm leak-free connections.
- Install 0-3,000 psi (0-207 bar) pressure gauges with gauge snubbers teed into the winch at or near the motor A and B ports. Run winch with no load. Record pressure in both directions. Confirm winch hauls in when pulling throttle, and pays out when pushing throttle. Ensure controls operate smoothly and winch responds without sticking, binding or hesitation.
- New Drum Brake Band Lining Run-in Procedure: All new drum brake band linings require a 'run-in' period. Operate the winch without load in the payout direction while gradually applying the brake. Allow the brake to slip for approximately one minute. Winch motor may stall as drum brake band lining fully engages. Do not allow brake to overheat.
- Check operation of brakes. Adjust band brake if necessary as described in the "MAINTENANCE" section.
- Check operation of limit switches, locking mechanisms and all safety devices when equipped.
- Check foundation mounting fasteners are secure.
- Install drum guard when provided.

#### Load Test

Prior to initial use, all new, extensively repaired, or altered winches shall be load tested by or under the direction of a person knowledgeable in the operation of this winch and a written report furnished confirming the rating of the winch. Test loads shall not be less than 100% of rated line pull and should not exceed 125% of the rated line pull. Testing to more than 125% of rated capacity may be required to comply with standards outside the USA.



## FH5 WINCH ASSEMBLY DRAWINGS REFERENCE DIAGRAM

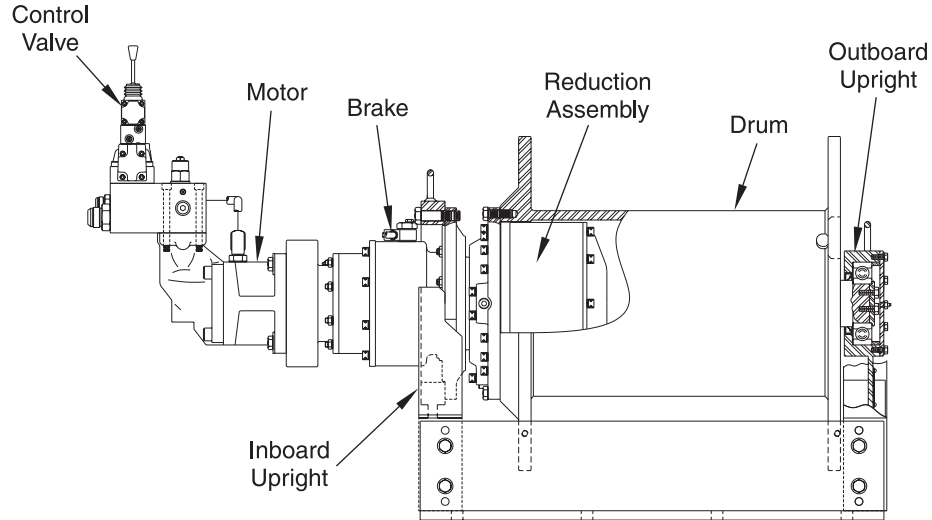

(Dwg. MHP1757)

## FH5 WINCH DRAWINGS AND PARTS LISTS TABLE OF CONTENTS

| Description  | Page No. |
|--|----------|
| Drum, Base and Reduction Gear Assembly Drawing ( <b>MHP1777</b> ) and Parts List . . . . . | 26       |
| Drum, Base and Reduction Gear Assembly Drawing Parts List (continued) . . . . .            | 27       |
| Drum Brake Assembly Drawing ( <b>MHP0153</b> ) . . . . .                                   | 28       |
| Drum Brake Assembly Parts List . . . . .   | 29       |
| Drum Locking Pin (optional) Assembly Drawing ( <b>MHP0155</b> ) and Parts List . . . . .   | 30       |
| Drum Guard Assembly Drawing ( <b>MHP0154</b> ) and Parts List . . . . .                    | 31       |
| Labels and Tags Location Drawing ( <b>MHP1758</b> ) and Parts List . . . . .               | 32       |
| Accessories Parts List . . . . .   | 32       |
| Parts Ordering Information . . . . .   | 33       |
| Warranty . . . . .   | 35       |

# DRUM, BASE AND REDUCTION GEAR ASSEMBLY DRAWING AND PARTS LIST

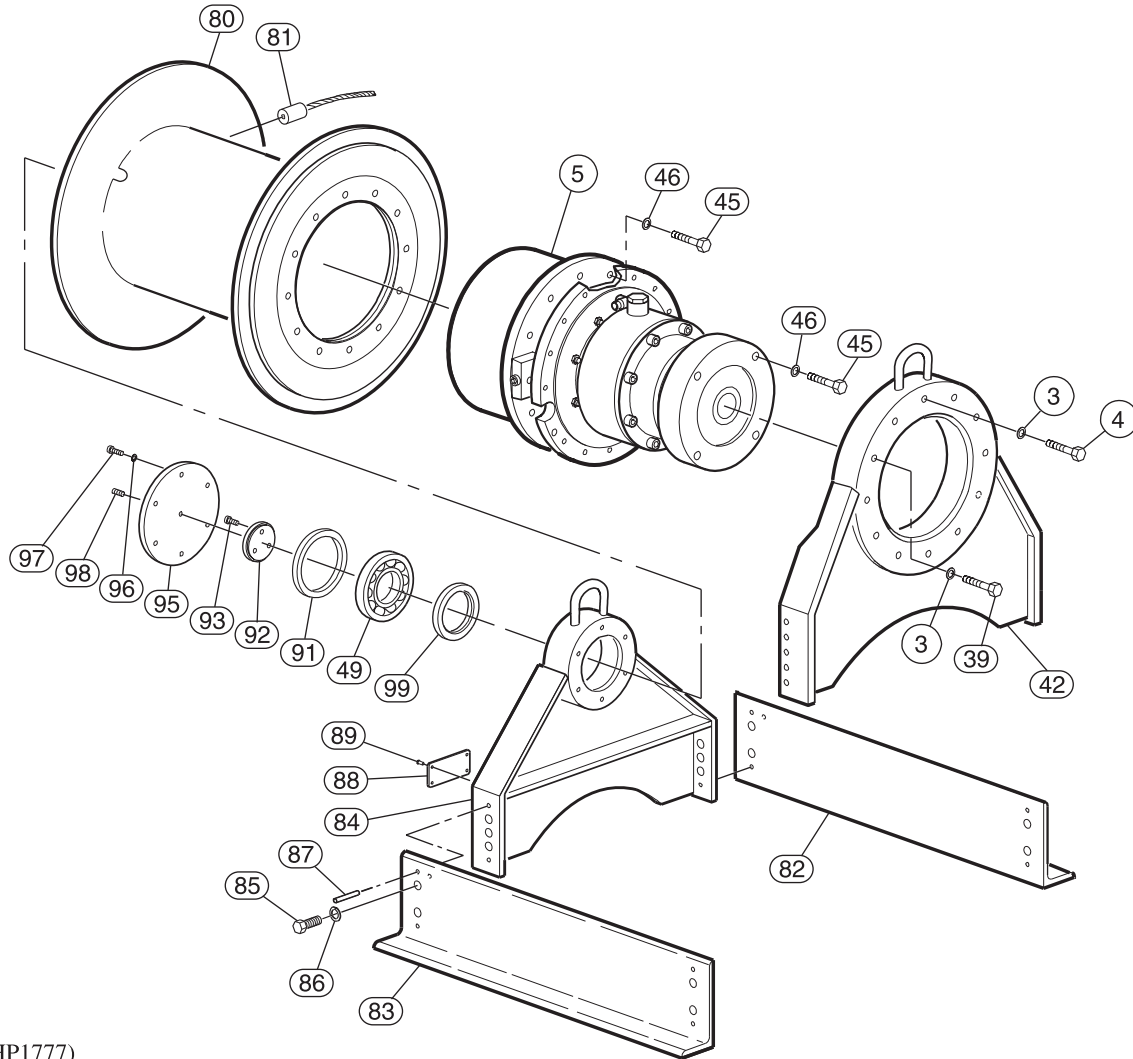

(Dwg. MHP1777)

## SIDE RAIL PARTS LIST

| SIDE RAIL (ITEM 82)<br>RIGHT HAND             | QTY<br>TOTAL | PART<br>NUMBER | SIDE RAIL (ITEM 83)<br>LEFT HAND | QTY<br>TOTAL | PART<br>NUMBER |
|---|--------------|----------------|----------------------------------|--------------|----------------|
| <b>Side Rail for drum with band brake:</b>    |              |                |                                  |              |                |
| with 12 inch Drum †                           | 1            | 11381-2        | with 12 inch Drum †              | 1            | 11385-2        |
| with 16 inch Drum †                           |              | 11381-3        | with 16 inch Drum †              |              | 11385-3        |
| with 24 inch Drum †                           |              | 11381-5        | with 24 inch Drum †              |              | 11385-5        |
| with 30 inch Drum †                           |              | 11381-6        | with 30 inch Drum †              |              | 11385-6        |
| <b>Side Rail for drum without band brake:</b> |              |                |                                  |              |                |
| with 12 inch Drum †                           | 1            | 11386-2        | with 12 inch Drum †              | 1            | 11386-2        |
| with 16 inch Drum †                           |              | 11386-3        | with 16 inch Drum †              |              | 11386-3        |
| with 24 inch Drum †                           |              | 11386-5        | with 24 inch Drum †              |              | 11386-5        |
| with 30 inch Drum †                           |              | 11386-6        | with 30 inch Drum †              |              | 11386-6        |
| with 36 inch Drum †                           |              | 11386-9        | with 36 inch Drum †              |              | 11386-9        |

† These parts also come in a cold weather version. For winches with a —C in the model code, adding CH to the end of these part numbers is required to retain winch certification. Example: Order Side Rail (12 inches long) (item 82) part number 11381-2 as part number 11381-2CH.

## DRUM, BASE AND REDUCTION GEAR ASSEMBLY PARTS LIST

| ITEM NO. | DESCRIPTION OF PART                    | QTY. TOTAL | PART NUMBER | ITEM NO. | DESCRIPTION OF PART     | QTY. TOTAL | PART NUMBER |
|----------|--|------------|-------------|----------|-------------------------|------------|-------------|
| 3        | Washer                                 | 12         | 71350995    | 83       | Side Rail (Back - LH) † | 1          | *           |
| 4        | Capscrew                               | 1          | 71351019    | 84       | Outboard Upright †      | 1          | *           |
| 5        | Reducer/Brake Assembly (ratio 83.99:1) | 1          | 71346514    | 85       | Capscrew                | 8          | 50872       |
|          |  |            |             | 86       | Washer                  | 8          | 50203       |
| 39       | Capscrew                               | 11         | 71349401    | 87       | Dowel Pin               | 8          | 51468       |
| 42       | Upright, Inboard †                     | 1          | *           | 88       | Nameplate               | 1          | 71106967-R  |
| 45       | Capscrew                               | 20         | 71349393    | 89       | Screw, Drive            | 4          | 71028849    |
| 46       | Washer                                 | 20         | 71350607    | 91       | Spacer                  | 1          | 15458       |
| • 49     | Bearing                                | 1          | 51455       | 92       | Shaft Retainer          | 1          | 15457       |
| 80       | Drum                                   | 1          | *           | 93       | Capscrew                | 3          | 51086       |
| 81       | Wire Rope Anchors:                     |            |             | 95       | End Cover               | 1          | 15459       |
|          | 5/8 inch (16 mm)                       | 1          | 52306       | 96       | Lockwasher              | 6          | 50200       |
|          | 3/4 inch (19 mm)                       |            | 52000       | 97       | Capscrew                | 6          | 51780       |
|          | 7/8 inch (22 mm)                       |            | 52308       | 98       | Plug                    | 1          | 54292       |
| 82       | Side Rail (Front - RH) †               |            | 1           | *        | • 99                    | Oil Seal   | 1           |

• Recommended spare

\* Refer to UPRIGHT ASSEMBLY PARTS LIST, DRUM ASSEMBLY PARTS LIST and SIDE RAIL ASSEMBLY PARTS LIST for parts information. RH = Right Hand Side, LH = Left Hand Side as viewed from the winch motor end. Inboard is end closest to motor; outboard is end farthest away from motor.

### UPRIGHT ASSEMBLY PARTS LIST

| INBOARD UPRIGHT (ITEM 42)        | QTY TOTAL | PART NUMBER     | OUTBOARD UPRIGHT (ITEM 84)       | QTY TOTAL | PART NUMBER |
|----------------------------------|-----------|-----------------|----------------------------------|-----------|-------------|
| Standard Drum Flange (27 inch) † | 1         | Contact Factory | Standard Drum Flange (27 inch) † | 1         | 10790       |
| Tall Drum Flange (35 inch) †     |           |                 | Tall Drum Flange (35 inch) †     |           | 10788       |

### DRUM ASSEMBLY PARTS LIST

| DRUM (ITEM 80) WITH BAND BRAKE | QTY TOTAL | PART NUMBER | DRUM (ITEM 80) WITHOUT BAND BRAKE | QTY TOTAL | PART NUMBER |
|--------------------------------|-----------|-------------|-----------------------------------|-----------|-------------|
|--------------------------------|-----------|-------------|-----------------------------------|-----------|-------------|

#### Drum - Standard Flange Height (27 inches):

|                         |   |                 |                         |   |                 |
|-------------------------|---|-----------------|-------------------------|---|-----------------|
| Drum (12 inches long) † | 1 | Contact Factory | Drum (12 inches long) † | 1 | Contact Factory |
| Drum (16 inches long) † |   |                 | Drum (16 inches long) † |   |                 |
| Drum (24 inches long) † |   |                 | Drum (24 inches long) † |   |                 |
| Drum (30 inches long) † |   |                 | Drum (30 inches long) † |   |                 |

#### Drum - Tall Flange Height (35 inches):

|                         |   |                 |                         |   |                 |
|-------------------------|---|-----------------|-------------------------|---|-----------------|
| Drum (12 inches long) † | 1 | Contact Factory | Drum (12 inches long) † | 1 | Contact Factory |
| Drum (16 inches long) † |   |                 | Drum (16 inches long) † |   |                 |
| Drum (24 inches long) † |   |                 | Drum (24 inches long) † |   |                 |
| Drum (30 inches long) † |   |                 | Drum (30 inches long) † |   |                 |
| Drum (36 inches long) † |   |                 | Drum (36 inches long) † |   |                 |

† These parts also come in a cold weather version. For winches with a —C in the model code, adding CH to the end of these part numbers is required to retain winch certification. Example: Order Outboard Upright (item 84) part number 10790 as part number 10790CH.

# DRUM BRAKE ASSEMBLY PARTS

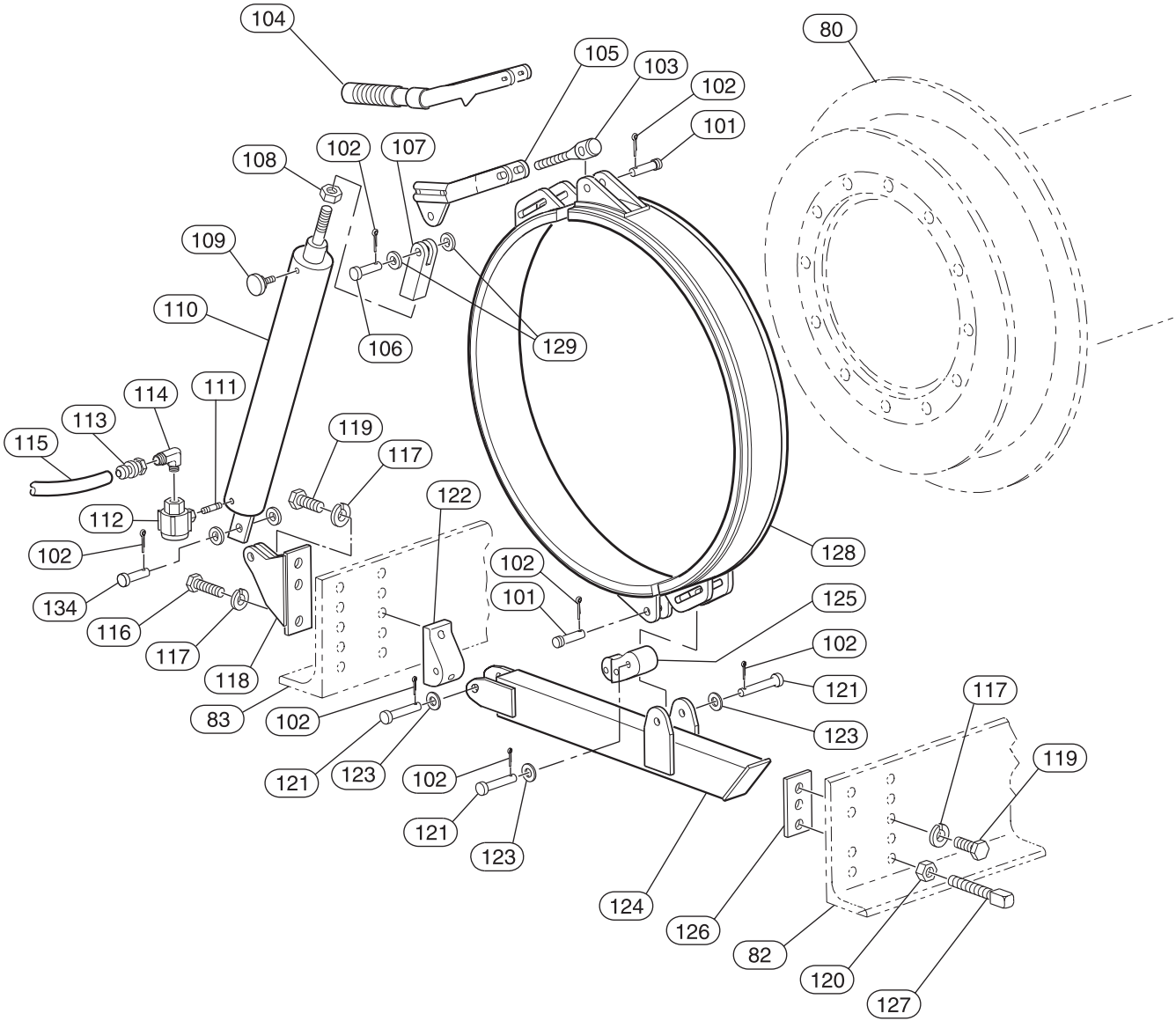

(Dwg. MHP0153)

## DRUM BRAKE ASSEMBLY PARTS LIST

| ITEM NO. | DESCRIPTION OF PART    | QTY. TOTAL | PART NUMBER      |                 |
|----------|------------------------|------------|------------------|-----------------|
|          |                        |            | MANUAL BRAKE     | AUTOMATIC BRAKE |
| 80       | Drum with band brake † | 1          | Refer to Page 27 |                 |

**Tall 35 inch flange:**

|    |                         |   |                  |  |
|----|-------------------------|---|------------------|--|
| 82 | Side Rail, Right Hand † | 1 | Refer to Page 26 |  |
| 83 | Side Rail, Left Hand †  |   |                  |  |

**Common Parts:**

|      |                                 |          |              |                 |
|------|---------------------------------|----------|--------------|-----------------|
| 101  | Pin †                           | 2        | 4308-S-1     |                 |
| 102  | Cotter Pin                      | See ( )  | 53458 (5)    | 53458 (7)       |
| 103  | Link Stud †                     | 1        | 4115         |                 |
| 104  | Brake Lever - Manual Brake †    | 1        | 4127         | ---             |
| 105  | Brake Lever - Automatic Brake † | 1        | ---          | 11349           |
| 106  | Pin                             | 2        | ---          | 8609            |
| 107  | Clevis                          | 1        | ---          | 8586            |
| 108  | Nut                             | 1        | ---          | 50152           |
| 109  | Breather                        | 1        | ---          | 52384           |
| 110  | Cylinder                        | 1        | ---          | Contact Factory |
| 111  | Fitting, Bushing                | 1        | ---          | 52006           |
| •112 | Dump Valve                      | 1        | ---          | Contact Factory |
| 113  | Fitting, Hose End               | 2        | ---          | 51029           |
| 114  | Fitting, Elbow                  | 1        | ---          | 54272           |
| 115  | Hose (bulk)                     | As Req'd | ---          | 50923-XX        |
| 116  | Capscrew                        | 3        | ---          | 52014           |
| 117  | Washer                          | See ( )  | 71293005 (4) | 71293005 (5)    |
| 118  | Bracket                         | 1        | ---          | 11329           |
| 119  | Capscrew                        | See ( )  | 71128193 (4) | 71128193 (2)    |
| 120  | Nut                             | See ( )  | 51884 (1)    | 51884 (2)       |
| 121  | Pin †                           | 3        | 4307-S       |                 |
| 122  | Pivot Bracket †                 | 1        | 10881        |                 |
| 123  | Washer                          | As Req'd | 71064851     |                 |
| 124  | Arm (27 inch Drum flange) †     | 1        | 10883        |                 |
|      | Arm (35 inch Drum flange) †     |          | 10884        |                 |
| 125  | Connecting Link †               | 1        | 10882        |                 |
| 126  | Stop Plate                      | 1        | 10879        |                 |
| 127  | Screw, Adjusting                | 1        | 71033104     |                 |
| •128 | Brake Band †                    | 1 Set    | 4103-SET     |                 |
|      | Brake Band Lining Kit           | 1 Kit    | 4103-BLK     |                 |
| 129  | Washer                          | 2        | 52914        |                 |
| 134  | Pin                             | 1        | 22442        |                 |

• Recommended spare.

XX Order in even feet increments.

† These parts also come in a cold weather version. For winches with a —C in the model code, adding CH to the end of these parts is required to retain winch certification. Example: Pivot Bracket (item 122) part number 10881 should be ordered as part number 10881CH.

# DRUM LOCKING PIN (OPTIONAL) ASSEMBLY DRAWING AND PARTS LIST

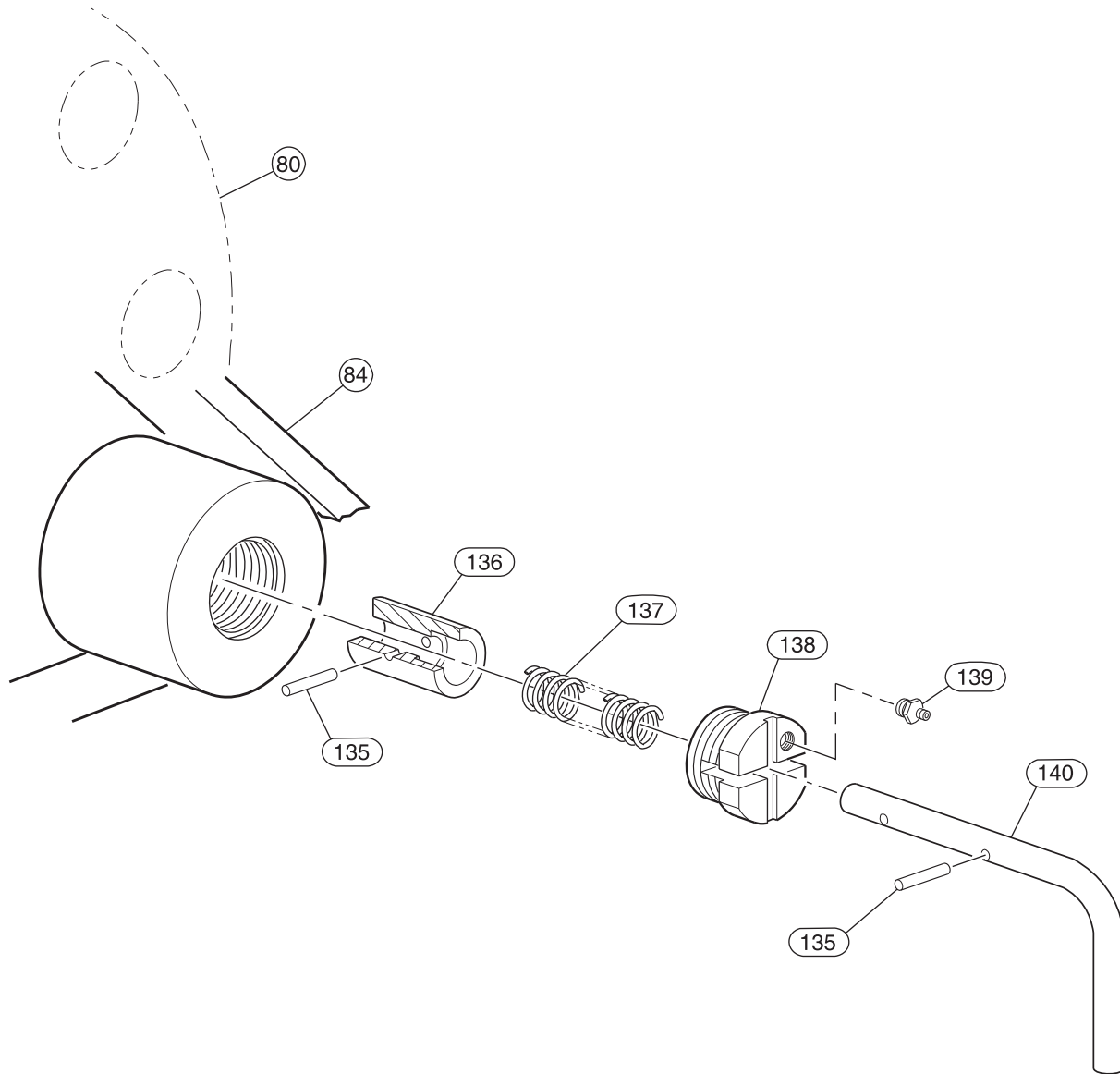

(Dwg. MHP0155)

| ITEM NO. | DESCRIPTION OF PART | QTY TOTAL | PART NUMBER | ITEM NO. | DESCRIPTION OF PART | QTY TOTAL | PART NUMBER |
|----------|---------------------|-----------|-------------|----------|---------------------|-----------|-------------|
|----------|---------------------|-----------|-------------|----------|---------------------|-----------|-------------|

**Drum:**

|    |  |   |                    |    |   |   |                    |
|----|--|---|--------------------|----|---|---|--------------------|
| 80 | with band brake †<br>(27 inch Drum flange) | 1 | Contact<br>Factory | 80 | without band brake †<br>(27 inch Drum flange) | 1 | Contact<br>Factory |
|    | with band brake †<br>(35 inch Drum flange) |   |                    |    | without band brake †<br>(35 inch Drum flange) |   |                    |

**Common Parts:**

|     |   |   |                |       |          |        |       |
|-----|---|---|----------------|-------|----------|--------|-------|
| 84  | Outboard Upright †<br>(27 inch Drum flange) | 1 | 14946          | 136   | Lock Pin | 1      | 16328 |
|     | Outboard Upright †<br>(35 inch Drum flange) |   |                | 14952 | 137      | Spring | 1     |
|     |   |   | 138            |       | Gland    | 1      | 16329 |
|     | 139   |   | Grease Fitting | 1     | 53095    |        |       |
| 135 | Pin (Zinc pt.)                              | 2 | 71001135       | 140   | Pull Rod | 1      | 16310 |

\* Contact your **Ingersoll-Rand** distributor or factory for additional replacement part information.

† These parts also come in a cold weather version. For winches with a —C in the model code, adding CH to the end of these parts is required to retain winch certification. Example: Outboard Upright (item 84) part number 14946 should be ordered as part number 14946CH.

# DRUM GUARD (OPTIONAL) ASSEMBLY DRAWING AND PARTS LIST

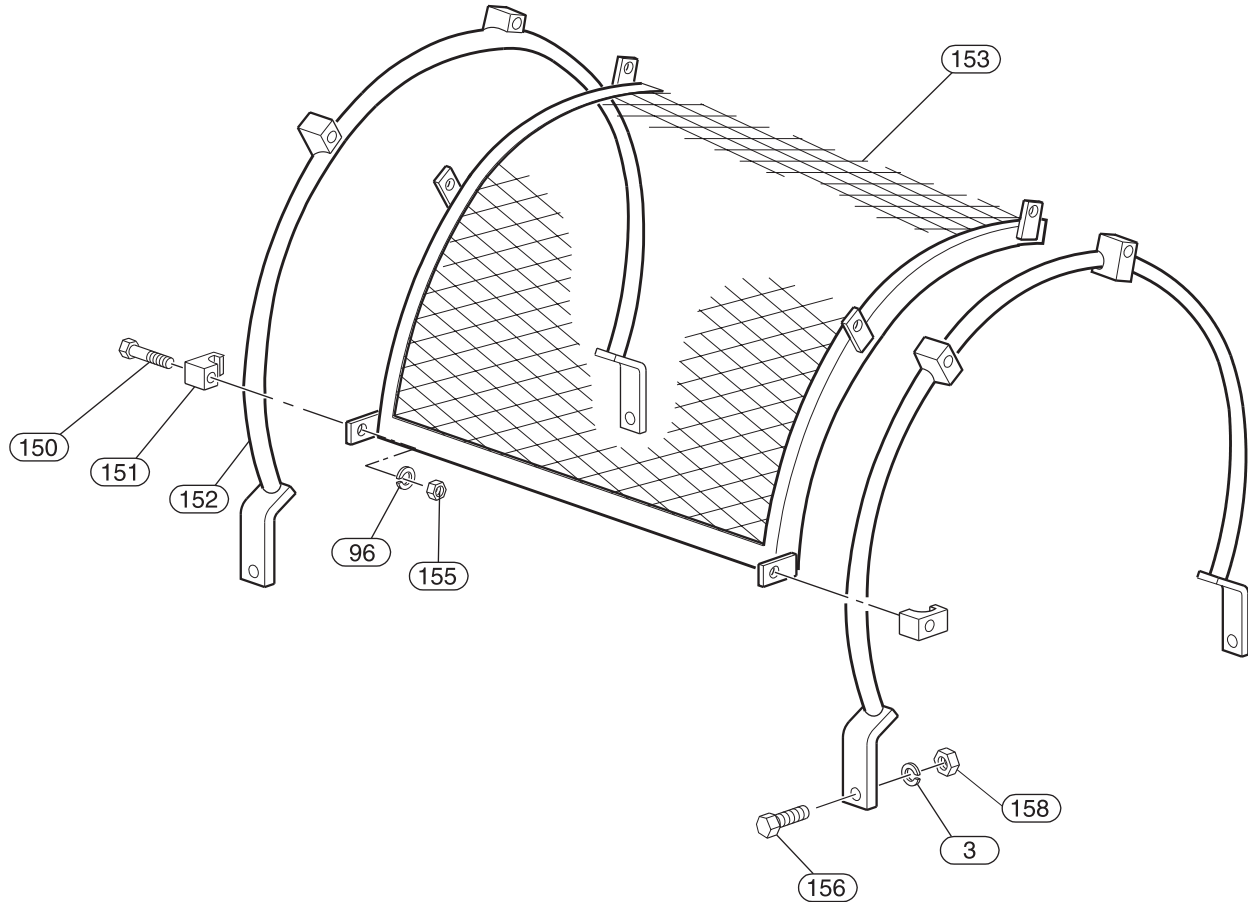

(Dwg. MHP0154)

| ITEM NO. | DESCRIPTION OF PART                     | QTY TOTAL | PART NUMBER     |             |
|----------|---|-----------|-----------------|-------------|
|          |   |           | Standard Flange | Tall Flange |
| 3        | Lockwasher                              | 4         | 50181           |             |
| 96       | Lockwasher                              | 6         | 50200           |             |
| *        | Drum Guard Assembly (12 inch long drum) | 1         | 10925-2         | 10927-2     |
|          | Drum Guard Assembly (16 inch long drum) |           | 10925-3         | 10927-3     |
|          | Drum Guard Assembly (24 inch long drum) |           | 10925-5         | 10927-5     |
|          | Drum Guard Assembly (30 inch long drum) |           | 10925-6         | 10927-6     |
|          | Drum Guard Assembly (36 inch long drum) |           | ---             | 10927-9     |
| 150      | Capscrew                                | 6         | 71126742        |             |
| 151      | Clamp                                   | 6         | 10399           |             |
| 152      | Support                                 | 2         | 10934           | 10931       |
| 153      | Drum Guard (12 inch long drum)          | 1         | 10935-2         | 10932-2     |
|          | Drum Guard (16 inch long drum)          |           | 10935-3         | 10932-3     |
|          | Drum Guard (24 inch long drum)          |           | 10935-5         | 10932-5     |
|          | Drum Guard (30 inch long drum)          |           | 10935-6         | 10932-6     |
|          | Drum Guard (36 inch long drum)          |           | ---             | 10932-8     |
| 155      | Nut                                     | 6         | 50198           |             |
| 156      | Capscrew                                | 4         | 50973           |             |
| 158      | Nut                                     | 4         | 50171           |             |

\* Assembly includes items 150 through 158.

## LABELS AND TAGS

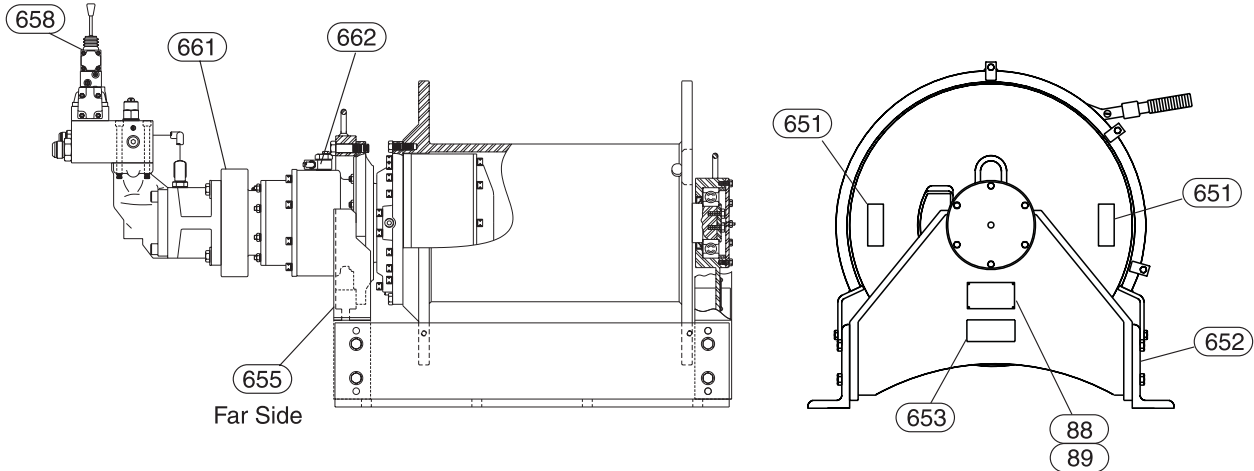

(Dwg. MHP1758)

| ITEM NO. | DESCRIPTION OF PART                                | QTY TOTAL | PART NUMBER     |
|----------|--|-----------|-----------------|
| 10       | Label and Tag Kit *                                | 1         | Contact Factory |
|          | Label and Tag Kit - CE *                           |           |                 |
| 88       | Nameplate  | 1         | 71106967-R      |
| 89       | Drive Screw  | 4         | 71028849        |
| 651      | Winding Label                                      | 1         | 71109516        |
|          | Winding Label - CE                                 |           | 96180103        |
| 652      | Ingersoll-Rand Logo Label (12-16 inch drum)        | 1         | 71106272        |
|          | Ingersoll-Rand Logo Label (24 inch or longer drum) |           | 71109102        |
| 653      | Label General - CE                                 | 1         | 71153464        |
| 654      | Product Label (12-16 inch drum)                    | 1         | 71111777        |
|          | Product Label (24 inch or longer drum)             |           | 71109508        |
| 655      | Warning Label                                      | 1         | 71060529        |
|          | Warning Label - CE                                 |           | 96180100        |
| 656      | Oil Level Label                                    | 1         | 71043616        |
| 658      | Control Valve Operation - CE                       | 1         | 96180102        |
| 661      | Warning Label (Only Non-CE)                        | 1         | 71107130        |
| 662      | Check Oil Level Label                              | 1         | 71107148        |

\* Kit part numbers ending in -4 are for drums 12-16 inches long. Numbers ending in -5 are for drums 24 inches or longer.

## ACCESSORIES

| DESCRIPTION OF ACCESSORY | ACCESSORY PART NUMBER |
|--------------------------|-----------------------|
| Lubricant                | LUBRI-LINK-GREEN      |
| Touch-up Paint (Orange)  | MHD-OR                |
| Touch-up Paint (Yellow)  | FAP-237Y              |



## PARTS ORDERING INFORMATION

The use of other than **Ingersoll-Rand** Material Handling replacement parts may result in decreased winch performance, and may, at the company's option, invalidate the warranty.

For your convenience and future reference it is recommended that the following information be recorded:

**Model Number** \_\_\_\_\_

**Serial Number** \_\_\_\_\_

**Date Purchased** \_\_\_\_\_

For prompt service and genuine **Ingersoll-Rand** Material Handling parts, provide your nearest Distributor with the following:

1. Complete model number and serial number as it appears on the nameplate.
2. Part number(s) and part description as shown in this manual.
3. Quantity required.

The nameplate is located on the winch outboard upright.

### NOTICE

- **Continuing improvement and advancement of design may produce changes to this unit which are not included in this manual. Manuals are periodically revised to incorporate changes. Always check the manual edition number on the front cover for the latest issue.**
- **Sections of this manual may not apply to your winch.**

### Return Goods Policy

**Ingersoll-Rand** will not accept any returned goods for warranty or service work unless prior arrangements have been made and written authorization has been provided from the location where the goods were purchased.

Winches that have been modified without **Ingersoll-Rand** approval, mishandled or overloaded will not be repaired or replaced under warranty. A printed copy of the warranty which applies to this winch is provided inside the back cover of this manual.

### Disposal

When the life of the unit has expired, it is recommended that the unit be disassembled, degreased and parts separated as to materials so that they may be recycled.

For additional information contact:

#### **Ingersoll-Rand Material Handling**

P.O. Box 24046  
2724 Sixth Avenue South  
Seattle, WA 98124-0046 USA  
Phone: (206) 624-0466  
Fax: (206) 624-6265

or

#### **Ingersoll-Rand Material Handling**

**Douai Operations**  
111, avenue Roger Salengro  
59450 Sin Le Noble, France  
Phone: (33) 3-27-93-08-08  
Fax: (33) 3-27-93-08-00

For additional information on this product order the publication by the referenced Part/Document Number listed:

| Publication                                | Part/Document Number | Publication           | Part/Document Number |
|--|----------------------|-----------------------|----------------------|
| Brake Lining Replacement Instruction Sheet | MHD56142             | Man-Rider® Supplement | MHD56042             |

**SERVICE NOTES**

## LIMITED WARRANTY

**Ingersoll-Rand Company (I-R)** warrants to the original user its Products to be free of defects in material and workmanship for a period of one year from the date of purchase. **I-R** will repair, without cost, any Product found to be defective, including parts and labor charges, or at its option, will replace such Products or refund the purchase price less a reasonable allowance for depreciation, in exchange for the Product. Repairs or replacements are warranted for the remainder of the original warranty period.

If any Product proves defective within its original one year warranty period, it should be returned to any Authorized Hoist and Winch Service Distributor, transportation prepaid with proof of purchase or warranty card.

This warranty does not apply to Products which **I-R** has determined to have been misused or abused, improperly maintained by the user, or where the malfunction or defect can be attributed to the use of non-genuine **I-R** parts.

**I-R makes no other warranty, and all implied warranties including any warranty of merchantability or fitness for a particular purpose are limited to the duration of the expressed warranty period as set forth above. I-R's maximum liability is limited to the purchase price of the Product and in no event shall I-R be liable for any consequential, indirect, incidental, or special damages of any nature rising from the sale or use of the Product, whether based on contract, tort, or otherwise.**

Note: Some states do not allow limitations on incidental or consequential damages or how long an implied warranty lasts so that the above limitations may not apply to you.

This warranty gives you specific legal rights and you may also have other rights which may vary from state to state.

## IMPORTANT NOTICE

It is our policy to promote safe delivery of all orders. This shipment has been thoroughly checked, packed and inspected before leaving our plant and receipt for it in good condition has been received from the carrier. Any loss or damage which occurs to this shipment while en route is not due to any action or conduct of the manufacturer.

### **Visible Loss or Damage**

If any of the goods called for on the bill of lading or express receipt are damaged or the quantity is short, do not accept them until the freight or express agent makes an appropriate notation on your freight bill or express receipt.

### **Concealed Loss or Damage**

When a shipment has been delivered to you in apparent good condition, but upon opening the crate or container, loss or damage has taken place while in transit, notify the carrier's agent immediately.

### **Damage Claims**

You must file claims for damage with the carrier. It is the transportation company's responsibility to reimburse you for repair or replacement of goods damaged in shipment. Claims for loss or damage in shipment must not be deducted from the **Ingersoll-Rand** invoice, nor should payment of **Ingersoll-Rand** invoice be withheld awaiting adjustment of such claims as the carrier guarantees safe delivery.

You may return products damaged in shipment to us for repair, which services will be for your account and form your basis for claim against the carrier.

## United States Office Locations

### For Order Entry and Order Status

**Ingersoll-Rand  
Distribution Center**  
P.O. Box 618  
510 Hester Drive  
White House, TN 37188  
Phone: (615) 672-0321  
Fax: (615) 672-0801

### Technical Support

**Ingersoll-Rand  
Material Handling**  
P.O. Box 24046  
2724 Sixth Avenue South  
Seattle, WA 98124-0046 USA  
Phone: (206) 624-0466  
Fax: (206) 624-6265

**Web Site:**  
[www.ingersoll-rand.com](http://www.ingersoll-rand.com)

### Regional Sales Offices

**Chicago, IL**  
888 Industrial Drive  
Elmhurst, IL 60126  
Phone: (630) 530-3800  
Fax: (630) 530-3891

**Detroit, MI**  
23192 Commerce Drive  
Farmington Hills, MI 48335  
Phone: (248) 476-6677  
Fax: (248) 476-6670

**Houston, TX**  
450 Gears Road  
Suite 210  
Houston, TX 77067-4516  
Phone: (281) 872-6800  
Fax: (281) 872-6807

**Los Angeles, CA**  
11909 E. Telegraph Road  
Santa Fe Springs, CA  
90670-0525  
Phone: (562) 948-4189  
Fax: (562) 948-1828

**Philadelphia, PA**  
P.O. Box 425  
900 E. 8th Ave., Suite 103  
King of Prussia, PA 19406  
Phone: (610) 337-5930  
Fax: (610) 337-5912

## International Office Locations

Offices and distributors in principal cities throughout the world. Contact the nearest **Ingersoll-Rand** office for the name and address of the distributor in your country or write/fax to:

**Ingersoll-Rand  
Material Handling**  
P.O. Box 24046  
2724 Sixth Avenue South  
Seattle, WA 98124-0046 USA  
Phone: (206) 624-0466  
Fax: (206) 624-6265

**Canada  
National Sales Office  
Regional Warehouse  
Toronto, Ontario**  
51 Worcester Road  
Rexdale, Ontario  
M9W 4K2  
Phone: (416) 213-4500  
Fax: (416) 213-4510  
**Order Desk**  
Fax: (416) 213-4506

**Regional Sales Offices  
Edmonton, Alberta**  
1430 Weber Center  
5555 Calgary Trail N.W.  
Edmonton, Alberta  
T6H 2P9  
Phone: (403) 438-5039  
Fax: (403) 437-3145

**Montreal, Quebec**  
3501 St. Charles Blvd.  
Kirkland, Quebec  
H9H 4S3  
Phone: (514) 695-9040  
Fax: (514) 695-0963

**British Columbia**  
1200 Cliveden Avenue  
Delta, B. C.  
V3M 6G4  
Phone: (604) 523-0803  
Fax: (604) 523-0801

**Latin America Operations  
Ingersoll-Rand  
Production Equipment Group**  
730 N.W. 107 Avenue  
Suite 300, Miami, FL, USA  
33172-3107  
Phone: (305) 559-0500  
Fax: (305) 222-0864

**Europe, Middle East and  
Africa  
Ingersoll-Rand  
Material Handling  
Douai Operations**  
111, avenue Roger Salengro  
59450 Sin Le Noble, France  
Phone: (33) 3-27-93-08-08  
Fax: (33) 3-27-93-08-00

**Asia Pacific Operations  
Ingersoll-Rand Asia Pacific Inc.**  
Suite 1201-3, 12/F  
Central Plaza  
18 Harbour Road  
Wanchai, Hong Kong  
Phone: (852) 9794 1673  
Fax: (852) 9794 7895

**Russia  
Ingersoll-Rand**  
Kuznetsky Most 21/5  
Entrance 3  
Moscow 103895 Russia  
Phone: 7-501-923-91-34  
Fax: 7-501-924-46-25