

PARTS, INSTALLATION AND MAINTENANCE MANUAL for LIGHT DUTY TOOL ARM

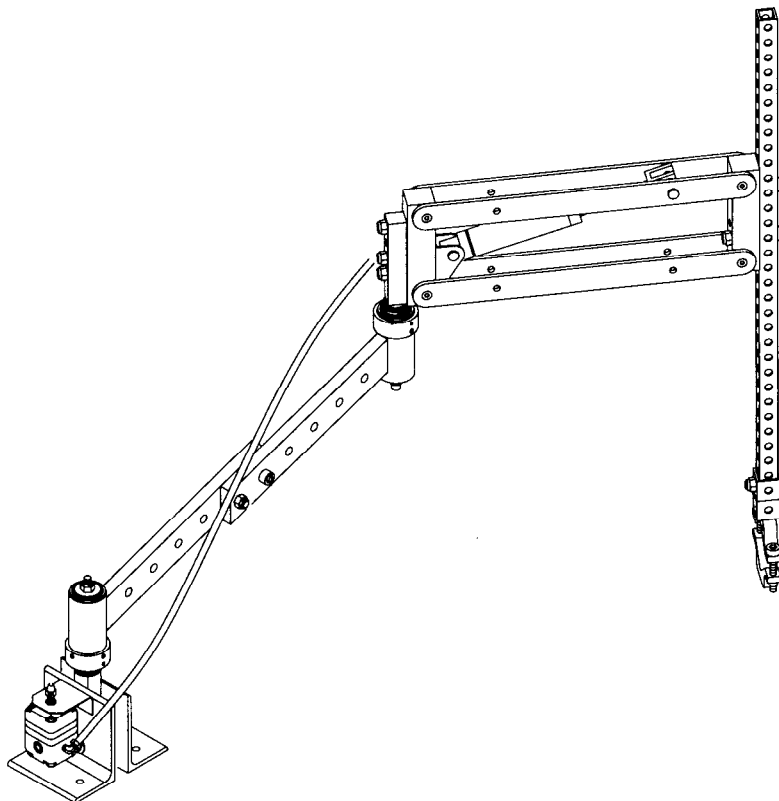

(Dwg. MHP1766)

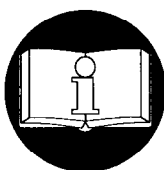

READ THIS MANUAL BEFORE USING THESE PRODUCTS. This manual contains important safety, installation and maintenance information. Make this manual available to all persons responsible for the operation, installation and maintenance of these products.

⚠ WARNING

This equipment is intended for industrial use only and must not be used for lifting or supporting loads over people.

Always operate, inspect and maintain this tool arm system in accordance with applicable safety codes and regulations.

Refer all communications to the nearest Ingersoll-Rand Material Handling Office or Distributor.

TABLE OF CONTENTS

Description	Page No.
Safety Information	
Danger, Warning, Caution and Notice.....	3
Safety Summary.....	3
Safe Operating Instructions	4
Mounting Configurations	4
Specifications	
Description.....	5
Installation	
Mounting the Unit.....	5
Air System	7
Adjustments	8
Operation	
Description of Operation	9
Principles of Operation	9
Inspection	
Records and Reports	10
Frequent Inspection.....	10
Periodic Inspection	10
Inspection and Maintenance Report	11
Troubleshooting	12
Maintenance	
Maintenance Intervals.....	13
Adjustments	13
General Maintenance	13
Air Cylinder Replacement	14
Pivot Bearing Replacement	14
Cleaning, Inspection and Repair.....	14
Testing	14
Parts Ordering Information	
Returned Goods Policy	15
Parts List	17
Options, Attachments and Accessories	18
Warranty	19

SAFETY INFORMATION

This manual provides important information for all personnel involved with the safe installation, operation and proper maintenance of this product. Even if you feel you are familiar with this or similar equipment, you should read this manual before operating the product.

Danger, Warning, Caution and Notice

Throughout this manual there are steps and procedures which, if not followed, may result in an injury. The following signal words are used to identify the level of potential hazard.

DANGER

Danger is used to indicate the presence of a hazard which **will** cause **severe** injury, death or substantial property damage if the warning is ignored.

WARNING

Warning is used to indicate the presence of a hazard which **can** cause **severe** injury, death or substantial property damage if the warning is ignored.

CAUTION

Caution is used to indicate the presence of a hazard which **will** or **can** cause injury or property damage if the warning is ignored.

NOTICE

Notice is used to notify people of installation, operation or maintenance information which is important but not hazard-related.

Safety Summary

Personal protective and safety equipment must be used and maintained in accordance with the manufacturer's instructions. The Tool Arm should not be left suspended when not in use. Lower the tool to the floor or a suitable location.

WARNING

- **Do not use this unit or attached equipment for lifting or supporting loads over people.**
- **The supporting structures and load-attaching devices used in conjunction with these units must provide a safety factor of at least three times the rated capacity of the unit. This is the customer's responsibility. If in doubt, consult a registered structural engineer.**
- **If system air pressure is lost, lower the arm immediately. Operators must stay out of the vertical path of the arm.**

NOTICE

- **Lifting equipment is subject to different regulations in each country. These regulations may not be specified in this manual.**

Employees who work near suspended loads or operate tool arm should be instructed to keep out from under the tool and arm. From a safety standpoint, one factor is paramount: conduct all operations in such a manner that if there were an equipment failure, no personnel would be injured. This means keep out from under a raised tool and keep out of the intended path of that tool.

It is the owner's and user's responsibility to determine the suitability of a product for any particular use. It is recommended that all applicable industry, trade association, federal, state and local regulations be checked. Read all operating instructions and warnings before operation.

This manual has been produced by **Ingersoll-Rand** to provide dealers, mechanics, operators and company personnel with information required to install, operate, maintain and repair products described herein.

It is extremely important that mechanics and operators be familiar with the servicing procedures of these products, or like or similar products, and are physically capable of conducting the procedures. These personnel shall have a general working knowledge that includes:

1. Proper and safe use and application of mechanic's common hand tools as well as special **Ingersoll-Rand** or recommended tools.
2. Safety procedures, precautions and work habits established by accepted industry standards.

Ingersoll-Rand cannot know of, or provide, all the procedures by which product operations or repairs may be conducted and the hazards and/or results of each method. If operation or maintenance procedures not specifically recommended by the manufacturer are conducted, it must be ensured that product safety is not endangered by the actions taken. If unsure of an operation or maintenance procedure or step, personnel should place the product in a safe condition and contact supervisors and/or the factory for technical assistance.

SAFE OPERATING INSTRUCTIONS

The following warnings and operating instructions are intended to avoid unsafe operating practices which might lead to injury or property damage.

Ingersoll-Rand recognizes that most companies using this type of equipment have a safety program in force at their facility. If you are aware that some conflict exists between a rule set forth in this publication and a similar rule already set by an individual company, the more stringent of the two should take precedence.

This manual supports a fully installed system. Operators should be familiar with the operation of the unit before use.

Safe Operating Instructions are provided to make an operator aware of dangerous practices to avoid and are not necessarily limited to the following list. Refer to specific sections in the manual for additional safety information.

1. Only allow personnel trained in safety and operation of this product to operate and maintain the unit.
2. Only operate unit if you are physically fit to do so.
3. When a **"DO NOT OPERATE"** sign is placed on the system, do not operate the unit until the sign has been removed by designated personnel.
4. Before each shift, check unit for wear and damage. Never use a unit that inspection indicates is worn or damaged.
5. Never exceed tool capacity of the unit.
6. Be certain tool holder and tool extension are properly secured.
7. Pay attention to tool at all times when operating unit.
8. Make sure everyone is clear of Tool Arm path. Do not lift over people.
9. Never weld or cut on components connected to unit.
10. Shut off air supply before performing any maintenance.
11. Use good posture when operating system.
12. Check air connections for leakage.

MOUNTING CONFIGURATIONS

Table Mount Extension Up

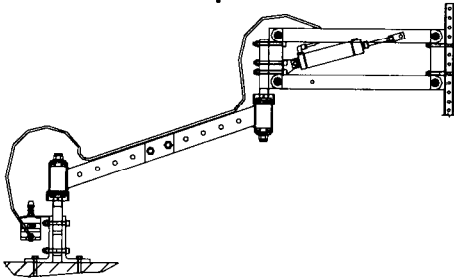

Overhead Mount Extension Down

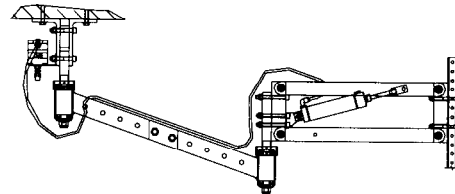
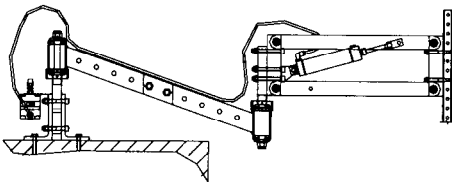
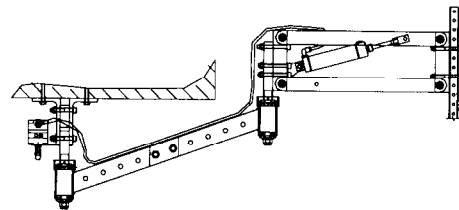

Table Mount Extension Down



Overhead Mount Extension Up



Wall Mount Extension Up

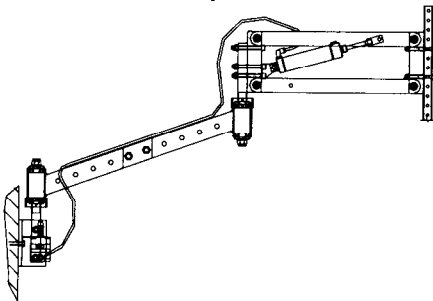

Fixed Machine Mount

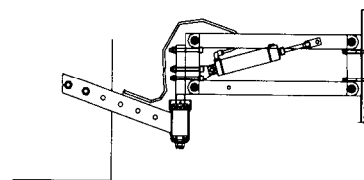

(Dwg. MHP1767)

SPECIFICATIONS

Description

The Tool Arm is pre-assembled at the factory for ease of installation. The arm will automatically raise up and retract away to the operator's right. Refer to Dwg. MHP1767 on page 4 for various installation options and configurations.

Tool Arm

Weight	Contact Factory
Maximum Tool Weight	14.96 kg (33 lb)
Maximum Torque Reaction	80 Nm (60 ft-lb)
Material	Anodized Aluminum

Tool Holder

Minimum Tool Diameter	Maximum Tool Diameter
12.7 mm (0.5 in.)	63.5 mm (2.5 in.)

Technical Data

Pressure	Lift Capacity	Torque Capacity	Maximum Vertical Travel
kPa (psi)	kg (lb)	Nm (ft-lb)	mm (in)
698 (100)	13.6 (30.0)	81.0 (60.0)	508 (20.0)
620 (90)	11.8 (26.0)		
551 (80)	10.4 (23.0)		
482 (70)	9.0 (20.0)		
413 (60)	6.8 (15.0)		

INSTALLATION

Prior to installing unit, carefully inspect it for possible shipping damage.

⚠ CAUTION

- Owners and users are advised to examine specific, local or other regulations, including American National Standards Institute and/or OSHA Regulations which may apply to a particular use of this product before installing or putting unit to use.
- Before installing Tool Arm system read "SAFETY INFORMATION" section on page 3.

Ensure unit is properly installed. A little extra time and effort in doing so can contribute a lot toward preventing accidents or injuries and will help achieve the best service possible.

NOTICE

- Lubrication of the Tool Arm is not recommended.

Torque Specification Table

Metric Bolt Size	Class 10.9 Tightening Torque					
	Dry		Lubricated		Teflon-coated	
	Nm	ft-lb	Nm	ft-lb	Nm	ft-lb
M8 x 1.25	35-41	26-30	27-30	20-22	16-18	12-13
M10 x 1.5	72-81	53-60	53-61	39-45	33-37	24-27
M12 x 1.75	123-140	91-103	92-105	68-77	56-63	41-46

Ensure mounting structure and hardware provide adequate support to handle all anticipated loads. The Tool Arm must be capable of moving within its designated range without interfering with surrounding equipment and allow safe traffic flow of personnel and equipment in the area.

Mounting the Unit

Ensure the supporting member to which the Tool Arm is attached is strong enough to support the weight of the unit plus the weight of any attached optional components and a maximum rated load, plus a generous factor of at least 300% of the combined weights. If in doubt, contact a registered structural engineer.

Ensure the installation area provides adequate room to safely operate the Tool Arm and attached components throughout the complete range of motion.

The Tool Arm may be mounted to a stationary foundation, beam or vertical structure. Consult a registered structural engineer to determine a suitable installation configuration. Use angle brackets, as necessary, to mount the arm to a ceiling, column, machine or work surface.

Ensure the Tool Arm is mounted to provide operators with the most ergonomically efficient operating range.

Use 10 mm (3/8 in.) grade 5 or better bolts (4 each required). Tighten bolts to recommended torque.

Angled mounting brackets (30) can be attached to the mounting shaft (16) in two different positions. Assemble mounting brackets to suit desired mounting position. Refer to Dwg. MHP1769, Dwg. MHP1768 and Dwg. MHP1776 on page 6 and Dwg. MHP1754 on page 16.

Vertical Surface Mount (Wall Mount)

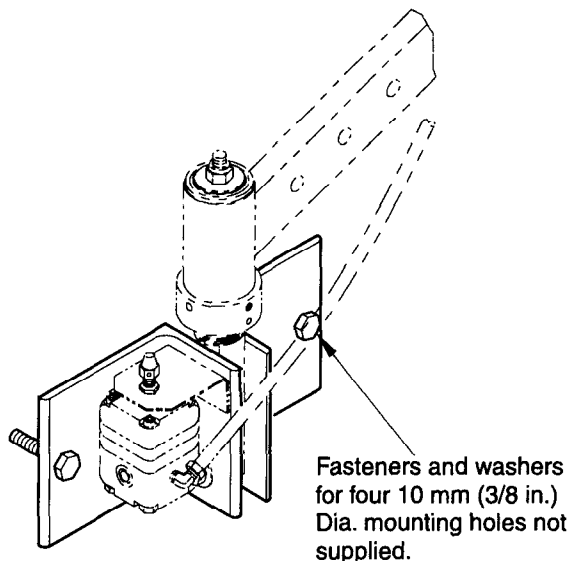

(Dwg. MHP1769)

Horizontal Surface Mount (Table/Floor Mount)

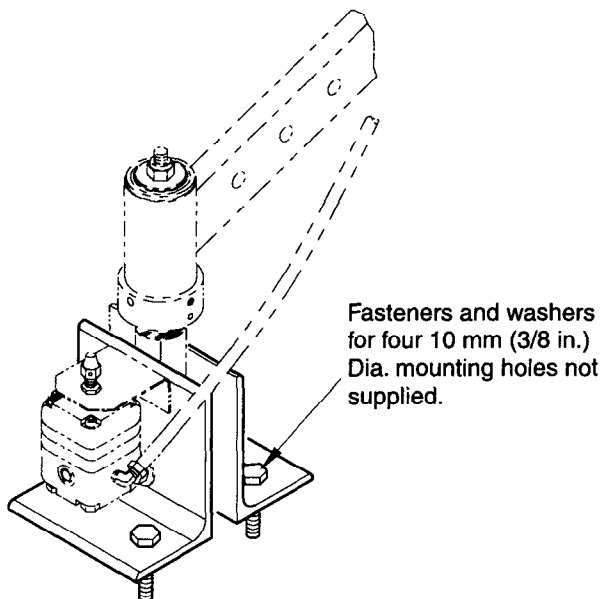

(Dwg. MHP1768)

Attaching the Tool Holder

Refer to Dwg. MHP1754 on page 16. Attach the tool holder to the extension arm (8) using capscrew (40) and locknut (6).

Install tool in tool holder and tighten capscrews to clamp tool into position.

Extension Arm Installation

Refer to Dwg. MHP1772 on page 7.

1. Align extension arm (8) to allow full range of motion for the application.
2. Install capscrew (5) through extension arm (8) and adapter block (4).
3. Install locknuts (6) and tighten to specified torque.

Horizontal Surface Mount (Ceiling Mount)

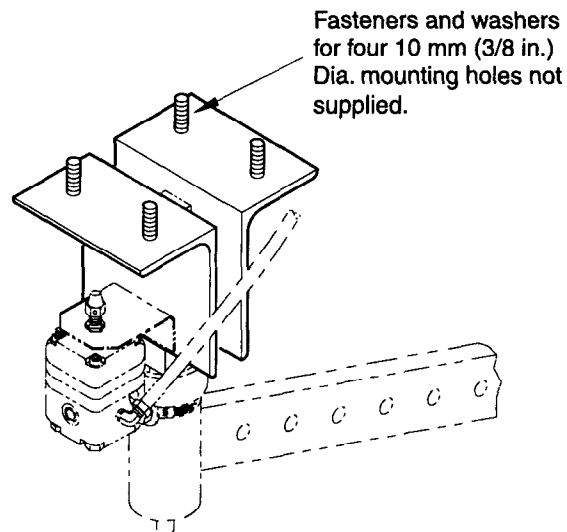

(Dwg. MHP1776)

Tool Arm Installation

Refer to Dwg. MHP1772 on page 7.

1. Install tool holder (41) to bottom of extension arm (8).
2. Install capscrew (40) through extension arm (8) and tool holder (41).
3. Install locknut (6) and tighten to specified torque.
4. Install torque tool in tool holder (41).
5. Install tool clamp (43).
6. Install bolts (42) and tighten to specified torque.

Spring Retract Modification

Refer to Dwg. MHP1771 on page 8.

This task changes the retract direction of the arm.

1. Remove upper arm from lower arm. Refer to the "MAINTENANCE" section on page 13 for directions.
2. Remove the spring adjustment collar (20) and spring (17) from the upper pivot assembly.
3. Remove lower arm from base. Refer to "MAINTENANCE" section on page 13 for directions.
4. Remove the spring adjustment collar (20) and spring (27) from the lower pivot assembly.
5. Install spring (17) on the lower pivot assembly.
6. Install spring (27) on the upper pivot assembly.
7. This will reverse the retract direction of the arm.
8. Install spring adjustment collar (20) on the upper pivot assembly. Do not tighten setscrews.
9. Install upper arm assembly to the lower arm pivot mount.
10. Install locknut (24) and washer (23). Tighten locknut to specified torque.
11. Install spring adjustment collar (20) on the lower pivot assembly. Do not tighten setscrews (21).
12. Install tool arm assembly to the base.
13. Install locknut (24) and washer (23). Tighten nut to specified torque.
14. Follow 'Spring Retract Adjustment' procedures.

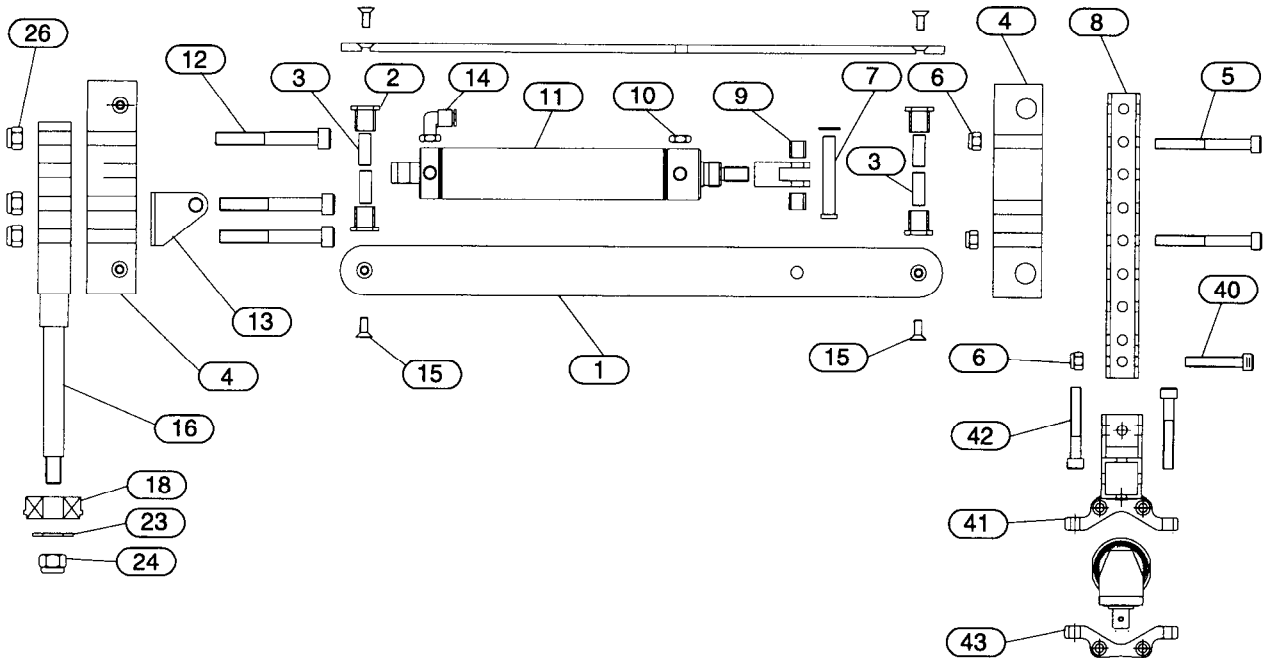

(Dwg. MHP1772)

Regulator Installation

Refer to Dwg. MHP1774 on page 7.
 The regulator is connected with a connector fitting (50) and a check valve (56). The connector fitting (50) should be threaded into the regulator output port. The check valve (56) will be threaded into the regulator input port.

NOTICE

• The arrow on the check valve (56) must be pointing toward the cylinder. If the check valve is installed backwards, the cylinder will not function.

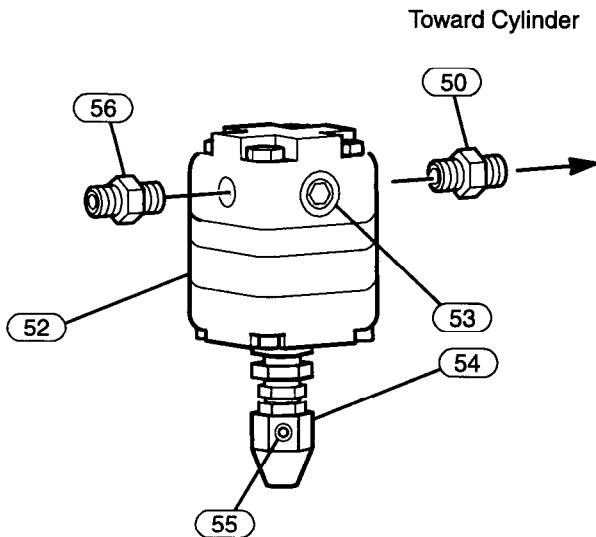

(Dwg. MHP1774)

Regulator Parts List

Item No.	Description of Part	Qty. Total	Part Number
31	Regulator Assembly (Incl's items 50 through 56)	1	13825
50	Fitting, Connector	1	13840
52	Regulator	1	13830
53	Plug	2	10764
54	Control Knob	1	13832
55	Setscrew	1	13833
56	Check Valve	1	13270

Attaching Air Cylinder

Refer to Dwg. MHP1754 on page 16.
 Tool Arms are supplied with the cylinder installed. If it is necessary to install a cylinder, position cylinder (11) between parallel links (1) and align rod end and cylinder end hole with locating pin holes in the bracket (13) and pin holes in parallel links. Install pins and secure in location with retainers.

Air System

An air supply system is required for the Tool Arms. The air supply is connected to the cylinder and may be used for tool operation.

The supply air must be clean and free from water and water vapor. 6.9 bar/690 kPa (100 psig) at the regulator is required to provide rated capacity. Do not exceed 6.9 bar/690 kPa (100 psig).

WARNING

• Do not use an air line lubricant of any kind. Oil may damage internal components.

Check the tool manufacturer's specifications for correct air supply requirements.

Air Lines

The inside diameter of the air supply lines should not be smaller than 6 mm (1/4 in.), based on a maximum of 30 m (100 ft.) between the air supply and the unit. Contact the factory for recommended air line sizes for distances greater than 30 m (100 ft.).

Before making final connections, all air supply lines should be purged. Supply lines should be as short and straight as installation conditions will permit. Long transmission lines and excessive use of fittings, elbows, tees, globe valves, etc. will cause a reduction in pressure due to restrictions and surface friction in the lines. If quick-disconnect fittings are used at the inlet of the unit, they must have at least a 6 mm (1/4 in.) air passage. Use of smaller fittings may affect performance.

Air Line Filter

It is recommended that a filter/regulator package be used. Refer to the "OPTIONS, ATTACHMENTS AND ACCESSORIES" section.

The air line strainer/filter should be installed as close as practical to the Tool Arm air inlet port. The strainer/filter should provide 5 micron filtration and include a moisture trap. Clean the strainer/filter monthly to maintain its operating efficiency.

To maintain dry air, the frequency for draining the filter should also be based on the condition of the air supply. It is recommended that the filter be drained weekly at first. Depending on air supply condition, a proper filter drain schedule should be established.

Moisture in Air Lines

Moisture that reaches the Tool Arm and associated components through the supply lines is the chief factor in determining the length of time between service overhauls. Moisture traps can help to eliminate moisture. Other methods, such as an air receiver that collects moisture before it reaches the unit, or an aftercooler at the compressor that cools air prior to distribution through the supply lines, are also helpful.

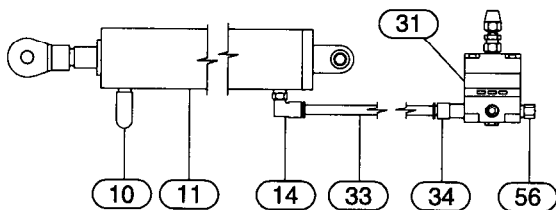

(Dwg. MHP1775)

Air System Parts List

Item No.	Description of Part	Qty. Total	Part Number
10	Breather	1	93884
11	Cylinder	1	55603
14	Fitting, Elbow	1	93971
31	BA Regulator	1	13830
33	Tube	1	93961-B
34	Fitting, Tube Connector	1	93972
56	Check Valve	1	13270

Adjustments

Prior to operating the Tool Arm System, but after installation, ensure the following adjustments are made as they apply to your assembly and optional components.

1. If necessary, adjust air regulator as described in this section. Refer to 'Regulator Installation' on page 7 and 'Operational Adjustments' on page 9.
2. Adjust Spring Retracts to suit application requirements.

Spring Retract Adjustment

Refer to Dwg. MHP1771 on page 8.

NOTICE

• The following instructions apply to the arm in the retract to the operator's right configuration. If this has been altered, the adjustments will be the opposite.

1. Loosen spring adjustment collar setscrew(s) (21).
2. Rotate the spring adjustment collar (20) at the lower pivot clockwise to increase the tension on the spring and increase the retract speed of the lower arm.
3. Rotate the spring adjustment collar at the upper pivot counterclockwise to increase the retract speed of the upper arm.
4. Tighten spring adjustment collar setscrew(s) (21).

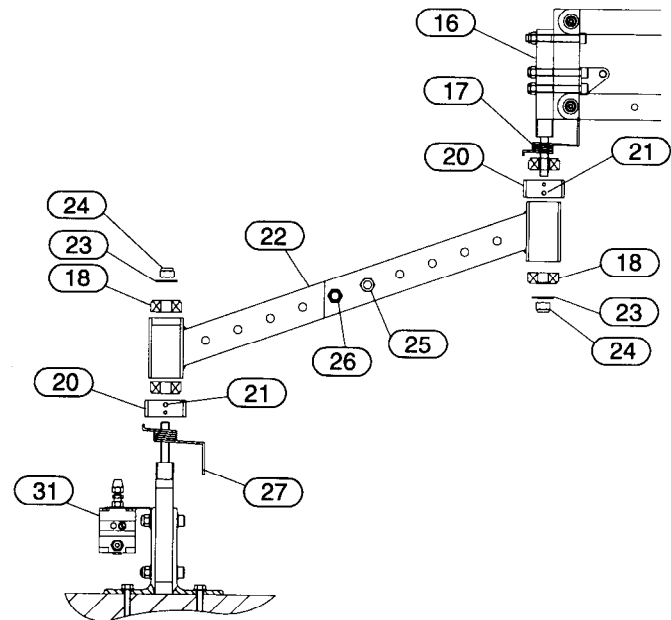

(Dwg. MHP1771)

Operational Adjustments

To establish a “zero gravity” condition for the operator to manipulate the tool, complete the following adjustment procedures:



• **Prior to performing operational adjustments or servicing, ensure air supply is off and unit is not under load.**

1. Turn adjustment knob (54) counterclockwise until unit stops.
2. Attach tool to unit. This will require that the tool be installed in the tool holder. Connect coiled air tube.
3. Turn on air supply.
4. Turn the adjustment knob clockwise until the load begins to move. The regulator is properly set when equal effort is required to raise and lower the load.
5. Tighten the locknut on the regulator stem to lock the adjustment in position.

Lower Pivot Arm Adjustment

Refer to Dwg. MHP1771 on page 8.

1. The lower pivot arm is assembled to its shortest length, 368 mm (14.5 in.) (approximately), and is adjustable up to 559 mm (22 in.).
2. Remove arm from base and place on a sturdy work surface, or support the upper section of the arm. Refer to ‘Spring Retract Modification’ for arm removal.
3. Remove locknut (26) from capscrew (25) in two places from lower arm.
4. Adjust the length of the lower arm to the required dimension.
5. Align lower arm bolt holes so both capscrews can be installed.
6. Install capscrew (25) and locknut (26) in two places on the arm.

OPERATION

The four most important aspects of the tool arm operation are:

1. Follow all safety instructions when operating the unit.
2. Allow only people trained in safety and operation of this product to operate the unit.
3. Subject each unit to a regular inspection and maintenance procedure.
4. Be aware of the unit capacity and operating range at all times.

Ensure operators use suitable personal protective equipment when operating Tool Arm and attached tools. Maintain personal protective equipment in accordance with manufacturer’s instructions.

At the end of each shift, or prior to turning off the air supply, lower tool to its lowest position.

Description of Operation

The Tool Arm is an integrated group of components designed to maximize the interaction of man and machine. Ease of operation minimizes operator fatigue and incorporates added safety during the performance of repetitive tasks.

Principles of Operation

The Tool Arm is designed to allow vertical and/or horizontal operational control within a specific range of motion. During travel ensure tool travel path is clear and pay attention to the direction of travel during movement.

Vertical raising and lowering of the tool should be easily accomplished by exerting force on the tool. Use the tool to move side to side and to raise or lower the Tool Arm.

Tool Holder (optional feature)

Two Tool Holder designs are available.

Fixed Horizontal/Vertical (Two Axis):

To reposition tool either loosen tool clamp capscrews to rotate tool in tool holder or remove capscrew and nut to reposition tool holder on arm extension. Tighten capscrews when correct adjustment is obtained.

360° Tool Holder (Three Axis):

To rotate a tool held in tool holder, pull out plunger and rotate to desired position. Allow plunger to spring-return to locked position. Rotate tool slightly to engage the locking pin.

⚠ WARNING

- All new, altered or modified equipment should be inspected and tested by personnel instructed in safety, operation and maintenance of this equipment to ensure safe operation at rated specifications before placing equipment in service.
- Never use a unit that inspection indicates is damaged.

Inspection intervals recommended in this manual are based on intermittent operation of the equipment eight hours each day, five days per week, in an environment relatively free of dust, moisture and corrosive fumes. If the equipment is operated almost continuously or more than the eight hours each day, more frequent inspections will be required.

Frequent and periodic inspections should be performed on equipment in regular service. Frequent inspections are visual examinations performed by operators or personnel trained in safety and operation of this equipment and include observations made during routine equipment operation. Periodic inspections are thorough inspections conducted by personnel trained in the safety, operation and maintenance of this equipment. Inspection intervals depend upon the nature of the critical components of the equipment and the severity of usage.

Careful inspection on a regular basis will reveal potentially dangerous conditions while still in the early stages, allowing corrective action to be taken before the condition becomes dangerous.

Deficiencies revealed through inspection, or noted during operation, must be reported to designated personnel instructed in safety, operation and maintenance of this equipment. A determination as to whether a condition constitutes a safety hazard must be made, and the correction of noted safety hazards accomplished and documented by written report before placing the equipment in service.

Records and Reports

Inspection records, listing all points requiring periodic inspection, should be maintained for all load bearing equipment. Written reports, based on severity of service, should be made on the condition of critical parts as a method of documenting periodic inspections. These reports should be dated, signed by the person who performed the inspection and kept on file where they are readily available for review.

Frequent Inspection

For equipment in continuous service, frequent inspections should be made by operators at the beginning of each shift.

1. OPERATION. Check for visual signs or abnormal movement that could indicate a potential problem. Ensure Tool Arm and tool movement is smooth and unrestricted.
2. FASTENERS. Ensure fasteners are secure. Tighten loose and replace damaged fasteners.
3. TOOL HOLDER (optional feature). Ensure tool holder clamps are not damaged. On 360° Tool Holders, ensure tool holder rotates freely and locking mechanism provides positive stop.
4. AIR SYSTEM. Visually inspect all connections, fittings, hoses and components for indication of air leaks. Repair any leaks or damage and tighten any loose connections.

Periodic Inspection

Frequency of periodic inspection depends on the severity of usage:

NORMAL	HEAVY	SEVERE
yearly	semiannually	quarterly

Disassembly may be required for HEAVY or SEVERE usage. Keep cumulative written records of periodic inspections to provide a basis for continuing evaluation.

Inspect all items listed in 'Frequent Inspection'. Also inspect the following:

1. FASTENERS. Verify fasteners are tight. Torque fasteners to recommended torque levels.
2. AIR CYLINDER. Ensure cylinder vent is clean and unrestricted. Check cylinder for leaks and external damage. Replace or repair cylinder as required.
3. TOOL EXTENSION ARM. Check for wear and damage. Ensure arm is not bent. Repair or replace as necessary.
4. PIVOT ASSEMBLY. Ensure Tool Arm pivots freely and limit stops are correctly adjusted. Refer to "INSTALLATION" section for adjustment information.

INSPECTION AND MAINTENANCE REPORT

Ingersoll-Rand Tool Arm

Model Number:		Date:	
		Inspected by:	
Reason for Inspection: (Check Applicable Box)		Operating Environment: Normal _____ Heavy _____ Severe _____	
	1. Scheduled Periodic Inspection: ____ Quarterly ____ Semiannually ____ Yearly		
	2. Discrepancies noted during Frequent Inspections.		
	3. Discrepancies noted during Maintenance.		
	4. Other: _____		

Refer to the Parts, Operation and Maintenance Manual "INSPECTION" section for general inspection criteria. Also, refer to appropriate National Standards and codes of practice. If in doubt about an existing condition, contact the nearest **Ingersoll-Rand** Distributor or the factory for technical assistance.

COMPONENT	CONDITION		CORRECTIVE ACTION		NOTES
	Pass	Fail	Repair	Replace	
Parallel Links					
Fasteners			---		
Bearings			---		
Pivot Pins			---		
Tool Extension					
Supporting Structure					
Bushings			---		
Labels and Tags			---		
Air Cylinder					
Tool Holder					
Air System					
Other Components (list in NOTES section)					

This page may be photocopied and used as an Inspection/Maintenance record.

TROUBLESHOOTING

This section provides basic troubleshooting information. Determination of specific causes to problems are best identified by thorough inspections performed by personnel instructed in safety, operation and maintenance of this equipment. The chart below provides a brief guide to possible problems and remedies.

COMPONENT	SYMPTOM	REMEDY
Pivot Assemblies	Movement is not smooth, or may be binding.	Inspect pivot assembly. Repair or replace as necessary to ensure pivot assembly movement is smooth and does not bind. Check spring retract adjustment.
	Fasteners are loose.	Ensure fasteners are tightened to rated torque specifications.
	Lack of lubrication in pivot assembly.	Lubricate pivot assembly.
Control Hoses	Hose leaks at fittings or along length of hose.	Replace worn, leaking or damaged hoses and fittings.
	Hose binding at connections.	Ensure swivel connections operate correctly without sticking or binding. Replace fittings that stick or bind.
Cylinder	Effort to extend or retract Tool Arm is not equal.	Check regulator adjustment.
		Ensure cylinder vent is clean and unrestricted.
Parallel Links	Movement up and down is restricted.	Inspect flanged bushings. Replace flanged bushings if worn or damaged.

MAINTENANCE

⚠ CAUTION

- Use of replacement parts other than genuine Ingersoll-Rand parts could result in damage to the unit and void the warranty.

⚠ WARNING

- Never perform maintenance on the Tool Arm while it is supporting a tool.

- Before performing maintenance, tag arm:

**DANGER – DO NOT OPERATE –
EQUIPMENT BEING REPAIRED**

- Only allow service personnel trained in safety and maintenance on this unit to perform maintenance.
- After performing any maintenance on the unit, adjust and test unit in specified application before returning to service.
- Shut off air system and depressurize air lines before performing any maintenance.

Maintenance Intervals

The Maintenance Interval Chart below is based on intermittent operation of the unit for eight hours each day, five days per week. If unit operation exceeds eight hours per day, or use is under HEAVY or SEVERE conditions, more frequent maintenance should be performed. Refer to Periodic Inspection in the "INSPECTION" section for interval guidance.

INTERVAL	MAINTENANCE CHECK
Start of each shift (Operator or Maintenance Personnel)	Make a thorough visual inspection of the Tool Arm and attached components for damage. Do not operate if damage is found. Operate the unit through the normal range of movements. Unit must operate smoothly without sticking, binding or abnormal noises.
3 Months (Maintenance Personnel)	Inspect parallel links, bushings and extension arm. Clean or replace parts as required.
Yearly (Maintenance Personnel)	Inspect pivot assembly. Check all supporting members, including the clamps, fasteners, nuts, cylinder, tool holder, etc. for indications of damage or wear. Repair or replace as required.

Adjustments

Refer to the "INSTALLATION" section for regulator, spring retract and lower pivot arm adjustments.

General Maintenance

1. Lower tool to lowest position or suitable support surface.
2. Turn off and lock out the air supply.
3. Bleed all pressure from air cylinder or rotate regulator control knob counterclockwise completely.

Remove Lower Arm from Base

Refer to Dwg. MHP1754 on page 16.

1. Complete General Maintenance procedures.
2. Loosen the spring adjustment collar (20) at the lower arm pivot and the upper arm pivot assemblies.
3. Remove the pivot mount locknut (24) and washer (23) at the lower arm pivot.
4. Use care not to damage the bearings. Remove the tool arm assembly from the base. Lay the arm on a sturdy work surface.

Remove Upper Arm from Lower Arm

Refer to Dwg. MHP1754 on page 16.

1. Complete General Maintenance procedures.
2. Loosen the spring adjustment collar (20) at the lower arm pivot and the upper arm pivot assemblies.
3. Remove the locknut (24) and washer (23) from the upper pivot mount.
4. Use care not to damage the bearings. Remove the upper arm from the lower arm.

Lower Arm Reconfiguration

Refer to Dwg. MHP1754 on page 16.

1. Complete General Maintenance procedures.
2. Complete 'Remove Upper Arm from Lower Arm' procedures.
3. Use care not to damage the bearings. Remove the upper arm from the lower arm.
4. Complete 'Remove Lower Arm from Base' procedures.
5. Use care not to damage the bearings. Remove the lower arm assembly from the base.
6. Install lower arm to obtain desired angle refer to MHP1767 on page 4.

Upper Arm Removal

Refer to Dwg. MHP1772 on page 7.

1. Complete General Maintenance procedures.
2. Support the tool extension arm (8).
3. Remove capscrews (5) and locknuts (6) from the end of arm adapter block (4).
4. Remove the tool extension arm. Support the weight of the upper arm assembly.
5. Remove capscrews (12) and locknuts (26) from the lower arm adapter block.
6. Remove the upper arm assembly.

Parallel Link and Bushing Replacement

Refer to MHP1772 on page 7.

1. Complete General Maintenance procedures.
2. Support the weight of the arm.
3. Remove screws (15) from parallel links (1).
4. Remove parallel links (1).
5. Use a punch of suitable size and material to avoid damage to pivot shaft (3). Lightly tap pivot shaft out of bushing (2).
6. Use a punch of suitable size and material to avoid damage to bushing (2). Lightly tap bushing out of adapter block (4).

7. Replace bushing. Lightly tap bushing into place. Use care not to misalign the bushing.
8. Replace parallel link.
9. Install screws (15) and tighten until snug.

Air Cylinder Replacement

Refer to MHP1772 on page 7.

1. Lower arm to full down position or rest tool on a suitable support.
2. Complete General Maintenance procedures.
3. Remove air fitting (14) from air cylinder cap end.
4. Remove the spring clip from the air cylinder rod end fixture pin (7).
5. Remove fixture pin (7) and bushings (9) from air cylinder rod end.
6. Raise the arm high enough to access the air cylinder cap end and support the arm in this position.
7. Remove the spring clip from the fixture pin at the air cylinder cap end.
8. Remove the fixture pin from the air cylinder.
9. Remove air cylinder (11).
10. Remove air cylinder rod end clevis from air cylinder.
11. Remove breather (10) from air cylinder. Install on replacement air cylinder.
12. Install air cylinder rod end clevis on replacement air cylinder.
13. Replace the air cylinder and install air cylinder cap end fixture pin.
14. Install spring clip to air cylinder cap end fixture pin (7).
15. Lower the arm to the full down position.
16. Align air cylinder rod end clevis with bracket (13) pin hole.
17. Install air cylinder rod end fixture pin (7) and bushings (9).
18. Install the spring clip to the air cylinder rod end fixture pin.
19. Install the air fitting to the air cylinder cap end.
20. Turn on air supply.
21. Perform Regulator Adjustment procedure. Refer to 'Operational Adjustments' on page 9.

Pivot Bearing Replacement

This applies to either the upper or lower arm pivot bearings. Refer to Dwg. MHP1754 on page 16.

1. Perform General Maintenance procedures.
2. Loosen retract spring tension. Refer to Retract Spring Adjustment procedure in "INSTALLATION" section.
3. Support the weight of the arm.
4. Remove locknut (24) and washer (23) from mounting shaft (16).
5. Remove lower pivot arm (22) section from mounting shaft (16), or remove upper pivot arm (22) and mounting shaft (16) from lower pivot arm (22).
6. Inspect bearing (18) for damage and tightness of rotation.
7. Remove and replace bearings if required.

Cleaning, Inspection and Repair

Examine disassembled components and fasteners for wear or damage. If worn or damaged, do not reuse. During reassembly all damaged and worn components should be replaced to prevent component failure, which may result in injury or property damage.

Use the following procedures to clean, inspect and repair the Tool Arm and associated equipment.

Cleaning

Thoroughly clean all Tool Arm components in solvent. The use of a stiff bristle brush will facilitate the removal of accumulated dirt and sediments on the arms. Wipe off each part after cleaning.

Inspection

All disassembled parts should be inspected to determine their fitness for continued use. Pay particular attention to the following:

1. Inspect all threaded items and replace those having damaged threads.
2. Inspect bushings and replace any bushings that are worn.
3. Check that bearings rotate freely.

Repair

Actual repairs are limited to the removal of small burrs and other minor surface imperfections. Use a fine stone or emery cloth for this work.

1. Worn or damaged parts must be replaced. Refer to the "PARTS" section for specific replacement parts information.
2. Inspect all remaining parts for evidence of wear or damage. Replace or repair any part that is in questionable condition. The cost of the part is often minor in comparison with the cost of redoing the job.
3. When fastening components, always use Loctite® 243 on capscrew threads.

Testing

Prior to initial use, all new, altered or repaired Tool Arms shall be tested to ensure proper operation.

1. Check Tool Arm movement through full operational range. Ensure movement is smooth and without binding. Ensure there are no obstructions through the operating range.
2. Install tool expected to be used. Check position and regulator adjustments.

PARTS ORDERING INFORMATION

The Light Duty Tool Arm is designed and constructed to provide long, trouble-free service. In time it may become necessary to order and install new parts to replace those that have been subjected to wear.

Use of replacement parts other than **Ingersoll-Rand** Material Handling may result in decreased performance, and may, at the company's option invalidate the warranty. For prompt service and genuine **Ingersoll-Rand** Material Handling parts, provide your nearest Distributor with the following:

1. Complete unit model number or description.
2. Part number and part description as shown in this manual.
3. Quantity required.

For your convenience and future reference it is recommended that the following information be recorded:

Model _____

Date Purchased _____

Returned Goods Policy

Ingersoll-Rand will not accept any returned goods for warranty or service work unless prior arrangements have been made and written authorization has been provided from the location where the goods were purchased.

NOTICE

• **Continuing improvement and advancement of design may produce changes to this Tool Arm that are not included in this manual. Manuals are periodically revised to incorporate changes. Always check the manual edition number on the front cover for the latest issue.**

Disposal

When the life of the unit has expired, it is recommended that the unit be disassembled, degreased and parts separated as to materials so that they may be recycled.

For additional information contact:

Ingersoll-Rand
Zimmerman Handling Systems
 29555 Stephenson Highway
 Madison Heights, MI 48071-2387
 Phone: (248) 398-6200
 Fax: (248) 398-1374

or

Ingersoll-Rand Company
Douai Operations
 111, avenue Roger Salengro
 59450 Sin Le Noble, France
 Phone: (33) 3-27-93-08-08
 Fax: (33) 3-27-93-08-00

For additional information on the following products, order publication by the referenced Part/Document Number listed:

Publication	Part/Document Number	Publication	Part/Document Number
Medium Duty Tool Arm	MHD56176	Z Rail System	MHD56169
E-Z Torque Tube	MHD56172	Valu-Trak Rail System	MHD56161

LIGHT DUTY TOOL ARM ASSEMBLY PARTS DRAWING

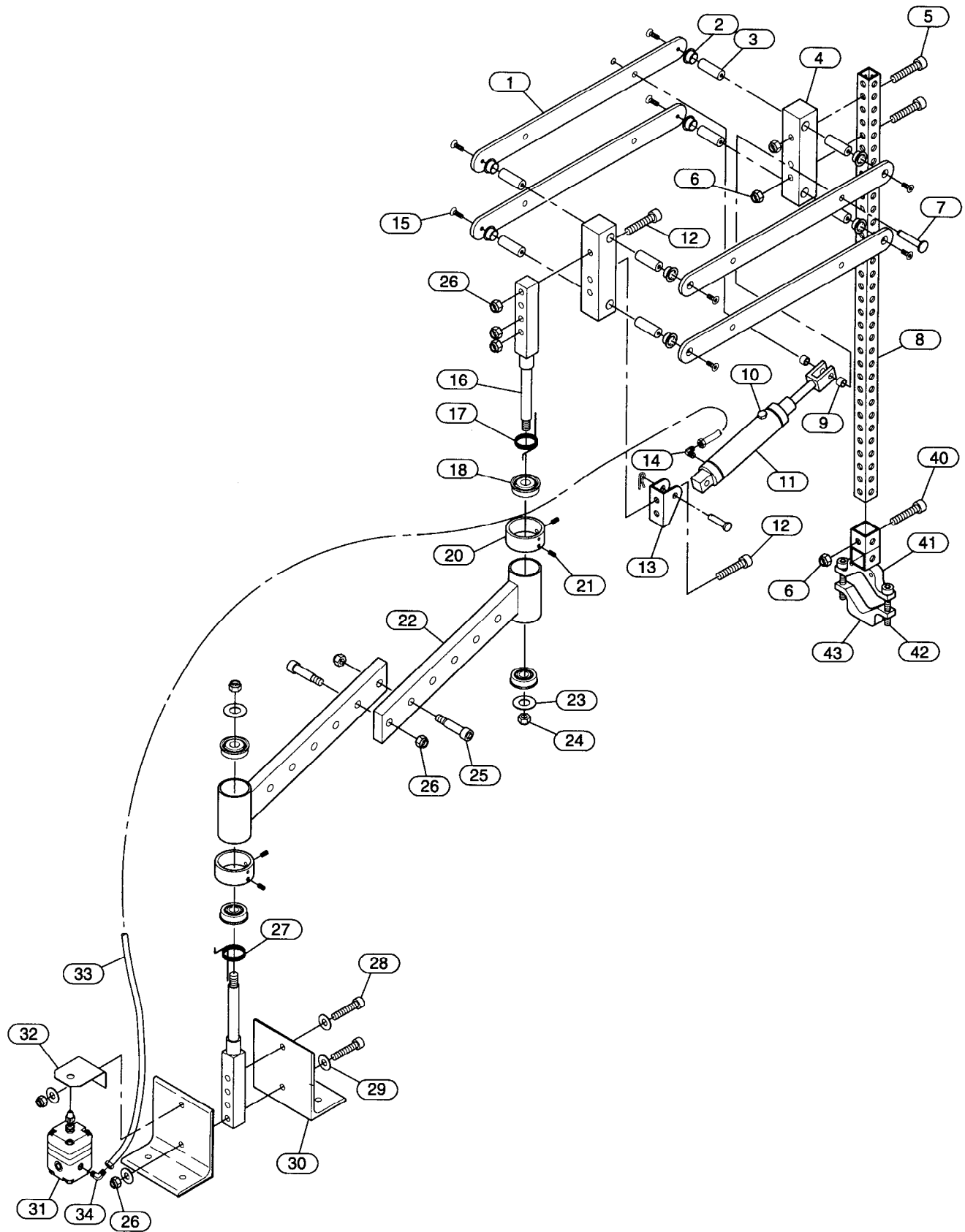

(Dwg. MHP1754)

LIGHT DUTY TOOL ARM ASSEMBLY PARTS LIST

ITEM NO.	DESCRIPTION OF PART	QTY TOTAL	PART NUMBER
*	Light Duty Tool Arm with Tool Holder	1	EZTA080500
	Light Duty Tool Arm without Tool Holder	1	43146000
1	Parallel Links	4	43146002
• 2	Bushing, Flanged	8	65086
3	Pivot Shaft	8	43146005
4	Adapter Block	2	43146003
5	Capscrew (M8 x 1.25 x 75 mm)	2	74212
6	Locknut (M8 x 1.25 mm)	3	75616
7	Pin, Fixture	1	30233
8	Extension Arm	1	43146009
9	Bushing	2	65128
10	Breather	1	93884
11	Cylinder	1	55603
12	Capscrew (M10 x 1.5 x 80 mm)	3	74213
13	Bracket	1	117523-15
14	Fitting, Elbow	1	93971
15	Screw (M6 x 1 x 15 mm)	8	74209
16	Mounting Shaft	2	43146004
• 17	Spring	1	43146012
18	Bearing, Flanged	4	65132
20	Collar	2	43146007
21	Setscrew (M6 x 1 x 7 mm cup pt.)	2	74208
22	Pivot Arm	2	43146001
23	Flat Washer (M12)	2	74574M
24	Locknut (M12 x 1.75 mm)	2	75587M
25	Shoulder Bolt (M12 x 60 mm)	2	74211
26	Locknut (M10 x 1.25 mm)	7	75583M
27	Spring	1	43146013
28	Capscrew (M10 x 1.5 x 55 mm)	2	74210
29	Flat Washer (M10)	4	74540M
30	Mounting Bracket	2	43140006
31	Regulator (includes check valve)	1	13825
32	Bracket	1	43146008
33	Tube (0.25 Poly x 1.5 m (5 ft.))	1	93961-B
34	Fitting, Elbow	1	93972
40	Capscrew (M8 x 1.25 x 45 mm)	1	74215
41	Tool Holder	1	43146010
42	Capscrew (M8 x 1.25 x 55 mm)	2	74214
43	Tool Clamp	1	43163

• Recommended Spare.

* The Light Duty Tool Arm is available with or without tool holder shown. Optional tool holders are shown on page 18.

OPTIONS, ATTACHMENTS AND ACCESSORIES

Tool Holders

ITEM NO.	PART NUMBER	DESCRIPTION OF PART	WEIGHT	
			kg	lb
---	Contact	Fixed horizontal/vertical (Two Axis)*	0.9	2
100	Factory	360° Tool Holder (Three Axis)	2.27	5

* Refer to Dwg. MHP1754 on page 16 for parts.

Accepts tools from 19 to 63 mm (3/4 to 2-1/2 in.) diameter.

**360°
Tool Holder**

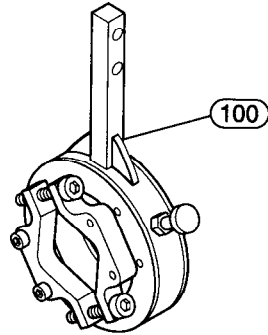

(Dwg. MHP1852)

**Two Axis
Tool Holder**

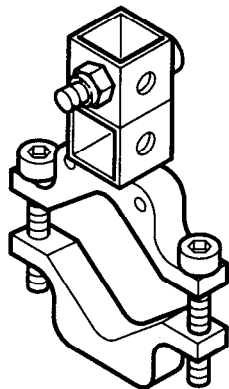

(Dwg. MHP1773)

Swivel

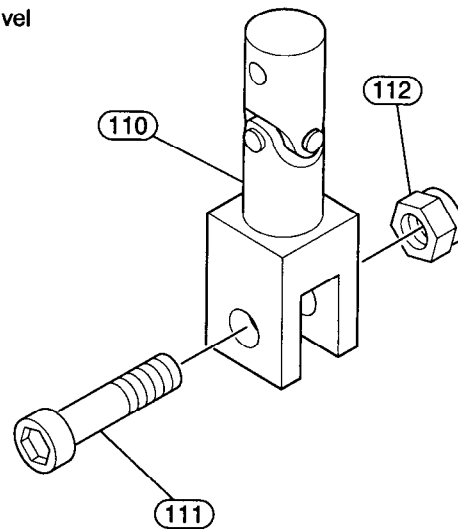

(Dwg. MHP1810)

Swivel Parts List

ITEM NO.	DESCRIPTION OF PART	QTY TOTAL	PART NUMBER
110	Swivel Assembly (Incl's items 101 and 102)	1	43168
111	Bolt, 0.375 x 1 in. long	1	71441
112	Locknut	1	75518

Accessories

DESCRIPTION OF ACCESSORY	PART NUMBER
Tool air supply package, 1/4 in.	90014
Filter/Regulator, 1/4 in. Compact Series	B18-02-FKG0-28
Filter/Regulator, 3/8 in. Compact Series	B18-03-FKG0-28
Filter/Regulator, 1/2 in. Compact Series	B18-04-FKG0-28

WARRANTY

Limited Warranty

Ingersoll-Rand Company (I-R) warrants to the original user its Hoists and Winches (Products) to be free of defects in material and workmanship for a period of one year from the date of purchase. **I-R** will repair, without cost, any Product found to be defective, including parts and labor charges, or at its option, will replace such Products or refund the purchase price, less a reasonable allowance for depreciation, in exchange for the Product. Repairs or replacements are warranted for the remainder of the original warranty period.

If any Product proves defective within its original one year warranty period, it should be returned to any Authorized Hoist and Winch Service Distributor, transportation prepaid with proof of purchase or warranty card.

This warranty does not apply to Products which **I-R** has determined to have been misused or abused, improperly maintained by the user, or where the malfunction or defect can be attributed to the use of non-genuine **I-R** parts.

I-R makes no other warranty, and all implied warranties including any warranty of merchantability or fitness for a particular purpose are limited to the duration of the expressed warranty period as set forth above. I-R's maximum liability is limited to the purchase price of the Product and in no event shall I-R be liable for any consequential, indirect, incidental or special damages of any nature rising from the sale or use of the Product, whether based on contract, tort, or otherwise.

Note: Some states do not allow limitations on incidental or consequential damages or how long an implied warranty lasts so that the above limitations may not apply to you.

This warranty gives you specific legal rights and you may also have other rights which may vary from state to state.

Important Notice

It is our policy to promote safe delivery of all orders.

This shipment has been thoroughly checked, packed and inspected before leaving our plant and receipt for it in good condition has been received from the carrier. Any loss or damage which occurs to this shipment while en route is not due to any action or conduct of the manufacturer.

Visible Loss or Damage

If any of the goods called for on the bill of lading or express receipt are damaged or the quantity is short, do not accept them until the freight or express agent makes an appropriate notation on your freight bill or express receipt.

Concealed Loss or Damage

When a shipment has been delivered to you in apparent good condition, but upon opening the crate or container, loss or damage has taken place while in transit, notify the carrier's agent immediately.

Damage Claims

You must file claims for damage with the carrier. It is the transportation company's responsibility to reimburse you for repair or replacement of goods damaged in shipment. Claims for loss or damage in shipment must not be deducted from the **Ingersoll-Rand** invoice, nor should payment of **Ingersoll-Rand** invoice be withheld awaiting adjustment of such claims as the carrier guarantees safe delivery.

You may return products damaged in shipment to us for repair, which services will be for your account and form your basis for claim against the carrier.

United States Office Locations

For Order Entry and Order Status:

**Ingersoll-Rand
Zimmerman Handling
Systems**
29555 Stephenson Highway
Madison Heights, MI
48071-2387
Phone: (248) 398-6200
Fax: (248) 398-1374

For Technical Support:

**Ingersoll-Rand Company
Douai Operations**
111, avenue Roger Salengro
59450 Sin Le Noble, France
Phone: (33) 3-27-93-08-08
Fax: (33) 3-27-93-08-00

Web Site:
www.ingersoll-rand.com

Regional Sales Offices:

Chicago, IL
888 Industrial Drive
Elmhurst, IL 60126
Phone: (630) 530-3800
Fax: (630) 530-3891

Detroit, MI
23192 Commerce Drive
Farmington Hills, MI 48335
Phone: (248) 476-6677
Fax: (248) 476-6670

Houston, TX
450 Gears Road,
Suite 210
Houston, TX 77067-4516
Phone: (281) 872-6800
Fax: (281) 872-6807

Los Angeles, CA
11909 E. Telegraph Road
Santa Fe Springs, CA
90670-0525
Phone: (562) 948-4189
Fax: (562) 948-1828

Philadelphia, PA
P.O. Box 425
900 E. 8th Avenue, Suite 103
King of Prussia, PA 19406
Phone: (610) 337-5930
Fax: (610) 337-5912

International Office Locations

Offices and distributors in principal cities throughout the world. Contact the nearest **Ingersoll-Rand** office for the name and address of the distributor in your country or write/fax to:

**Ingersoll-Rand
Zimmerman Handling
Systems**
29555 Stephenson Highway
Madison Heights, MI
48071-2387
Phone: (248) 398-6200
Fax: (248) 398-1374

**Canada
National Sales Office
Regional Warehouse
Toronto, Ontario**
51 Worcester Road
Rexdale, Ontario
M9W 4K2
Phone: (416) 213-4500
Fax: (416) 213-4510

Order Desk:
Fax: (416) 213-4506

Regional Sales Offices:

Edmonton, Alberta
1430 Weber Center
5555 Calgary Trail NW
Edmonton, Alberta
T6H 2P9
Phone: (403) 438-5039
Fax: (403) 437-3145

Montreal, Quebec
3501 St. Charles Blvd.
Kirkland, Quebec
H9H 4S3
Phone: (514) 695-9040
Fax: (514) 695-0963

British Columbia
1200 Cliveden Avenue,
Delta, British Columbia
V3M 6G4
Phone: (604) 523-0803
Fax: (604) 523-0801

**Latin America Operations
Ingersoll-Rand
Production Equipment
Group**
730 NW 107th Avenue,
Suite 300
Miami, FL
33172-3107 USA
Phone: (305) 559-0500
Fax: (305) 222-0864

**Europe, Middle East and
Africa
Ingersoll-Rand Company
Douai Operations**
111, avenue Roger Salengro
59450 Sin Le Noble, France
Phone: (33) 3-27-93-08-08
Fax: (33) 3-27-93-08-00

**Asia Pacific Operations
Ingersoll-Rand Ltd.**
Suite 1201-3 12/F
Central Plaza
18 Harbour Road
Wanchai, Hong Kong
Phone: (852) 9794 1673
Fax: (852) 9794 7895

**Russia
Ingersoll-Rand Company**
Kuznetsky Most, 21/5
Entrance 3
Moscow, 103895
Russia
Phone: (7) 501 923 9134
Fax: (7) 501 924 4625