

# PARTS, OPERATION, AND MAINTENANCE MANUAL for MANIPULATOR ARM

**700C**                      **MODELS**                      **720**  
   **713**

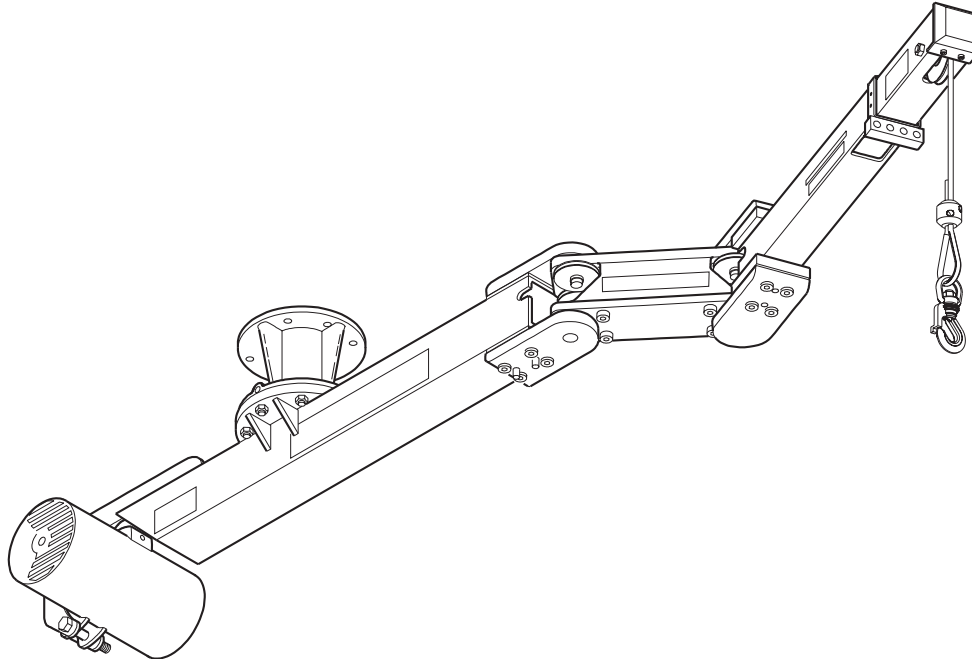

(Dwg. MHP1568)

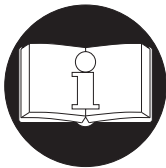

**READ THIS MANUAL BEFORE USING THESE PRODUCTS.** This manual contains important safety, installation, and maintenance information. Make this manual available to all persons responsible for the installation, operation and maintenance of these products.

**⚠ WARNING**

This equipment is intended for industrial use only and should not be used for lifting, supporting, or transporting people or lifting or supporting loads over people.

Always operate, inspect and maintain this unit in accordance with applicable safety codes and regulations.

# TABLE OF CONTENTS

Description	Page No.
<b>Safety Information</b>	
Danger, Warning, Caution, and Notice .....	3
Safety Summary.....	3
<b>Safe Operating Instructions</b> .....	4
<b>Specifications</b> .....	4
<b>Installation</b>	
Mounting .....	7
Air System .....	7
<b>Operation</b>	
Description of Operation .....	8
Balancer Operation .....	8
Control Operation .....	8
Manipulator Arm Operation .....	8
Operation Adjustments .....	9
Lash-Up .....	10
Yarding .....	10
<b>Inspection</b>	
Records and Reports .....	11
Wire Rope Reports.....	11
Frequent Inspections .....	11
Periodic Inspection .....	11
Units Not in Regular Use.....	12
<b>Lubrication</b> .....	12
<b>Troubleshooting</b> .....	13
<b>Inspection and Maintenance Report</b> .....	14
<b>Maintenance</b>	
Maintenance Intervals.....	15
Wire Rope Replacement .....	15
Disassembly .....	15
Cleaning, Inspection and Repair .....	16
Assembly .....	16
Testing .....	17
Manipulator Arm 700C Assembly Parts Drawing.....	18
Manipulator Arm 700C Assembly Parts List .....	19
Pivot Column Mount Assembly Drawing and Parts List .....	21
Manipulator Arm 713 and 720 Assembly Parts Drawing.....	22
Manipulator Arm 713 Assembly Parts List .....	23
Carriage Assembly Drawing and Parts List .....	24
<b>Parts Ordering Information</b>	
Return Goods Policy .....	26
<b>Warranty</b> .....	27
<b>Office Locations</b> .....	28

## SAFETY INFORMATION

This manual provides important information for all personnel involved with the safe installation, operation, and proper maintenance of this product. Even if you feel you are familiar with this or similar equipment, you should read this manual before operating the product.

### Danger, Warning, Caution, and Notice

Throughout this manual there are steps and procedures which, if not followed, may result in a hazard. The following signal words are used to identify the level of potential hazard.

#### DANGER

Danger is used to indicate the presence of a hazard which *will* cause *severe* injury, death, or substantial property damage if the warning is ignored.

#### WARNING

Warning is used to indicate the presence of a hazard which *can* cause *severe* injury, death, or substantial property damage if the warning is ignored.

#### CAUTION

Caution is used to indicate the presence of a hazard which *will* or *can* cause injury or property damage if the warning is ignored.

#### NOTICE

Notice is used to notify people of installation, operation, or maintenance information which is important but not hazard-related.

### Safety Summary

Personal protective and safety equipment required by the operator's surrounding environment must be used and maintained in accordance with manufacturer's instructions.

#### WARNING

- **Do not use this unit or attached equipment for lifting, supporting, or transporting people or lifting or supporting loads over people.**
- **The supporting structures and load-attaching devices used in conjunction with these units must provide a safety factor of at least three times the rated capacity of the unit. This is the customer's responsibility. If in doubt, consult a registered structural engineer.**
- **If system air pressure is lost, lower the load immediately. The operator must stay out of the vertical path of the load.**

### NOTICE

- **Lifting equipment is subject to different regulations in each country. These regulations may not be specified in this manual.**

The National Safety Council, Accident Prevention Manual for Industrial Operations, Eighth Edition and other recognized safety sources make a common point: Employees who work near suspended loads or assist in hooking on or arranging a load should be instructed to keep out from under the load. From a safety standpoint, one factor is paramount: conduct all operations in such a manner that if there were an equipment failure, no personnel would be injured. This means keep out from under a raised load and keep out of the line of force of any load.

The Occupational Safety and Health Act of 1970 generally places the burden of compliance with the owner/employer, not the manufacturer. Many OSHA requirements are not concerned or connected with the manufactured product but are, rather, connected with the final installation. It is the owner's and user's responsibility to determine the suitability of a product for any particular use. It is recommended that all applicable industry, trade association, federal, state and local regulations be checked. Read all operating instructions and warnings before operation.

This manual has been produced by **Ingersoll-Rand** to provide dealers, mechanics, operators and company personnel with the information required to install, operate, maintain and repair the products described herein.

It is extremely important that mechanics and operators be familiar with the servicing procedures of these products, or like or similar products, and are physically capable of conducting the procedures. These personnel shall have a general working knowledge that includes:

1. Proper and safe use and application of mechanics common hand tools as well as special **Ingersoll-Rand** or recommended tools.
2. Safety procedures, precautions and work habits established by accepted industry standards.

**Ingersoll-Rand** cannot know of, or provide all the procedures by which product operations or repairs may be conducted and the hazards and/or results of each method. If operation or maintenance procedures not specifically recommended by the manufacturer are conducted, it must be ensured that product safety is not endangered by the actions taken. If unsure of an operation or maintenance procedure or step, personnel should place the product in a safe condition and contact supervisors and/or the factory for technical assistance.

## SAFE OPERATING INSTRUCTIONS

The following warnings and operating instructions are intended to avoid unsafe operating practices which might lead to injury or property damage.

**Ingersoll-Rand** recognizes that most companies who use material handling equipment have a safety program in force at their facility. If you are aware that some conflict exists between a rule set forth in this publication and a similar rule already set by an individual company, the more stringent of the two should take precedence.

The manual supports a fully installed system. Operators should be familiar with the operation of the controls before using the system.

Safe Operating Instructions are provided to make an operator aware of dangerous practices to avoid and are not necessarily limited to the following list. Refer to specific sections in the manual for additional safety information.

1. Only allow personnel trained in, safety and operation on this product to operate and maintain the balancer.
2. Only operate a balancer if you are physically fit to do so.
3. When a **“DO NOT OPERATE”** sign is placed on the balancer controls, do not operate unit until sign has been removed by designated personnel.
4. Do not use unit if hook latch has been sprung or broken.
5. Before each shift, check unit for wear and damage. Never use a unit that inspection indicates is worn or damaged.
6. Never lift a load greater than rated capacity of unit. Refer to capacity labels attached to the unit.
7. Only operate the unit when the wire rope is centered over the load. Do not “side pull” or “yard”.
8. Never operate unit with twisted, kinked or damaged wire rope.
9. Never run wire rope over a sharp edge.
10. Pay attention to the load at all times when operating the unit.
11. Make sure everyone is clear of the load path. Do not lift a load over people.
12. Never use the unit for lifting or lowering people, and never allow anyone to stand on a suspended load.
13. Never weld or cut a load suspended by the unit.
14. Do not operate the unit if wire rope is jumping, or if excessive noise, jamming, overloading, or binding occurs.
15. Shut off air supply before performing any maintenance.
16. Avoid collision or bumping of the units.
17. Do not turn continuously in one direction when using the arm.
18. Do use good posture when operating the system.
19. Do check air connections for leakage.

## SPECIFICATIONS

Manipulator arms consist of a connecting linkage type boom that folds within itself to offer a large coverage area, these arms utilize the Balance Air® lifting and balancing unit as the lifting power.

### Series 700C Arm - Column/Ceiling Mounted

Part No.	Arm Length		Capacity		Weight	
	ft	m	lbs	kg	lbs	kg
70015A**Z0613	6	1.83	150	65	xx	xx
70015A**Z0713	7	2.13			xx	xx
70015A**Z0813	8	2.44			xx	xx
70015A**Z0913	9	2.74			xx	xx
70015A**Z1013	10	3.05			xx	xx
70020A**Z0613	6	1.83	200	90	xx	xx
70020A**Z0713	7	2.13			xx	xx
70020A**Z0813	8	2.44			xx	xx
70020A**Z0913	9	2.74			xx	xx
70020A**Z1013	10	3.05			xx	xx
70035A**Z0613	6	1.83	350	155	xx	xx
70035A**Z0713	7	2.13			xx	xx
70035A**Z0813	8	2.44			xx	xx
70050A**Z0613	6	1.83			500	225

\*\* When ordering, please specify mounting option desired:  
 T00 = Ceiling mount  
 B00 = Column mount

### Series 700C Arm - Carriage Mounted

Part No.	Arm Length		Capacity		Weight	
	ft	m	lbs	kg	lbs	kg
70015A**Z0600	6	1.83	150	65	xx	xx
70015A**Z0700	7	2.13			xx	xx
70015A**Z0800	8	2.44			xx	xx
70015A**Z0900	9	2.74			xx	xx
70015A**Z1000	10	3.05			xx	xx
70020A**Z0600	6	1.83	200	90	xx	xx
70020A**Z0700	7	2.13			xx	xx
70020A**Z0800	8	2.44			xx	xx
70020A**Z0900	9	2.74			xx	xx
70020A**Z1000	10	3.05			xx	xx
70035A**Z0600	6	1.83	350	155	xx	xx
70035A**Z0700	7	2.13			xx	xx
70035A**Z0800	8	2.44			xx	xx
70050A**Z0600	6	1.83			500	225

\*\* When ordering, please specify mounting option desired:  
 CA1 = Carriage A1 (A1 available only in 6, 7, 8 ft [1.83, 2.13, 2.44 m] lengths / 150 and 200 lbs [65 and 90 kg] capacity)  
 CA2 = Carriage A2  
 CS3 = Carriage S3  
 CE8 = Carriage ETA8  
 CS2 = Carriage S2  
 CTR = Carriage T-Rail

**Series 713 Arm - Column/Ceiling Mounted**

Part No.	Arm Length		Capacity		Weight	
	ft	m	lbs	kg	lbs	kg
71315A**Z0613	6	1.83	150	65	xx	xx
71315A**Z0713	7	2.13			xx	xx
71315A**Z0813	8	2.44			xx	xx
71315A**Z0913	9	2.74			xx	xx
71315A**Z1013	10	3.05			xx	xx
71320A**Z0613	6	1.83	200	90	xx	xx
71320A**Z0713	7	2.13			xx	xx
71320A**Z0813	8	2.44			xx	xx
71320A**Z0913	9	2.74			xx	xx
71320A**Z1013	10	3.05			xx	xx
71335A**Z0613	6	1.83	350	155	xx	xx
71335A**Z0713	7	2.13			xx	xx
71335A**Z0813	8	2.44			xx	xx
71335A**Z0913	9	2.74			xx	xx
71335A**Z1013	10	3.05			xx	xx
71350A**Z0613	6	1.83	500	225	xx	xx
71350A**Z0713	7	1.83			xx	xx
71350A**Z0813	8	1.83			xx	xx

**Series 713 Arm - Carriage Mounted**

Part No.	Arm Length		Capacity		Weight	
	ft	m	lbs	kg	lbs	kg
71315A**Z0600	6	1.83	150	65	xx	xx
71315A**Z0713	7	2.13			xx	xx
71315A**Z0800	8	2.44			xx	xx
71315A**Z0900	9	2.74			xx	xx
71315A**Z1000	10	3.05			xx	xx
71320A**Z0600	6	1.83	200	90	xx	xx
71320A**Z0713	7	2.13			xx	xx
71320A**Z0800	8	2.44			xx	xx
71320A**Z0900	9	2.74			xx	xx
71320A**Z1000	10	3.05			xx	xx
71335A**Z0600	6	1.83	350	155	xx	xx
71335A**Z0713	7	2.13			xx	xx
71335A**Z0800	8	2.44			xx	xx
71350A**Z0600	6	1.83	500	225	xx	xx
71350A**Z0713	7	2.13			xx	xx
71350A**Z0800	8	2.44			xx	xx

**Series 720 Arm - Column/Ceiling Mounted**

Part No.	Arm Length		Capacity		Weight	
	ft	m	lbs	kg	lbs	kg
72015A**Z0613	6	1.83	150	65	xx	xx
72015A**Z0713	7	2.13			xx	xx
72015A**Z0813	8	2.44			xx	xx
72015A**Z0913	9	2.74			xx	xx
72015A**Z1013	10	3.05			xx	xx

\*\* When ordering, please specify mounting option desired:

T00 = Ceiling mount

B00 = Column mount

**Series 720 Arm - Carriage Mounted**

Part No.	Arm Length		Capacity		Weight	
	ft	m	lbs	kg	lbs	kg
72015A**Z0600	6	1.83	150	65	xx	xx
72015A**Z0700	7	2.13			xx	xx
72015A**Z0800	8	2.44			xx	xx
72015A**Z0900	9	2.74			xx	xx
72015A**Z1000	10	3.05			xx	xx

\*\* When ordering, please specify mounting option desired:

CA1 = Carriage A1 (A1 available only in 6, 7, 8 ft [1.83, 2.13, 2.44 m] lengths / 150 lbs [65 kg] capacity)

CA2 = Carriage A2

CS3 = Carriage S3

CE8 = Carriage ETA8

CS2 = Carriage S2

CTR = Carriage T-Rail

**Model Code Explanation**

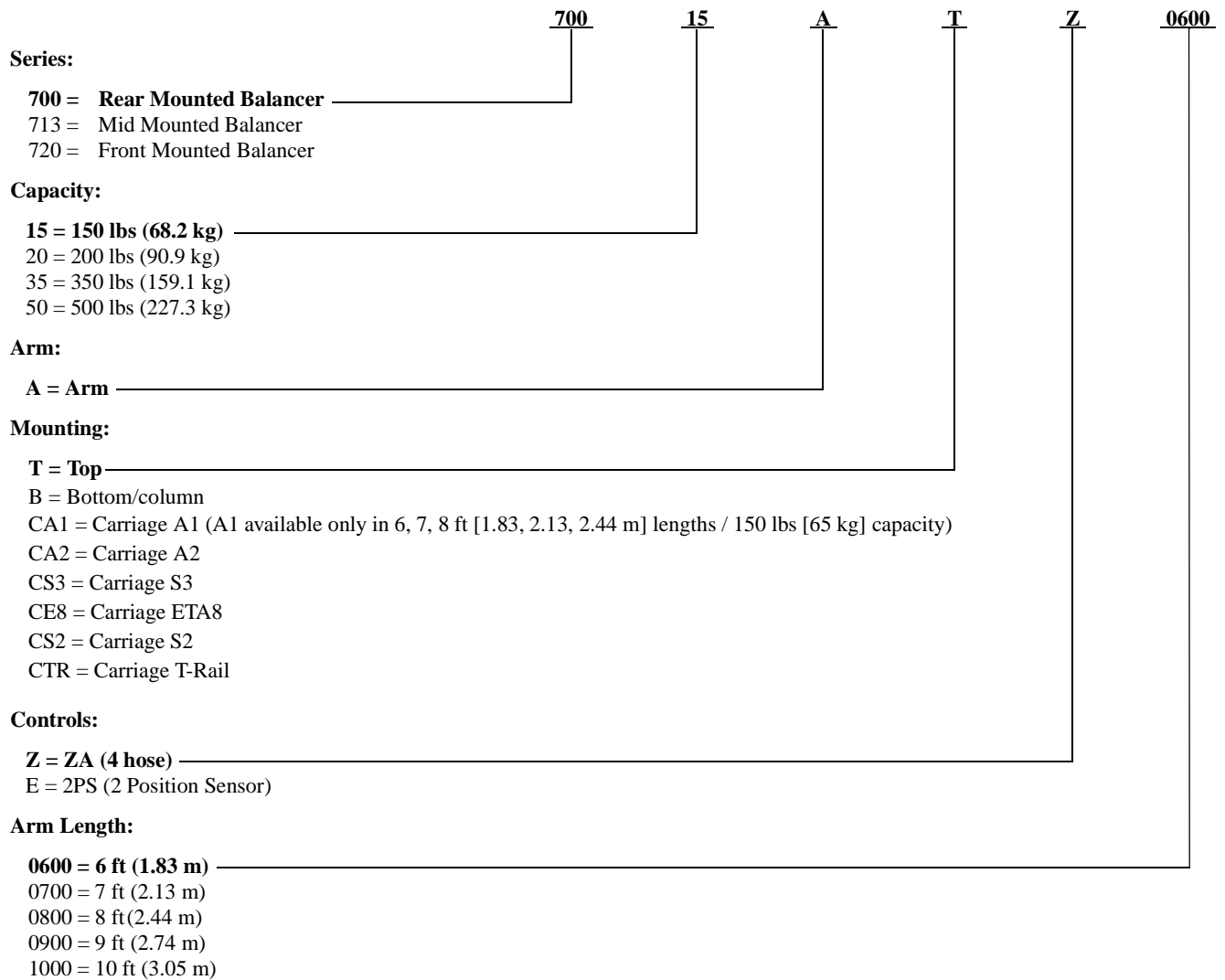

**WARNING LABEL**

Each Manipulator Arm is supplied from the factory with the warning label shown. If the warning label is not attached to your Manipulator Arm, order a new label and install it. Refer to parts list for part number. Read and obey all warnings and other safety information attached to the Manipulator Arm. Warning label may not be shown actual size. The warning label must be clearly visible at all times.



(Part number 54115993)

# INSTALLATION

Prior to installing unit, carefully inspect it for possible shipping damage. Units are supplied fully lubricated from the factory.

## ⚠ CAUTION

- Owners and users are advised to examine specific, local or other regulations, including American National Standards Institute and/or OSHA Regulations which may apply to a particular type of use of this product before installing or putting the unit into use.
- A falling load can cause injury or death. Before installing, read "SAFETY INFORMATION".

## Mounting

Make certain unit is properly installed. A little extra time and effort in doing so can contribute a lot toward preventing accidents and helping you get the best service possible.

Always make certain supporting member from which unit is suspended is strong enough to support the weight of the unit plus the weight of a maximum rated load plus a generous factor of at least 300% of the combined weights. If in doubt, contact a registered structural engineer.

Securely mount unit to support using six or fourteen 1/2-13 grade 8 capscrews and torque to 76 ft lb (103 Nm) dry or 57 ft lb (77 Nm) lubricated.

## Air System

The air supply system should be purged for a minimum of 30 seconds prior to connection of the balancer and controls. This will remove any debris from air lines and help prevent damage to controls at start up.

## ⚠ WARNING

- Do not exceed 100 psig (6.9 bar/690 kPa) inlet pressure. Do not use a lubricator of any kind. Oil will damage internal components.
- The air supply must be clean and free from water and water vapor.

## Air Lines

The inside diameter of the unit air supply lines must not be smaller than 3/8 inch (10 mm) based on a maximum of 100 feet (30 m) between the air supply and the unit. Contact the factory for recommended air line sizes for distances greater than 100 feet (30 m). Before making final connections, all air supply lines should be purged before connecting to unit inlet. Supply lines should be as short and straight as installation conditions will permit. Long transmission lines and excessive use of fittings, elbows, tees, globe valves, etc. cause a reduction in pressure due to restrictions and surface friction in the lines. If quick-disconnect fittings are used at the inlet of the unit, they must have at least a 3/16 inch (10 mm) air passage. Use of smaller fittings will reduce performance.

## Connection of Air Lines

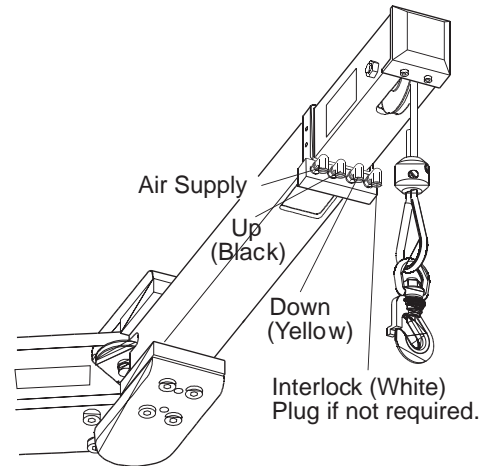

(Dwg. MHP1902)

## ZA Control

The control hose is pre-assembled to the Manipulator Arm. Control hoses are black, yellow and white precoiled hose assemblies. The yellow hose must be connected to the down port of the ZA manifold. The black hose must be attached to the up port of the ZA manifold. The white hose must be installed in the pilot port of the balancer.

## 2PS Control (2 Position Sensor)

The control tubing is a tri-coil assembly. A black 3/8 inch (9.5 mm) tube supplies air to the handling device. A 5/32 inch (3.9 mm) tube supplies the pilot signal to the 2PS valve. Manipulator Arms with a hi-lo circuit utilize a yellow 3/8 inch (9.5 mm) tube.

## Air Line Filter

It is recommended that an air line strainer/filter be installed as close as practical to the unit air inlet port. The strainer/filter should provide 5 micron filtration and include a moisture trap. Clean strainer/filter monthly to maintain its operating efficiency.

To maintain dry air, the frequency for draining the filter should also be based on the condition of the air supply. We suggest the filter be drained weekly at first. Depending on air supply condition, a proper filter drain schedule should be established.

## Moisture in Air Lines

Moisture that reaches the unit through supply lines is the chief factor in determining the length of time between service overhauls. Moisture traps can help to eliminate moisture. Other methods, such as an air receiver which collects moisture before it reaches the unit controls or an aftercooler at the compressor that cools the air prior to distribution through the supply lines, are also helpful.

## Wire Rope

Retract wire rope completely into Balancer. Ensure wire rope is correctly reeved through Manipulator Arm pulleys. Ensure hook wire rope clamp does not contact pulley. Ensure wire rope end is not frayed, use plastic cap to prevent snagging and damage to air hoses.

# OPERATION

## Description Of Operation

The Manipulator Arm is an integrated group of components designed to maximize the interaction of man and machine. The Manipulator Arm mounts to an overhead beam or rail system and incorporates a **Zimmerman** balancer. The balancer has a wire rope with load hook which is fed through the Manipulator Arm to the work area. The operator controls the system by use of the **Zimmerman ZA** (Zim-Air) up and down control or the **Zimmerman 2PS** (2 Position Sensor) zero gravity control.

The system renders the load virtually weightless through the balancer's compressed air operation. When the Manipulator Arm is mounted to a rail system it provides for ease of horizontal movement. This combination requires little physical strength to operate and reduces operator fatigue.

## Balancer Operation

Energy used to power the balancer is compressed air, a minimum of 70 psig (4.8 bar/480 kPa) is required. Air is controlled by an external control package. Compressed air pushes against the piston, causing it to move laterally.

The piston pushes the reel assembly causing the reel to move laterally as well as rotate which winds the wire rope into the balancer, raising the hook or handling device. Compressed air is released through the controls to atmosphere and the reel rotates in the opposite direction lowering the hook or handling device.

The balancer reaches maximum capacity when 100 psig (6.9 bar/690 kPa) is applied. As air pressure decreases the unit capacity decreased proportionally. If 80 psig (5.5 bar/552 kPa) is applied to the balancer, maximum balancer operational capacity is 80% of rated capacity.

## Control Operation

The Manipulator Arm uses the **Zimmerman ZA** (Zim-Air) or **2PS** (2 Position Sensor) control package.

### ZA Control

The Zim-Air control package utilizes an up/down control pendant, connected to the manifold mounted to the balancer. The top of the manifold has two flow control valves, labeled "UP" and "DN". They control the speed with which a load will raise and lower. The center screw control is for "hook balance adjustment" to maintain the hook in a floating condition when it does not have a load on it.

Air is supplied through the manifold to the control pendant. When the "UP" lever is depressed, air passes through a passage in the pendant and into the balancer piston chamber resulting in the balancer raising the load. Lowering the load is accomplished by depressing the "DN" lever, which releases air in the balancer to atmosphere through the block, and lowers the load.

### 2PS (2 Position Sensor)

This style control utilizes the EA Regulator and Two Position Sensor Valve.

The EA Regulator provides a control circuit and a work circuit through the regulator for balancer operation. The trim valve is an adjustable flow control providing a (control circuit) regulated low volume of air to the main regulator. The main regulator provides a higher volume of air to the piston chamber of the balancer. The auxiliary flow control allows air to be bled to atmosphere to support a lighter load.

The Two Position Sensor Valve is a pilot operated, four way, spring return valve. Pilot signal is sent to the valve by a switch mounted on the handling device, or by a pilot line from the clamp circuit.

The EA Regulator controls operation of the balancer when the handling device has a load attached to it.

The Two Position Sensor Valve controls balancer operation when the handling device is empty by bleeding air pressure from the EA Regulator to atmosphere.

The pilot signal shifts the 2PS valve to a blocked port giving the EA Regulator full balancing control of the handling device and load. Once the load is placed and released, the spring return will overcome the pilot signal shifting the valve back to a bleed condition balancing the empty handling device.

## Manipulator Arm Operation

### WARNING

• **If system air pressure is lost, lower the load immediately. The operator must stay out of the path of the load. Clamp may lose force required to hold load resulting in injury.**

The "UP" and "DN" levers allow adjustable speed control. As lever is depressed further, operational speed increases. Use lever to 'throttle' speed to ensure controlled movement of the hook or handling device.

### CAUTION

• **Do not wrap control hoses around the wire rope. Damage to hoses and failure of unit may result.**

Raising and lowering of the load is dependent on the type of control circuit on the handling device. The Zim-Air (ZA) type control requires manual lever operation to raise and lower the device. If the handling device has a 2PS (2 Position Sensor) control, the device is in zero gravity with or without a load and requires the operator to push up or down to raise and lower the device.

1. Move Manipulator Arm to the pick up point, and position it over the load for pick up.
2. Slowly lower balancer and engage load until completely seated.
3. Raise load and maneuver to the set down point.
4. At the set down point lower the load.
5. Maneuver the Manipulator Arm back to the pick up point and repeat steps.

Positioning of the load is best accomplished by the operator, when moving away from the manipulator arm pivot point. Manipulator arm will freely follow.



## Operation Adjustments

### WARNING

- Air supply pressure must be a minimum of 70 psig (4.8 bar/480 kPa) and a maximum of 100 psig (6.9 bar/690 kPa). Excessive air pressure may damage the balancer or controls.
- Prior to adjustment of the controls, ensure air is off and wire rope is slack.
- Interlock should not be adjusted until all control adjustments have been completed. Interlock may not function properly if it is set before the controls.
- Screw type flow control and hook balance adjustment screws on the ZA manifold should never extend above manifold body. Thread engagement will be minimal and could result in screw being discharged from manifold.
- The 2PS control may not support the weight of the empty handling device, or may raise device at a potentially hazardous rate. Extreme care must be used until all control adjustments are complete.

### ZA Control

1. On top of the ZA manifold are two screw type flow controls. Turn “UP” and “DOWN” flow control screws clockwise until fully closed. Then turn each flow control screw counterclockwise one full turn.
2. The center screw is for hook balance adjustment. Screw head should be flush with top of manifold body.
3. Turn on air supply. Adjust supply pressure; do not exceed 100 psig (6.9 bar/690 kPa).
4. Raise load to “UP” stop.
5. Depress “DOWN” lever on ZA control pendant. Adjust “DOWN” flow control screw, by turning counterclockwise, until desired down speed is reached.
6. Depress “UP” lever on ZA control pendant. Adjust “UP” flow control screw, by turning counterclockwise, until desired speed is achieved.
7. To set hook balance point, adjust hook balance adjustment screw, by turning clockwise, until empty handling device begins to rise. Slowly adjust screw, by turning counterclockwise, until handling device stops moving.

### 2PS Control

1. Set pilot regulator screw with 1/2 inch (12 mm) of thread visible.
2. On the left side of the regulator (farthest from the balancer as the control is installed) locate trim valve screw and adjust, by turning clockwise, until closed. Turn screw counterclockwise one and a half turns.
3. Locate auxiliary flow control (closest to the balancer as the control is installed) screw and adjust, by turning screw counterclockwise, until screw head protrudes from regulator body 1/8 inch (3 mm).
4. Adjust 2PS bleed valve screw, by turning clockwise, until closed, then turn counterclockwise two turns.

5. Turn on air supply to system. Adjust supply pressure to 70 psig (4.8 bar/480 kPa) minimum, but do not exceed 100 psig (6.9 bar/690 kPa).
6. Turn on air supply to handling device.
7. Engage part with handling device.
8. Adjust pilot regulator to balance (support) handling device and part. Adjust pilot regulator screw, by turning clockwise, to increase balancing capacity. Turn screw counterclockwise to reduce balancing capacity. When balanced, equal effort will be required to raise and lower the handling device and part together.
9. Disengage part at place point.
10. Adjust bleed valve screw at 2PS valve to balance empty handling device. Turn bleed valve screw clockwise to increase balancing capacity. Turn bleed valve screw counterclockwise to decrease balancing capacity. When empty handling device is properly balanced, it will require equal effort to raise and lower.

### Interlock (Safety Circuit)

### CAUTION

- Interlock should not be adjusted until all control adjustments have been completed.

### NOTICE

- It may be necessary to actuate clamp/unclamp or vacuum/blowoff button several times to obtain correct interlock setting.
- Interlock is available only on ZA controlled handling devices.

1. With the empty handling device suspended by the balancer, adjust interlock adjustment screw, by turning counterclockwise, until 3/4 inch (38 mm) of thread is visible.
2. While cycling clamp/unclamp or vacuum/blowoff functions, turn interlock adjustment screw clockwise until both clamp/unclamp or vacuum/blowoff circuits function.
3. Cycle clamp/unclamp or vacuum/blowoff buttons several times to ensure smooth operation and that interlock valve is shifting completely.
4. Raise empty handling device to its “UP” stop. Depress “UP” lever for 3 to 4 seconds to simulate a load on the balancer.
5. Actuate clamp/unclamp or vacuum/blowoff circuits. Clamp/blowoff should not function. Air may be heard discharging to atmosphere.
6. If clamp/blowoff does function, repeat this adjustment procedure until clamp/blowoff does not open with handling device at the “UP” stop.
7. Once interlock valve is adjusted correctly, hold interlock stem with a suitable pair of pliers and tighten the 3/8 inch jam nut on interlock adjustment screw to prevent setting from changing.

## Lash-Up

To properly install load hook to wire rope you must determine the following:

1. Highest point which load must clear from floor. Refer to Dwg. MHP1358 on page 10.

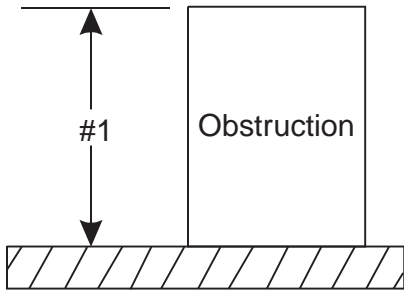

(Dwg. MHP1358)

2. Distance from hook throat to bottom of load. Refer to Dwg. MHP1896 on page 10.
3. Add dimension #1 to dimension #2, then add 3-1/2 inches (89 mm).
4. Measuring from the floor with the wire rope fully retracted, install hook using the dimension from instruction #3 to the floor.

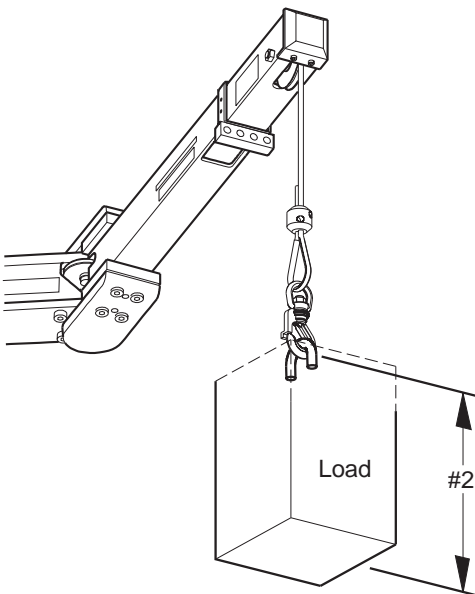

(Dwg. MHP1896)

## Yarding

### ⚠ CAUTION

- Do not operate the unit if load is not centered under wire rope. Yarding of the wire rope will cause premature wire rope failure and undue wear of unit parts.

Wire rope should not be yarded more than 10 degrees in any direction from the center line of the wire rope guide or pulley.

Excessive yarding will cause increased wear on the unit and may decrease the working life of the components.

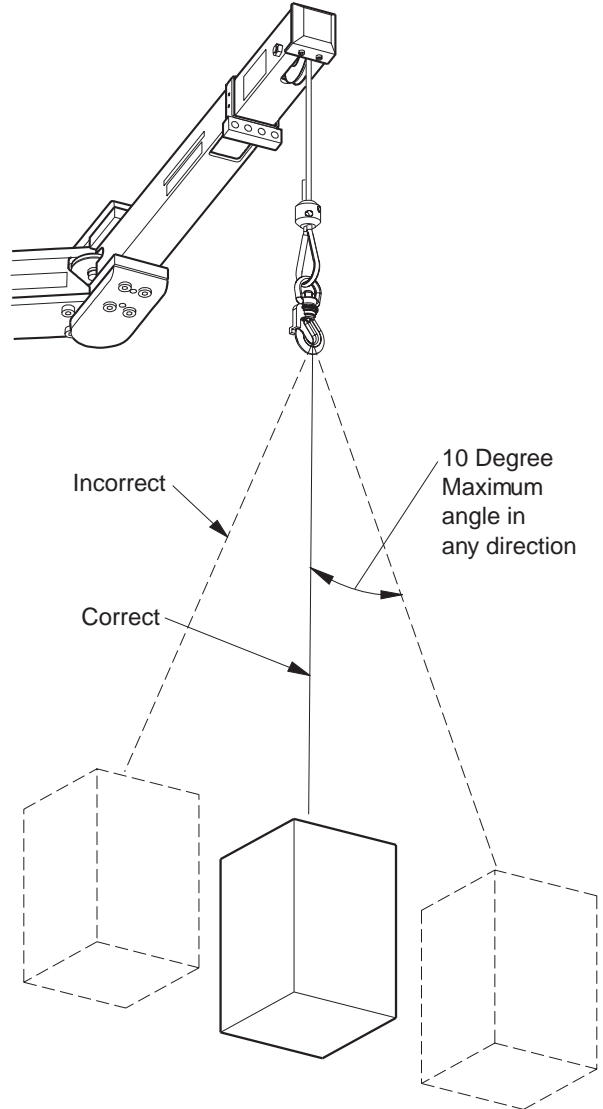

(Dwg. MHP1897)

## ⚠ WARNING

- All new, altered or modified equipment should be inspected and tested by personnel instructed in safety, operation and maintenance of this equipment to ensure safe operation at rated specifications before placing equipment in service.
- Never use a unit that inspection indicates is defective.

Frequent and periodic inspections should be performed on equipment in regular service. Frequent inspections are visual examinations performed by operators or personnel trained in safety and operation of this equipment and include observations made during routine equipment operation. Periodic inspections are thorough inspections conducted by personnel trained in the safety, operation and maintenance of this equipment. Inspection intervals depend upon the nature of the critical components of the equipment and the severity of usage.

Careful inspection on a regular basis will reveal potentially dangerous conditions while still in the early stages, allowing corrective action to be taken before the condition becomes dangerous.

Deficiencies revealed through inspection, or noted during operation, must be reported to designated personnel instructed in safety, operation and maintenance of this equipment. A determination as to whether a condition constitutes a safety hazard must be decided, and the correction of noted safety hazards accomplished and documented by written report before placing the equipment in service.

### Records and Reports

Inspection records, listing all points requiring periodic inspection should be maintained for all load bearing equipment. Written reports, based on severity of service, should be made on the condition of critical parts as a method of documenting periodic inspections. These reports should be dated, signed by the person who performed the inspection, and kept on file where they are readily available for authorized review.

### Wire Rope Reports

Records should be maintained as part of a long-range wire rope inspection program. Records should include the condition of wire rope removed from service. Accurate records will establish a relationship between visual observations noted during frequent inspections and the actual condition of wire rope as determined by periodic inspections.

### Frequent Inspections

For equipment in continuous service, frequent inspections should be made by operators at the beginning of each shift.

1. OPERATION. Check manipulator arm for full range of motion, smooth operation and ease of movement. Locate the source of any binding or rough operation and repair. Make sure all controls function properly.

2. WIRE ROPE. Lower load and visually inspect all wire rope. Inspect for wear and damage indicated by distortion of wire rope such as kinking, "birdcaging," core protrusion, main strand displacement, corrosion, broken, or cut strands. If damage is evident, do not operate unit until the discrepancies have been reviewed and inspected further by personnel instructed in the operation, safety, and maintenance of this unit.

## ⚠ WARNING

- The full extent of wire rope cannot be determined by visual inspection. At any indication of wear inspect the wire rope in accordance with instructions in "Periodic Inspection."

3. WIRE ROPE CLAMP. Inspect wire rope clamp at handling device lifting eye for tightness of clamp, security of thimble, and load hook for proper latching. Ensure wire rope free end is capped.
4. THREADED CONNECTIONS. Check all threaded connections for tightness. Tighten or replace if necessary.
5. OVERHEAD MOUNTING. If any loose or missing hardware is detected, tighten or replace.
6. TUBING. Inspect tubing and fittings for cracks, cuts or leaks. Replace if any are detected.
7. PULLEY SYSTEM. Inspect pulleys for cracks, nicks, wear or damage. Replace if necessary.
8. INTERLOCK (Safety Circuit). Test operation with no load. Raise empty handling device to the "UP" stop. With "UP" lever depressed for 3 to 4 seconds (to simulate load), actuate clamp/unclamp or vacuum/blowoff circuit. Clamp or blowoff should not function. Refer to "OPERATION" section, 'Interlock' for adjustment instructions.
9. AIR SYSTEM. Visually inspect all connections, fitting, hoses and components for indication of air leaks. Repair any leaks found.

### Periodic Inspection

Frequency of periodic inspection depends on the severity of usage:

NORMAL	HEAVY	SEVERE
yearly	semiannually	quarterly

Disassembly may be required for HEAVY or SEVERE usage. Keep accumulative written records of periodic inspections to provide a basis for continuing evaluation.

Inspect all the items in "Frequent Inspection". Also inspect the following:

1. FASTENERS. Check all rivets, split pins, capscrews and nuts. Replace if missing or tighten if loose.
2. ALL COMPONENTS. Inspect for wear, damage, deterioration, deformation and cleanliness. If external evidence indicates the need, disassemble. Check bearings, pulleys, and plates. Replace worn or damaged parts. Clean, lubricate and reassemble.

3. **WIRE ROPE.** In addition to Frequent Inspection requirements, also inspect for the following:
  - a. Build-up of dirt and corrosion. Clean with steam or a stiff wire brush to remove dirt and corrosion if necessary.
  - b. Loose or damaged end connection. Replace if loose or damaged.
  - c. Check wire rope anchor is secure in drum.
  - d. Verify wire rope diameter. Measure the diameter of the wire rope from crown-to-crown throughout the life of the wire rope. Recording of the actual diameter should only be done with the wire rope under equivalent loading and in the same operating section as accomplished during previous inspections. If the actual diameter of the wire rope has decreased more than 1/64 inch (0.4 mm) a thorough examination of the wire rope should be conducted by an experienced inspector to determine the suitability of the wire rope to remain in service. Refer to Dwg. MHP0056.

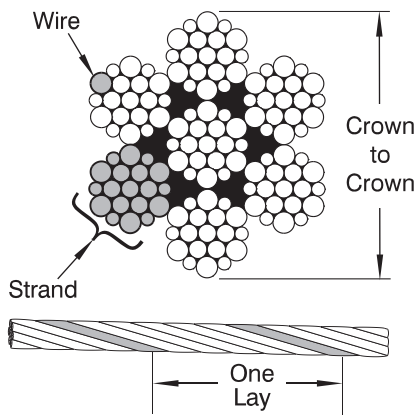

(Dwg. MHP0056)

4. **PULLEYS.** Inspect pulleys for wear or damage. Replace if necessary.
5. **PIVOT ASSEMBLY.** Inspect pivoting connections for looseness, bearing wear, and smooth operation. Repair or replace any loose or worn components.
6. **AIR SYSTEM.** Inspect valves, controls, connections for leakage and wear. Repair or replace components if leaks are found or if operation is rough. Inspect all tubing, air lines, and fittings for cuts, damage, or leakage. Repair or replace tubing and fittings as necessary.
7. **SUPPORTING STRUCTURE.** Check for distortion, wear and continued ability to support load.
8. **CARRIAGE TROLLEYS.** Check trolley assemblies for ease of movement, loose or missing hardware. Check for cracks in or damage to wheels. Repair or replace trolley and/or wheels as necessary.
9. **LABELS AND TAGS.** Check for presence and legibility of labels. Replace if damaged or missing.
10. **BALANCER.** Inspect Balancer in accordance with recommendations in Balancer Parts, Operation and Maintenance manual.
11. **CARRIAGE (optional feature).** Inspect for cracks or damage. Replace if either are found.

#### Units Not in Regular Use

1. Units which have been idle for a period of one month or more, but less than one year, should be given an inspection conforming with the requirements of "Frequent Inspection" prior to being placed into service.
2. Units which have been idle for a period of more than one year should be given an inspection conforming with the requirements of "Periodic Inspection" prior to being placed into service.
3. Standby units should be inspected at least semiannually in accordance with the requirements of "Frequent Inspection". In abnormal operating conditions, units should be inspected at shorter intervals.

## LUBRICATION

Pivot assemblies are pre-packed with grease at the factory and should not require any additional lubrication.

If after time it becomes necessary to disassemble the pivot assembly, all parts should be cleaned with a mineral spirit solution and the bearings repacked with grease. Recommended lubricant (10885) is available through **Ingersoll-Rand**.

#### Wire Rope

Follow wire rope manufacturer's instructions. At a minimum, observe the following guidelines.

1. Clean with a brush or steam to remove dirt, rock dust or other foreign material on surface of wire rope.

#### ⚠ CAUTION

• **Do not use an acid-based solvent. Only use cleaning fluids specified by wire rope manufacturer.**

2. Apply **Ingersoll-Rand LUBRI-LINK-GREEN** or ISO VG 100 (SAE 30W) oil as a wire rope lubricant.
3. Brush, drip or spray lubricant weekly, or more frequently, depending on severity of service.

## TROUBLESHOOTING

The following table is for Manipulator Arm specific problems. This section provides basic troubleshooting information. Determination of specific causes to problems are best identified by thorough inspections performed by personnel instructed in safety, operation and maintenance of this equipment. The chart below provides a brief guide to common problems, probable causes and remedies. Refer to the Balancer Service Manual for Balancer/Control specific problems.

Symptom	Possible Cause	Remedy
Hook does not balance or raise and lower.	Balancer controls may need adjustment.	Refer to Balancer manual for adjustment of controls.
	Air lines or connections may be leaking.	Check air system for leaks and repair if leaks are found.
	Air line connections incorrect.	Reconnect air lines as described in 'Connection of Air Lines' in "INSTALLATION" section.
Hook up and down is erratic.	Cable guide wheels or bearings are damaged.	Inspect guide wheels and bearing sleeves for damage or tightness. Repair or replace as required.
	Cable may be damaged.	Inspect cable and replace if damaged or worn.
Arm movement is stiff.	Swivel assembly bearings require lubrication.	Check locknut adjustment and lubricate bearings.

# INSPECTION AND MAINTENANCE REPORT

## Ingersoll Rand Manipulator Arm

<b>Model Number:</b>		<b>Date:</b>			
<b>Serial Number:</b>		<b>Inspected By:</b>			
<b>Reason for Inspection: (Check Applicable Box)</b>					
	1. Scheduled Periodic Inspection ( _____ Quarterly _____ Semiannually _____ Yearly)	<b>Operating Environment:</b>  Normal _____ Heavy _____ Severe _____			
	2. Discrepancies noted during Frequent Inspection				
	3. Discrepancies noted during Maintenance				
	4. Other: _____				
Refer to the Parts, Operation and Maintenance Manual "INSPECTION" section for general inspection criteria. Also, refer to appropriate National Standards and codes of practice. If in doubt about an existing condition, contact the nearest <b>Ingersoll-Rand</b> Distributor or the factory for technical assistance.					
COMPONENT	CONDITION		CORRECTIVE		NOTES
	Pass	Fail	Repair	Replace	
Arms					
Fasteners					
Shafts and Pulleys					
Bearings			---		
Balancer	Refer to Balancer Parts, Operation and Maintenance Manual.				
Wire Rope Guide			---		
Covers					
Controls and Hoses					
Air Manifold					
Bottom Hook	Measure hook and check for increased throat opening.				
	Damage		---		
	Hook Crack Test Method Used: Dye Penetrant _____ Magnetic Particle _____ Other: _____				
Hook Latch			---		
Wire Rope	Working length(s) maximum stretch: _____ inches/ _____ mm				
Supporting Structure					
Labels and Tags			---		
Other Components (list in NOTES section)					

This page may be photocopied and used as an Inspection/Maintenance record.

# MAINTENANCE

## ⚠ CAUTION

• Use of other than genuine Ingersoll-Rand replacement parts could result in damage to the unit and void the warranty.

## ⚠ WARNING

• Never perform maintenance on the Manipulator Arm while it is supporting a load.

• Before performing maintenance, tag controls:  
**WARNING - DO NOT OPERATE - EQUIPMENT BEING REPAIRED.**

- Only allow service personnel trained in safety and maintenance on this unit to perform maintenance.
- After performing any maintenance on the unit, adjust and test unit in specified application before returning to service.
- Turn off air supply to unit and be sure wire rope is slack before attempting any disassembly operations.

### Maintenance Intervals

The Maintenance Interval chart is based on intermittent operation of the unit eight hours each day, five days per week. If unit operation exceeds eight hours per day, or use is under HEAVY or SEVERE conditions, more frequent maintenance should be performed. Refer to 'Periodic Inspection' in the "INSPECTION" section for interval guidance.

INTERVAL	MAINTENANCE CHECK
Start of each shift  (Operator or Maintenance Personnel)	Make a thorough visual inspection of the Manipulator Arm and attached components for damage. Do not operate the unit, or components, if damaged.
	Operate the unit through the normal range of movements. Unit must operate smoothly without sticking, binding or abnormal noises.
3 months  (Maintenance Personnel)	Check operation of balancer. Refer to balancer manual for maintenance information.
Yearly  (Maintenance Personnel)	Inspect pivot assembly.
	Check all the supporting members, including the clamps, fasteners, nuts, etc. for indications of damage or wear. Repair or replace as required.

### Wire Rope Replacement

## ⚠ WARNING

• Improper routing of the wire rope can cause severe injury or death. Wire rope must run through all of the pulleys in the arm.

1. Lower load until wire rope is slack and all air pressure has been bled from balancer.
2. Turn off air supply.
3. Remove load from hook.

4. Remove hook from wire rope.
5. Remove capscrew (17) and nut (15) from upper mounting bracket of balancer.
6. Allow balancer to rotate down towards the floor. The lower mounting bolt will support weight of balancer.
7. Pull wire rope from balancer until it stops at bottom of travel.
8. Cut wire rope at the balancer.
9. Secure wire rope inside of manipulator arm until new wire rope has been installed in balancer.
10. Remove wire rope from balancer. Refer to the balancer Service Manual.
11. Install new wire rope to balancer reel.
12. Two full wraps around reel are required for balancer to function properly. Ensure second full wrap of wire rope is in the center of the cable guide opening.
13. Make a butt joint splice with old wire rope and free end of new wire rope.
14. From load end of manipulator arm, pull old wire rope from manipulator arm until new wire rope comes out of last pulley.
15. Disconnect butt splice.
16. Discard old wire rope.
17. Rotate balancer toward upper mount bracket and install capscrew (17) and nut (15).
18. Pull all slack wire rope from manipulator arm.
19. Lash hook to wire rope.
20. Apply load and turn on air supply.

### Disassembly

## NOTICE

• Air lines are connected to the balancer end cap. Use care when removing end cap.

### 700C Manipulator Arm

Refer to Dwg. MHP1567 on page 18.

1. Shut off air supply and disconnect air lines. Remove capscrews (10), washers (9), nuts (20) and manipulator arm from carriage or support.
2. Remove capscrews (11), washers (19), nuts (20) and pivot assembly (7) from rear mast (3).
3. Remove hook assembly from end of wire rope.
4. Remove wire rope, refer to 'Wire Rope Replacement.' Remove capscrews (17), nuts (15) and bushings (16) which secure the Balancer. Remove the Balancer and pull remaining wire rope from arm.
5. Remove capscrews (13) and washers (14) from connector plates (4).
6. Tap out pins (8) and (35) and separate connector plates from masts (2) or (3) and center link (1).
7. Note shim pack (22) thickness and position, then remove from center link. Tap bearing cups (24) from connector plates and bearing cones (23) from center link (1).
8. Remove capscrew (29) and separate spacer (25), thrust washers (26) and pulley (27) from center link.
9. Remove screws (42) and drive out pins (41) from cable guide (43). Remove cable guide.
10. Remove capscrew (40) and nut (45) from front mast (2). Separate bearings (38) and cable sheave (39) from front mast.
11. Loosen setscrew (44) and slide air manifold (5) from front mast (2).

## 713 Manipulator Arm

Refer to Dwg. MHP1888 on page 22.

1. Shut off air supply and disconnect air lines. Remove capscrews (10), washers (9), nuts (20) and manipulator arm from carriage or support.
2. Remove capscrews (11), washers (19), nuts (20) and pivot assembly (7) from rear mast (3).
3. Remove hook assembly from end of wire rope.
4. Remove wire rope, refer to 'Wire Rope Replacement.' Remove capscrews (17), nuts (15) and bushings (16) which secure the Balancer. Remove the Balancer and pull remaining wire rope from arm.
5. Bend lockwasher (52) tab free from locknut (51). Remove locknut, lockwasher and washer (53).
6. Separate front arm (2) from rear arm (3). Remove bearing cups (24) and bearing cones (23).
7. Remove capscrew (40) and nut (45) from front mast (2). Separate bearings (38) and cable sheave (39) from front mast.
8. Loosen setscrew (44) and slide air manifold (5) from front mast (2).

## Pivot Removal and Disassembly

Refer to Dwg. MHP1567 on page 18 and MHP1888 on page 22.

1. Remove pivot assembly (7) from arm and mounting carriage/column.
2. Reference Pivot Assembly drawings MHP1566 and MHP1873 on page 21 for component identification.
3. Bend locking tang on lockwasher (65) away from nut (66).
4. Use a 3-5/8 in. spanner with a 0.360/0.365 in. (9.1/9.3 mm) slot and remove spanner nut (66).
5. Remove lockwasher (65).
6. Remove bearing hub (64) from bearing post (61). Removal may require the use of a hammer and brass or non-marring punch to lightly tap bearing and hub from bearing post.
7. Remove bearing (62) from bearing hub (64).
8. Remove bearing (68) from bearing post (61).
9. Inspect bearing assemblies (62) and (68) for smooth rotation, binding, rust, and corrosion. None should be present or visible.

## Cleaning, Inspection and Repair

Examine disassembled components and fasteners for wear or damage. If worn or damaged, do not reuse. During reassembly all damaged and worn components should be replaced to prevent component failure which may result in injury or property damage.

It is recommended that lockwashers be discarded and replaced with new ones after each use.

Use the following procedures to clean, inspect and repair the Manipulator Arm and associated components.

## Cleaning

Thoroughly clean all Manipulator Arm components in solvent. The use of a stiff bristle brush will facilitate the removal of accumulated dirt and sediments on the columns. Wipe off each part after cleaning. Remove all old Loctite® residue.

## Inspection

All disassembled parts should be inspected to determine their fitness for continued use. Pay particular attention to the following:

1. Inspect all threaded items and replace those having damaged threads.
2. Inspect all bearings for freeness of rotation and wear. Replace bearings if rotation is rough or bearings are worn.
3. Inspect wire rope pulleys. Replace worn bushings and pulleys.
4. Inspect stop pins, stop plates and bumpers for damage. Replace if worn or deformed.
5. Inspect all pivot pins for wear. Replace pins that are scored or worn.
6. Inspect air lines for cracks, cuts and leakage.
7. Inspect air fittings for cracks, leakage and security.

## Repair

Actual repairs are limited to the removal of small burrs and other minor surface imperfections. Use a fine stone or emery cloth for this work.

1. Worn or damaged parts must be replaced. Refer to the parts section for specific replacement parts information.
2. Inspect all remaining parts for evidence of wear or damage. Replace or repair any part which is in questionable condition. The cost of the part is often minor in comparison with the cost of redoing the job.
3. When fastening components, always use Loctite® 243 on capscrew threads.

## Assembly

### 700C Manipulator Arm

Refer to Dwg. MHP1567 on page 18.

1. Install bearings (38) in cable sheave (39). Position sheave assembly in front mast (2) and secure with capscrew (40) and nut (45).
2. Install pulleys (27) in center link (1) with spacer (25), thrust washers (26) and capscrew (29).
3. Install shim sets (22) and bearing cones (23) on center link (1) pivot posts. Use positions noted during disassembly.
4. Install bearing cups (24) in connector plates (4).
5. Install connector plates (4) on center link (1) and position on rear mast (3). Secure connector plates in position with capscrews (13) and washers (14). Do not tighten capscrews.
6. Drive pins (8) into connector plates and mast until flush. Torque capscrews.
7. Repeat steps 4 and 5 to mount front mast.
8. Install cable guide (43) on front mast and secure with screws (40) and pins (41).
9. Install the Balancer on rear mast (3). Secure with capscrews (17), nuts (15) and bushings (16). Feed wire rope through mast. Ensure wire rope sits in pulley grooves. Refer to 'Wire Rope Replacement.'
10. Slide air manifold (5) onto front mast (2). Tighten setscrew (44).
11. Install pivot assembly (7) on rear mast (3) with capscrews (11), washers (19) and nuts (20). Torque to 72 ft. lbs. (98 Nm).
12. Install manipulator arm to carriage or support with capscrews (10), nuts (20) and washers (9). Connect air line.
13. Install hook assembly on end of wire rope and adjust per Lash-Up procedure in "INSTALLATION" section.



## 713 Manipulator Arm

Refer to Dwg. MHP1888 on page 22.

1. Install bearings (38) in cable sheave (39). Position sheave assembly in front mast (2) and secure with capscrew (40) and nut (45).
2. Install washer (53) and bearing cone (23) on front mast pivot post.
3. Install bearing cups (24) in rear mast (3).
4. Install front mast pivot post through bore in rear mast. Install second bearing cone (23), washer (53), lockwasher (52) and locknut (51). Ensure inside tab of lockwasher locates in slot on front mast pivot post. Torque nut to 40 ft. lbs. (54 Nm).
5. Increase torque as needed to bend one lockwasher (52) tab into locknut (51) slot.
6. Install the Balancer on front mast (2). Secure with capscrews (17), nuts (15) and bushings (16). Feed wire rope through mast.
7. Slide air manifold (5) onto front mast (2). Tighten setscrew (44).
8. Install pivot assembly (7) on rear mast (3) with capscrews (11), washers (19) and nuts (20). Torque to 72 ft. lbs. (98 Nm).
9. Install manipulator arm to carriage or support with capscrews (10), nuts (20) and washers (9). Connect air line.
10. Install hook assembly on end of wire rope and adjust per Lash-Up procedure in "INSTALLATION" section.

### Pivot Assembly and Installation

Refer to Dwgs. MHP1566 and MHP1873 on page 21.

1. Clean bearings (62) and (68) with mineral spirit solution to remove all grease. Dry bearings.
2. Re-pack bearings with grease (Zimmerman P/N 10885 – refer to "LUBRICATION" Section).
3. Install bearings to bearing hub (64) and bearing post (61).
4. Install bearing hub (64) on bearing post (61).
5. Install lockwasher (65) on bearing post (61).

## ⚠ CAUTION

• **The following torque procedure must be followed to ensure that spanner nut torque is correct, bearings have been seated, and nut will not lose torque. Failure to follow these instructions will decrease performance of the pivot and may cause damage to the arm assembly.**

6. Tighten spanner nut (66) to 200 ft.-lbs. (271 Nm)
7. Rotate pivot assembly left and right to seat bearings.
8. Torque spanner nut to 200 ft.-lbs. (271 Nm)
9. Rotate pivot assembly left and right to seat bearings.
10. Torque spanner nut to 200 ft.-lbs. (271 Nm)
11. Rotate nut clockwise until a lockwasher tang is aligned with a slot on spanner nut. Bend tang into slot.
12. Install pivot assembly on arm and mounting carriage/column.
13. Torque pivot mounting bolts to 50 ft.-lbs. (68 Nm)

## NOTICE

• **Ensure the tang on the lockwasher in the upper housing engages a slot on the pivot pin.**  
• **Tighten pivot spanner nut securely, but not so much that the lower housing assembly will not swivel.**

### Testing

Prior to initial use, all new, altered or repaired Manipulator Arms shall be tested to ensure proper operation.

1. Check Manipulator Arm movement through full operational range. Ensure movement is smooth and without binding. Ensure there are no obstructions through the operation range.
2. Ensure all guards are in place and undamaged.
3. Install handling device expected to be used. Check position and regulator adjustments.
4. Check operation of balancer. Ensure balancer responds correctly to control operation.

# MANIPULATOR ARM 700C ASSEMBLY PARTSDRAWING

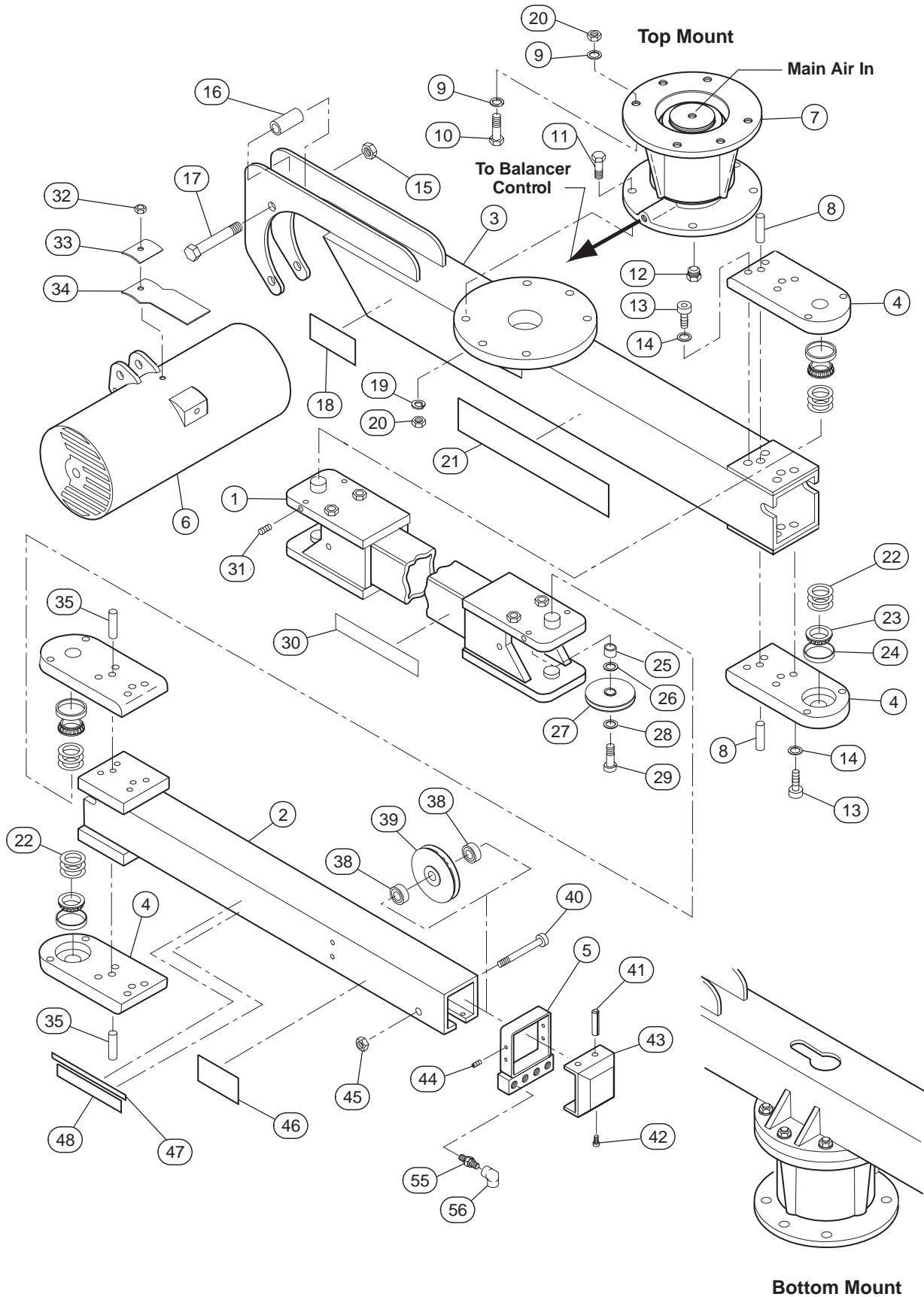

(Dwg. MHP1567)

## MANIPULATOR ARM 700C ASSEMBLY PARTS LIST

Item No.	Description of Part	Qty Total	Part Number									
			Bottom Mount				Top Mount					
			150 lb	200 lb	350 lb	500 lb	150 lb	200 lb	350 lb	500 lb		
1	Center Link, 6 ft. reach	1	41602									
	Center Link, 7ft. reach											
	Center Link, 8 ft. reach		41602		42577	41602			42577			
	Center Link, 9 ft. reach		42630		42949	42630			42949			
	Center Link, 10 ft. reach		42451		42573	42451			42573			
2	Front Mast, 6 ft. reach	1	40757		40757	42956	40757			42956		
	Front Mast, 7 ft. reach		42633		42633	42572	42633	42633		42572		
	Front Mast, 8 ft. reach						40757					
	Front Mast, 9 ft. reach											
	Front Mast, 10 ft. reach											
3	Rear Mast, 6 ft. reach	1	42422	42424	42425	42972	42421	42423	40654	42707		
	Rear Mast, 7 ft. reach		42631		42644	42657	42973	42629		42642	42655	42969
	Rear Mast, 8 ft. reach						42571					42946
	Rear Mast, 9 ft. reach											
	Rear Mast, 10 ft. reach						42631					
4	Connector Plate, 6 ft. reach	4	40623			40623	40623			40623		
	Connector Plate, 7 ft. reach											
	Connector Plate, 8 ft. reach					42676				42676	42676	
	Connector Plate, 9 ft. reach											
	Connector Plate, 10 ft. reach											
5	Air Manifold, 6 ft. reach	1	42068			42068	42068			42068		
	Air Manifold, 7 ft. reach											
	Air Manifold, 8 ft. reach					42574				42574	42574	
	Air Manifold, 9 ft. reach											
	Air Manifold, 10 ft. reach											
6	Air Balancer	1	BW015080	BW020120	BW035080	BW050080	BW015080	BW020120	BW035080	BW050080		
7	Pivot Assembly	1	40606									
	Pivot Assembly (8 to 10 ft. reach)		42410									
8	Pin	4	77063									
9	Lockwasher	6	74513									
10	Capscrew	6	72023									
11	Capscrew	12	72029									
12	Plug	1	13835									
13	Capscrew	12	72060									
14	Lockwasher	16	74532									
15	Locknut	2	17060									
16	Bushing, Suspension	2	17025									
17	Capscrew	2	17047									
18	Serial Number Plate	1	10478									
19	Lockwasher	12	74513									
20	Nut	12	75512									
21	Label – Zimmerman Logo	1	10294									
22	Shim Pack	4	40781									
23	Bearing Cone	4	65010									
24	Bearing Cup	4	65009									
25	Spacer	4	40625									
26	Thrust Washer	8	65063									
27	Pulley	4	40749									

Item No.	Description of Part	Qty Total	Part Number							
			Bottom Mount				Top Mount			
			150 lb	200 lb	350 lb	500 lb	150 lb	200 lb	350 lb	500 lb
28	Thrust Bearing	4	65008							
29	Capscrew	4	72006							
30	Label – 700C Arm	1	10284							
31	Set Screw	4	10619							
32	Nut	1	10124							
33	Cover	1	93789							
34	Plate	1	10125							
35	Pin	4	77061							
38	Bearing	2	65012							
39	Sheave, Cable	1	40689							
40	Capscrew	1	72016							
41	Pin-Spring	2	77012							
42	Screw	2	70423							
43	Cable Guide	1	40756							
44	Set Screw	2	70490							
45	Nut	1	75508							
46	Label – Warning	1	54115993							
47	Label – Ingersoll-Rand	1	10295							
48	Label – Weight Capacity	1	10402	10403	10404	10493	10402	10403	10404	10493
55	Fitting, Connector	4	Contact Factory							
56	Fitting, elbow	4	10720							

## PIVOT COLUMN MOUNT ASSEMBLY DRAWING AND PARTS LIST

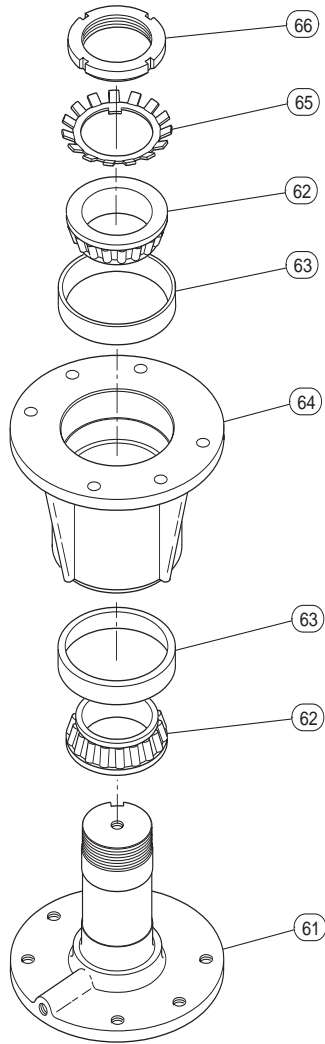

(Dwg. MHP1566)

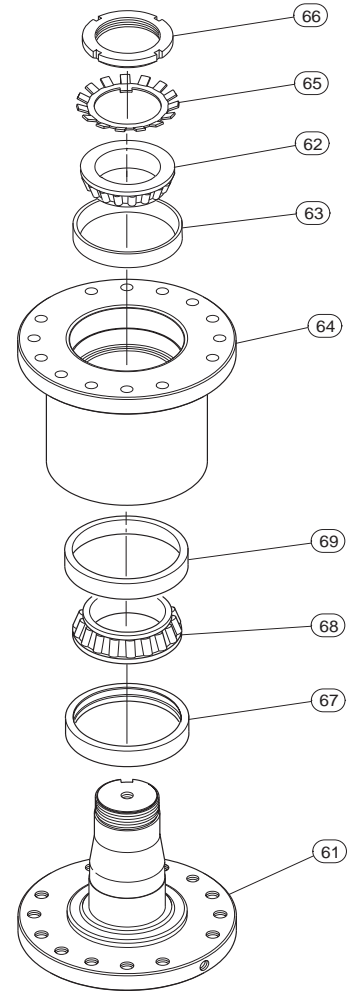

(Dwg. MHP1873)

Item No.	Description of Part	Qty Total	Part Number	
7	Pivot – Column Mount Assembly (incl’s items 61 to 66)	1	40606	—
	Pivot – Column Mount Assembly 8 to 10 ft reach (incl’s items 61 to 69)		—	42410
61	Bearing Post	1	40603	42412
62	Bearing Cone (Timken #34478 or 593)	1 (2)	65002	65112
63	Bearing Cup (Timken #34301 or 592A)	1 (2)	65001	65113
64	Bearing Hub	1	40604	42411
65	Lockwasher (Whittet Higgins #W-15)	1	74533	
66	Locknut (Whittet Higgins #AN-15)	1	75548	
67	Oil Seal (National #476842)	1	—	65114
68	Bearing Cone (Timken #47679)	1	—	65110
69	Bearing Cup (Timken #47620)	1	—	65111

# MANIPULATOR ARM 713 AND 720 ASSEMBLY PARTS DRAWING

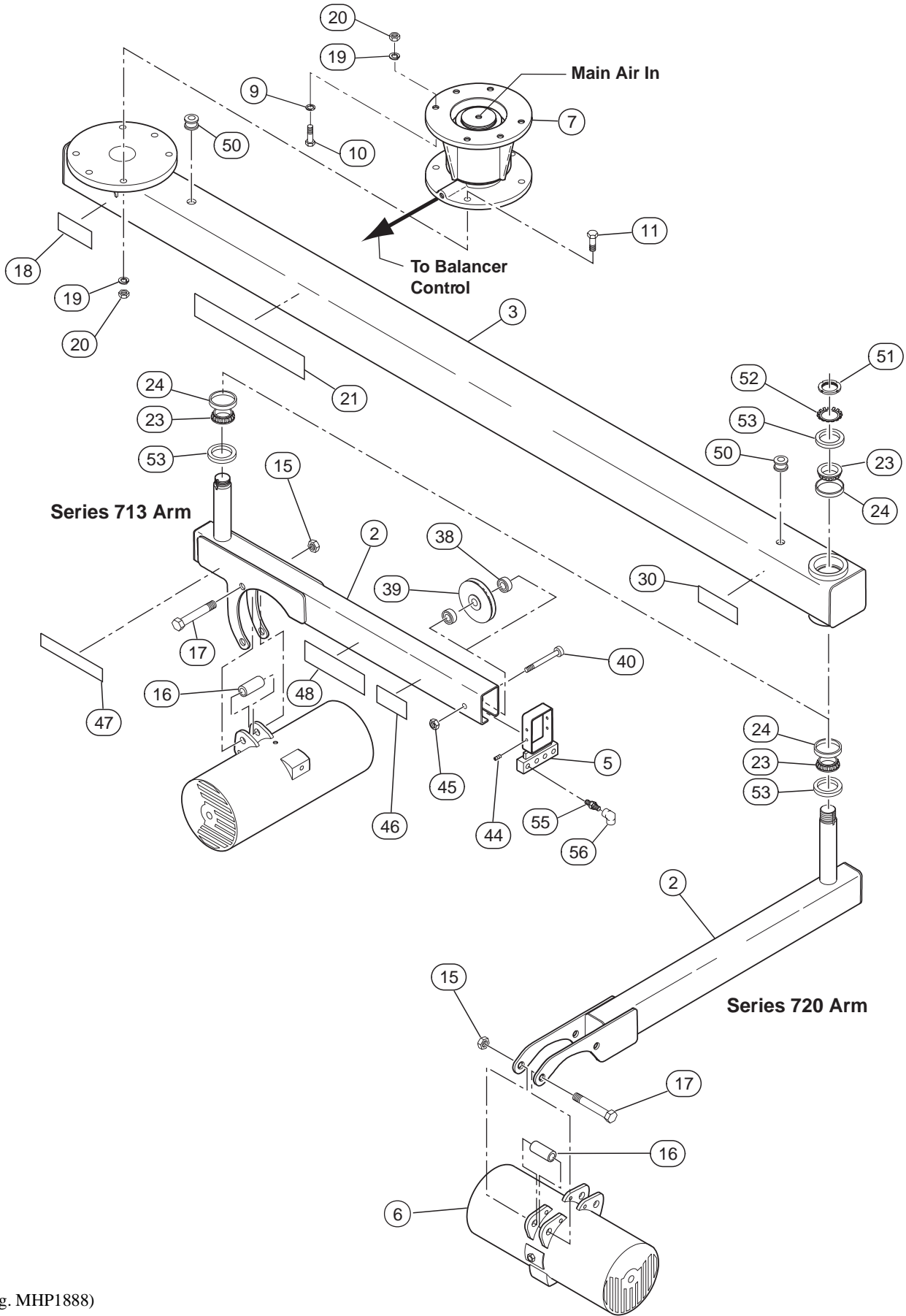

(Dwg. MHP1888)

## MANIPULATOR ARM 713 AND 720 ASSEMBLY PARTS LIST

Item No.	Description of Part	Qty Total	Part Number							
			Bottom Mount				Top Mount			
			150 lb	200 lb	350 lb	500 lb	150 lb	200 lb	350 lb	500 lb
2	Front Mast, 6 ft. reach	1	42453	42452	42835	42840	42453	42452	42835	42840
	Front Mast, 7 ft. reach		42798	42802	42836	42841	42798	42802	42836	42841
	Front Mast, 8 ft. reach		42799	42803	42560	43077	42799	42803	42560	43077
	Front Mast, 9 ft. reach		42800	42804	43066	43078	42800	42804	43066	43078
	Front Mast, 10 ft. reach		42801	42805	43067	43079	42801	42805	43067	43079
3	Rear Mast, 6 ft. reach	1	42446		42031		42446		42831	
	Rear Mast, 7 ft. reach		42794		42832		42794		42832	
	Rear Mast, 8 ft. reach		42795	42602	43074	42795	42602	43074		
	Rear Mast, 9 ft. reach		42796		43064		42796	43064	43075	
	Rear Mast, 10 ft. reach		42797		43065	43076	42797	43065	43076	
5	Air Manifold, 6 ft. reach	1	42057	42979			42057	42979		
	Air Manifold, 7 ft. reach									
	Air Manifold, 8 ft. reach									
	Air Manifold, 9 ft. reach									
	Air Manifold, 10 ft. reach									
6	Air Balancer	1	BW015080	BW020120	BW035080	BW050080	BW015080	BW020120	BW035080	BW050080
7	Pivot Assembly	1	40606							
	Pivot Assembly (8 to 10 ft. reach)		42410							
9	Lockwasher	6	74513							
10	Capscrew	6	72023							
11	Capscrew	6	72029							
15	Locknut	2	17060							
16	Bushing Suspension	2	17025							
17	Capscrew	2	17047							
18	Serial Number Plate – 713 Arm	1	10281							
19	Lockwasher	12	74513							
20	Nut	12	75512							
21	Label – Zimmerman Logo	1	10294							
23	Bearing Cone	2	65057							
24	Bearing Cup	2	65058							
30	Label – 713 Arm	1	10287							
38	Bearing	2	65012							
39	Sheave, Cable	1	40689							
40	Capscrew	1	72056							
44	Set Screw	2	70490							
45	Nut	1	75508							
46	Label – Warning	1	54115993							
47	Label – Ingersoll Rand	1	10295							
48	Label – Weight Capacity	1	10402	10403	10404	10493	10402	10403	10404	10493
50	Grommet	2	99074							
51	Locknut	1	75556							
52	Tab Washer	1	74534							
53	Washer	1	42449							
55	Fitting, Connector	4	Contact Factory							
56	Fitting, Elbow	4	10720							

Contact factory for Series 720 Arm part numbers.

# CARRIAGE ASSEMBLY DRAWING AND PARTS LIST

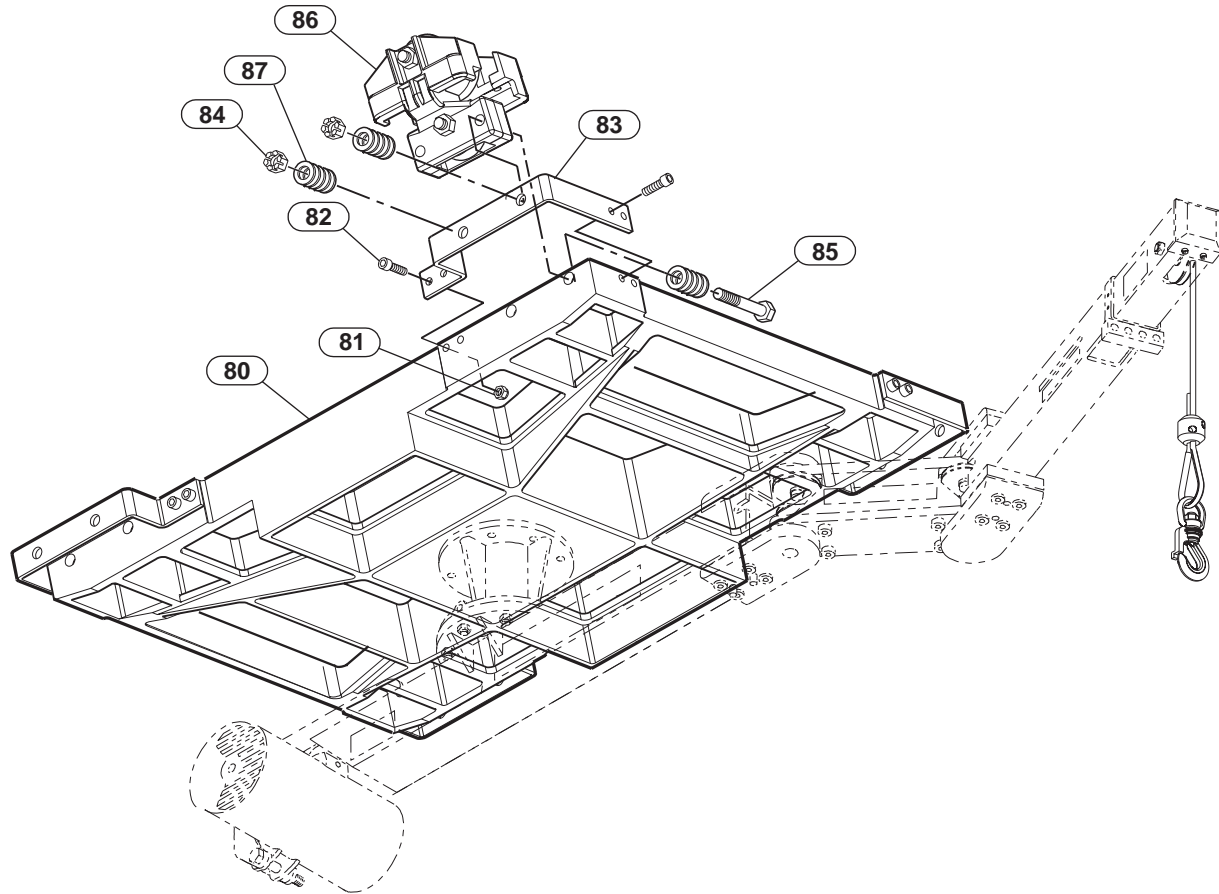

(Dwg. MHP1874)

Item No.	Description of Part	Qty Total	Part Number
80	Carriage-Basic, no trolleys	1	40710
81	Nut 3/8-16 ESNA (NE)	16	75511
82	Capscrew 3/8-16 x 1-1/2 LG. S.H.C.S.	16	71422
83	Trolley Bracket	4	40711
84	Nut 5/8-11 ESNA (NE)	8	75529
85	Capscrew 5/8-11 x 5-1/2 LG. S.H.C.S.	8	72605
86	500 lb. Capacity Trolley	4	93814
87	Spacer	As Req'd.	74514
88	Carriage assembly-T-Rail/I-beam (shown)	1	40709
	Carriage assembly-ZRA2 (reaction trolley)		30028-1
	Carriage assembly-ZRS		30028-2
	Carriage assembly-ZRA1		30028-3
	Carriage assembly-ETA-8 (reaction trolley)		30028-4
	Carriage assembly-KBK II		30028-5

**Carriage**

Lightweight ALMAG casting  
 Basic carriage weighs 60 lbs (27.3 kg)



## SERVICE NOTES

## PARTS ORDERING INFORMATION

These units are designed and constructed to provide long, trouble-free service. In time it may become necessary to order and install new parts to replace those that have been subjected to wear.

Use of other than **Ingersoll-Rand** Material Handling replacement parts may result in decreased performance, and may, at the company's option invalidate the warranty. For prompt service and genuine **Ingersoll-Rand** Material Handling parts, provide your nearest Distributor with the following:

1. Complete unit model number.
2. Part number and part description as shown in this manual.
3. Quantity required.

For your convenience and future reference it is recommended that the following information be recorded:

**Model Number** \_\_\_\_\_

**Serial Number** \_\_\_\_\_

**Date Purchased** \_\_\_\_\_

### Return Goods Policy

**Ingersoll-Rand** will not accept any returned goods for warranty or service work unless prior arrangements have been made and written authorization has been provided from the location where the goods were purchased.

### NOTICE

**• Continuing improvement and advancement of design may produce changes to this unit which are not included in this manual. Manuals are periodically revised to incorporate changes. Always check manual edition number on front cover for latest issue.**

### Disposal

When the life of the unit has expired, it is recommended that the air motor be disassembled, degreased and parts separated as to materials so that they may be recycled.

For additional information contact:

**Ingersoll-Rand  
Zimmerman Handling Systems**  
29555 Stephenson Highway  
Madison Heights, MI  
48071-2387  
Phone: (248) 398-6200  
Fax: (248) 298-1374

or

**Ingersoll-Rand** Material Handling  
Douai Operations  
111, avenue Roger Salengro  
59450 Sin Le Noble, France  
Phone: (33) 3-27-93-08-08  
Fax: (33) 3-27-93-08-00

For additional information on the following products order the publication by the referenced Part/Document Number listed:

Publication	Part/Document Number	Publication	Part/Document Number
Z-Balancer	ZBSM0195	Z-Rail System	MHD56159
Rotary Action Handler	MHD56163	Valu-Trak Rail System	MHD56161

## LIMITED WARRANTY

**Ingersoll-Rand Company (I-R)** warrants to the original user its Products to be free of defects in material and workmanship for a period of one year from the date of purchase. **I-R** will repair, without cost, any Product found to be defective, including parts and labor charges, or at its option, will replace such Products or refund the purchase price less a reasonable allowance for depreciation, in exchange for the Product. Repairs or replacements are warranted for the remainder of the original warranty period.

If any Product proves defective within its original one year warranty period, it should be returned to any Authorized **I-R** Material Handling Service Distributor, transportation prepaid with proof of purchase or warranty card.

This warranty does not apply to Products which **I-R** has determined to have been misused or abused, improperly maintained by the user, or where the malfunction or defect can be attributed to the use of non-genuine **I-R** parts.

**I-R makes no other warranty, and all implied warranties including any warranty of merchantability or fitness for a particular purpose are limited to the duration of the expressed warranty period as set forth above. I-R's maximum liability is limited to the purchase price of the Product and in no event shall I-R be liable for any consequential, indirect, incidental, or special damages of any nature rising from the sale or use of the Product, whether based on contract, tort, or otherwise.**

Note: Some states do not allow limitations on incidental or consequential damages or how long an implied warranty lasts so that the above limitations may not apply to you.

This warranty gives you specific legal rights and you may also have other rights which may vary from state to state.

## IMPORTANT NOTICE

It is our policy to promote safe delivery of all orders.

This shipment has been thoroughly checked, packed and inspected before leaving our plant and receipt for it in good condition has been received from the carrier. Any loss or damage which occurs to this shipment while en route is not due to any action or conduct of the manufacturer.

### **Visible Loss or Damage**

If any of the goods called for on the bill of lading or express receipt are damaged or the quantity is short, do not accept them until the freight or express agent makes an appropriate notation on your freight bill or express receipt.

### **Concealed Loss or Damage**

When a shipment has been delivered to you in apparent good condition, but upon opening the crate or container, loss or damage

has taken place while in transit, notify the carrier's agent immediately.

### **Damage Claims**

You must file claims for damage with the carrier. It is the transportation company's responsibility to reimburse you for repair or replacement of goods damaged in shipment. Claims for loss or damage in shipment must not be deducted from the **Ingersoll-Rand** invoice, nor should payment of **Ingersoll-Rand** invoice be withheld awaiting adjustment of such claims as the carrier guarantees safe delivery.

You may return products damaged in shipment to us for repair, which services will be for your account and form your basis for claim against the carrier.

## United States Office Locations

### Technical Support

**Ingersoll-Rand  
Zimmerman Handling  
Systems**  
29555 Stephenson Highway  
Madison Heights, MI  
48071-2387  
Phone: (248) 398-6200  
Fax: (248) 398-1374

### For Order Entry, Order Status

**Ingersoll-Rand  
Distribution Center**  
P.O. Box 618  
510 Hester Drive  
White House, TN 37188  
Phone: (615) 672-0321  
Fax: (615) 672-0801

### Web Site:

[www.ingersoll-rand.com](http://www.ingersoll-rand.com)

### Regional Sales Offices

**Chicago, IL**  
888 Industrial Drive  
Elmhurst, IL 60126  
Phone: (630) 530-3800  
Fax: (630) 530-3891

**Detroit, MI**  
1872 Enterprise Drive  
Rochester Hills, MI 48309  
Phone: (248) 293-5700  
Fax: (248) 293-5800

**Houston, TX**  
450 Gears Road  
Suite 210  
Houston, TX 77067-4516  
Phone: (281) 872-6800  
Fax: (281) 872-6807

**Los Angeles, CA**  
11909 E. Telegraph Road  
Santa Fe Springs, CA 90670  
Phone: (562) 948-4189  
Fax: (562) 948-1828

**Philadelphia, PA**  
P.O. Box 425  
900 E. 8th Avenue, Suite 103  
King of Prussia, PA 19406  
Phone: (610) 337-5930  
Fax: (610) 337-5912

## International Office Locations

Offices and distributors in principal cities throughout the world. Contact the nearest **Ingersoll-Rand** office for the name and address of the distributor in your country or write/fax to:

**Ingersoll-Rand  
Zimmerman Handling  
Systems**  
29555 Stephenson Highway  
Madison Heights, MI  
48071-2387  
Phone: (248) 398-6200  
Fax: (248) 398-1374

**Canada  
National Sales Office  
Regional Warehouse  
Toronto, Ontario**  
51 Worcester Road  
Rexdale, Ontario  
M9W 4K2  
Phone: (416) 213-4500  
Fax: (416) 213-4510  
**Order Desk**  
Fax: (416) 213-4506

**Regional Sales Offices  
Edmonton, Alberta**  
1430 Weber Center  
5555 Calgary Trail NW  
Edmonton, Alberta  
T6H 5P9  
Phone: (780) 438-5039  
Fax: (780) 437-3145

**Montreal, Quebec**  
3501 St. Charles Blvd.  
Kirkland, Quebec  
H9H 4S3  
Phone: (514) 695-9040  
Fax: (514) 695-0963

**British Columbia**  
1200 Cliveden Avenue  
Delta, British Columbia  
V3M 6G4  
Phone: (604) 523-0803  
Fax: (604) 523-0801

**Latin America Operations  
Ingersoll-Rand  
Production Equipment Group**  
730 NW 107th Avenue  
Suite 300, Miami, FL  
33172-3107  
Phone: (305) 559-0500  
Fax: (305) 222-0864

**Europe, Middle East and  
Africa  
Ingersoll-Rand  
Material Handling  
Douai Operations**  
111, avenue Roger Salengro  
59450 Sin Le Noble, France  
Phone: (33) 3-27-93-08-08  
Fax: (33) 3-27-93-08-00

**Asia Pacific Operations  
Ingersoll-Rand Asia Pacific Inc.**  
Suite 1201-3, 12/F  
Central Plaza  
18 Harbour Road  
Wanchai, Hong Kong  
Phone: (852) 2527 0183  
Fax: (852) 2529 5976

**Russia  
Ingersoll-Rand**  
Kuznetsky Most 21/5  
Entrance 3  
Moscow 103895 Russia  
Phone: 7-501-923-9134  
Fax: 7-501-924-4625