

# PARTS, OPERATION AND MAINTENANCE MANUAL

## M-SERIES

### LOAD POSITIONER

#### MW005060

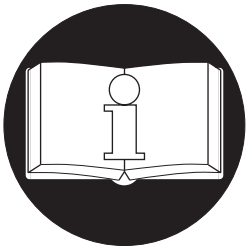
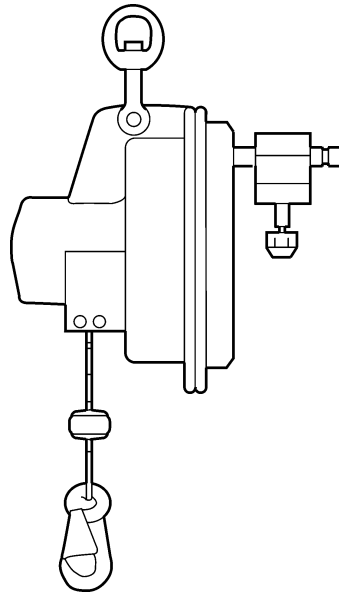

**READ THIS MANUAL BEFORE USING THESE PRODUCTS.** This manual contains important safety, installation, operation and maintenance information. Make this manual available to all persons responsible for the operation, installation and maintenance of these products.

#### **⚠ WARNING**

**Do not use this unit for lifting, supporting, or transporting people or lifting or supporting loads over people.**

**Always operate, inspect and maintain this unit in accordance with applicable safety codes and regulations.**

## SAFETY INFORMATION

This manual provides important information for all personnel involved with the safe installation, operation and proper maintenance of this product. Even if you feel you are familiar with this or similar equipment, you should read this manual before operating the unit.

### Danger, Warning, Caution and Notice

Throughout this manual there are steps and procedures which, if not followed, may result in an injury. The following signal words are used to identify the level of potential hazard.

#### DANGER

Danger is used to indicate the presence of a hazard which **will** cause **severe** injury, death, or substantial property damage if the warning is ignored.

#### WARNING

Warning is used to indicate the presence of a hazard which **can** cause **severe** injury, death, or substantial property damage if the warning is ignored.

#### CAUTION

Caution is used to indicate the presence of a hazard which **will** or **can** cause injury or property damage if the warning is ignored.

#### NOTICE

Notice is used to notify people of installation, operation, or maintenance information which is important but not hazard-related.

### Safety Summary

#### WARNING

- Do not use this unit or attached equipment for lifting, supporting, or transporting people or lifting or supporting loads over people.
- The supporting structures and load-attaching devices used in conjunction with these units must provide a safety factor of at least three times the rated capacity of the unit. This is the customer's responsibility. If in doubt, consult a registered structural engineer.

#### NOTICE

- Lifting equipment is subject to different regulations in each country. These regulations may not be specified in this manual.

The National Safety Council, Accident Prevention Manual for Industrial Operations, Eighth Edition and other recognized safety sources make a common point: Employees who work near

suspended loads or assist in hooking on or arranging a load should be instructed to keep out from under the load. From a safety standpoint, one factor is paramount: conduct all lifting operations in such a manner that if there were an equipment failure, no personnel would be injured. This means keep out from under a raised load and keep out of the travel path of any load.

The Occupational Safety and Health Act of 1970 generally places the burden of compliance with the user, not the manufacturer. Many OSHA requirements are not concerned or connected with the manufactured product but are, rather, associated with the final installation. It is the owner's and user's responsibility to determine the suitability of a product for any particular use. It is recommended that all applicable industry, trade association, federal, state, and local regulations be checked. Read all operating instructions and warnings before operation.

**Rigging:** It is the responsibility of the operator to exercise caution, use common sense and be familiar with proper rigging techniques. See ASME B30.9 for rigging information, American National Standards Institute, 1430 Broadway, New York, NY 10018.

This manual has been produced by **Ingersoll-Rand** to provide dealers, mechanics, operators and company personnel with the information required to install, operate, maintain and repair the products described herein. It is extremely important that mechanics and operators be familiar with the servicing procedures of these products, or like or similar products, and are physically capable of conducting the procedures. These personnel shall have a general working knowledge that includes:

1. Proper and safe use and application of mechanics common hands tools as well as special **Ingersoll-Rand** recommended tools.
2. Safety procedures, precautions and work habits established by accepted industry standards.

**Ingersoll-Rand** cannot know of, or provide all the procedures by which product operations or repairs may be conducted and the hazards and/or results of each method. If operation or maintenance procedures not specifically recommended by the manufacturer are conducted, it must be ensured that product safety is not endangered by the actions taken. If unsure of an operation or maintenance procedure or step, personnel should place the product in a safe condition and contact supervisors and/or the factory for technical assistance.

Safe installation and operation of **Ingersoll-Rand** units depend on you reading all instructions before starting work on the unit.

#### CAUTION

- Clean, dry air must be used at all times when operating these units.

## SAFE OPERATING INSTRUCTIONS

The following warnings and operating instructions have been adapted in part from American National (Safety) Standards and are intended to avoid unsafe operating practices which might lead to injury or property damage.

**Ingersoll-Rand** recognizes that most companies who are using these units have a safety program in force at their facility. In the event that some conflict exists between a rule set forth in this publication and a similar rule already set by an individual company, the more stringent of the two should take precedence.

Safe Operating Instructions are provided to make an operator aware of dangerous practices to avoid and are not necessarily limited to the following list. Refer to specific sections in the manual for additional safety information.

1. Only allow personnel trained in safety and operation of this unit to operate this product.
2. Only operate the unit if you are physically fit to do so.
3. When a **“DO NOT OPERATE”** sign is placed on the unit, or controls, do not operate the unit until the sign has been removed by designated personnel.
4. Do not use the unit if hook latch has been sprung or broken.
5. Before each shift, check the unit for wear and damage. Never use a unit that inspection indicates is worn or damaged.
6. Never lift a load greater than the rated capacity of the unit. See capacity labels attached to the unit.
7. Do not use more than one hook on a single load.
8. Never place your hand inside the throat area of a hook.
9. Never use the wire rope as a sling.
10. Only operate the unit when the wire rope is centered over the load. Do not “side pull” or “yard”.
11. Never operate the unit with twisted, kinked or damaged wire rope.
12. Do not force hook into place by hammering.
13. Be certain the load is properly seated in the saddle of the hook.
14. Do not support the load on the tip of the hook.
15. Never run the wire rope over a sharp edge.
16. Pay attention to the load at all times when operating the unit.
17. Make sure everyone is clear of the load path. Do not lift a load over people.
18. Never use the unit for lifting or lowering people, and never allow anyone to stand on a suspended load.
19. Do not swing a suspended load.
20. Never weld or cut a load suspended by the unit.
21. Ensure safety Wire Rope is installed (where required).
22. Do not operate the unit if wire rope is jumping, excessive noise, jamming, overloading, or binding occurs.
23. Shut off air supply before performing any maintenance.
24. Avoid collision or bumping of the units.

## OPERATION

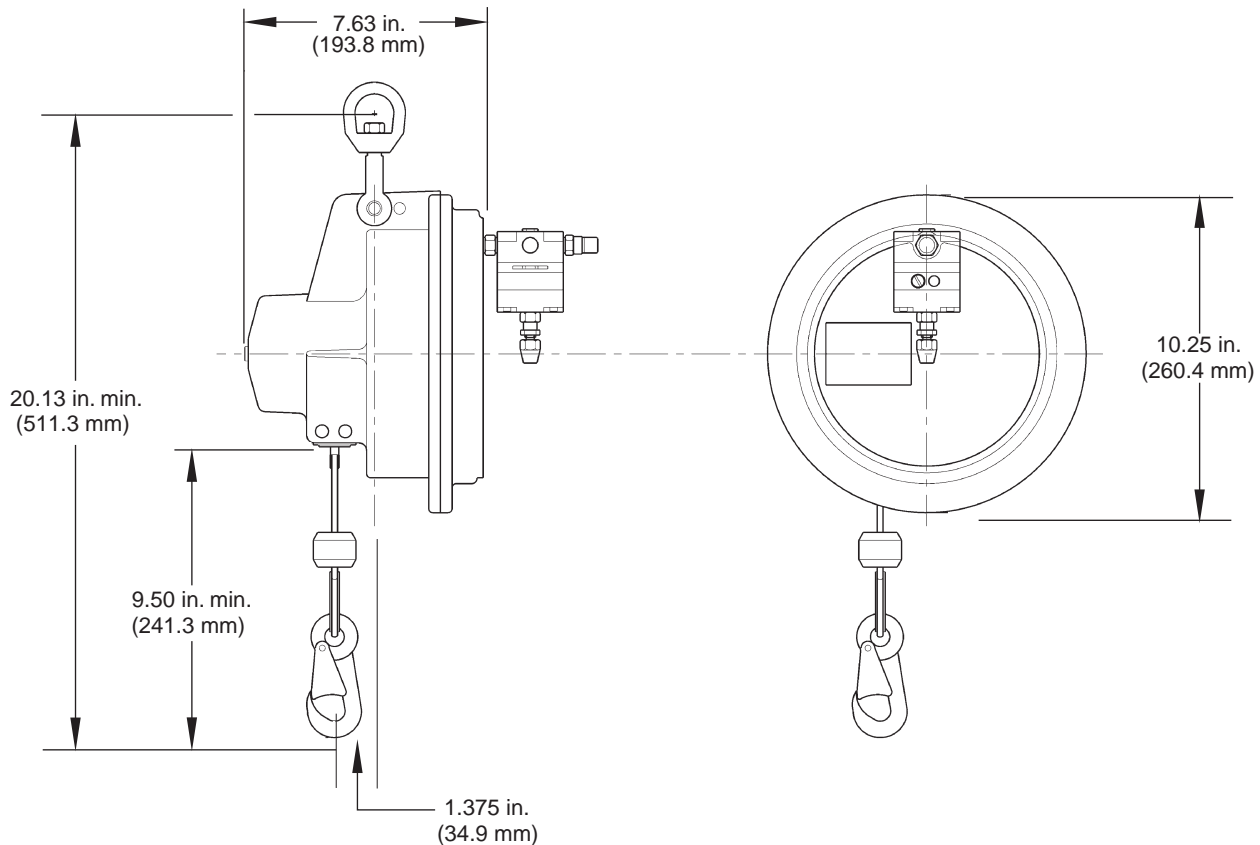

(Dwg. MHP1256)

### Description of Operation

The 50 lb. unit utilizes a tapered end fixed ball screw, held in position by the center bolt in the housing assembly. The ball nut is threaded onto the ball screw. The reel is secured to the ball nut with a setscrew. A thrust bearing is pressed into the piston on the

reel side. Air enters the unit, the diaphragm is inflated and pushes the piston. The piston and thrust bearing assembly force the reel to rotate along the ball screw and wind the wire rope into the unit. When the wire rope is pulled to lower the load the self relieving regulator allows the pressure to be released from the unit and the load to lower.

## INSTALLATION

Prior to installing the unit, carefully inspect it for possible shipping damage. The units are supplied fully lubricated from the factory.

### CAUTION

- Owners and users are advised to examine specific, local or other regulations, including American National Standards Institute and/or OSHA Regulations which may apply to a particular type of use of this product before installing or putting the unit into use.
- A falling load can cause injury or death. Before installing, read "SAFETY INFORMATION".

### Load Positioner Tool Balancer

Make certain the unit is properly installed. A little extra time and effort in so doing can contribute a lot toward preventing accidents and helping you get the best service possible.

Always make certain the supporting member from which the unit is suspended is strong enough to support the weight of the unit plus the weight of a maximum rated load plus a generous factor of at least 300% of the combined weights.

If the unit is suspended by a top hook, the supporting member should rest completely within the saddle of the hook and be centered directly above the hook shank. Do not use a supporting member that tilts the unit to one side or the other.

### Hook Mounted Load Positioner Installation

Place hook over mounting structure. Make sure hook latch is engaged.

### WARNING

- To avoid an unbalanced load which may damage the trolley, the unit must be centered under the trolley.

### Rail Mounted Load Positioner Installation

For proper and safe installation of the unit on a rail system refer to Installation and Maintenance Manual for that rail system.

### Air System

The supply air must be clean and free from water and water vapor. 100 psi (6.9 bar/690 kPa) at the unit is required to provide rated capacity. Do not exceed 100 psi.

### ⚠ WARNING

• Do not exceed 100 psi (6.9 bar/690 kPa) inlet pressure. Do not use a lubricator of any kind. Oil will damage internal components.

### Air Lines

The inside diameter of the unit air supply lines must not be smaller than 3/8 in. (10 mm) based on a maximum of 100 ft. (30 m) between the air supply and the unit. Contact the factory for recommended air line sizes for distances greater than 100 ft. (30 m). Before making final connections, all air supply lines should be purged before connecting to unit inlet. Supply lines should be as short and straight as installation conditions will permit. Long transmission lines and excessive use of fittings, elbows, tees, globe valves, etc. cause a reduction in pressure due to restrictions and surface friction in the lines. If quick-disconnect fittings are used at the inlet of the unit, they must have at least a 3/16 in. (10 mm) air passage. Use of smaller fittings will reduce performance.

### Air Line Filter

It is recommended that an air line strainer/filter be installed as close as practical to the unit air inlet port. The strainer/filter should provide 5 micron filtration and include a moisture trap. Clean the strainer/filter monthly to maintain its operating efficiency.

To maintain dry air, the frequency for draining the filter should also be based on the condition of the air supply. We suggest the filter be drained weekly at first. Depending on air supply condition, a proper filter drain schedule should be established.

### Moisture in Air Lines

Moisture that reaches the unit through the supply lines is the chief factor in determining the length of time between service overhauls. Moisture traps can help to eliminate moisture. Other methods, such as an air receiver which collects moisture before it reaches the unit controls or an aftercooler at the compressor that cools the air prior to distribution through the supply lines, are also helpful.

### Single Balance (S) Control

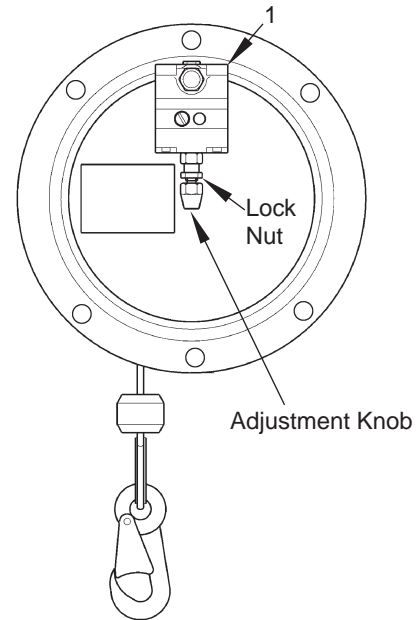

(Dwg. MHP1257)

Item No.	Description of Part	Qty. Total	Part No.
1	Regulator Assembly (S) Control Kit	1	13825

### Regulator Installation

The regulator is supplied with a hex nipple and a check valve. The hex nipple should be threaded into the hole on the cover as shown in Dwg. MHP1257. Connect the air supply to the check valve.

### NOTICE

• The arrow on the check valve must be pointing toward the unit. If installed backwards the unit will not function.

### Operational Adjustments

### ⚠ WARNING

• Prior to performing operational adjustments or servicing make sure air supply is off and wire rope is slack.

1. Turn adjustment knob counter-clockwise until it stops.
2. Attach load to the end of the wire rope.
3. Turn on air supply.
4. By turning the regulator adjustment knob clockwise, you increase the balancing capacity.
5. By turning, the regulator adjustment knob counter-clockwise, you decrease the balancing capacity.
6. To properly adjust the unit, turn the adjustment knob so that it takes equal effort to move the load up and down.
7. Tighten lock nut on regulator stem to ensure adjustment is maintained.

(S) Control Regulator

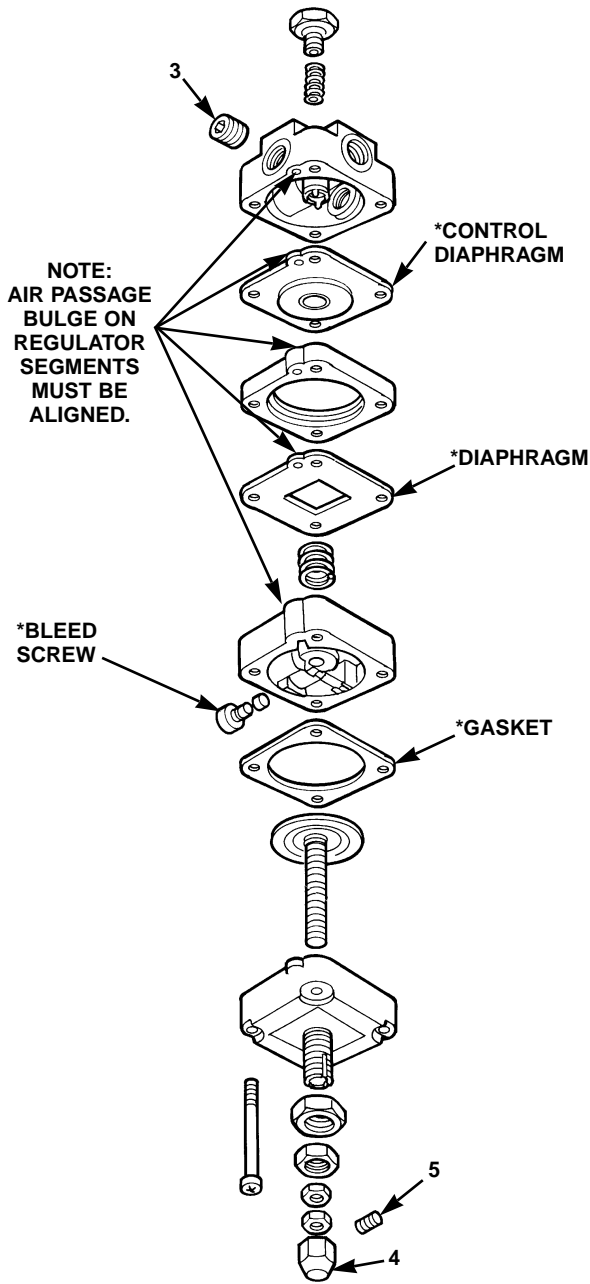

\* Suggested Spare Parts Available in Kit # 13850

(Dwg. MHP1258)

Regulator Assembly

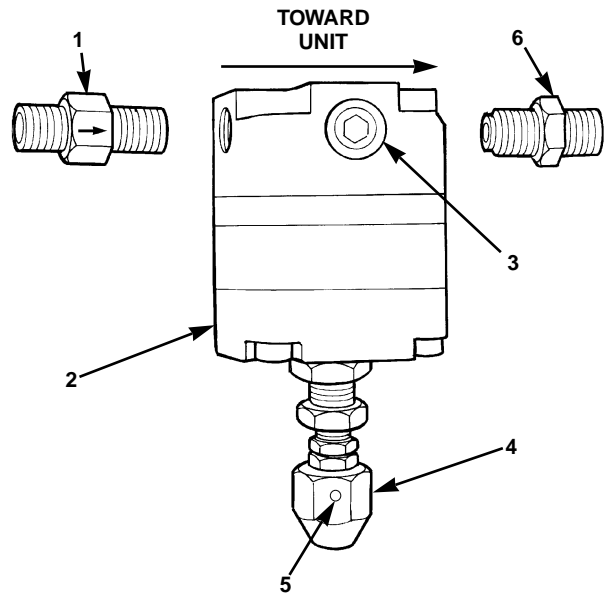

(Dwg. MHP1259)

Item No.	Description of Part	Qty. Total	Part Number
---	Regulator Assembly (Includes items 1 through 6)	1	13825
1	Check Valve	1	13270
2	Regulator	1	13830
3	Plug	2	10764
4	Control knob	1	13832
5	Soc Set Screw	1	13833
6	Hex Nipple	1	13840

## TROUBLESHOOTING

### ⚠ CAUTION

- Before doing any disassembly, lower load and turn control knob (counter-clockwise) until wire rope is slack. Prior to performing additional adjustments or servicing make sure air supply is off.

SYMPTOM	POSSIBLE CAUSE	REMEDY
Unit will not lift load.  <i>Notice: Make sure load does not exceed capacity of unit.</i>	Check valve installed backwards.	Install check valve properly, arrow toward regulator.
	Regulator adjustment set low.	Turn adjustment clockwise until load rises.
	Insufficient air pressure.	Increase pressure to 100 psi. (6.9 bar/690 kPa)
	Excessive leakage around cover.	Check for damaged diaphragm.
Load rises but is hard to pull down	Regulator adjustment set too high.	Back off adjustment (counterclockwise) until load is balanced.
	Exhaust hole in regulator bleed screw plugged.	Clean exhaust hole using fine wire, or replace bleed screw.
Air constantly blowing out of exhaust ports on regulator.	Ruptured diaphragm in regulator.	Replace diaphragm.
Erratic, jerky operation.	Fluctuating air supply pressure.	Stabilize air pressure. Refer to air supply information.
	Dirt or oil clogging inlet valve or bleed screw orifice.	Clean thoroughly.

## PREVENTIVE MAINTENANCE CHECKS AND SERVICE

### ⚠ CAUTION

- Clean, dry air must be used at all times when operating these units.

#### Preventive Maintenance

These preventive maintenance recommendations are designed to prevent unexpected breakdowns and problems through periodic inspection and maintenance. Maintenance intervals should be based on frequency of usage and operating environment. Frequent usage, or dirty operating conditions require more frequent servicing. **A clean, dry air supply will help keep the equipment functioning properly.** On page 9 you will find a load positioner Inspection and Maintenance Report. Using this report will aid in tracking component failures or faults. We recommend the use of this report as a preventive maintenance tool.

#### Wire Rope and Load Hooks

Wire rope, load hooks, thimbles and clamps should be inspected on a daily basis. Time intervals should be based on the frequency of usage and in accordance with standard wire rope manufacturers specifications. Refer to "Inspection and Maintenance Schedule".

#### Air Supply

**Be sure that the air supply is free of rust, dirt, water and oil.** Use of a good air filter and in line regulator is highly recommended. A pressure of 100 psi (6.9 bar/690 kPa) is required to operate the unit at its maximum capacity. Lower pressure reduces unit capacity accordingly. **Do not use an air in-line oiler. Oil will damage the unit and controls.**

#### Units Not in Regular Use

1. Units which have been idle for a period of one month or more, but less than one year, should be given an inspection conforming with the requirements of "Frequent Inspection" prior to being placed into service.
2. Units which have been idle for a period of more than one year should be given an inspection conforming with the requirements of "Periodic Inspection" prior to being placed into service.
3. Standby units should be inspected at least semi-annually in accordance with the requirements of "Frequent Inspection." In abnormal operating conditions units should be inspected at shorter intervals.

## INSPECTION AND MAINTENANCE SCHEDULE

Component	Inspection	Criteria for Operation	Daily (1st Operation of Shift)	Frequent (Less than 6 months/semi annual)	Periodic (More than 6 months/annual)
Wire Rope	Kinks	No visible kinks on entire length	X	X	X
	Fraying	No visible fraying on entire length	X	X	X
	Bird caging	No visible separations on entire length	X	X	X
Clamps	Tightness	Clamp will not slide on wire rope, or loose	X	X Torque check clamps at 7.5 ft. lbs	X Torque check clamps at 7.5 ft. lbs
	Cracks	No visible cracks	X	X	X
Load Hook	Cracks	No visible cracks	X		X
	Swivel	Smooth operation and free rotation	X		
	Hook Latch	Positive locking of latch	X	X	X
Suspension Kit	Hardware	No loose or missing hardware	X	X	X
	Trolley Body	Aluminum – no visible cracks. Steel – no visible broken welds	X		X
	Trolley Wheels	Smooth operation with no binding	X		X
	Hook Mount (Optional)	Positive locking of latch	X		X
	Safety Cable (Optional)	No loose clamps or broken wires	X	X Torque check clamps at 7.5 ft. lbs	X Torque check clamps at 7.5 ft. lbs
Load Positioner	Smooth operation	No binding or resistance in motion	X	X	X
	Lubrication	Ball screw and thrust bearing for grease			X
	Wear	Internal parts for excessive wear Refer to “Unit Cleaning and Inspection”			X



# INSPECTION AND MAINTENANCE REPORT

## Ingersoll Rand

<b>Model Number:</b>			<b>Date:</b>		
<b>Serial Number:</b>			<b>Inspected by:</b>		
<b>Reason for Inspection: (Check Applicable Box)</b>					
	1. Scheduled Periodic Inspection ( ___ Semiannually___ Yearly)	Operating Environment:  Normal ___ Heavy ___ Severe ___			
	2. Discrepancies noted during Frequent Inspection				
	3. Discrepancies noted during maintenance				
	4. Other: _____				
Refer to the Parts, Operation and Maintenance Manual "INSPECTION" section for general inspection criteria. Also, refer to appropriate National Standards and Codes of practice. If in doubt about an existing condition contact the nearest <b>Ingersoll-Rand</b> Distributor or the factory for technical assistance.					
COMPONENT	CONDITION		CORRECTIVE		NOTES
	Pass	Fail	Repair	Replace	
Fasteners					
Shafts					
Bearings			---		
Reel					
Wire Rope Guide			---		
Covers					
Controls					
Hooks			---		
Top	Measure hook and check for increased throat opening.				
	Damage			---	
	Hook Crack Test Method Used: Dye Penetrant ___ Magnetic Particle ___ Other: _____				
Bottom	Measure hook and check for increased throat opening.				
	Damage			---	
	Hook Crack Test Method Used: Dye Penetrant ___ Magnetic Particle ___ Other: _____				
Hook Latch			---		
Wire Rope					
Working length(s) maximum stretch: _____ inches / _____ mm					
Supporting Structure					
Rail System					Refer to Rail System Manual
Labels and Tags			---		
Other Components (list in NOTES section)					

This page may be photocopied and used as an Inspection/Maintenance record.

# LOAD HOOK LASH-UP AND YARDING

## Lash-Up

To properly install the load hook to wire rope you must determine the following:

1. Highest point which load must clear from floor. (Refer to Dwg. MHP1358).
2. Distance from hook throat to bottom of load. (Refer to Dwg. MHP1260).
3. Add number 1 dimension to number 2 dimension, then add 3-1/2 inches (89 mm).
4. Measuring from the floor with the wire rope fully retracted, install hook using the dimension from number 3 to the floor.

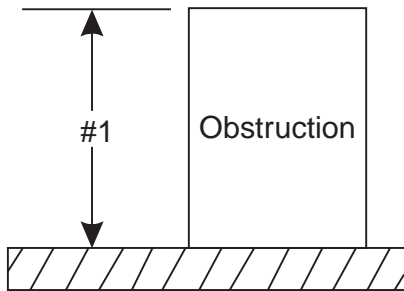

(Dwg. MHP1358)

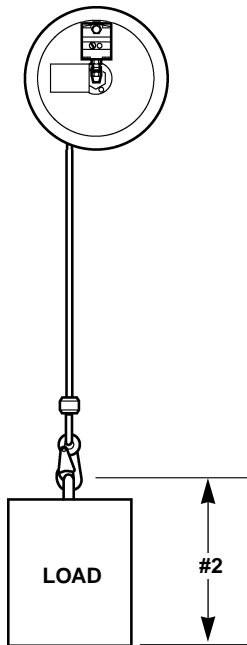

(Dwg. MHP1260)

## ⚠ CAUTION

• Do not operate the unit if load is not centered under wire rope. Yarding of the wire rope will cause premature wire rope failure and undue wear of internal unit parts and may void warranty.

## Yarding

The wire rope should not be yarded more than 10 degrees from the center line of the wire rope guide.

Excessive yarding will cause increased wear on the unit and decrease the working life of the components.

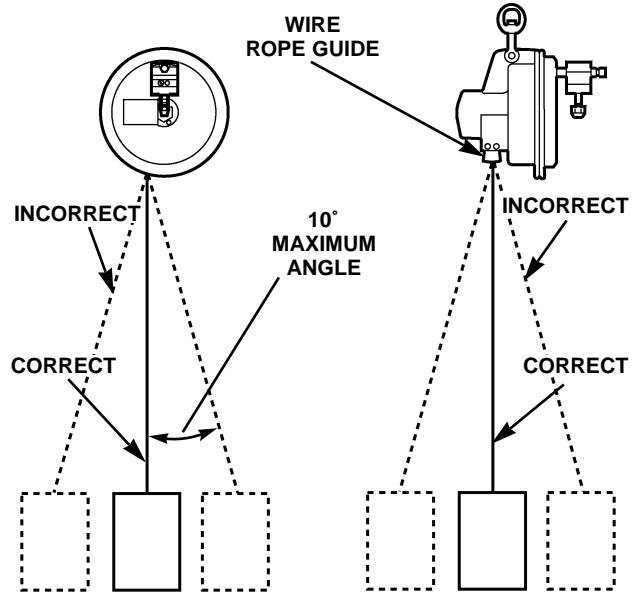

(Dwg. MHP1261)

## ⚠ CAUTION

- Use of replacement parts other than Ingersoll-Rand original parts could result in damage to the unit and void the warranty.

## ⚠ WARNING

- Turn off air supply to unit and be sure wire rope is slack before attempting any disassembly operations.

### Disassembly

Refer to Dwg. MHP1264.

1. Remove the unit from the overhead suspension.
2. Place the unit on a bench or suitable clean work surface.
3. Remove clamp (4), thimble (18) and load hook (5) from wire rope.
4. Remove screws (13) and nuts (15) from end cover (9).
5. Remove end cover (9).
6. Remove the diaphragm (10) from housing (8).
7. Remove piston (11) and thrust bearing (17) from ball screw and reel assembly (6 & 7).
8. Remove screw (20) from housing (8).
9. Remove liner (19) from housing (8).
10. Insert a 1/4 in. allen wrench in the end cover end of the ball screw assembly (6). Use a second allen wrench inserted into the ball screw bolt (14) and remove bolt (14).
11. Remove ball screw assembly (6) and reel (7) from housing (8). Insert a 1/4 in. drift punch in the hole the screw (14) was removed from and lightly tap to remove ball screw assembly from housing.

### Inspection

1. Examine the diaphragm for cracks and tears or lack of elasticity. If any found replace the diaphragm.
2. Inspect ball screw for excessive play, wear, pitting, rust, and smooth operation. If rough operation, loose, rusted, or worn excessively replace the ball screw assembly.
3. Inspect reel for excessive groove wear, anchor hole for deformation and security on ball nut assembly. If grooves are worn excessively or reel slides off of the ball nut replace the reel.
4. Inspect piston for nicks and gouges. Small nicks may be removed with fine emery cloth.
5. Inspect thrust bearing for excessive wear, and security of installation in the piston. If thrust bearing slides out replace the thrust bearing or the piston.

### Assembly

1. Insert the liner (19) into housing.
2. Attach the wire rope to the reel by inserting the plain end of the wire rope through the anchor hole of the reel. Insert the excess wire rope at the swage fitting into the reel just above the anchor hole. Refer to Dwg. MHP1262.
3. Wrap the wire rope around the reel three full wraps, and install into the housing and liner. Refer to Dwg. MHP1263.

4. Install ball screw bolt (14) and washer (16) into hole in the center of the housing (8), and hand tighten the ball screw assembly (6).
5. Use two allen wrenches, one inserted in the ball screw bolt (14) and one inserted in the opposite end of the ball screw assembly (6). Turn the allen wrench inserted in the ball screw assembly until the wire rope is aligned with screw hole (20), and the reel has three full wraps on it.
6. Hold the allen wrench inserted in the ball screw assembly and tighten the ball screw bolt (14).
7. Align the hole in the liner with the alignment hole in the housing and install liner screw (20).
8. Install the piston on to the reel assembly, a rubber mallet may be necessary to seat the piston to the reel.
9. Install the diaphragm into the housing bead side down. Use a soft rounded probe to seat the diaphragm between the piston and the housing walls.
10. Install the end cover using the six each screws (13), and nuts (15). Tighten the screws evenly in a cross pattern, similar to the lug nuts on an automobile wheel.
11. Install the wire rope guide using spring pins (3).
12. Install the regulator assembly as described in the "INSTALLATION" section.
13. Install the unit on the overhead suspension.
14. Install the wire rope clamp thimble and hook.
15. Perform (S) Operational Adjustments (Refer to page 5).

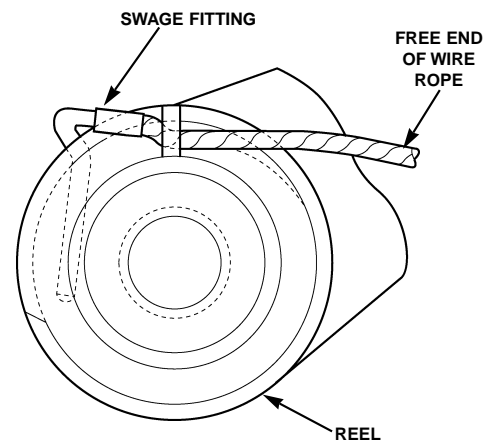

(Dwg. MHP1262)

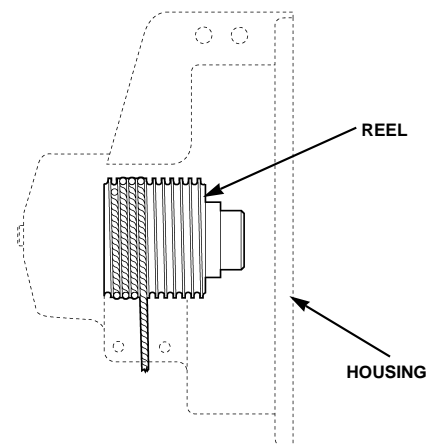

(Dwg. MHP1263)

## MODEL MW005060 LOAD POSITIONER DRAWING AND PARTS LIST

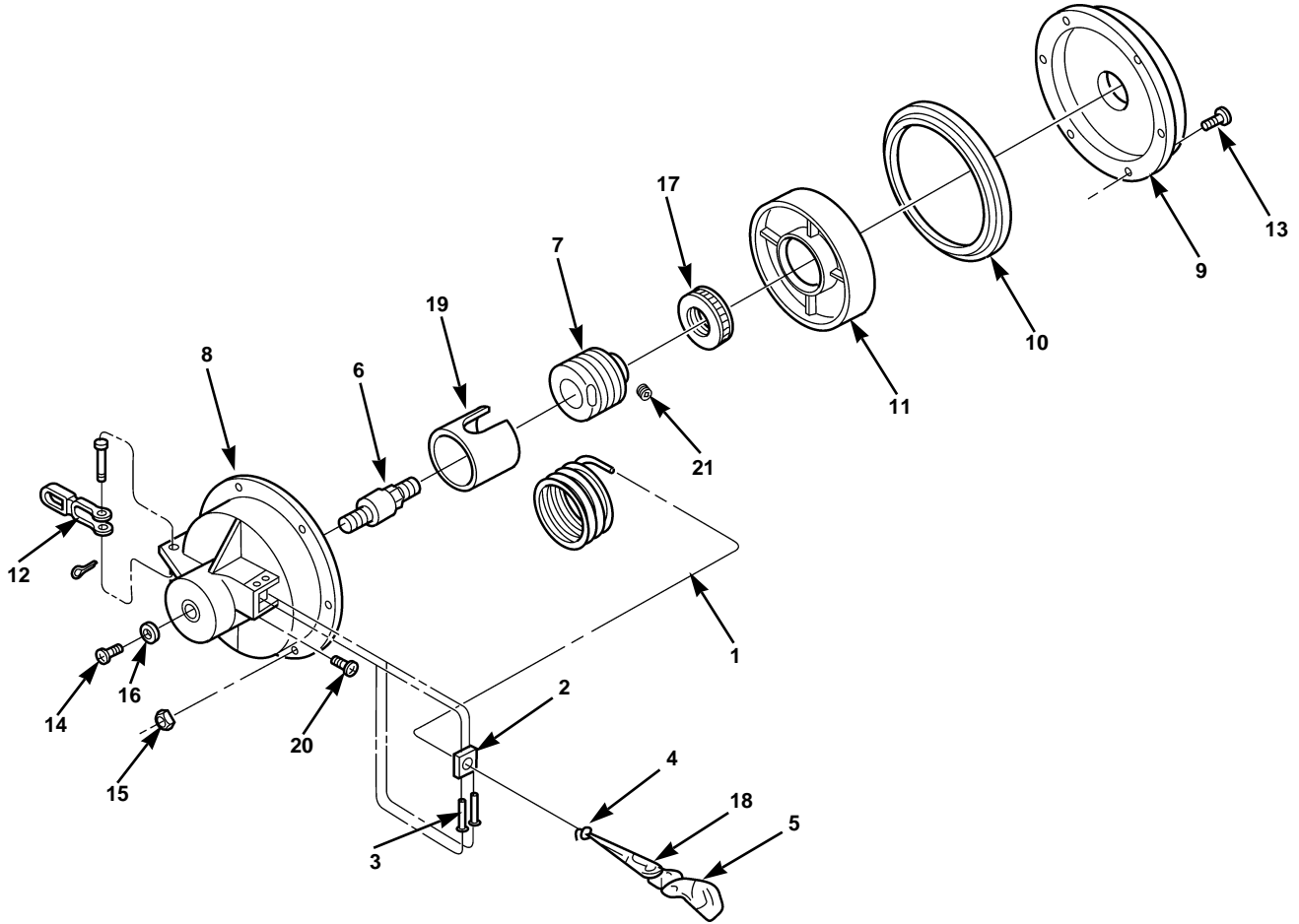

(Dwg. MHP1264)

Item No.	Description of Part	Qty. Total	Part Number	Item No.	Description of Part	Qty. Total	Part Number
• 1	Wire Rope Assembly	11	10089-12	12	Swivel Mounting	1	17090
2	Wire Rope Guide	11	10117	13	Screw, 1/4-20 x 1.25 Soc.	6	15779
3	Spring Pin, 3/16" x 2"	2	77057	14	Screw, 5/16-18 x 1.00 Soc.	1	70927
4	Wire Rope Clamp, 1/8"	2	10231	15	Nut, 1/4-20 Lock	6	75503
5	Load Hook	1	10234	16	Washer, 5/16 Hi-Collar	1	74531
6	Ball Screw & Nut Assy.	1	11015	17	Thrust Bearing	1	65060
7	Reel	1	11601	18	Wire Rope Thimble, 1/8"	1	10211
8	Housing	1	12302	19	Liner	1	12144
9	Cover	1	12305	20	Screw, 1/4-20 x 0.625 Flt. Head	1	70448
10	Diaphragm	1	14100	21	Setscrew, 1/4-20 x 0.500	1	70490
11	Piston	1	14150				

Recommended Spare

## PARTS ORDERING INFORMATION

These units are designed and constructed to provide long, trouble-free service. In time it may become necessary to order and install new parts to replace those that have been subjected to wear.

The use of other than **Ingersoll-Rand** Material Handling replacement parts may result in decreased unit performance, and may invalidate the warranty. For prompt service and genuine **Ingersoll-Rand** Material Handling parts, provide your nearest Distributor with the following:

1. Complete unit model number and serial number as it appears on the nameplate.
2. Part number and part description as shown in this manual.
3. Quantity required.

<b>M-SERIES LOAD POSITIONER</b>		<b>CE</b>
Model No.	MW005060	
Capacity	50 lbs. @ 100 psi	
Serial No.	00000	
<b>INGERSOLL-RAND</b>		Ingersoll-Rand Company
<b>MATERIAL HANDLING</b>		White House, TN

The model and serial number label is located on the unit housing.

For your convenience and future reference it is recommended that the following information be recorded.

**Model Number** \_\_\_\_\_

**Serial Number** \_\_\_\_\_

**Date Purchased** \_\_\_\_\_

### Return Goods Policy

If it becomes necessary to return the complete unit or certain parts to the factory, contact the Distributor from whom you purchased the unit, or the nearest **Ingersoll-Rand** Distributor in your locality. **Ingersoll-Rand** will not accept any returned goods for warranty or service work unless prior arrangements have been made and written authorization has been provided from the location where the goods were purchased.

### NOTICE

• Continuing improvement and advancement of design may cause changes to this unit which are not included in this manual. Manuals are periodically revised to incorporate changes. Always check the manual edition number on the front cover for the latest issue.

### Disposal

When the life of the unit has expired, it is recommended that the unit be disassembled, degreased and parts separated as to materials so that they may be recycled.

For additional information contact:  
**Ingersoll-Rand Co.**

Distribution Center  
510 Hester Drive  
P.O. Box 618  
White House, TN 37188  
Phone: (615) 672-0321  
Fax: (615) 672-0854

or

**Europe, Middle East and Africa  
Ingersoll-Rand Material Handling  
Douai Operations**  
111, avenue Roger Salengro  
59450 Sin Le Noble, France  
Phone: (33) 3-27-93-08-08  
Fax: (33) 3-27-93-08-00

**SERVICE NOTES**

## LIMITED WARRANTY

**Ingersoll-Rand** Company (I-R) warrants to the original user its Hoists and Winches (Products) to be free of defects in material and workmanship for a period of one year from the date of purchase. I-R will repair, without cost, any Product found to be defective, including parts and labor charges, or at its option, will replace such Products or refund the purchase price less a reasonable allowance for depreciation, in exchange for the Product. Repairs or replacements are warranted for the remainder of the original warranty period.

If any Product proves defective within its original one year warranty period, it should be returned to any Authorized Hoist and Winch Service Distributor, transportation prepaid with proof of purchase or warranty card.

This warranty does not apply to Products which I-R has determined to have been misused or abused, improperly maintained by the user, or where the malfunction or defect can be attributed to the use of non-genuine I-R parts.

**I-R makes no other warranty, and all implied warranties including any warranty of merchantability or fitness for a particular purpose are limited to the duration of the expressed warranty period as set forth above. I-R's maximum liability is limited to the purchase price of the Product and in no event shall I-R be liable for any consequential, indirect, incidental, or special damages of any nature rising from the sale or use of the Product, whether based on contract, tort, or otherwise.**

**Note:** Some states do not allow limitations on incidental or consequential damages or how long an implied warranty lasts so that the above limitations may not apply to you.

This warranty gives you specific legal rights and you may also have other rights which may vary from state to state.

## IMPORTANT NOTICE

It is our policy to promote safe delivery of all orders.

This shipment has been thoroughly checked, packed and inspected before leaving our plant and receipt for it in good condition has been received from the carrier. Any loss or damage which occurs to this shipment while enroute is not due to any action or conduct of the manufacturer.

### **VISIBLE LOSS OR DAMAGE**

If any of the goods called for on the bill of lading or express receipt are damaged or the quantity is short, do not accept them until the freight or express agent makes an appropriate notation on your freight bill or express receipt.

### **CONCEALED LOSS OR DAMAGE**

When a shipment has been delivered to you in apparent good condition, but upon opening the crate or container, loss or damage has taken place while in transit, notify the carrier's agent immediately.

### **DAMAGE CLAIMS**

You must file claims for damage with the carrier. It is the transportation company's responsibility to reimburse you for repair or replacement of goods damaged in shipment. Claims for loss or damage in shipment must not be deducted from the **Ingersoll-Rand** invoice, nor should payment of **Ingersoll-Rand** invoice be withheld awaiting adjustment of such claims as the carrier guarantees safe delivery.

You may return products damaged in shipment to us for repair, which services will be for your account and form your basis for claim against the carrier.

For Order Entry, Order Status  
and Technical Support contact:

**Ingersoll-Rand  
Distribution Center**

510 Hester Drive  
P.O. Box 618  
White House, TN 37188  
Phone: (615) 672-0321  
Fax: (615) 672-0854

**Europe, Middle East and Africa  
Ingersoll-Rand Material Handling  
Douai Operations**

111, avenue Roger Salengro  
59450 Sin Le Noble, France  
Phone: (33) 3-27-93-08-08  
Fax: (33) 3-27-93-08-00