

PARTS, OPERATION AND MAINTENANCE MANUAL for **M-SERIES LOAD POSITIONER**

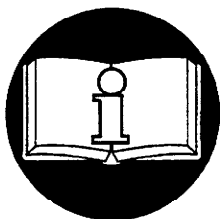
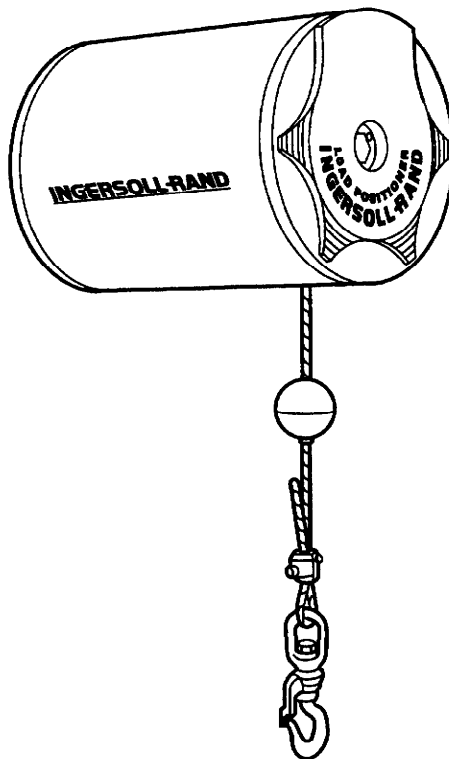

READ THIS MANUAL BEFORE USING THESE PRODUCTS. This manual contains important safety, installation, operation and maintenance information. Make this manual available to all persons responsible for the operation, installation and maintenance of these products.

⚠ WARNING

Do not use this unit for lifting, supporting, or transporting people or lifting or supporting loads over people.

Always operate, inspect and maintain this unit in accordance with applicable safety codes and regulations.

Refer all communications to the nearest Ingersoll-Rand Material Handling Office or Distributor.

Form MHD56141
Edition 1
June 1997
87300570
© 1997 Ingersoll-Rand Company

INGERSOLL-RAND
MATERIAL HANDLING

Basic Configurations

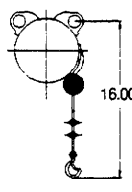
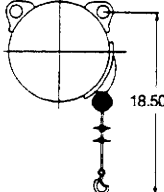
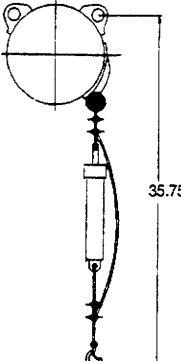
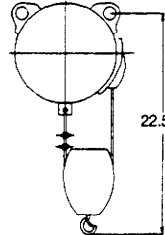
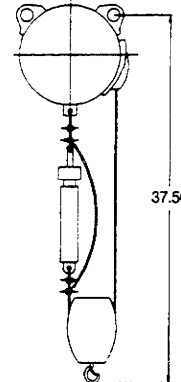
SINGLE			SINGLE			SINGLE W/ (S) CONTROL			REEVED			REEVED W/ (S) CONTROL		
														
CAPACITY	TRAVEL	DIM.	CAPACITY	TRAVEL	DIM.	CAPACITY	TRAVEL	DIM.	CAPACITY	TRAVEL	DIM.	CAPACITY	TRAVEL	DIM.
150 LBS.	80 IN.	16.0 IN.	200 LBS.	120 IN.	18.5 IN.	200 LBS.	120 IN.	35.75 IN.	400 LBS.	60 IN.	22.5 IN.	400 LBS.	60 IN.	37.5 IN.
			*350 LBS.	80 IN.	18.5 IN.	*350 LBS.	80 IN.	35.75 IN.	*700 LBS.	40 IN.	22.5 IN.	*700 LBS.	40 IN.	37.5 IN.
			*500 LBS.	80 IN.	18.5 IN.	*500 LBS.	80 IN.	35.75 IN.	*1000 LBS.	40 IN.	22.5 IN.	*1000 LBS.	40 IN.	37.5 IN.

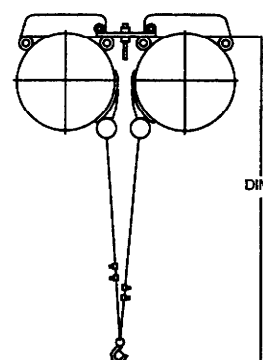
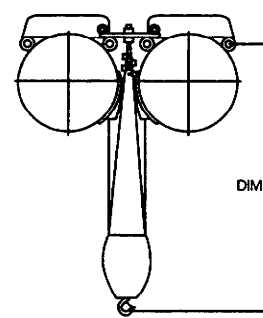
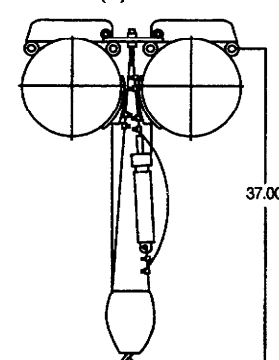
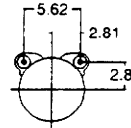
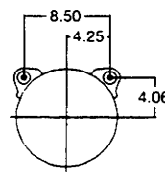
TANDEM			TANDEM REEVED			TANDEM REEVED W/ (S) CONTROL			EAR LOCATIONS ON 6.5 IN. UNIT EAR I.D. 1.31 IN. EAR LENGTH 1.875 IN.		
											
CAPACITY	TRAVEL	DIM.	CAPACITY	TRAVEL	DIM.	CAPACITY	TRAVEL	DIM.			
400 LBS.	120 IN.	35.25 IN.	800 LBS.	60 IN.	27.25 IN.	800 LBS.	60 IN.	37.0 IN.			
*700 LBS.	80 IN.	40.25 IN.	*1400 LBS.	40 IN.	37.25 IN.	*1400 LBS.	40 IN.	37.0 IN.			
*1000 LBS.	80 IN.	40.25 IN.	*2000 LBS.	40 IN.	37.25 IN.	*2000 LBS.	40 IN.	37.0 IN.			
									EAR LOCATIONS ON 10 IN. UNIT		
											

*Supplied with chain.

150 LB.	200 LB.	350 LB.	500 LB.
			
		WIRE ROPE 2.85 CHAIN 2.78	WIRE ROPE 3.62 CHAIN 3.51
			
150 LBS. CAPACITY	200/350 LBS. CAPACITY	500 LBS. CAPACITY	

Table of Contents

This Maintenance Manual describes the correct service, disassembly, assembly and repair procedures for the Ingersoll-Rand Load Positioner. Use of replacement parts other than genuine Ingersoll-Rand original parts could result in damage to the Unit and void the Warranty. Refer to back page of manual for warranty information. Be sure you read and understand all instructions before starting work on the unit.

Safety	3-7
Typical Basic Unit Cross Section	8
Principles of Operation	8
Model Identification	8
Pendant (P) Control Basic Unit	9-12
Manifold Installation	9
Control Hose Installation	9
Operational Adjustments	9
Manifold.....	10
Removal From Unit.....	10
Maintenance	10
P Control Handle.....	11
Removal From Unit.....	11
Maintenance	11
(P) Control Troubleshooting Guide	12
Single Balance (S) Control 6.5 in. Unit	13
Manifold Installation	13
Operational Adjustments	13
(S) Regulator	14
Single Balance Troubleshooting Guide 6.5 in. Unit	15
Single Balance (S) Control 10 in. Unit	16-18
Regulator Installation	16
Servo Installation.....	16
Operational Adjustments	16
Wire Rope and Chain Installation.....	17
Removal From Unit.....	18
Maintenance	18
(S) Control Troubleshooting Guide	19-20
(E) Control Basic Unit	21-23
Regulator Installation	21
Operational Adjustments	21
Removal From Unit.....	22
Maintenance	22-23
(E) Control Troubleshooting Guide	24-25
(E) Control and S Control 10 in. Unit Regulator	26-28
Removal From Unit.....	27
Maintenance	27-28
Tandem Control Unit	29
Tandem Control Installation	29

Load Hook Lash-up and Yarding	30
Load Hooks	31
Chain To Hook Assembly	31
Wire Rope To Hook Assembly	31
Load Blocks	32
Load Block Installation	32
Suspension Kits	34-40
Tandem Tie Bar Kit	40
Preventive Maintenance Checks and Service	41
Preventive Maintenance	41
Wire Rope and Load Hooks	41
Load Positioner Lubrication	41
Air Supply	41
Chain Lubrication	41
Units Not in Regular Use	41
Preventive Maintenance Schedule	42
Inspection and Maintenance Report	45
Unit Rebuild	46-53
Disassembly for 6.5 and 10 Inch Units - All Series	46
Disassembly of Ball Screw	47
Cleaning and Inspection	48
Ball Screw and Thrust Bearing Replacement	48
Ball Screw Reassembly	49
Reassembly	50-52
Installing Wire Rope	53
Installing Ball Stop.....	53
Installing Load Chain.....	53
Safety Retraction System Adjustments and Resetting	54-55
Safety Retraction System Reset Procedure	54
Safety Retraction System Adjustments	55
Basic Model 150	56
Safety Retraction Assembly — 150 lb. Unit	56
Basic Model 200/350/500	57
Safety Retraction Assembly — 200/350/500 lb. Unit	57
Optional Model 200/325/500	58
Down Stop Assembly	58
Basic Model 150	59
150 lb. Unit	59
Basic Model 200	60
200 lb. Unit	60
Basic Model 350	61
350 lb. Unit	61
Basic Model 500	62
500 lb. Unit	62

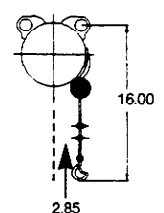
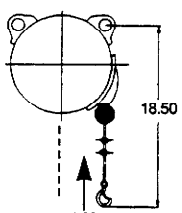
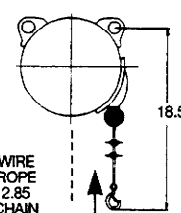
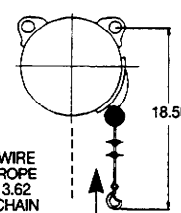
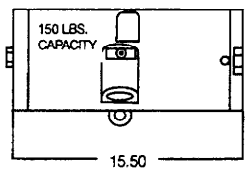
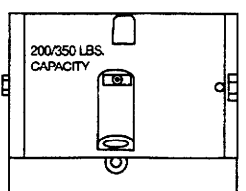
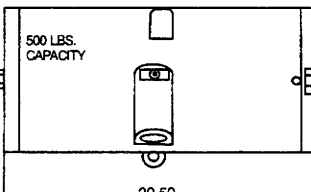
Safety Information

This manual provides important information for all personnel involved with the safe installation, operation and proper maintenance of this product. Even if you feel you are familiar with this or similar equipment, you should read this manual before operating the unit.

Danger, Warning, Caution and Notice

Throughout this manual there are steps and procedures which, if not followed, may result in an injury. The following signal words are used to identify the level of potential hazard.



Danger is used to indicate the presence of a hazard which **will** cause **severe** injury, death, or substantial property damage if the warning is ignored.



Warning is used to indicate the presence of a hazard which **can** cause **severe** injury, death, or substantial property damage if the warning is ignored.



Caution is used to indicate the presence of a hazard which **will** or **can** cause injury or property damage if the warning is ignored.

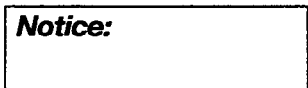

Notice is used to notify people of installation, operation, or maintenance information which is important but not hazard-related.

Safety Summary



WARNING

- **Do not use this unit or attached equipment for lifting, supporting, or transporting people or lifting or supporting loads over people.**
- **The supporting structures and load-attaching devices used in conjunction with these units must provide a safety factor of at least three times the rated capacity of the unit. This is the customer's responsibility. If in doubt, consult a registered structural engineer.**

Notice: Lifting equipment is subject to different regulations in each country. These regulations may not be specified in this manual.

The National Safety Council, Accident Prevention Manual for Industrial Operations, Eighth Edition and other recognized safety sources make a common point: Employees who work near suspended loads or assist in hooking on or arranging a load should be instructed to keep out from under the load. From a safety standpoint, one factor is paramount: conduct all lifting operations in such a manner that if there were an equipment failure, no personnel would be injured. This means keep out from under a raised load and keep out of the line of force of any load.

The Occupational Safety and Health Act of 1970 generally places the burden of compliance with the owner/employer, not the manufacturer. Many OSHA requirements are not concerned or connected with the manufactured product but are, rather, associated with the final installation. It is the owner's responsibility and user's responsibility to determine the suitability of a product for any particular use. It is recommended that all applicable industry, trade association, federal, state, and local regulations be checked. Read all operating instructions and warnings before operation.

Rigging: It is the responsibility of the operator to exercise caution, use common sense and be familiar with proper rigging techniques. See ASME B30.9 for rigging information, American National Standards Institute, 1430 Broadway, New York, NY 10018.

This manual has been produced by **Ingersoll-Rand** to provide dealers, mechanics, operators and company personnel with the information required to install, operate, maintain and repair the products described herein. It is extremely important that mechanics and operators be familiar with the servicing procedures of these products, or like or similar products, and are physically capable of conducting the procedures. These personnel shall have a general working knowledge that includes:

1. Proper and safe use and application of mechanics common hands tools as well as special **Ingersoll-Rand** or recommended tools.
2. Safety procedures, precautions and work habits established by accepted industry standards.

Ingersoll-Rand can not know of, nor provide all the procedures by which product operations or repairs may be conducted and the hazards and/or results of each method. If operation or maintenance procedures not specifically recommended by the manufacturer are conducted, it must be ensured that product safety is not endangered by the actions taken. If unsure of an operation or maintenance procedure or step, personnel should place the product in a safe condition and contact supervisors and/or the factory for technical assistance.



WARNING

Ingersoll-Rand units with capacities of 150 lbs or greater are equipped with the Safety Retraction System, a centrifugal brake that is designed to stop the uncontrolled upward travel of the chain or wire rope in the event of a sudden release or loss of load, and limit the excessive upward acceleration of the empty hook for the safety of the operators. The brake should in no instances be used as a travel limiting stop or up stop. Failure to follow these instructions will result in damage to the brake and the unit. Continuous use of the Safety Retraction System will cause internal damage to the unit and could result in damaging the unit beyond repair.

SAFETY

SAFE INSTALLATION AND OPERATION OF INGERSOLL-RAND UNITS DEPEND ON YOU READING AND UNDERSTANDING ALL INSTRUCTIONS BEFORE STARTING WORK ON THE UNIT.



CAUTION

Clean, dry air must be used at all times when operating these units.

Safe Operating Instructions

The following warnings and operating instructions have been adapted in part from American National (Safety) Standards and are intended to avoid unsafe operating practices which might lead to injury or property damage.

Ingersoll-Rand recognizes that most companies who are using these units have a safety program in force at their facility. In the event that some conflict exists between a rule set forth in this publication and a similar rule already set by an individual company, the more stringent of the two should take precedence.

Safe Operating Instructions are provided to make an operator aware of dangerous practices to avoid and are not necessarily limited to the following list. Refer to specific sections in the manual for additional safety information.

1. Only allow personnel trained in safety and operation of this unit to operate this product.
2. Only operate the unit if you are physically fit to do so.
3. When a "DO NOT OPERATE" sign is placed on the unit, or controls, do not operate the unit until the sign has been removed by designated personnel.
4. Do not use the unit if hook gate has been sprung or broken.
5. Check that the hook gates are closed before using.
6. Before each shift, check the unit for wear and damage. Never use a unit that inspection indicates is worn or damaged.
7. Never lift a load greater than the rated capacity of the unit. See capacity labels attached to the unit.
8. Do not use more than one hook on a single load.

9. Never place your hand inside the throat area of a hook.
10. Never use the wire rope or chain as a sling.
11. Only operate the unit when the wire rope or chain is centered over the load. Do not “side pull” or “yard”.
12. Never operate the unit with twisted, kinked or damaged wire rope or chain.
13. Do not force hook into place by hammering.
14. Be certain the load is properly seated in the saddle of the hook.
15. Do not support the load on the tip of the hook.
16. Never run the wire rope or chain over a sharp edge.
17. Pay attention to the load at all times when operating the unit.
18. Make sure everyone is clear of the load path. Do not lift a load over people.
19. Never use the unit for lifting or lowering people, and never allow anyone to stand on a suspended load.
20. Do not swing a suspended load.
21. Do not leave load suspended when the unit is not in use.
22. Never leave a suspended load unattended.
23. Never weld or cut a load suspended by the unit.
24. Ensure safety Wire Rope is installed (where required).
25. Do not operate the unit if wire rope or chain are jumping, excessive noise, jamming, overloading, or binding occurs.
26. Shut off air supply before performing any maintenance.
27. Avoid collision or bumping of the units.

Warning Label

Each unit is shipped from the factory with the warning label shown. If the label is not attached to the unit, order a new label and install it. See the parts list for the part number. Label is shown smaller than actual size.

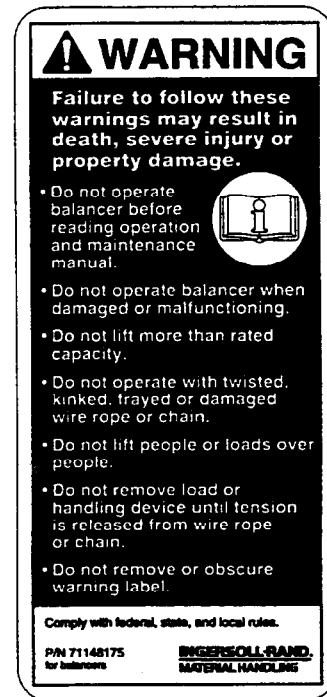

Installation

Prior to installing the unit, carefully inspect it for possible shipping damage. The units are supplied fully lubricated from the factory.



CAUTION

- Owners and users are advised to examine specific, local or other regulations, including American National Standards Institute and/or OSHA Regulations which may apply to a particular type of use of this product before installing or putting the unit to use.
- A falling load can cause injury or death. Before installing, read "SAFETY INFORMATION".

Load Positioner

Make certain the unit is properly installed. A little extra time and effort in so doing can contribute a lot toward preventing accidents and helping you get the best service possible.

Always make certain the supporting member from which the unit is suspended is strong enough to support the weight of the unit plus the weight of a maximum rated load plus a generous factor of at least 300% of the combined weights.

If the unit is suspended by a top hook, the supporting member should rest completely within the saddle of the hook and be centered directly above the hook shank. Do not use a supporting member that tilts the unit to one side or the other.

Hook Mounted Load Positioner Installation

Place hook over mounting structure. Make sure hook gate is engaged.

Trolley Mounted Load Positioner Installation

When installing the unit and trolley on the beam, make certain the side plates are parallel and vertical. After installation, operate the trolley over the entire length of the beam with a capacity load. Ensure rail stops are installed before operating the unit. Use Grade 5 or better bolts when attaching unit to trolley assembly. Refer to Trolley Suspension Kit in this manual.



CAUTION

To avoid an unbalanced load which may damage the trolley, the unit must be centered under the trolley.

Rail Mounted Load Positioner Installation

For proper and safe installation of the unit on a rail system refer to Installation and Maintenance Manual for that rail system.

Air System

The supply air must be clean and free from water or moisture. A minimum of 100 psi (6.9 bar/690 kPa) at the unit is required to provide rated capacity. Do not exceed 100 psi.



WARNING

Do not exceed 100 psi inlet pressure. Do not use a lubricator of any kind. Oil will damage internal components.

Air Lines

The inside diameter of the unit air supply lines must not be smaller than 3/8 in. (10 mm) based on a maximum of 100 ft. (30 m) between the air supply and the unit. Contact the factory for recommended air line sizes for distances greater than 100 ft. (30 m). Before making final connections, all air supply lines should be purged before connecting to unit inlet. Supply lines should be as short and straight as installation conditions will permit. Long transmission lines and excessive use of fittings, elbows, tees, globe valves, etc. cause a reduction in pressure due to restrictions and surface friction in the lines. If quick-disconnect fittings are used at the inlet of the unit, they must have at least a 3/8 in. (10 mm) air passage. Use of smaller fittings will reduce performance.

Air Line Filter

It is recommended that an air line strainer/filter be installed as close as practical to the unit air inlet port. The strainer/filter should provide 10 micron filtration and include a moisture trap. Clean the strainer/filter monthly to maintain its operating efficiency.

To maintain dry air, the frequency for draining the filter should also be based on the condition of the air supply. We suggest the filter be drained weekly at first. Depending on air supply condition, a proper filter drain schedule should be established.

Moisture in Air Lines

Moisture that reaches the unit through the supply lines is the chief factor in determining the length of time between service overhauls. Moisture traps can help to eliminate moisture. Other methods, such as an air receiver which collects moisture before it reaches the unit controls or an aftercooler at the compressor that cools the air prior to distribution through the supply lines, are also helpful.

Typical Basic Unit Cross Section

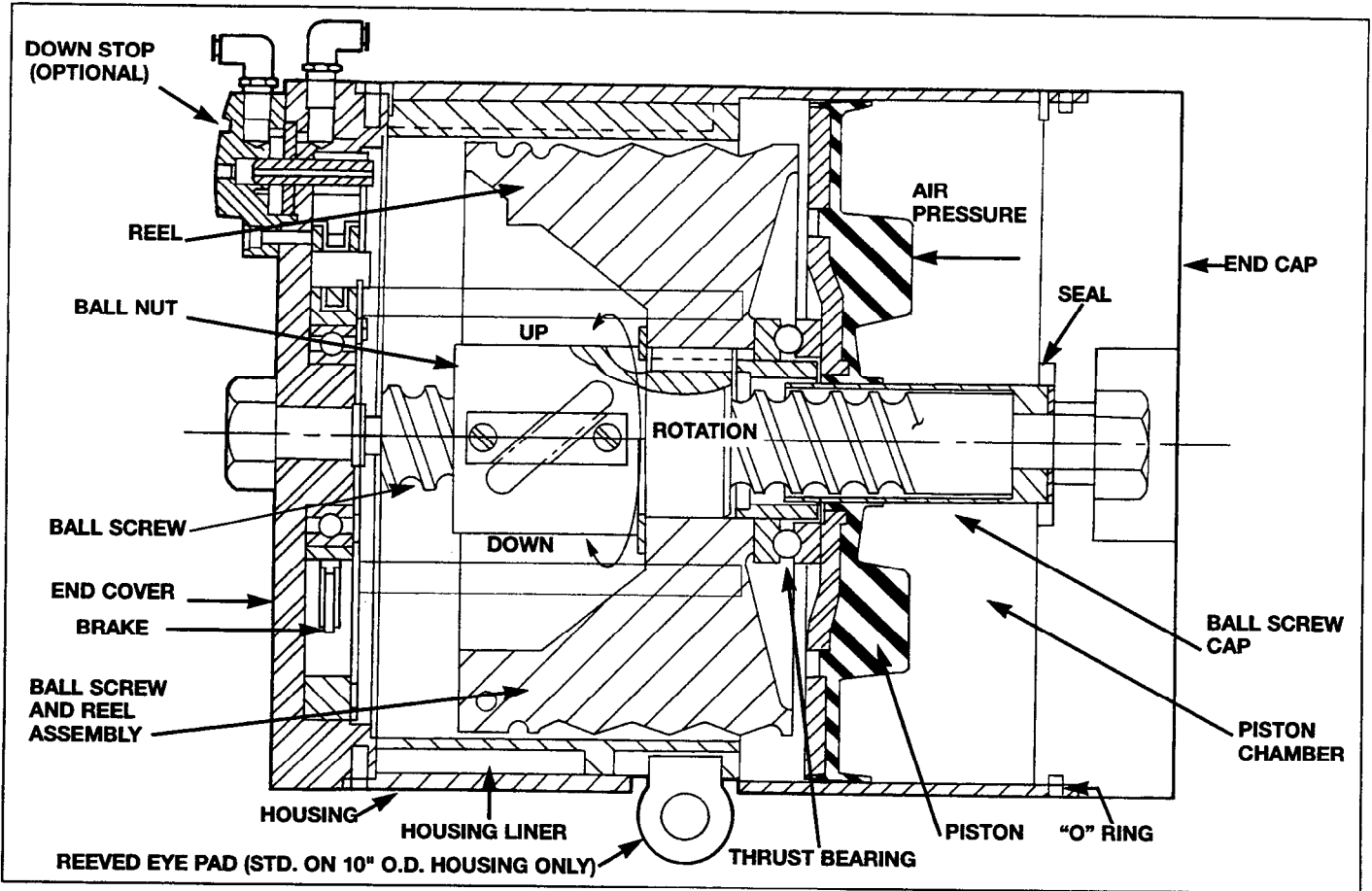

Principle of operation:

The ball screw is stationary. It is held in position by two hex head bolts (through the end cap and end cover). Two pins in the end cover engage notches on the end of the ball screw to prevent it from rotating. The reel assembly, consisting of reel, ball nut and thrust bearing, rides on the ball screw. The piston contacts the thrust bearing and travels back and forth with reel assembly. The piston does not rotate.

Compressed air powers the unit. It is controlled by an external control package. Air enters or leaves the piston chamber through a single hole in the end cap. This compressed air causes the piston to move laterally. The piston pushes against the thrust bearing causing the reel to move laterally along the ball screw and winds up the wire rope. The load or hook travels down when the air is exhausted from the piston chamber through the control package to atmosphere.

Capacity in lbs. (kg)	
Wire	Chain
*005 = 50 (22)	032 = 325 (147)
*015 = 150 (68)	*035 = 350 (158)
020 = 200 (90)	050 = 500 (227)
032 = 325 (147)	065 = 650 (294)
*035 = 350 (158)	*070 = 700 (317)
040 = 400 (181)	100 = 1000 (453)
050 = 500 (227)	
065 = 650 (294)	
*070 = 700 (317)	
080 = 800 (362)	
100 = 1000 (453)	
130 = 1300 (589)	
*140 = 1400 (365)	
200 = 2000 (907)	

*Not available with Down Stop option.

Control
B = Basic-no controls
P = Pendant control
S = Single balance control
E = Hi, low, no load control

Model No. MW 005 060 00 S S

Series MW = Wire Rope MC = Chain	Suspension 00 = No Suspension SR = IRS2/S3 V2 = ValuTrak HM = Hook Mount TR = T-Rail/I-Beam AT = ZRAT A1 = ZRA1 A2 = ZRA2 K1 = KBK1 K2 = KBK2 E4 = ETA-4 E8 = ETA-8 GB = Gorbel	Options S = Down Stop
---	---	---------------------------------

Travel
 060 = 60 inches. Travel distance is determined by series and capacity, and is not a variable option. See model no. in specifications chart. Example: MW005060

Pendant (P) Control Basic Unit

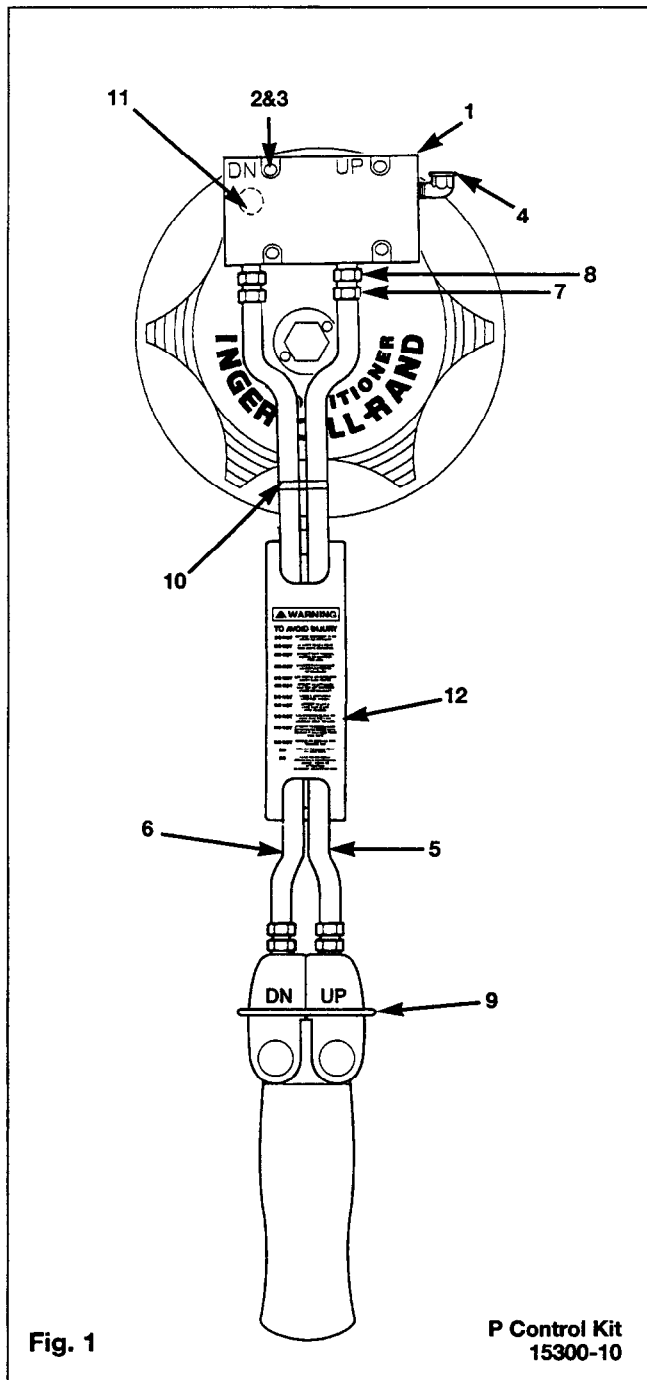

Fig. 1

Manifold Installation Refer to Fig. 1.

Place the unit on a clean, sturdy work surface with end cap upright. Remove the P control kit from its package and make certain that the "O" Ring (11) is in place on back of the manifold. Install manifold (1) with mounting screws and lock washers (2 & 3).

Control Hose Installation

The control hose is pre-assembled to the control handle, but it must be attached to the manifold.

Control hose assemblies will be gray and black straight hose. The gray hose (6) must be connected to the down side of the manifold. The black hose (5) must be connected to the up side of the manifold.

Operational Adjustments

! WARNING
Prior to performing operational adjustments or servicing make sure air supply is off. Press down lever until wire rope is slack.

1. Close the up and down control valves (located on top of 15071 manifold) completely. Open them 1 full turn.
2. Turn the hook balance adjustment screw (Fig. 2 IT.11) counter-clockwise until the head of the screw is flush with the top surface of the manifold body.
3. Turn on the air supply.

Notice: When the wire rope is winding, air is entering the unit through both the up and down flow controls. Therefore, the down flow control also affects the up speed when it is set for a minimal down speed.

4. To adjust the up or down speed, turn the corresponding control valves:
 - Counter-clockwise to increase speed.
 - Clockwise to decrease speed.
5. Turn the hook balance adjustment (center screw) clockwise until the empty handling device rises slowly. Back off the adjustment until the empty handling device stops rising.

Item	Part #	Description	Qty
1	15071	Manifold	1
2	15785	Lock Washer	4
3	15779	Mounting Screw	4
4	10354	Elbow Fitting	1
5	10555-B	Hose	1
6	10555-G	Hose	1

Item	Part #	Description	Qty
7	10560	Fitting	4
8	10565	Adapter	4
9	18600	Ergonomic Control Handle	1
10	10548	Clamp	4
11	15751	"O" Ring	1
12	10445	Safety Tag (must not be removed)	1

(P) Manifold

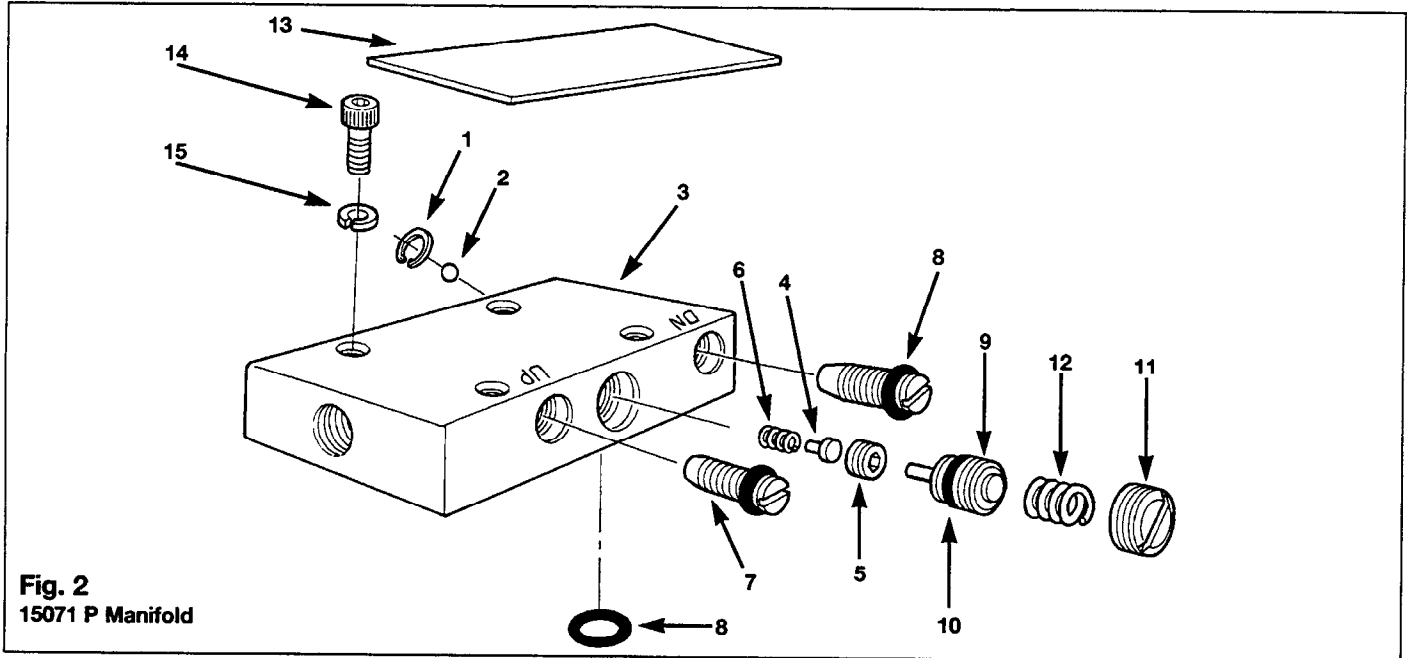

Fig. 2
15071 P Manifold

Removal From Unit

1. Lower suspended load to floor. Turn off air supply to unit and press down lever until wire rope is slack. Refer to Fig. 1.
2. Remove air supply (4) and hoses (5 & 6) from manifold (1).
3. Remove the four screws holding manifold to end cap (2 & 3).

Disassembly Refer to Fig. 2.



CAUTION

Use of replacement parts other than genuine Ingersoll-Rand original parts could result in damage to the Unit and void the Warranty.

1. Remove the two adjustment screws (7). Pull out when threads have disengaged.
2. Remove hook balance adjustment screw (11) and spring (12).
3. Remove piston (9) by grasping raised center with needle nose pliers and pulling straight out.
4. Remove seat (5), valve (4) and spring (6). Use a No. 2 phillips screwdriver to unscrew seat (5).
5. To take out the ball check (2), remove the down side hose fitting and snap-ring (1).

Reassembly

1. Thoroughly clean the manifold body and all internal parts before reassembly. Replace all worn parts.
2. Apply a light coat of lubricant (Lubriplate) to "O" Rings (8), U-cup (10), and threaded adjustments before reassembly.
3. Reassemble manifold in reverse order of disassembly.

Item	Part #	Description	Qty
1	*15047	Snap ring – P Manifold	1
2	*15049	Ball, Check – P Manifold	1
3	15077	Body – P Manifold	1
4	*15802	Valve Assembly	1
5	*15803	Valve Seat	1
6	*15804	Valve Spring	1
7	15080	Screw, Adjusting P Manifold	2
8	*15751	"O" Ring	3
9	15083	Piston – P Manifold	1
10	*15086	U-cup – P Manifold	1
11	15081	Screw, Adjusting P Manifold	1
12	15084	Spring – P Manifold	1
13	10297	Name Plate, Series P Manifold	1
14	15779	Mounting Screw	4
15	15785	Lock Washer	4

SUGGESTED SPARE PARTS AVAILABLE IN KIT
*15099 – P MANIFOLD REPAIR KIT

(P) Control Handle

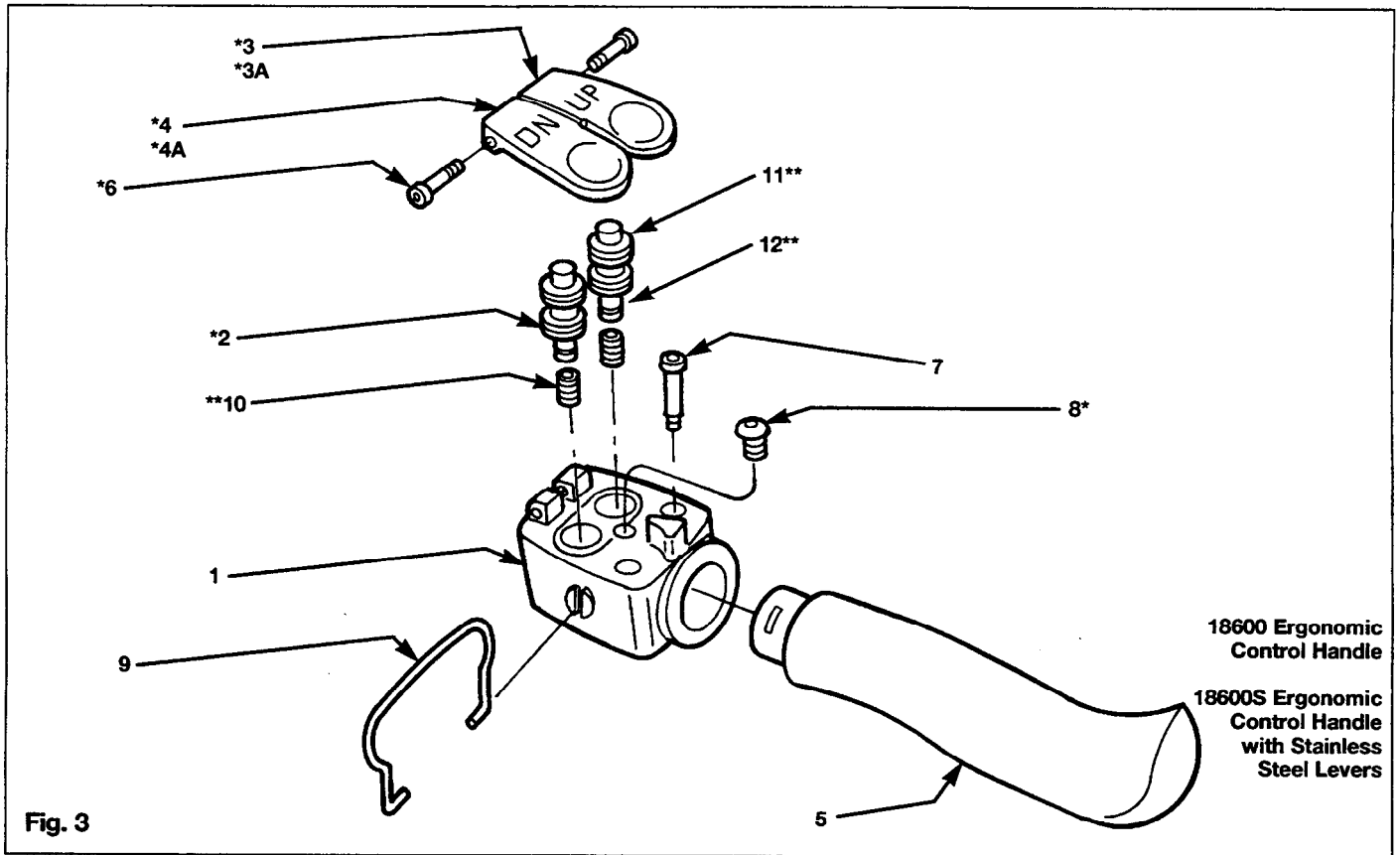

Removal From Unit Refer to Fig. 1.

1. Lower suspended load and turn off air supply to unit and press down lever until wire rope is slack.
2. Disconnect twin hose (5 & 6) at handle (9).

Disassembly Refer to Fig. 3.



CAUTION

Use of replacement parts other than genuine Ingersoll-Rand original parts could result in damage to the Unit and void the Warranty.

1. Remove screws (6) and UP and DOWN levers.
2. Remove screw (8).
3. Remove the two insert valve cartridges (2) by pulling them straight out.
4. Remove two springs (10). Check valve springs for breakage or loss of tension. Replace springs, if necessary. Examine the rubber seat on the end of the valve stem. Examine "O" Rings for signs of wear or deterioration. Clean valve body (1).
5. Replace all worn parts.

Reassembly

1. The control handle is reassembled in the reverse order of disassembly.
2. Apply a light coat of lubricant (10886) to "O" rings and threaded connections before reassembly.

Item	Part No.	DESCRIPTION	Qty.
1	18603	Valve Body	1
2	*18602	Cartridge Valve	2
3	*18609	Up Lever	1
3A	*18609S	Stainless Steel Up Lever	1
4	*18607	Down Lever	1
4A	*18607S	Stainless Steel Down Lever	1
5	18604	Handle	1
6	*70021	Shoulder Screw	2
7	70022	Shoulder Screw	1
8	*70422	Button Head Screw	1
9	18612	Guard	1
10	**18613	Spring	2
11	**16333	"O" Ring	1
12	**18632	Quad Ring	1

SUGGESTED SPARE PARTS ARE AVAILABLE IN KIT

*18575 - CONTROL HANDLE REPAIR KIT

*18575S - CONTROL HANDLE WITH STEEL LEVER REPAIR/UPGRADE KIT

**18570 - CARTRIDGE VALVE REPAIR KIT

(P) Control Troubleshooting Guide



CAUTION

Before doing any disassembly, lower load until wire rope is slack. Prior to performing operational adjustments or servicing make sure air supply is off.

Basic Unit – Refer to Applicable Breakdown for Parts

PROBLEM	POSSIBLE CAUSE	SOLUTION
Unit will not lift or hold load. Air leaking from inside housing.	<ol style="list-style-type: none"> 1. End cap "O" ring leaking. 2. Ball screw cap, seal leaking air. 3. Air leak around piston. 4. Cap (ball screw) may be damaged. 	<ol style="list-style-type: none"> 1. Replace "O" Ring. 2. Tighten hex head bolt in center of end cap. Remove if leak continues and replace seal. 3. Replace piston. 4. Replace cap (ball screw).
Unit will not lift load. No air leaking from the unit.	<ol style="list-style-type: none"> 1. Safety Retraction System engaged. 	<ol style="list-style-type: none"> 1. Lower load, refer to Safety Retraction System adjustment and resetting procedure, Pg. 54.
Unit lifts but will not lower.	<ol style="list-style-type: none"> 1. Control hoses installed backwards. 	<ol style="list-style-type: none"> 1. Reverse hoses, See Pg. 5.

(P) Basic Control

PROBLEM	POSSIBLE CAUSE	SOLUTION
Unit will lift, but will not hold load.	<ol style="list-style-type: none"> 1. Air leak between manifold and unit end cap. 2. Air leak around up/down adjustment screws on manifold. 3. Air leak around hook balance adjustment screw on manifold. 4. Worn or cut control air lines. 5. Improper assembly of hose fittings (leakage). 6. Air leaks around or through "down" valve assembly in control handle. 	<ol style="list-style-type: none"> 1. Replace "O" Ring (15751). 2. Replace "O" Ring (15751). 3. Replace U-cup (15086) or replace ball (15049). 4. Replace control air line. 5. Check and tighten fittings. Apply pipe sealant if necessary. 6. Clean and inspect assembly. Replace worn parts.
Unit lifts load without up lever being actuated.	<ol style="list-style-type: none"> 1. Hook balance adjustment set too high. 2. Air leak around or through "up" valve assembly in control handle. 	<ol style="list-style-type: none"> 1. Turn adjusting screw (15081) counter-clockwise until screw head is flush with top of manifold. If problem continues rebuild manifold. Refer to Pg. 10. 2. Clean and inspect assembly. Replace worn parts.

Single Balance (S) Control 6.5 in. Unit

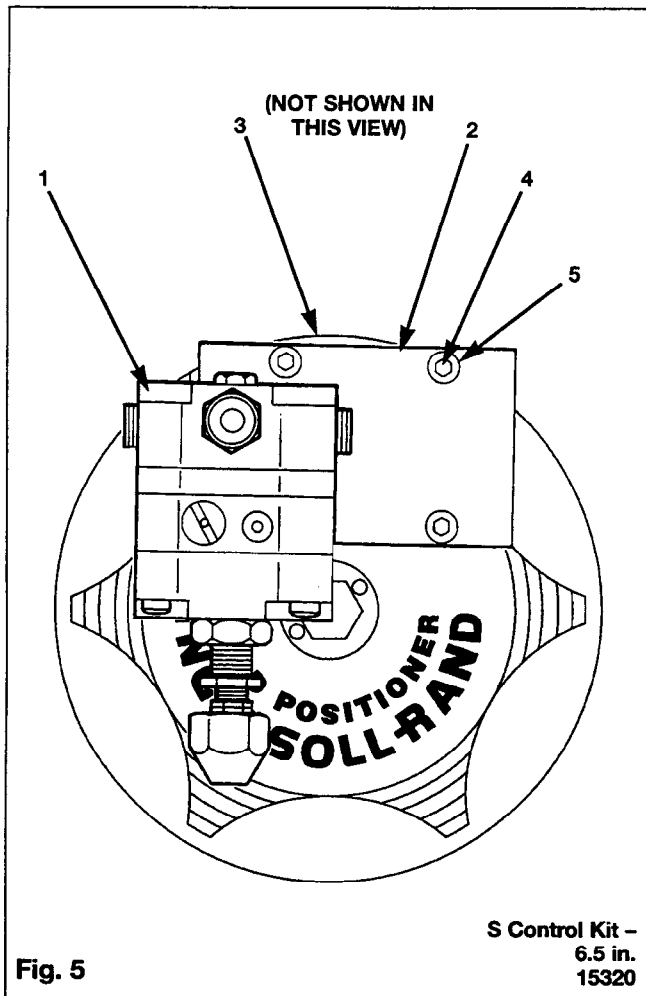

Item	Part #	Description	Qty.
1	13825	Regulator Assembly	1
2	15093	Tandem Manifold	1
3	15751	"O" Ring	1
4	15779	Mounting Screw	4
5	15785	Lock Washer	4

Manifold Installation Refer to Fig. 5.

Place the unit on a clean, sturdy work surface with the end cap upright. Remove the S control kit from its package. Check to be sure the "O" Ring (3) is in place on the back side of the manifold (2). Install the manifold to the end cap by using the 4 mounting screws and lock washers (4 & 5) provided. The regulator is supplied with a hex nipple and a check valve. The hex nipple should be threaded into the hole on the manifold as shown in Figure 7. Connect the air supply to the check valve.

Notice: The arrow on the check valve must be pointing toward the unit. If installed backwards the unit will not function.

Operational Adjustments



WARNING

Prior to performing operational adjustments or servicing make sure air supply is off and wire rope is slack.

1. Turn adjustment knob counter-clockwise until it stops.
2. Attach load to the end of the wire rope.
3. Turn on air supply.
4. By turning the regulator adjustment knob clockwise, you increase the balancing capacity.
5. By turning the regulator adjustment knob counter-clockwise, you decrease the balancing capacity.
6. To properly adjust the unit, turn the adjustment knob so that it takes equal effort to move the load up and down.
7. Tighten lock nut on regulator stem to ensure adjustment is maintained.

(S) Regulator

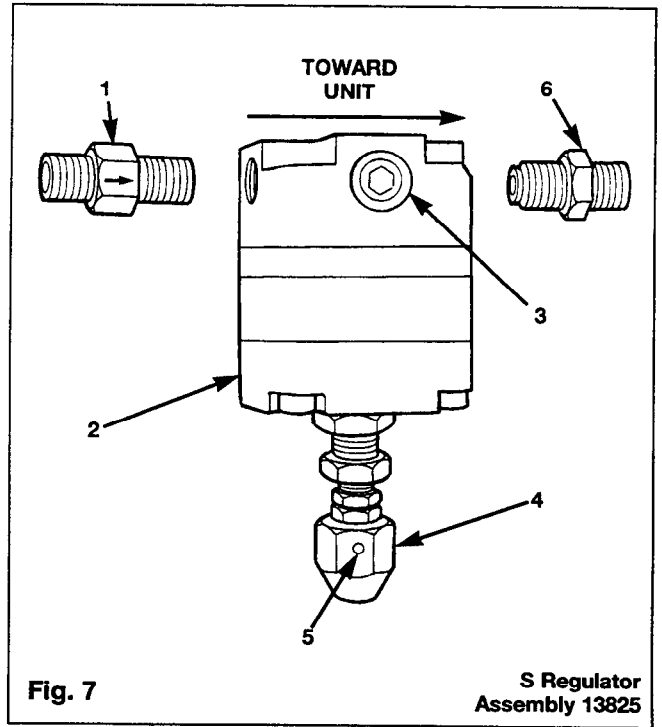
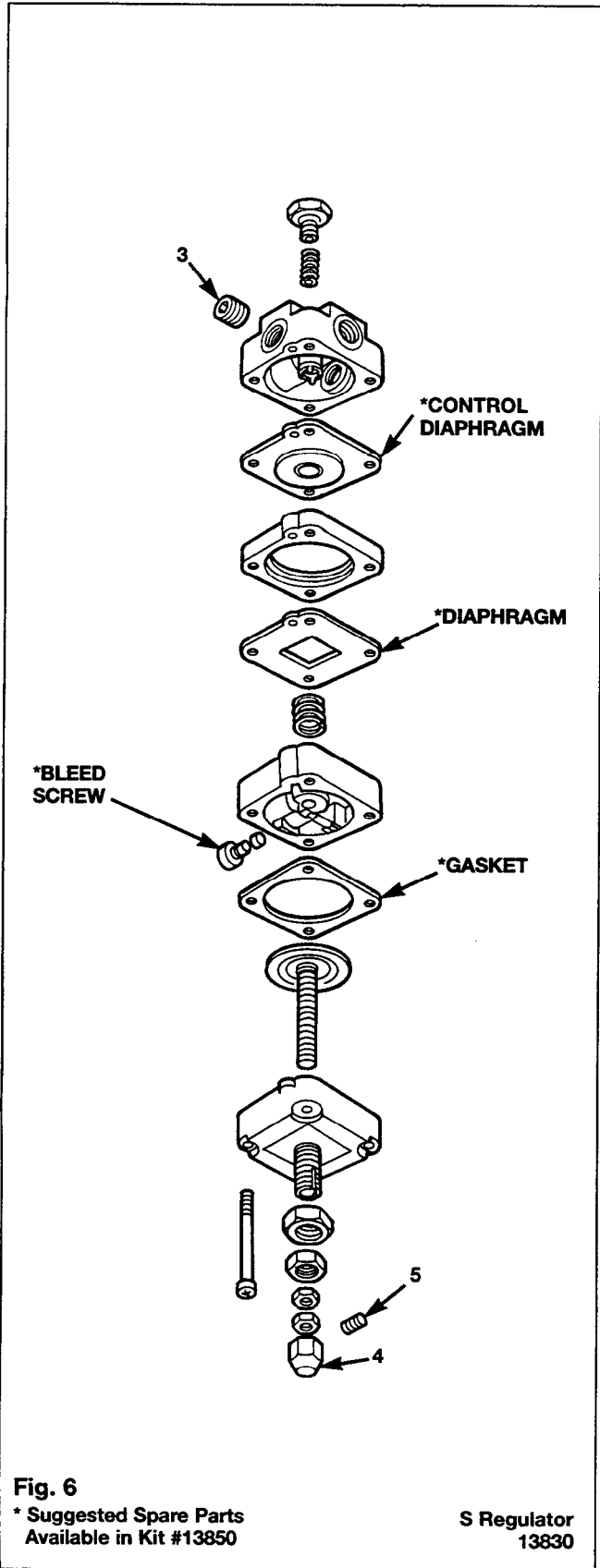

Item	Part #	Description	Qty.
1	13270	Check Valve	1
2	13830	Regulator	1
3	10764	Plug	2
4	13832	Control knob	1
5	13833	Soc Set Screw	1
6	13840	Hex Nipple	1

Single Balance Troubleshooting Guide 6.5 in. Unit



CAUTION

Before doing any disassembly, lower load and turn control knob (counter-clockwise) until wire rope is slack. Prior to performing additional adjustments or servicing make sure air supply is off.

PROBLEM	POSSIBLE CAUSE	SOLUTION
Unit will not lift load. <i>Notice: Make sure load does not exceed capacity of unit.</i>	<ol style="list-style-type: none"> 1. Check valve installed backwards. 2. Regulator adjustment set low. 3. Insufficient air pressure. 4. Excessive leakage around piston, "O" Ring or seal on end cap. 5. Binding of ball screw assembly, or thrust bearing. 	<ol style="list-style-type: none"> 1. Install check valve properly, arrow toward regulator. 2. Turn adjustment clockwise until load rises. 3. Increase pressure to 100 psi. 4. Check for damaged piston, seal or "O" ring. Replace worn parts. 5. Clean and lubricate ball screw assembly and thrust bearing, or replace if excessively worn.
Load rises but is hard to pull down.	<ol style="list-style-type: none"> 1. Regulator adjustment set too high. 2. Exhaust hole in regulator bleed screw plugged. 	<ol style="list-style-type: none"> 1. Back off adjustment (counter-clockwise) until load is balanced. 2. Clean exhaust hole using fine wire, or replace bleed screw.
Air constantly blowing out of exhaust ports on regulator.	<ol style="list-style-type: none"> 1. Ruptured diaphragm in regulator. 	<ol style="list-style-type: none"> 1. Replace diaphragm.
Erratic, jerky operation.	<ol style="list-style-type: none"> 1. Fluctuating air supply pressure. 2. Dirt or oil clogging inlet valve or bleed screw orifice. 3. Ball screw and thrust bearing dirty. 	<ol style="list-style-type: none"> 1. Clean parts thoroughly. 2. Clean thoroughly and lubricate. 3. Install line regulator set at highest maintainable pressure. Do not exceed 100 psi.

Single Balance (S) Control 10 in. Unit

Servo Installation

Mount the unit on overhead suspension, with wire rope or chain fully extended. Determine proper wire rope location for the Servo, refer to the load hook lash up portion of manual. Attach the Servo valve to wire rope or chain as shown on page 14, Figures 9 & 10.

Operational Adjustments

Refer to Fig. 8.

Notice: You must have a minimum of 70 psi to operate the regulator.

WARNING
Prior to performing operational adjustment or servicing make sure air supply is off and wire rope is slack.

1. Turn the pilot regulator screw counter-clockwise until 1/2" of thread is visible.
2. Adjust the auxiliary flow control screw by turning clockwise completely.
3. Adjust the trim valve by turning the screw clockwise completely and then turning counter-clockwise 1 to 2-1/2 full turns.
4. Attach the Servo to the wire rope or chain as shown in Fig. 9 & 10. Do not connect air line (6) from regulator to Servo at this time.
5. Attach load hook to wire rope and load.
6. Connect and turn on the air supply. Set supply line regulator so that the unit receives a constant pressure from 70 to 100 psi.
7. Turn the pilot regulator screw clockwise until the load rises at the desired speed. Tighten lock screw.

Notice: The up and down speed should be the same for ease of adjustment.

CAUTION
The auxiliary flow valve is fully open when 1/8" of screw head protrudes from regulator body. Do not open beyond this point.

8. Rotate the auxiliary flow control screw counter-clockwise until the load lowers at the desired speed.
9. Make sure the adjustment ring on the Servo is turned counter-clockwise. Attach the air tube (6) from the regulator (2) to the servo (1). You should hear air bleeding at the Servo.

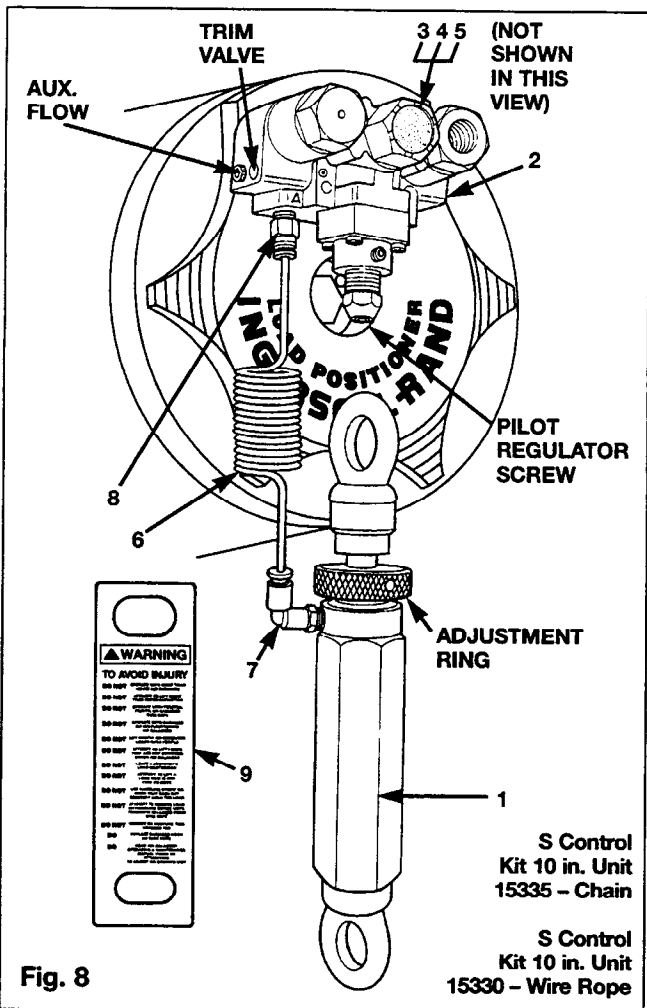

Fig. 8

Item	Part #	Description	Qty.
1	10602	Servo Control	1
2	15601	Integral Regulator Series E	1
3	15781	Screw	2
4	15782	Screw	2
5	15785	Lock Washer	4
6	93948	Coiled Poly Black tube	1
7	93969	Elbow Fitting	1
8	93963	Connector	1
9	10445	Warning Tag (must not be removed)	1

Regulator Installation

Place the unit on a clean, sturdy work surface with the end cap upright. Pull out the wire rope or chain until reel bottoms out. Remove S control kit from package, check to ensure that "O" Ring is in correct position on back of regulator (2). Install the regulator on the end cap with the 4 mounting screws and lock washers (3, 4, 5).

The control kit is supplied with a coil hose assembly (6). Connect coil hose to "A" port of regulator.

(S) Control (Continued)

10. Turn the adjustment ring on the Servo clockwise until the load starts to rise.
11. Turn the adjustment ring counter-clockwise until the load is balanced.
12. Tighten set screw on pilot regulator screw and Servo to maintain adjustment.

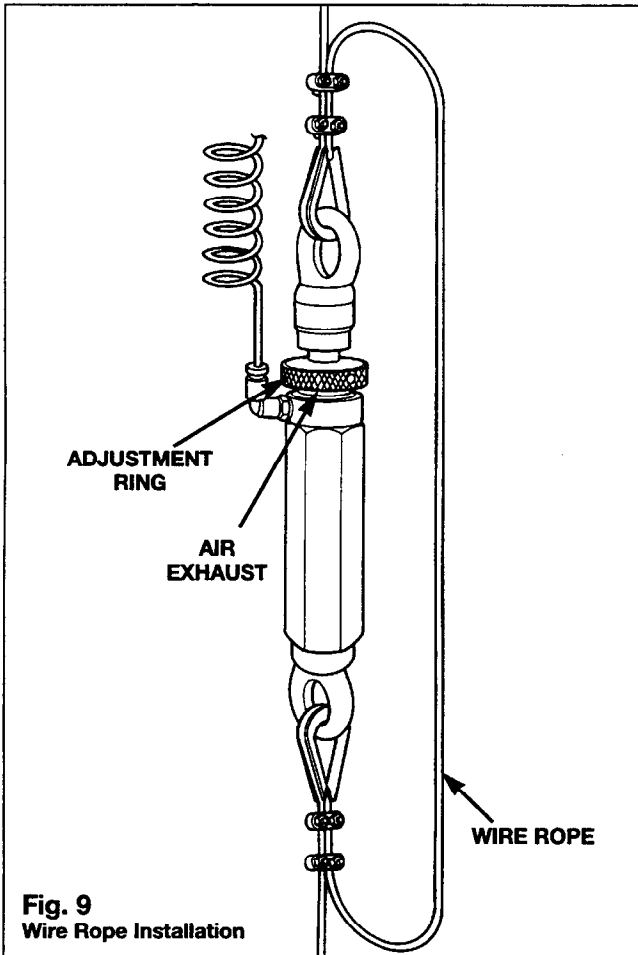

Servo Installation On Wire Rope

1. Mount unit on overhead suspension.
2. Position Servo below travel range of the wire rope.
3. Insert wire rope through top hole in the Servo. Install 2 clamps on wire rope 1-1/2" above top of Servo and 1-1/2" apart. Leave 16" of wire rope free for Servo to operate properly.
4. Insert wire rope through bottom hole in the Servo. Install 2 clamps on wire rope 1-1/2" apart.
5. Install load hook.

Notice: You must leave enough slack in the wire rope to allow proper operation of the Servo unit.

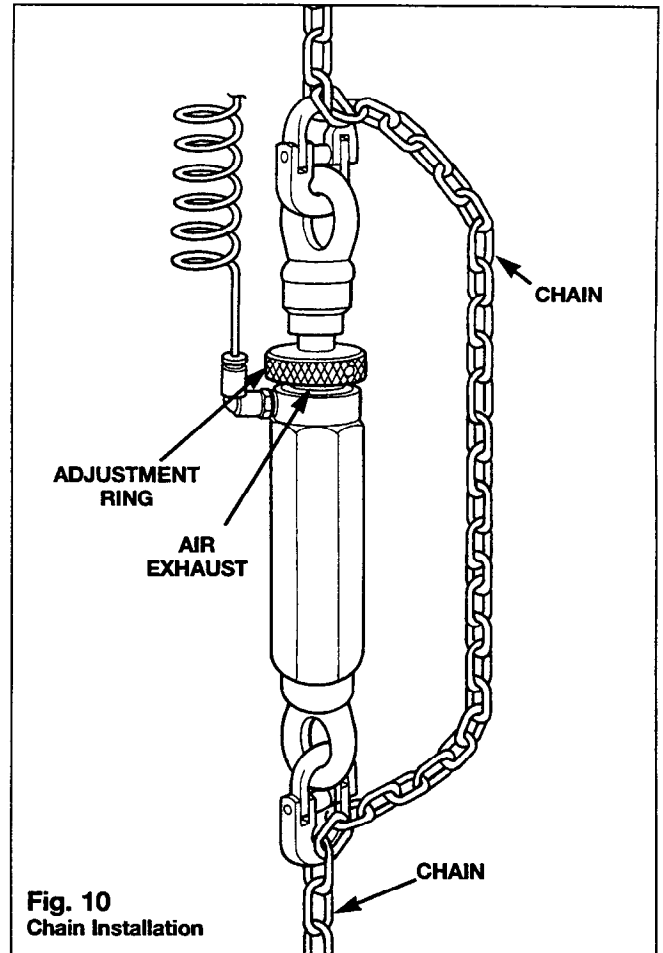

Servo Chain Installation

1. Mount unit on overhead suspension.
2. Position Servo below travel range of the chain.
3. Attach chain to U-Bolt and Servo.

Notice: Do Not Cut Chain.

4. Count 25 links of chain 15.75 inches.
5. Attach 26th link to bottom U-Bolt and Servo.
6. Measure length of chain needed below Servo to determine chain length.
7. Cut chain to desired length.
8. Connect chain to load hook.

(S) Control (Continued)

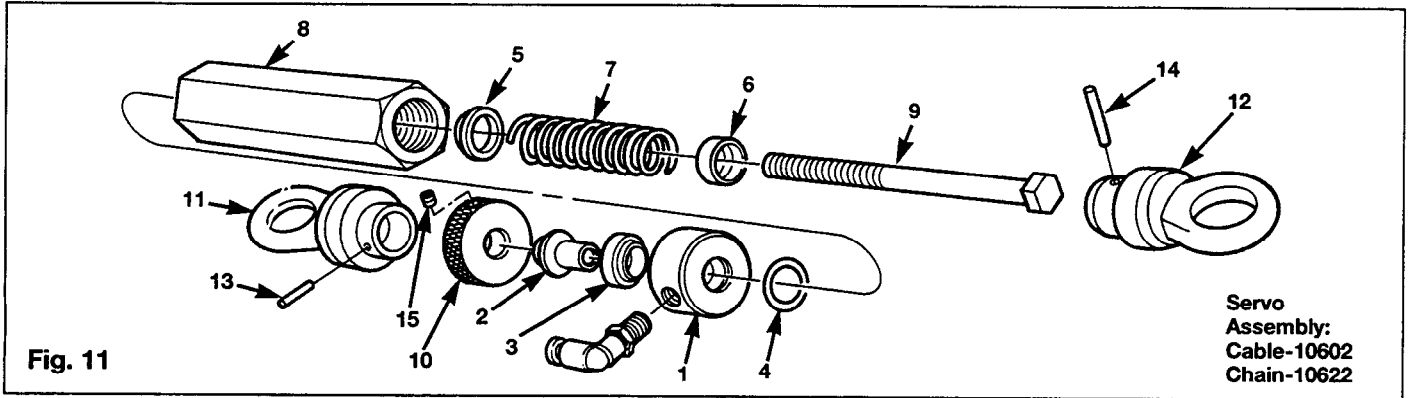

The regulator is the primary control for the S Control system. The Servo bleeds off air. Therefore it works like an amplifier. If the pilot regulator must be readjusted for any reason, the auxiliary flow, trim valve and Servo must be readjusted.

Removal From Unit

1. Place suitable stand or platform under the suspended load. The stand or platform should be high enough for the load to rest on when the unit is at the bottom of its travel.
2. Slowly turn pilot regulator screw counter-clockwise until wire rope is slack. Remove the load, and load hook from wire rope.
3. Turn off air supply.
4. Disconnect control hose from Servo control. Remove wire rope clamps at top and bottom of Servo control to complete removal of control. (See Page 27 to repair regulator).

Reassembly

1. Slide washer (6) (flat side up) onto plunger (9). Slide spring (7) and washer (5) onto plunger (9). Insert this assembly into housing (8).
2. Apply a light coat of lubricant (10886) to "O" Ring (4) and insert in valve groove (1).
3. Install seal (3) on valve stem (2), with the flat side of seal against the shoulder of the stem. Insert it into the valve (1). Slide this assembly onto plunger (9).
4. Thread adjusting nut (10) onto the plunger (9), grooved side first. Tighten to allow cap (11) to be started. Install pin (13).
5. Tighten nut (12). Align hole in nut with hole in housing.
6. Insert roll pin (14).
7. Tighten adjusting nut (10). The control is now ready for installation to the unit unit. (Refer to Servo installation pg. 18.)

Disassembly Refer to Fig. 11.

CAUTION
Use of replacement parts other than genuine Ingersoll-Rand original parts could result in damage to the Unit and void the Warranty.

1. Remove spring pin (13).
2. Remove cap (11).
3. Loosen set screw (15) and remove knurled adjusting nut (10).
4. Slide valve (2) and body (1) from bolt. Remove valve from body and check seal (3) and "O" Ring (4) for deforming or wear.

Notice: Step 5 is performed only if breakage of spring (7) is suspected.

5. Remove pin (14) and nut (12). This permits removal of plunger (9) and spring (7).

Item	Part #	Description	Qty.
1	10626	Valve	1
2	10631	Valve Stem	1
3	*10632	Seal	1
4	*10635	"O" Ring	1
5	10613	Guide Washer	1
6	10614	Load Washer	1
7	10642	Spring	1
8	10645	Housing	1
9	10651	Plunger	1
10	10620	Adjusting Nut	1
11	10628	Cap	1
12	10662	Nut	1
13	*10616	Spring Pin	1
14	*10617	Spring Pin	1
15	*10619	Set Screw	1

SUGGESTED SPARE PARTS AVAILABLE IN KIT
***10600 – SERVO REPAIR KIT**

(S) Control Troubleshooting Guide



CAUTION

Before doing any disassembly, lower load, turn control knob (counter-clockwise) until wire rope is slack. Prior to performing additional adjustments or servicing make sure air supply is off.

PROBLEM	POSSIBLE CAUSE	SOLUTION
<p>Unit will not balance or lift load - no air bleeding from the Servo control.</p>	<ol style="list-style-type: none"> 1. Load over capacity of unit. 2. No air supply to unit. 3. Air supply check valve holding. 4. Pilot regulator pressure set low. 5. Trim valve closed. 6. Filter assembly plugged. 7. Pilot regulator contaminated with oil, water or dirt. 8. Air blowing from inside of unit. 9. Leakage in control line. 10. Air leaking around end bolt. 11. Air leaking around O.D. of end cap. 12. Thrust bearing, worn or tight. Will not rotate. 13. Reel and nut assembly do not turn. 	<ol style="list-style-type: none"> 1. Check weight of load. 100 psi is required to operate unit at maximum capacity. 2. Turn on air. Set line regulator between 70 psi minimum and maximum 100 psi. 3. Low air pressure (should be 70 psi minimum). 4. Adjust until load rises or is in balance. 5. Adjust to manual specification. Refer to S Control operational adjustments. 6. Remove and clean or replace. 7. Remove, replace or clean. Check all parts for wear. 8. Piston leaking - install new piston. Clean and lubricate cylinder bore. 9. Replace hose, fittings as require. 10. Replace seal (10061) and tighten end bolt to 100 ft. lb. 11. Replace "O" Ring (15020). 12. Remove ball screw and reel assembly. Replace or free up bearing as required. Lubricate with #10886. 13. Check for rust, dirt, wear, or the lack of lubrication. Clean and lubricate as required.
<p>Unit will not balance or lower the load.</p>	<ol style="list-style-type: none"> 1. Air supply check valve holding. 2. Excessive air flow through trim valve. 3. Air does not bleed from control line fitting at port "A" of regulator. 4. Foreign matter in fittings at regulator or Servo. 5. Control line pinched or has air flow restriction. 	<ol style="list-style-type: none"> 1. Low air pressure - adjust to 70 psi minimum and 100 psi maximum. 2. Close trim valve (clockwise) slowly until load floats down. 3. Auxiliary flow control valve closed. 4. Remove and check for blockage. 5. Make sure control line is unobstructed so air can flow.

(S) Control Troubleshooting Guide (Continued)

PROBLEM	POSSIBLE CAUSE	SOLUTION
Unit will not balance or lift load - air bleeding from top of Servo.	<ol style="list-style-type: none"> 1. Servo not adjusted properly at adjustment ring. 2. Worn seal on Servo. 3. Worn "O" Ring on Servo. 4. Defective regulator. 	<ol style="list-style-type: none"> 1. Adjust - tighten adjusting nut (10620). 2. Replace seal. 3. Replace "O" Ring. 4. Replace regulator - return to shop for repair.
Erratic operation	<ol style="list-style-type: none"> 1. Fluctuating air supply pressure. 2. Air contaminated with water, oil, dirt, etc. 3. Trim valve not open enough. 4. Defective regulator. 	<ol style="list-style-type: none"> 1. Install pressure regulator in supply line. Set at 70 psi minimum. Do not exceed 100 psi. 2. Install 5 micron self-straining type filter. 3. Rotate trim valve counter-clockwise in 1/4" turn increments until operation is smooth. 4. Replace regulator repair as necessary. Ref. Regulator disassembly.
Load hard to pull down	<ol style="list-style-type: none"> 1. Servo adjustment ring too tight. 2. Trim valve open too much. 3. Wire rope does not have enough slack - holding Servo closed. 4. Auxiliary flow control valve closed too much. 	<ol style="list-style-type: none"> 1. Loosen ring until air flow is evident. 2. Rotate trim valve clockwise in 1/4" turn increments until load is easy to pull down. 3. Perform Servo removal. Loosen bottom wire rope clamp and pull wire rope up. Retighten clamp. 4. Rotate auxiliary flow control counter-clockwise in 1/4" turn increment until load is easy to pull down. <p>CAUTION: The auxiliary flow valve is fully open when 1/8" of screw head protrudes from regulator body. Do not open beyond this point.</p>

(E) Control Basic Unit

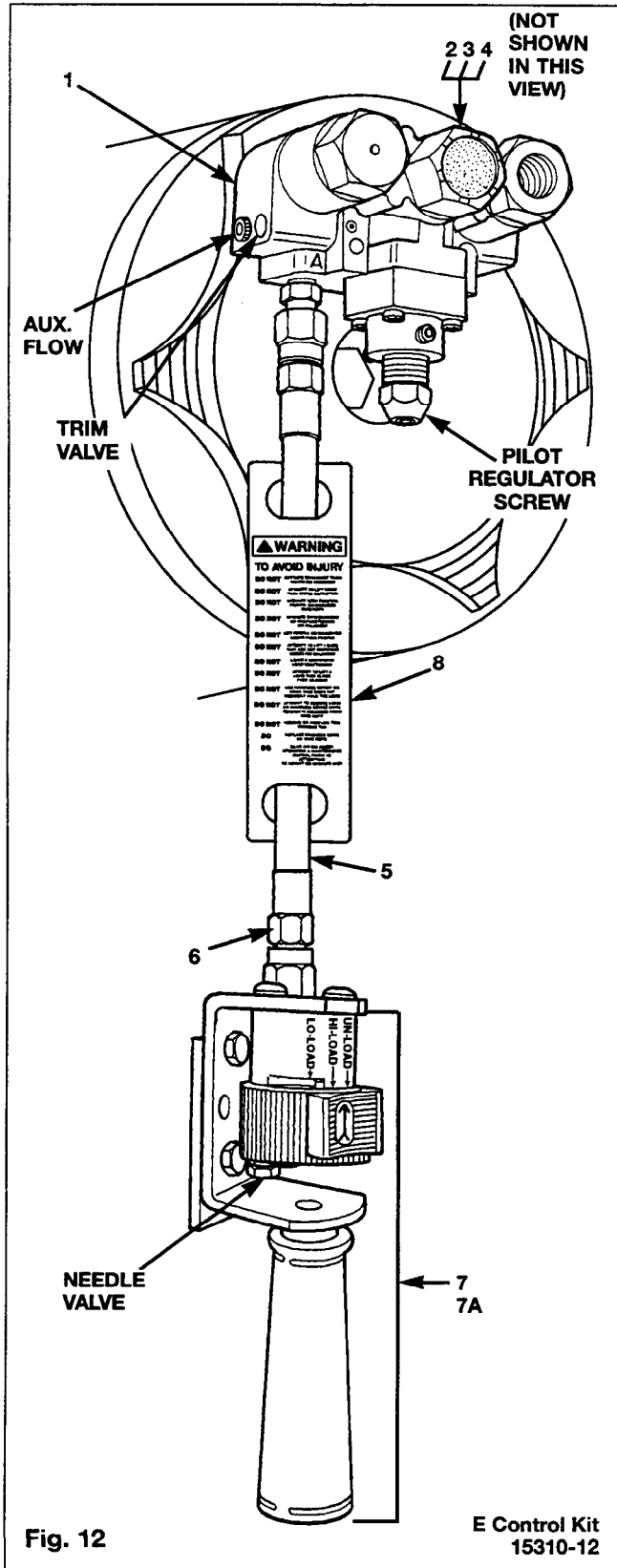

Fig. 12

E Control Kit
15310-12

(E) Regulator Installation Refer to Fig. 12.

Place the unit on a clean, sturdy work surface with the end cap upright. Pull out the wire rope or chain until reel bottoms out. Remove E control kit from package. Check to ensure that "O" Ring is in the port on the back of the regulator (1). Install the regulator on the end cap with the 4 mounting screws and lock washers (2, 3, 4). Connect control hose to port A on regulator and the port on the control handle.

Item	Part #	Description	Qty.
1	15601	Regulator	1
2	15781	Mounting Screw	2
3	15782	Mounting Screw	2
4	15785	Lock Washer	4
5	10249	Black Control Hose	10
6	10261	Swivel Fitting	2
7	01810	Safety E Control Handle Assembly	1
7A	01800	Optional E Control Handle Assembly	2
8	10445	Warning Tag (must not be removed)	1

Operational Adjustments



WARNING

Prior to performing operational adjustments or servicing make sure air supply is off.



WARNING

The Unit may not support the weight of the empty handling device, or may raise device at a potentially hazardous rate. Extreme care must be used until control adjustments are complete.

Notice: You must have a minimum of 70 psi to operate the regulator. Do not use an air line lubricator.

1. Turn the pilot regulator screw counter-clockwise until 1/2" of thread is visible.



CAUTION

The auxiliary flow valve is fully open when 1/8" of screw head protrudes from regulator body. Do not open beyond this point.

2. Adjust the auxiliary flow control screw by rotating clockwise completely and then counter-clockwise 5 full turns, or until the screw head extends from the regulator body 1/8".

(E) Control Basic Unit (Continued)

3. Adjust the trim valve by turning the screw clockwise completely and then turning counter-clockwise 1 turn.
4. Turn both needle valves, located in the control handle, clockwise until fully closed. (Refer to Fig 13, item 3).
5. Attach heaviest load to load hook or handling device.
6. Connect and turn on the air supply. Set supply line regulator so that the unit receives a constant pressure from 70 to 100 psi.
7. Turn the E control handle to the hi-load position. Turn the pilot regulator screw clockwise until the heaviest load floats.
8. Turn the E control handle to the lo-load position. The load should not lower.
9. Turn the lo-load needle valve, located on the handle, counter-clockwise until the load lowers, and wire rope becomes slack.
10. Engage lightest load with load hook or handling device.
11. Rotate lo-load needle valve clockwise until lightest load floats.
12. Rotate E handle to unload position. The lightest load should drift up.
13. Turn the un-load needle valve, located on the handle, counter-clockwise until enough air is exhausted from the unit so that the lightest load lowers and the wire rope becomes slack.
14. Remove lightest load from load hook or handling device.
15. Rotate the un-load needle valve clockwise until the empty handling device begins to float.
16. Rotate control valve to the three positions. Make sure the unit works properly. Some fine tuning might have to be done.

Notice: *If, for any reason, the pilot regulator must be readjusted, these needle valves will have to be adjusted also.*

Removal From Unit Refer to Fig. 12.

1. Place suitable stand or platform under the suspended load. The stand or platform should be high enough for the load to rest on when the unit is at the bottom of its travel.
2. Slowly turn pilot regulator screw counter-clockwise. This will release the tension on the wire rope for load removal.
3. Turn off air supply.
4. Disconnect control hose (5) from the E Handle. (see page 27 to repair regulator).

Disassembly Refer to Fig. 13.



CAUTION

Use of replacement parts other than genuine Ingersoll-Rand original parts could result in damage to the Unit and void the Warranty.

1. Remove the two screws (17). Remove rotor control valve assembly (01851) or (01850) from the bracket (18).
2. Drive out roll pin (16).
3. Remove bolt (15), be cautious these are spring loaded parts.
4. Remove and replace any worn or broken parts in the rotor valve (2) or (2A).
5. Remove floating seal assembly (11), spring (13), ball detent (9) and spring (10).
6. Inspect seal (11) and "O" Ring (12) for wear. The face of the seal should be smooth. If it is not, polish the seal on crocus cloth. The "O" Ring (12) must be free of nicks and cuts. Replace all worn parts.
7. Remove and inspect the two needle valves (3) for damage to their tapered tips. Replace damaged valves.

(E) Control Handle

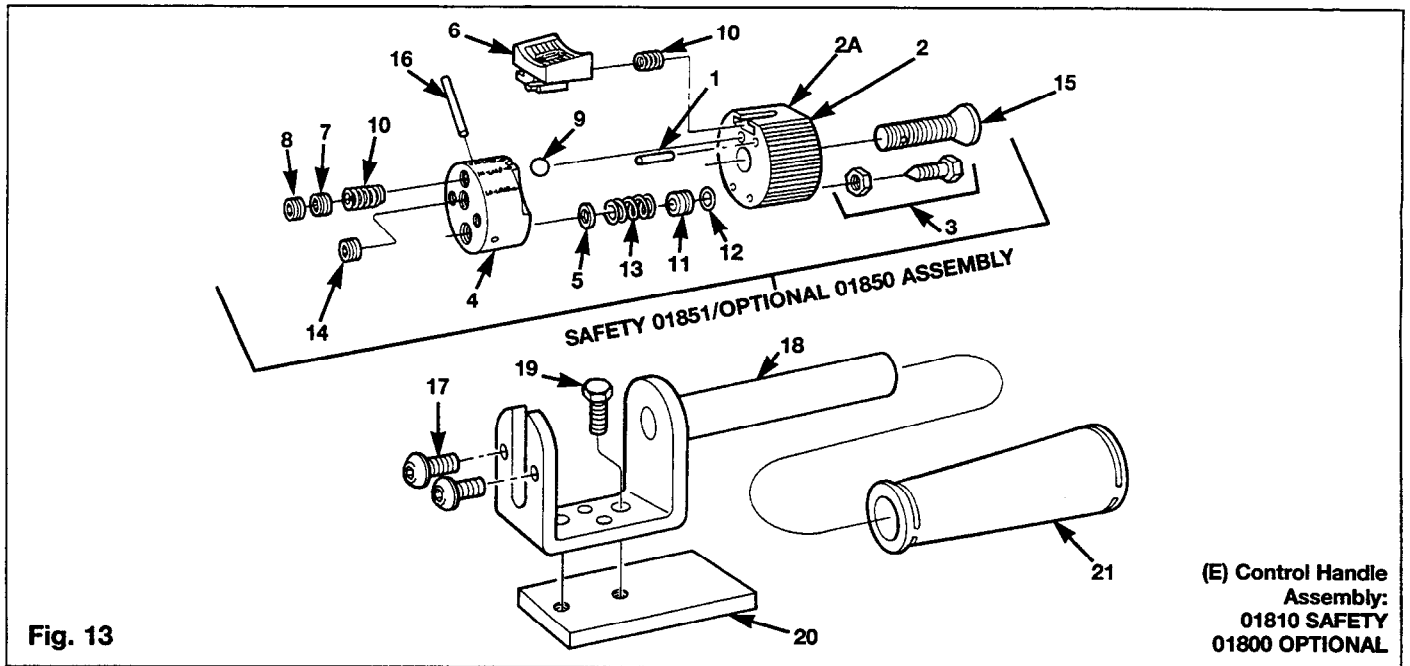

Fig. 13

(E) Control Handle
Assembly:
01810 SAFETY
01800 OPTIONAL

Item	Part #	Description	Qty.
1	*01807	Spring Pin, Control Valve	1
2	01862	Valve Rotor, Optional E	1
2A	01863	Valve Rotor, Safety E	1
3	*01838	Needle Valve Assembly	2
4	01860	Valve Body Option & Safety	1
5	*01886	Brass Washer	1
6	*01804	Thumb Well Locator	1
7	01803	Soc. Set Screw	1
8	01834	Soc. Set Screw	1
9	*01805	Detent Ball	1
10	*01806	Detent Spring	2
11	*01880	Floating Seal	1
12	*01882	"O" Ring	1
13	*01884	Seal Spring	1
14	01801	Soc. Set Screw	1
15	01817	Soc. Flt. Hd. Screw	1
16	*01814	Spring Pin	1
17	10070	Button Head Screw	2
18	01840	Handle Bracket	1
19	01833	Hex Head Screw	2
20	01826	Mounting Block	1
21	18447	Handle Grip	1

SUGGESTED SPARE PARTS AVAILABLE IN KIT
* 01813 - (E) CONTROL HANDLE REPAIR KIT

Reassembly

1. If pin (1) has been removed, reinstall it into the 1/8" hole in the rotor (2) or (2A). The pin must protrude 3/32" above surface.
2. Install screw (7), spring (10) and ball detent (9) in small hole in valve body.
3. Insert washer (5), spring (13) and floating seal (11) with "O" Ring (12) into the large hole in the valve body (4). Apply a small amount of lubricant to the "O" Ring (12).
4. For rotor (2A) only, insert spring (10) and locator (6) in slot in rotor valve. Locator should slide in and out freely. Apply small amount of light grease in slot if necessary.

Notice: If new bolt (15) is installed, it must be drilled to accept pin (16).

5. Insert bolt (15) through rotor. Mate this assembly with the valve body assembly. Tighten bolt until hole in bolt is aligned with hole in body.
6. Insert pin (16).
7. Thread two needle valves (3) into rotor body.
8. Adjust screw (7) to give proper detent feel to rotor.
9. Install and tighten set screw (8).
10. Install and tighten screw set (14).
11. Attach rotor control valve assembly (2) or (2A) to handle bracket (18).
12. Reinstall to control hose. (Refer to E Basic Installation.)
13. Perform E Basic Operational Adjustments.

(E) Control Troubleshooting Guide



CAUTION

Before doing any disassembly, lower load, turn control knob (counter-clockwise) until wire rope is slack. Prior to performing additional adjustments or servicing make sure air supply is off.

PROBLEM	POSSIBLE CAUSE	SOLUTION
Unit will not lift load. Control handle in hi-load position.	<ol style="list-style-type: none"> 1. Load over capacity of unit. 2. No air supply to unit. 3. Air supply check valve holding. 4. Pilot regulator pressure set low. 5. Trim valve closed. 6. Filter assembly plugged. 7. Pilot regulator full of oil, water or dirt. 8. Air blowing from inside of unit. 9. Leakage in control line or handle. 10. Air leaking around end cap bolt. 11. Air leaking around O.D. of end cap. 12. Thrust bearing, worn or tight, will not rotate. 13. Reel and ball nut assembly do not turn. 	<ol style="list-style-type: none"> 1. Check weight of load including handling device. 100 psi is required to operate unit at maximum capacity. 2. Turn on air. Set line regulator at maximum maintainable pressure not to exceed 100 psi. 3. Low air pressure (should be 70 psi minimum). 4. Adjust until load rises. 5. Adjust to manual specification. Pg. 23. 6. Remove and clean or replace. 7. Remove, replace or clean. Check all parts for wear. Replace worn items. 8. Piston leaking - install new piston. Clean and lubricate cylinder bore. 9. Replace hose, fittings or handle parts as required. 10. Replace seal (10061) and tighten end cap bolt to 100 ft. lb. 11. Replace "O" Ring (15020) or (15520). 12. Remove ball screw and reel assembly. Replace or free up bearing as required. Lubricate with P/N 10886. 13. Check for rust, dirt, wear, or the lack of lubrication. Clean and lubricate as required.

(E) Control Troubleshooting Guide (Continued)

PROBLEM	POSSIBLE CAUSE	SOLUTION
<p>Unit will not balance or lower the load. Control handle in lo-load position.</p>	<ol style="list-style-type: none"> 1. Lo-load needle valve closed. 2. Air supply check valve holding. 3. Excessive air flow through trim valve. 4. Air does not bleed from control line fitting at "A" port of the regulator. 5. Control line pinched or has air flow restriction. 6. Foreign matter in fittings at the regulator, handle, or bleed parts in handle. 	<ol style="list-style-type: none"> 1. Refer to E Basic Operational Adjustments. 2. Low air pressure - should be 70 psi, minimum. 3. Close trim valve (clockwise) slowly. 4. Refer to E Basic Operational Adjustments, Trim Valve and Auxiliary Flow Valve Settings. 5. Make sure control line is unobstructed so air can flow. 6. Make sure air passages are open for air flow.
<p>Unit will not un-load. Control handle in un-load position.</p>	<ol style="list-style-type: none"> 1. Air supply check valve holding. 2. Un-load needle valve closed. 3. Excessive air flow through trim valve. 4. Foreign matter in fittings at regulator, handle, or bleed parts in handle. 	<ol style="list-style-type: none"> 1. Check for sufficient air supply pressure, 70 psi minimum. 2. Open needle valve slowly. 3. Close trim valve (clockwise) slowly until empty hook is balanced. 4. Make sure air passages are open for air flow.
<p>Erratic Operation</p>	<ol style="list-style-type: none"> 1. Fluctuating air supply pressure. 2. Air contaminated with water, oil, dirt, etc. 3. Defective regulator. 	<ol style="list-style-type: none"> 1. Install pressure regulator in supply line. Set at low end of pressure fluctuation. Do not exceed 100 psi. 2. Install 5 micron self-draining type filters. 3. Replace regulator or repair as necessary. Refer to Regulator disassembly.

(E) Control and (S) Control 10 in. Unit Regulator

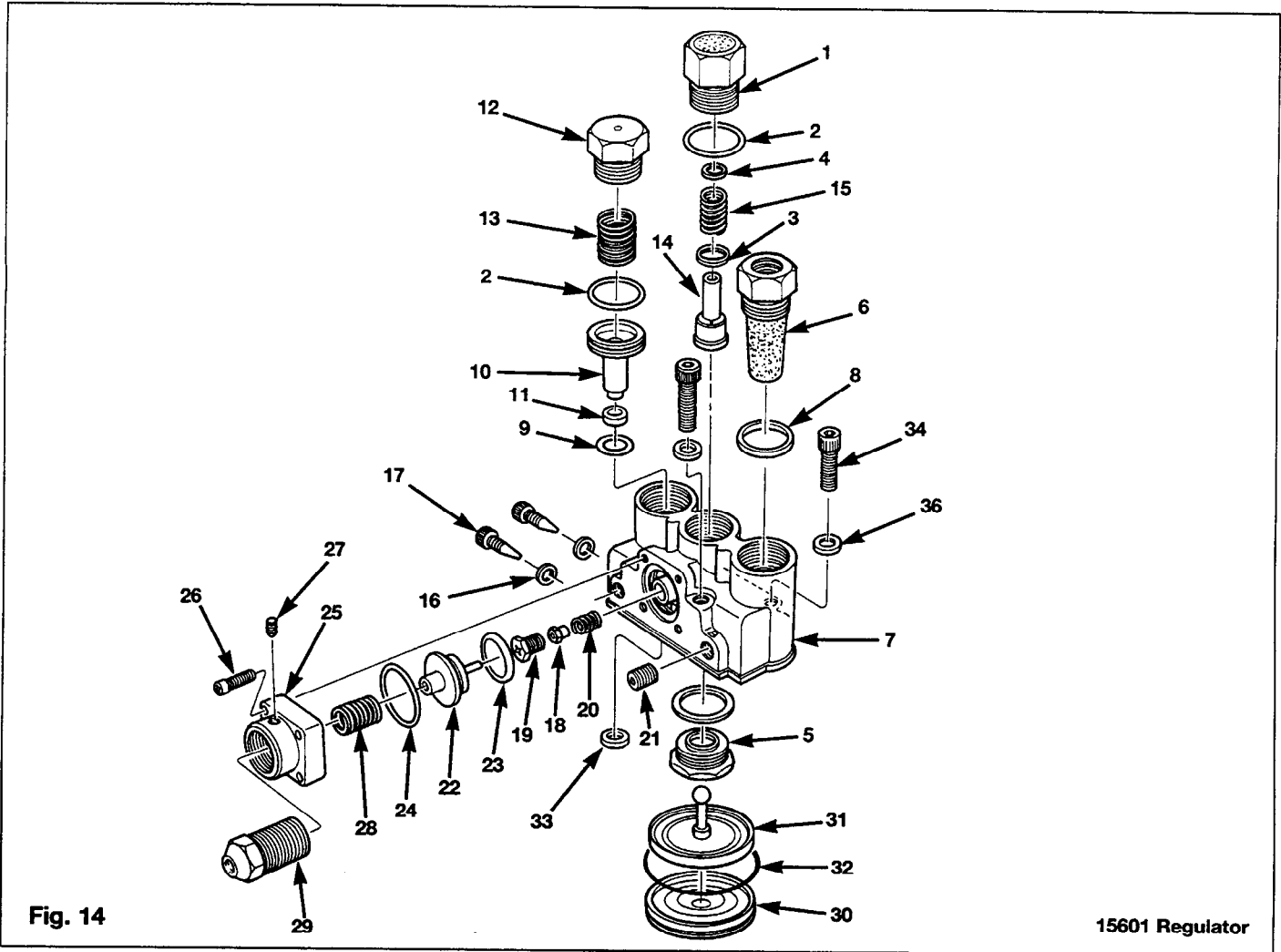

Fig. 14

15601 Regulator

Item	Part #	Description	Qty.
1	15692	Guide Assembly - Regulator	1
2	*15750	"O" Ring	3
3	*15754	"O" Ring	1
4	*15755	"O" Ring	1
5	15670	Valve Seat - Regulator	1
6	13062	Intake Filter Assembly	1
7	15605	Body Assembly - Regulator	1
8	*15758	"O" Ring	1
9	*15759	"O" Ring	1
10	15730	Fail Safe Piston - Regulator	1
11	*15740	Fail Safe Seal - Integral Check	1
12	15710	Fail Safe Plug - Regulator	1
13	15720	Fail Safe Spring - Regulator	1
14	*15680	Valve Stem - Regulator	1
15	15700	Stem Spring - Regulator	1
16	*15748	"O" Ring	2
17	15760	Needle Valve - Regulator	2
18	*15802	Valve Assembly	1

Item	Part #	Description	Qty.
19	*15803	Valve Seat	1
20	*15804	Valve Spring	1
21	13500	Pipe Plug	1
22	*15800	Pilot Piston Assembly	1
23	*15801	U-Cup Seal	1
24	*15757	"O" Ring	1
25	15821	Pilot Bonnet - Regulator	1
26	15777	Self Tap Screw	4
27	10619	Set Screw	1
28	15810	Pilot Spring	1
29	15841	Regulator Screw Assy - Reg.	1
30	15620	Bonnet - Regulator	1
31	*15630	Main Diaphragm Assy - Reg.	1
32	*15752	"O" Ring	1
33	*15751	"O" Ring	1
34	15782	Screw	2
35	15781	Screw	2
36	15785	Lock Washer	4

SUGGESTED SPARE PARTS AVAILABLE IN KIT
***15900 - REGULATOR REPAIR KIT**

(E) Control and (S) Control 10 in. Unit Regulator (Continued)

Removal From Unit

1. Place suitable stand or platform under the suspended load. The stand or platform should be high enough for the load to rest on when the unit is at the bottom of its travel.
2. Slowly turn pilot regulator screw counter-clockwise until the wire rope is slack. Remove load from hook.
3. Turn off air supply.
4. Disconnect all hose connections from the regulator.
5. Remove mounting screws.

Disassembly Refer to Fig. 14.



CAUTION

Use of replacement parts other than genuine Ingersoll-Rand original parts could result in damage to the Unit and void the Warranty.

1. Remove filter assembly (6). Check for dirt or loose filter media.
2. Remove check valve assembly by removing plug (12) and pushing piston (10) out from opposite side with a blunt punch. The assembly consists of the hexagon plug (12), spring (13) and piston (10), "O" Rings (2), (9) and seal (11). Inspect check valve "O" Ring (2), seal (11), and piston "O" Ring (9) for wear.
3. Remove the guide assembly (1). This consists of three different size "O" Rings (2), (3) and (4), a valve stem (14) and spring (15). Two "O" Rings (2) are located inside the guide assembly. Check "O" Rings and valve stem for wear. Check inside the valve for possible clogging of small pressure balance hole.
4. To remove the bonnet (30) and diaphragm (31), push on brass ball, visible through the hole in the valve seat (5), with an instrument softer than brass.
5. Check the rubber diaphragm for cracks or cuts. Replace it if necessary. Make sure the brass ball pin is free to rotate.

Notice: The brass ball pin must not have end play. If end play is found, adjust the set screw on the opposite side of the diaphragm. Apply a light coat of thread-locking compound to prevent the screw from turning. End play in the pin will cause slow exhaust or erratic operation.

6. Remove the four screws (26) from pilot regulator bonnet (25).
7. Remove the pilot piston assembly (22). Check U-cup (23) and "O" Ring (24) for wear.
8. Check opening in brass tube of piston assembly (22) to make sure it is clear.
9. To inspect valve assembly (18), valve seat (19) and spring (20), remove seat with a #2 phillips screwdriver or 3/8" socket wrench. Check rubber insert on valve (18) for wear. Replace if necessary.
10. Remove trim valve (17) and "O" Ring (16). Check "O" Ring for wear and trim valve tip for possible damage.
11. Remove auxiliary flow control valve (17) and "O" Ring (16). Check "O" Ring for wear and valve tip for possible damage.
12. Clean regulator body (7) and components thoroughly. Replace all worn parts.

Notice: If more than 2 or 3 items require replacement, it is generally advisable to thoroughly clean the regulator and install a P/N 15900 repair kit.

Reassembly

1. Apply a very light coat of lubricant (10886) to all "O" Rings during reassembly.
2. Install auxiliary flow control valve (17) and "O" Ring (16). Turn until head of valve protrudes 1/16" to 1/8" from regulator body.
3. Install trim valve (17) and "O" ring (16). Turn clockwise until closed.
4. Install pilot regulator components. Insert spring (20) into hole. Position valve (18) in place. Make sure rubber insert of valve faces away from spring.
5. Insert valve seat (19) and carefully tighten.
6. Insert "O" Rings (4) and (3) into guide. Apply a light coat of lubricant (10886) on O.D. of valve stem (14). Slide spring (15) over the small end of the valve stem. Insert this assembly into guide assembly (1). Place completed guide and valve assembly into the center hole of the regulator body (7) and tighten.
7. Insert filter assembly (6) into hole above port B and tighten.
8. Insert the stem of the check valve assembly (10) seal end first into hole above port A. Insert spring (13) and hexagon plug (12).

(E) Control and (S) Control 10 in. Unit Regulator (Continued)

9. Place "O" Ring (24) into groove in regulator body between ports A & B. Insert spring (28) into regulator screw (29). Lubricate U-cup (23) with lubricant (10886). Insert it with piston assembly (22) into pilot regulator bonnet (25). Make sure brass stem goes through center of valve seat (19).
10. Insert and tighten the four screws (26). This completes the pilot regulator assembly.
11. Connect air supply to regulator and turn on.
12. Check pilot regulator operation by turning regulator screw (29) clockwise until air pressure flows through the small hole located on the back of the regulator body, at the edge of bonnet (30) opening.

Notice: After checking for air flow, turn adjustment knob counter-clockwise until air flow stops. Disconnect air supply.

13. Insert diaphragm assembly (31), bonnet (30) and "O" Ring (33).

Tandem Control Unit

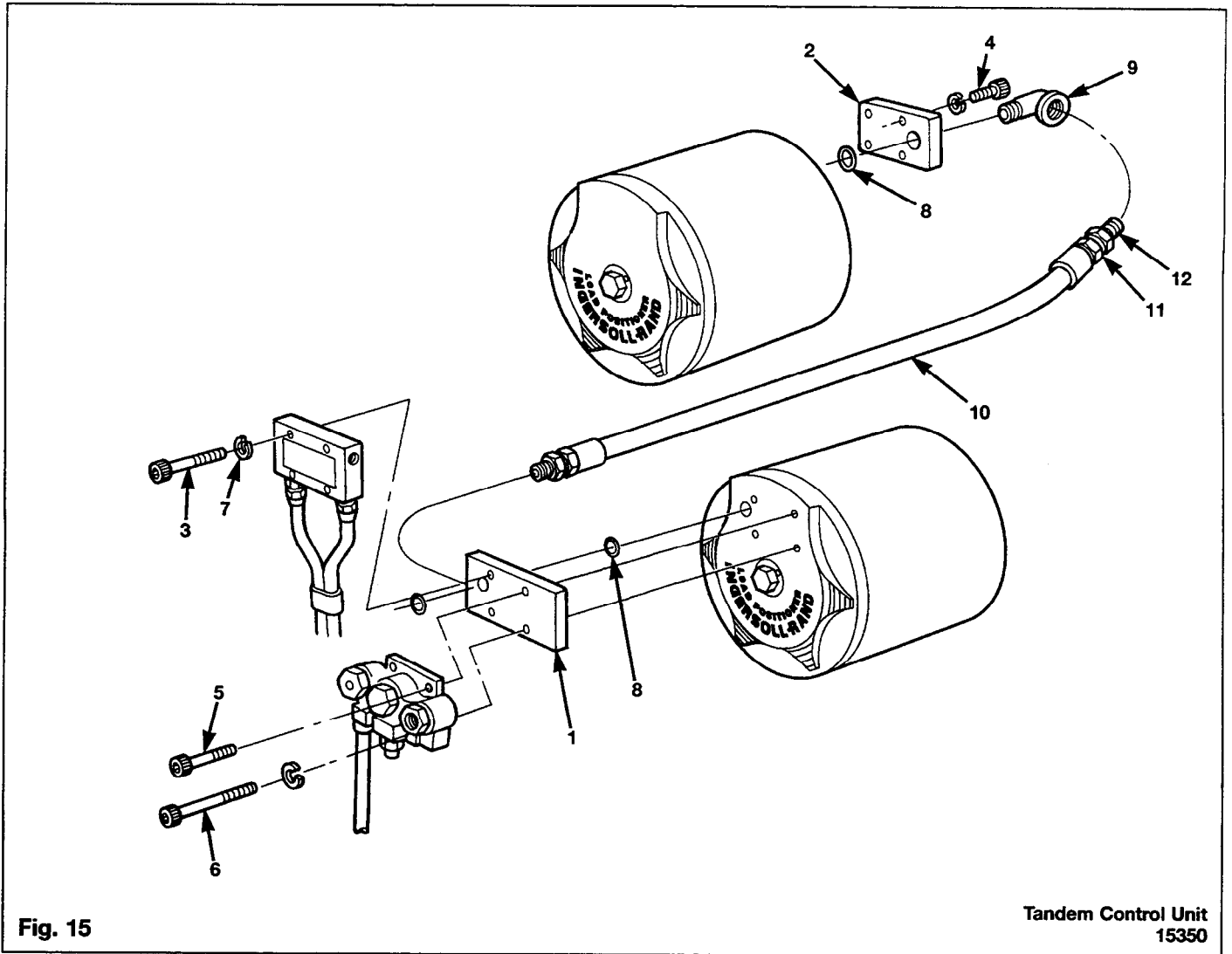

Fig. 15

Tandem Control Unit
15350

Tandem Control Installation

1. Install master manifold (1) behind (E), (P) or (S) control kit, as shown in illustration.
2. Install slave manifold (2) to 2nd unit.
3. Install tandem hose assembly (10) between master (1) and slave (2) manifolds as shown in figure 15.

Item	Part #	Description	Qty.
1	15094	Master Tandem Manifold	1
2	15093	Slave Tandem Manifold	1
3	15778	Mounting Screw	4
4	15779	Mounting Screw	4
5	15786	Mounting Screw	2
6	15787	Mounting Screw	2
7	15785	Lock Washer	8
8	15751	"O" Ring	2
9	10375	Street Elbow. 90	2
10	10555-B	Black Control Hose	2.5 ft
11	10560	Swivel-F Hose Fitting	2
12	10565	Male Adapter	2

Load Hook Lash-up and Yarding

Lash-Up

To properly install the load hook to wire rope or chain you must determine the following:

1. Highest point which load must clear from floor. (Ref. Fig. 16).
2. Distance from hook throat to bottom of load. (Ref. Fig. 17).
3. Add number 1 dimension to number 2 dimension, then add 3-1/2".
4. Measuring from the floor with the wire rope fully retracted, install hook using the dimension from number 3 to the floor.

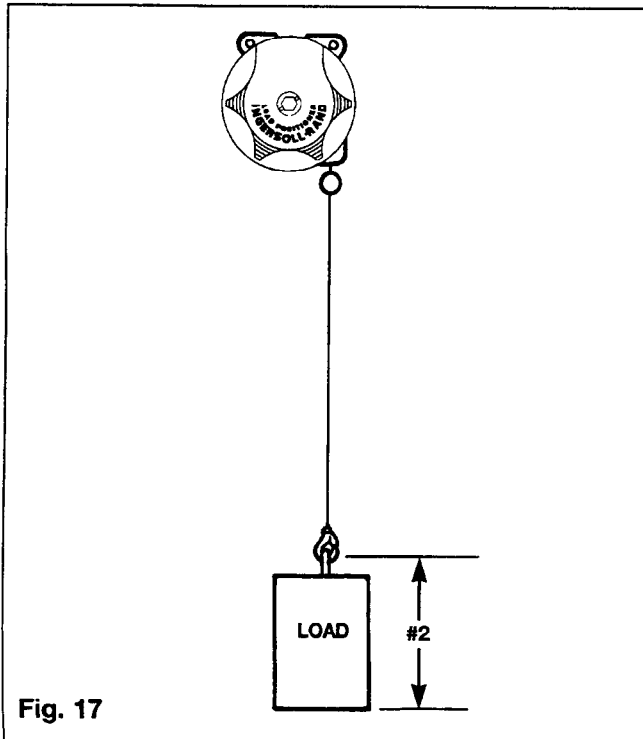
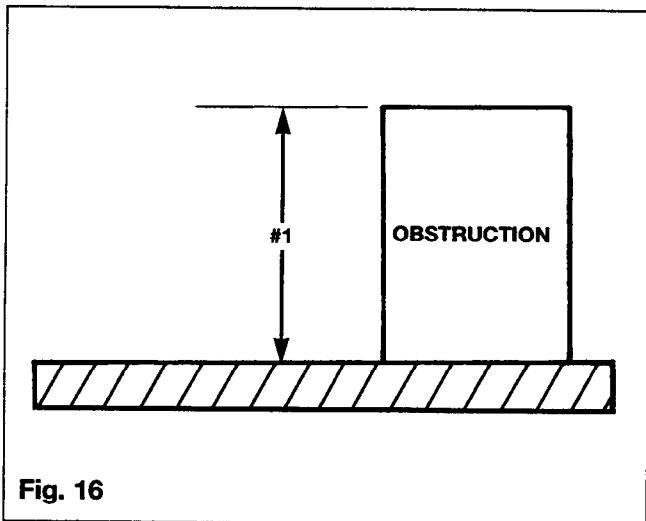

! CAUTION
Do not operate the unit if load is not centered under wire rope. Yarding of the wire rope will cause premature wire rope failure and undue wear of internal unit parts and may void warranty.

Yarding

The chain or wire rope should not be yarded more than 10 degrees from the center line of the chain/wire rope guide.

Excessive yarding will cause increased wear on the unit and decrease the working life of the components.

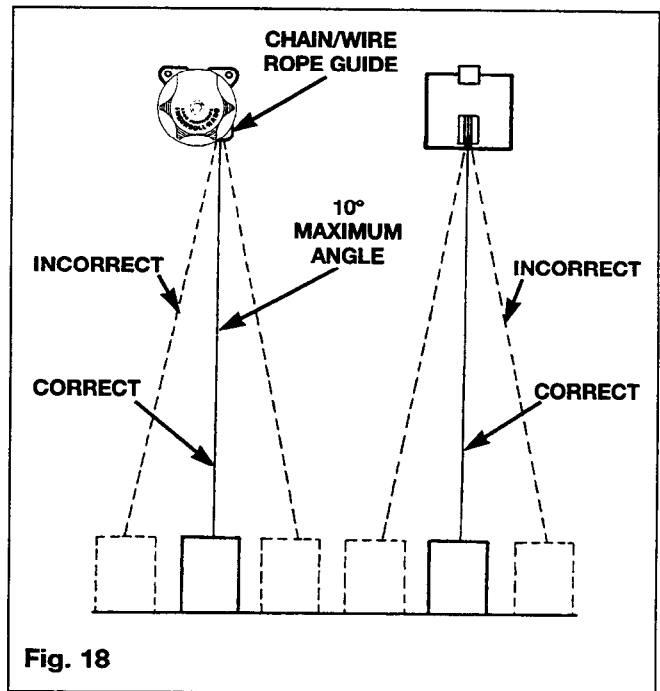

Load Hooks

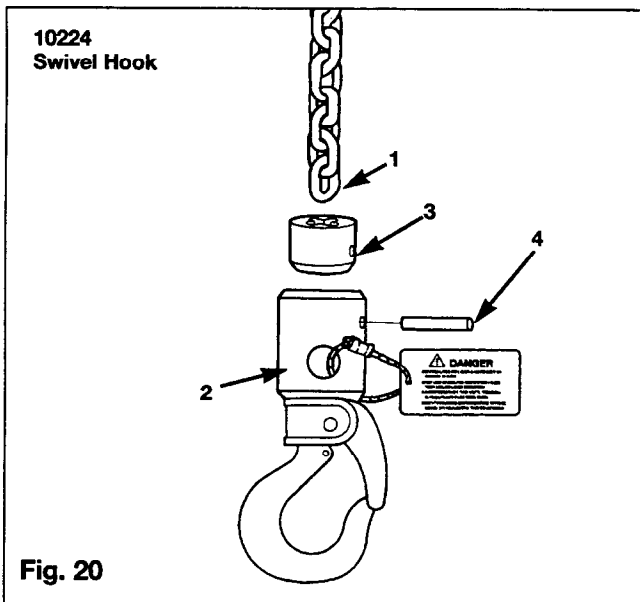
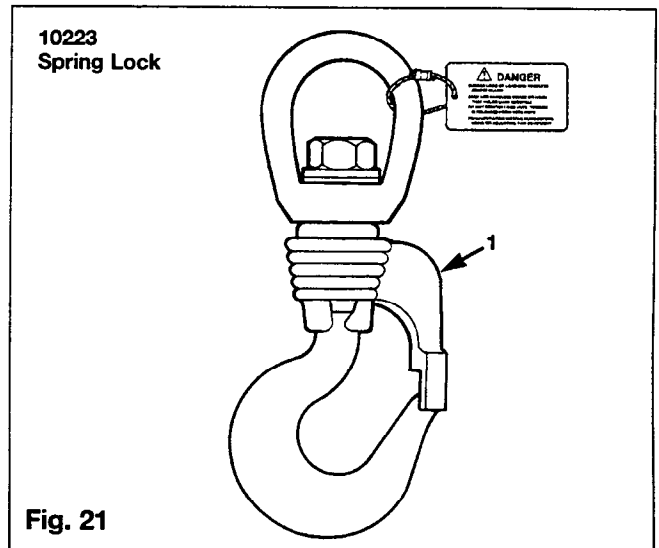
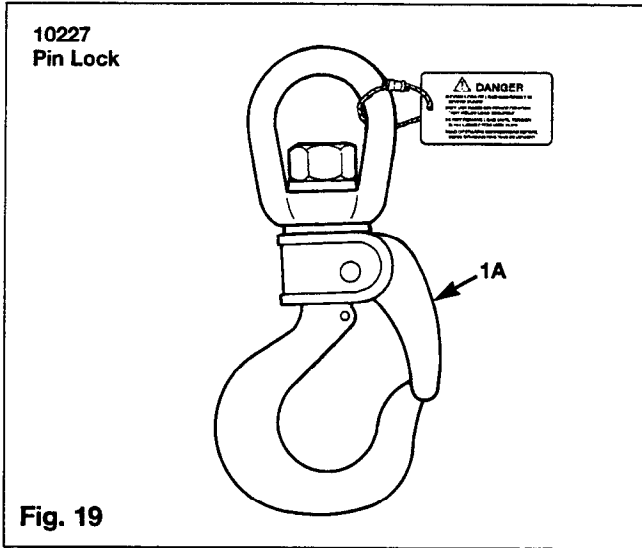

Item	Part #	Description	Qty.
1	10109-20	Chain, 20 ft. length	1
2	10224	Chain Hook	1
3	42207	Plug	1
4	77045	Pin	1

Chain To Hook Assembly

Insert chain in slot in plug (3). Insert chain and plug combination into chain hook (2). With all parts together be sure that pin holes in the plug and hook are in line. In addition, make sure that chain is positioned in slot with sufficient depth to allow pin to pass through last link of chain. Press pin (4) into assembly to connect chain to chain hook.

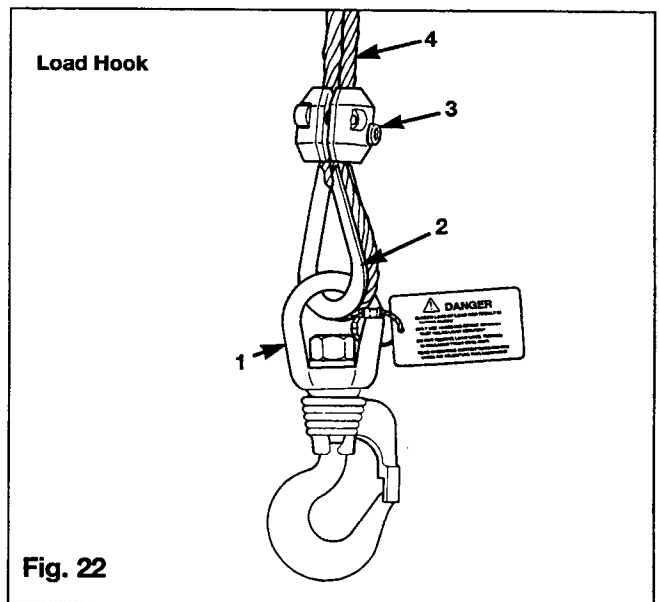

Item	Part #	Description	Qty.
1	10223	Hook Assy., Spring Lock	1
1A	10227	Hook Assy., Pin Lock	1
2	10210	Thimble	1
3	10237	Clamp	1
4	10084-30	Wire rope, 30 ft. length	1

Wire Rope To Hook Assembly

Spread and insert thimble (2) to clamp loop. Thread wire rope around thimble.

Notice: Allow at least 1" of excess wire rope. Join live wire rope strand to excess and install clamp as shown in illustration.



CAUTION

Units using load blocks should not have ball stops on wire rope.



CAUTION

Be sure chain is not twisted when routing around pulley in load block. The chain welds should not run on the pulley.

Load Blocks

10202
Load Block
Single Sheave Cable

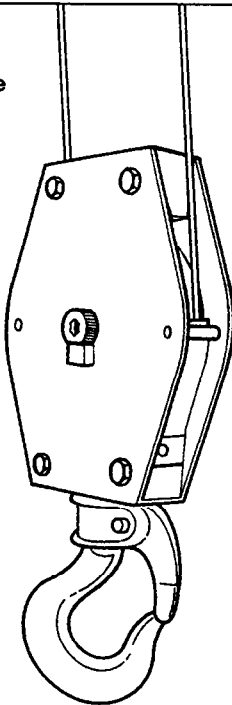

Fig. 23

10203
Load Block
Double Sheave Cable

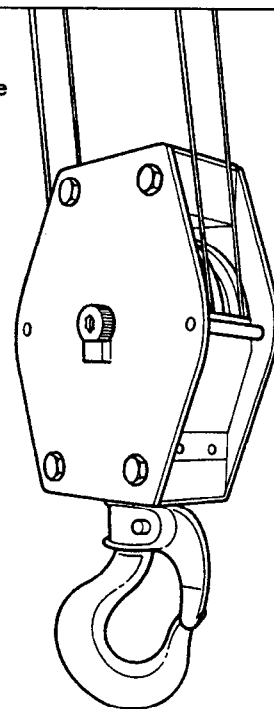
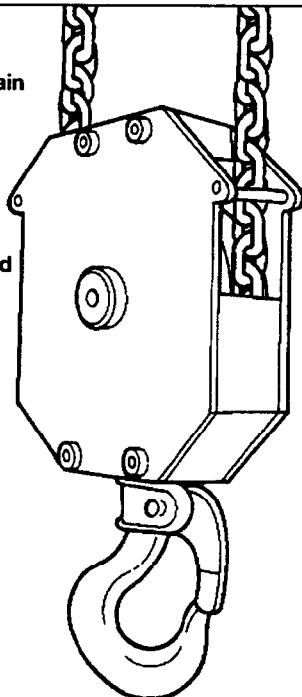

Fig. 25

10580
Load Block
Single Sheave Chain



10217 - Includes
10580 and Eye Pad
Connecting Link

Fig. 24

Load Block Installation (Wire Rope)

1. Thread wire rope through and around pulley(s) in Load Block.
2. Bring excess wire rope back up to bottom eye pad of unit.
3. Install thimble on eye pad.
4. Loop wire rope around thimble.
5. Tighten wire rope and install clamps.

Load Block Installation (Chain)

1. Thread chain around pulley with welds away from pulley surface.
2. Bring excess chain up to bottom of unit eye pad.
3. Install connecting link to chain and eye pad.

**WARNING**

Severe injury and/or property damage may occur if suspension kit is not installed correctly, or if installed on a rail flange other than specified. Rail stops must not contact unit housing.

Part Number	Load Positioner Suspension Kit	Refer To Figure:
16300	ZRS2/3 6.5 in. Unit	30
16305	ZRA1 6.5 in. Unit	26
16307	IRV2 6.5 in. Unit	26
16310	ZRA2 6.5 in. Unit	30
16315	KBK II 6.5 in. Unit	30
16320	T-Rail 6.5 in. Unit	27
16325	KBK I 6.5 in. Unit	31
16344	ETA4 6.5 in. Unit	26
16345	ETA 8 6.5 in. Unit	30
16355	ZRAT 6.5 in. Unit	26
16360	Hook Mount 6.5 in. Unit	29
16380	Opt. 6.5 in. Unit	30
16400	ZRS2/3 10 in. Unit	30
16405	ZRA1 10 in. Unit	28
16407	IRV2 10 in. Unit	28
16410	ZRA2 10 in. Unit	30
16415	KBK II 10 in. Unit	30
16420	T-Rail 10 in. Unit	27
16425	KBK I 10 in. Unit	31
16444	ETA4 10 in. Unit	28
16445	ETA8 10 in. Unit	30
16455	ZRAT 10 in. Unit	28
16460	Hook Mount 10 in. Unit	29
16480	Opt. Mount 10 in. Unit	30

Suspension Kits

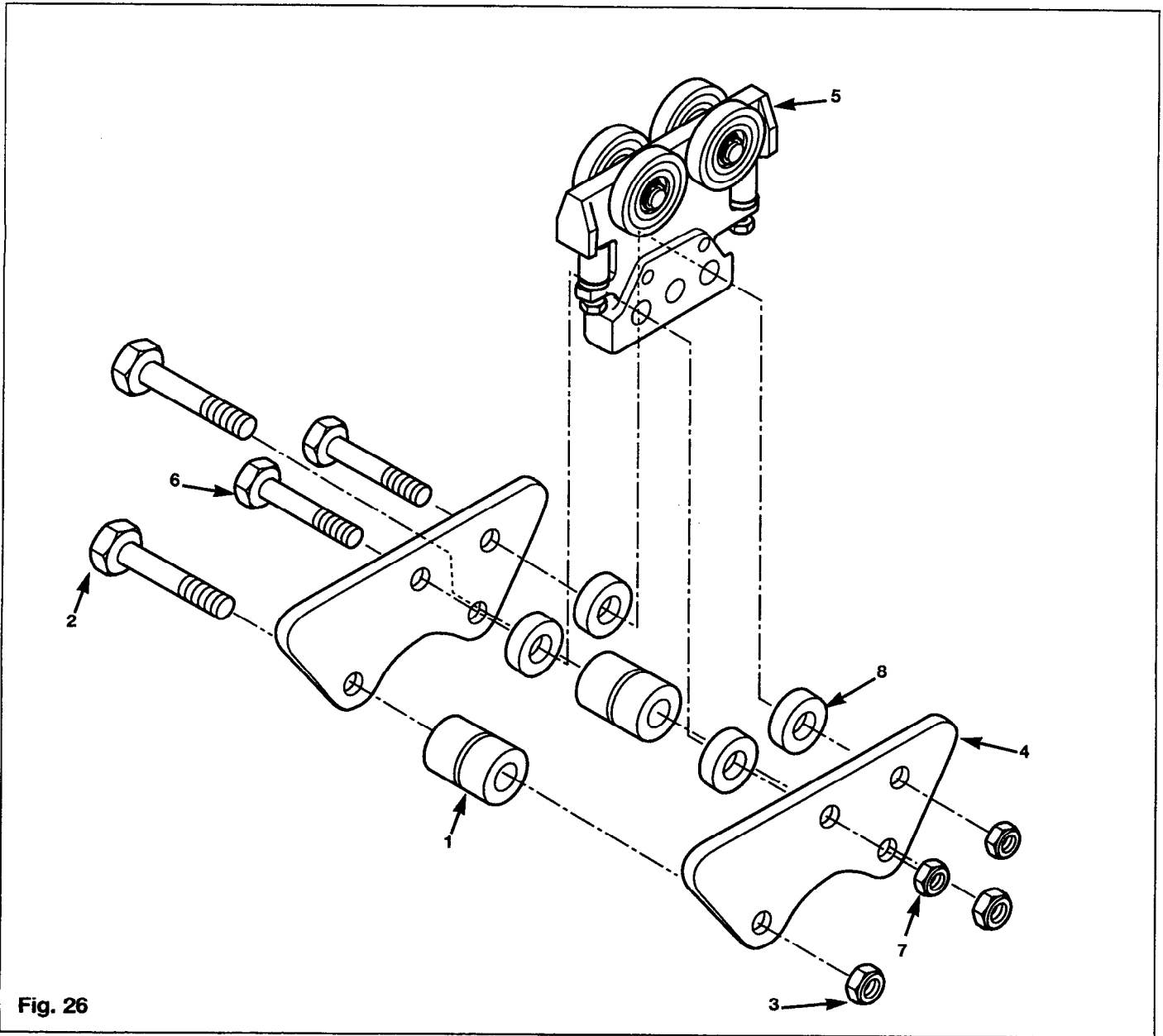

Fig. 26

KITS					
Item	16305 ZRA1 6.5 in. Unit	16355 ZRAT 6.5 in. Unit	16344 ETA4 6.5 in. Unit	16307 IRV2 6.5 in. Unit	Quantity
1	17025 - Bushing	17025	17025	17025	2
2	17047 - Screw	17047	17047	17047	2
3	17060 - Nut	17060	17060	17060	2
4	17125 - Trolley Bracket	17125	17125	17125	2
5	30279 - Trolley	31056 - Trolley	30743 - Trolley	31525 - Trolley	1
6	72005 - Screw	72005	72005	72005	2
7	75563-Nut	75563	75563	75563	2
8	30073-500 - Spacer	30073-500	30073-500	30073-500	4

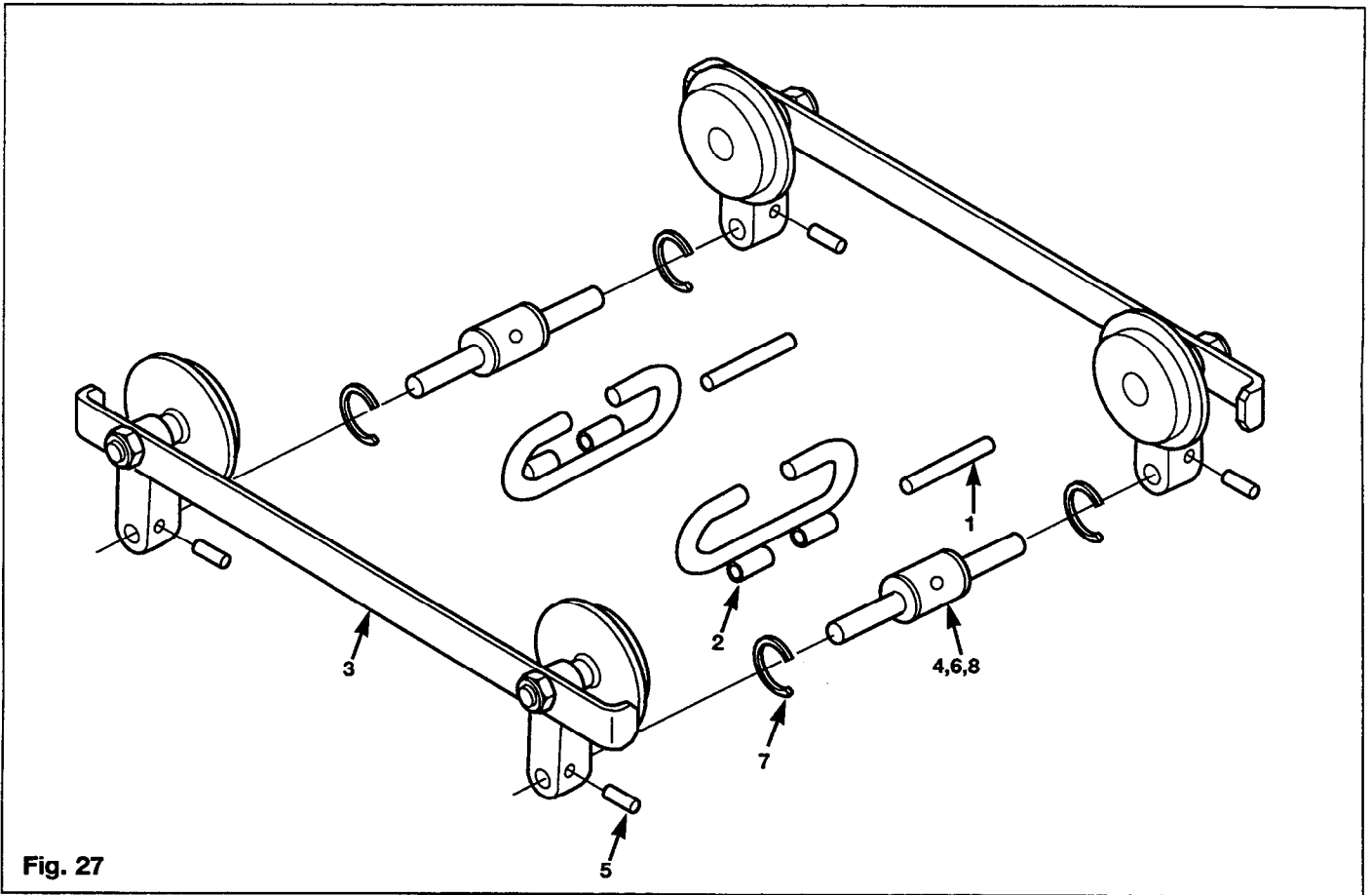

Fig. 27

KITS				
Item	16320 - T-Rail 6.5 in. Unit	Quantity	16420 - T-Rail 10 in. Unit	Quantity
1	01902 - Spring Pin	1	1902	2
2	01925 - Rail Safety	1	1925	2
3	16006 - Trolley Half	2	16013 - Trolley Half	2
4	16043 - Axle	2	16043	2
5	16060 - Spring Pin	4	16060	4
6	17045 - Bushing	2	17045	2
7	17046 - Bushing Clip	4	17046	4
8	70438 - Set Screw	2	70438	2

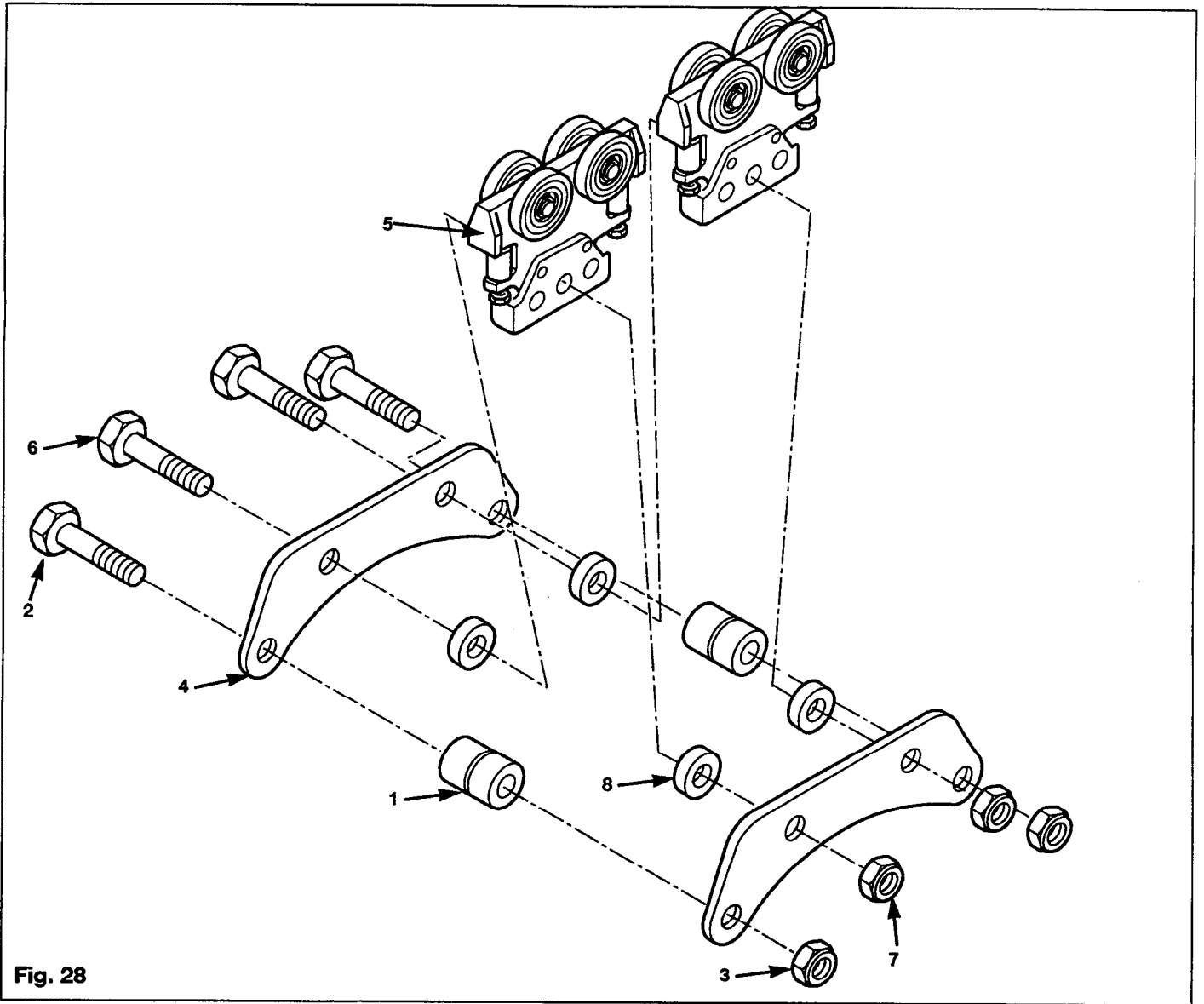

Fig. 28

KITS					
Item	16405 ZRA1 10 in. Unit	16455 ZRAT 10 in. Unit	16444 ETA4 10 in. Unit	16407 IRV2 10 in. Unit	Quantity
1	17025 - Bushing	17025	17025	17025	2
2	17047 - Screw	17047	17047	17047	2
3	17060 - Nut	17060	17060	17060	2
4	17220 - Trolley Bracket	17220	17220	17220	2
5	30279 - Trolley	31056 - Trolley	30743 - Trolley	31525 - Trolley	2
6	72005 - Screw	72005	72005	72005	2
7	75563 - Nut	75563	75563	75563	2
8	30073-500 Spacer	30073-500	30073-500	30073-500	4

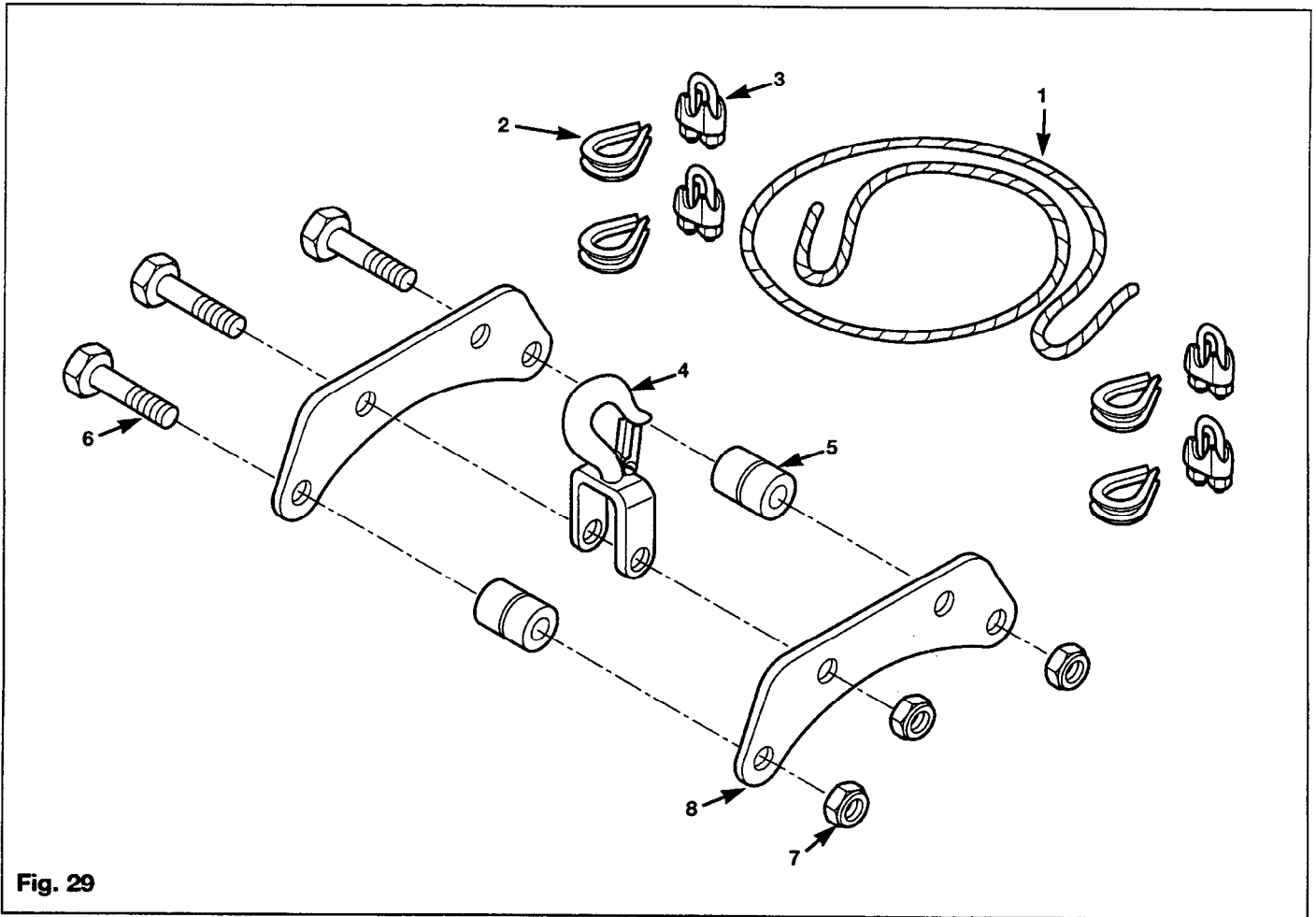

Fig. 29

KITS			
Item	16360 - Hook Mount 6.5 in. Unit	16460 - Hook Mount 10 in. Unit	Quantity
1	10096 - Safety Cable	10096	3 ft.
2	10210 - Thimble	10210	2
3	10230 - Clamp	10230	4
4	17010 - Top Hook	17010	1
5	17025 - Bushing	17025	2
6	17047 - Screw	17047	2
7	17060 - Nut	17060	2
8	17505 - Bracket Top Hook	17012 - Bracket Top Hook	2

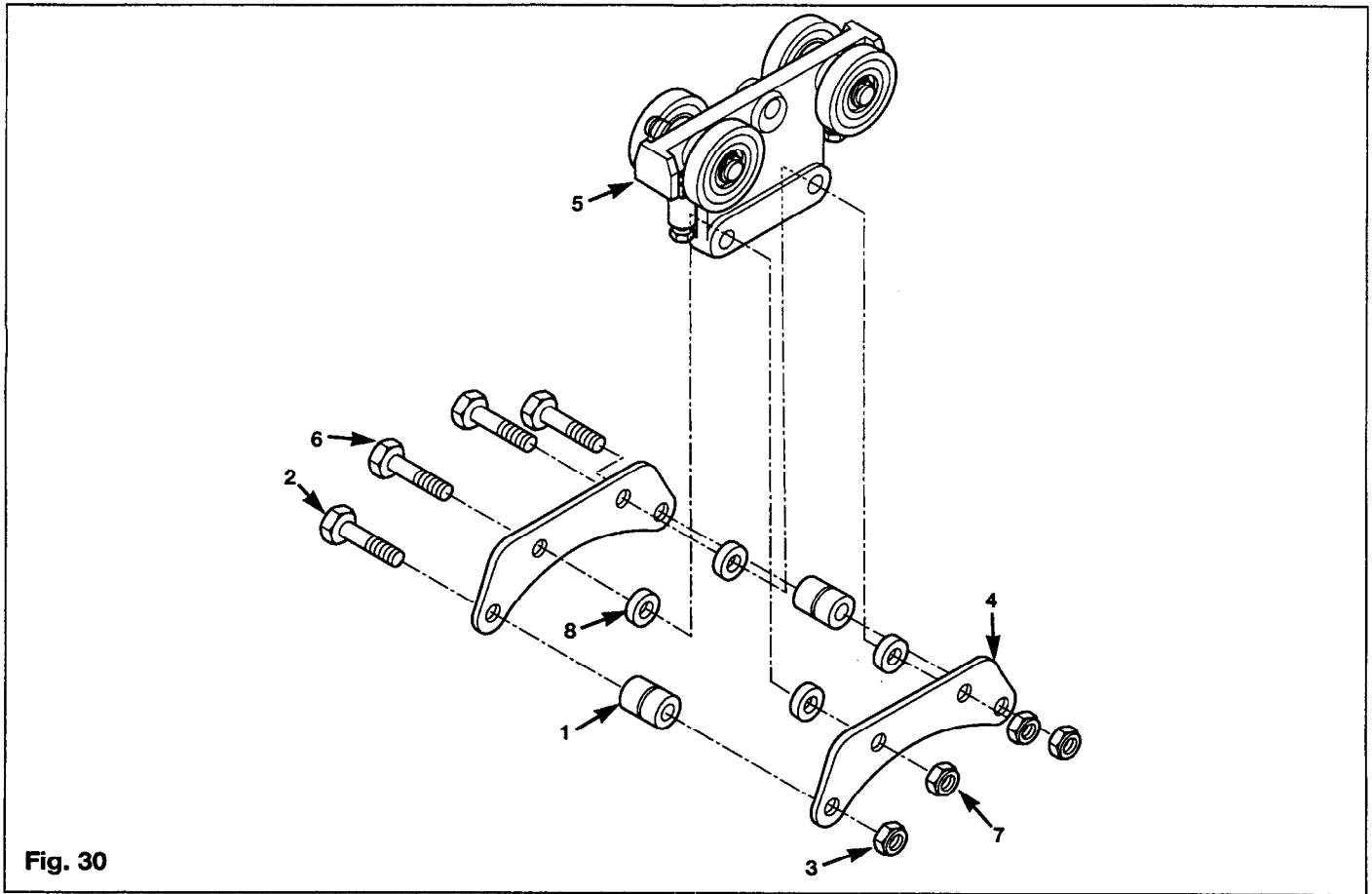

Fig. 30

Item	16300 ZRS2/3 6.5 in. Unit	16310 ZRA2 6.5 in. Unit	16315 KBK II 6.5 in. Unit	16345 ETA-8 6.5 in. Unit	Quantity
1	17025 - Bushing	17025	17025	17025	2
2	17047 - Screw	17047	17047	17047	2
3	17060 - Nut	17060	17060	17060	2
4	17110 - Trolley Bracket	17110	17110	17110	2
5	30510 - Trolley	30015 - Trolley	30030 - Trolley	30929 - Trolley	1
6	72626 - Screw	72626	72626	72626	2
7	75566 - Nut	75566	75566	75566	2
8	30073-312 - Spacer	30073-312	30073-312	30073-312	4

Item	16400 ZRS2/3 10 in. Unit	16410 ZRA2 10 in. Unit	16415 KBK II 10 in. Unit	16445 ETA-8 10 in. Unit	Quantity
1	17025 - Bushing	17025	17025	17025	2
2	17047 - Screw	17047	17047	17047	2
3	17060 - Nut	17060	17060	17060	2
4	17215- Trolley Bracket	17215	17215	17215	2
5	30510 - Trolley	30015 - Trolley	30030 - Trolley	30929 - Trolley	1
6	72626 - Screw	72626	72626	72626	2
7	75566 - Nut	75566	75566	75566	2
8	30073-312 - Spacer	30073-312	30073-312	30073-312	4

Item	16380 - Opt 6.5 in. Unit	16480 - Opt. Mount 10 in. Unit	Quantity
1	17025 - Bushing	17025	2
2	17047 - Screw	17047	2
3	17060 - Nut	17060	2
4	95488-S - Suspension Bracket	95486-S - Suspension Bracket	2

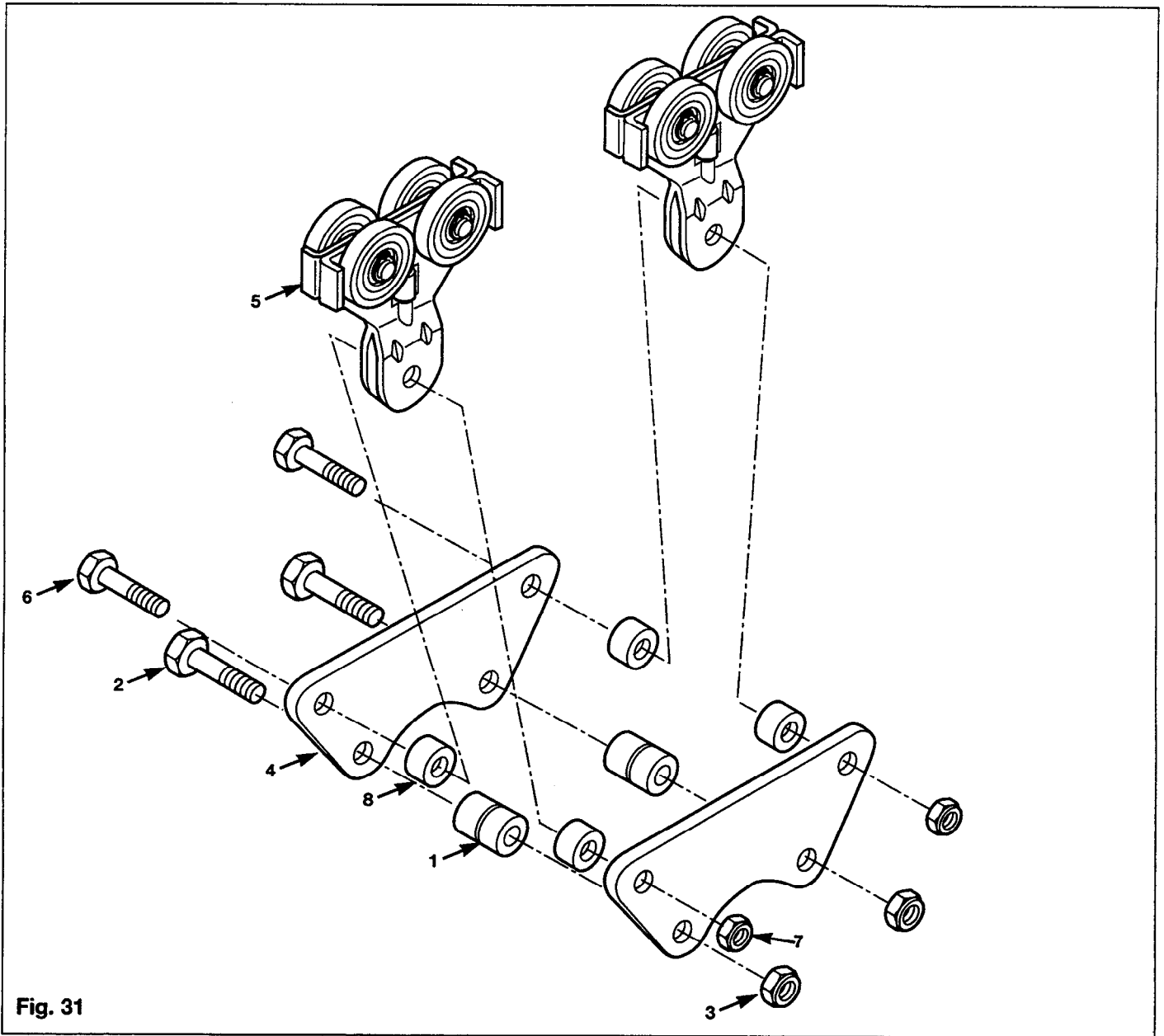
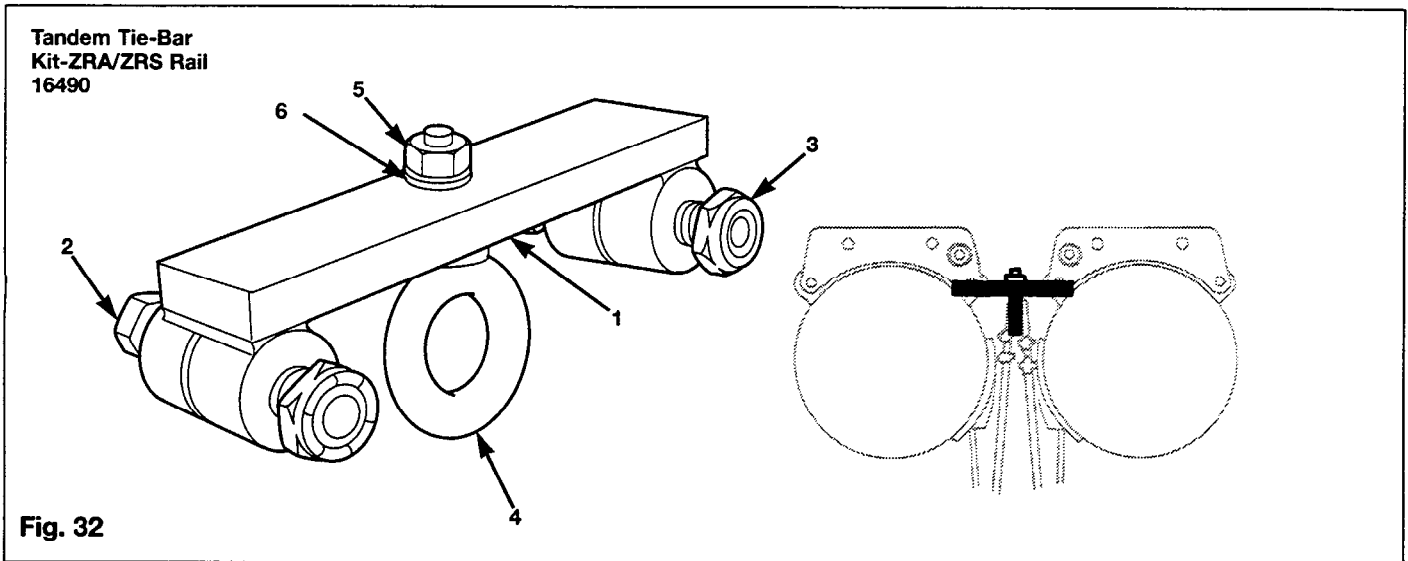

Fig. 31

KITS			
Item	16325 - KBK I 6.5 in. Unit	16425 - KBK I 10 in. Unit	Quantity
1	17025 - Bushing	17025	2
2	17047 - Screw	17047	2
3	17060 - Nut	17060	2
4	17120 - Trolley Bracket	17220 - Trolley Bracket	2
5	30603 - Trolley	30603	2
6	72005 - Screw	72005	2
7	75563 - Nut	75563	2
8	30073-594 - Spacer	30073-594	4

Suspension Kits (Continued)



Item	Part #	Description	Qty.
1	16200	Tandem Tie-Bar	1
2	17047	Cap Screw	2
3	17060	Lock Nut	2
4	16155	Tandem Reeve Eyebolt	1
5	75512	Nut	1
6	74513	Lock Washer	1

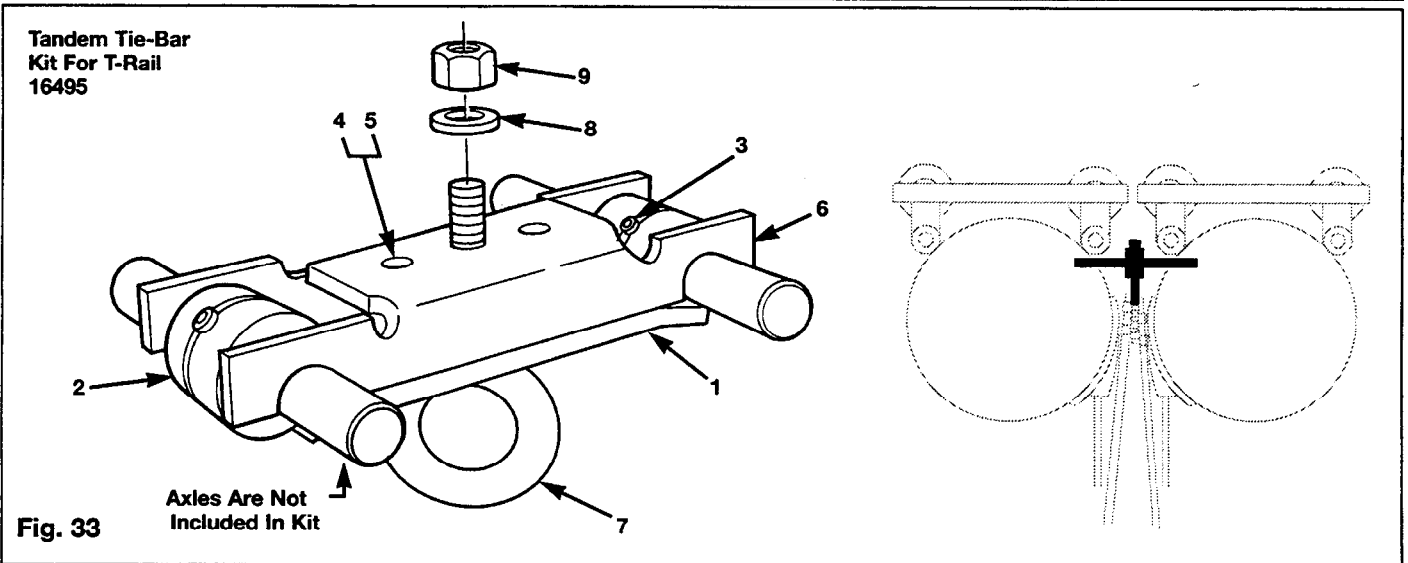

Item	Part #	Description	Qty.
1	16047	Tie-Bar Clip	1
2	16052	Steel Axle Bushing	2
3	16093	Set Screw	2
4	16098	Socket Head Screw	2
5	16099	Lock Washer	2
6	16112	T-Rail Tie-Bar	1
7	16155	Tandem Reeve Eyebolt	1
8	74513	Lock Washer	1
9	75512	Nut	1

Preventive Maintenance Checks and Service



CAUTION

Clean, dry air must be used at all times when operating these units.

Preventive Maintenance

These preventive maintenance recommendations are designed to prevent unexpected breakdowns and problems through periodic inspection and maintenance. Maintenance intervals should be based on frequency of usage and operating environment. Frequent usage, or dirty operating conditions require more frequent servicing. **A clean, dry air supply will help keep the equipment functioning properly.** On page 45 you will find a load positioner inspection and maintenance report. Using this report will aid in tracking component failures or faults. We recommend the use of this report as a preventive maintenance tool.

Wire Rope and Load Hooks

Wire rope, load hooks and clamps should be inspected on a daily basis. Time intervals should be based on the frequency of usage and in accordance with standard wire rope manufacturers specifications. Refer to Preventive Maintenance Schedule.

Load Positioner Lubrication

Basic Units: There are only 3 moving parts (ball nut, thrust bearing and piston) inside the unit that require periodic cleaning and lubrication. Cleaning usually requires complete disassembly of the unit and a thorough washing in a solution, such as mineral spirits.

Notice: The special lubricants mentioned in the reassembly instructions are recommended for the units and are available through Ingersoll-Rand.

Lubrication can be accomplished by partial disassembly of the unit while still on the overhead rail as follows:

1. On series E and S units, turn pilot regulator screw (counter-clockwise) until wire rope is slack. On series P units, depress the down lever until wire rope is slack.
2. Remove load from unit.

3. Turn off air supply.
4. Remove wire rope guide, end cap and piston. Refer to Unit Rebuild Disassembly steps 5, 6, and 7.
5. Using a paint brush (or a similar object) reach through the wire rope window in the housing and apply approximately a tablespoon of lubricant (10886) to ball screw.

Notice: Lubricant (10885) must be used in 500 lb. Unit.

6. Using a clean rag, wipe off piston, cylinder bore of housing and ball screw cap.
7. Apply lubricant (10885) to cylinder bore and O.D. of ball screw cap. To reassemble refer to Unit Rebuild Assembly steps 5-14.
8. Attach control package to end cap. Turn on air.
9. Readjust unit, per Control Operational Adjustments.

Air Supply

Be sure that the air supply is free of rust, dirt, water and oil. Use of a good air filter and in line regulator is highly recommended. 100 psi is required to operate the unit at its maximum capacity. Lower pressure reduces unit capacity accordingly. **Do not use an air in-line oiler. Oil will damage the unit and controls.**

Chain Lubrication

Lubrication of chain should be performed when it is noted that chain is dry. Use part number 10885 to lubricate.

Units Not in Regular Use

1. Units which have been idle for a period of one month or more, but less than one year, should be given an inspection conforming with the requirements of "Frequent Inspection" prior to being placed into service.
2. Units which have been idle for a period of more than one year should be given an inspection conforming with the requirements of "Periodic Inspection" prior to being placed into service.
3. Standby units should be inspected at least semi-annually in accordance with the requirements of "Frequent Inspection." In abnormal operating conditions units should be inspected at shorter intervals.

Preventive Maintenance Schedule

Component	Inspection	Criteria for Operation	Daily <small>(1st Operation of Shift)</small>	Frequent <small>(Less than 6 months/semi annual)</small>	Periodic <small>(More than 6 months/annual)</small>
Chain	Lubrication	Wet to the touch along entire length of chain	X	X	X
	Wear: Reference ANSI Standard for Welded Link Chain Maintenance Sec. 16-2.5 – Page 44	Links not worn into each other at contact points Ref. Fig. 42	X	X	X
Wire Rope	Kinks	No visible kinks on entire length	X	X	X
	Fraying	No visible fraying on entire length	X	X	X
	Bird caging	No visible separations on entire length	X	X	X
Clamps	Tightness	Clamp will not slide on wire rope, or loose	X	X Torque check clamps at 7.5 ft. lbs	X Torque check clamps at 7.5 ft. lbs
	Cracks	No visible cracks	X	X	X
Load Hook	Cracks	No visible cracks	X		X
	Swivel	Smooth operation and free rotation			
	Safety Latch	Positive locking of latch	X		X
Reeve Block	Cracks	No visible cracks	X		X
	Swivel	Smooth operation and free rotation			
	Safety Latch	Positive locking of latch	X		X
	Hardware	Center pulley bolt for full engagement	X	X	X
	Pulley	Smooth operation when in motion	X		X
Suspension Kit	Hardware	No loose or missing hardware	X	X	X
	Trolley Body	Aluminum–no visible cracks. Steel–no visible broken welds	X		X
	Trolley Wheels	Smooth operation with no binding	X		X
	Hook Mount (Optional)	Positive locking of latch	X		X
	Safety Cable (Optional)	No loose clamps	X	X Torque check clamps at 7.5 ft. lbs	X Torque check clamps at 7.5 ft. lbs
Load Positioner	Smooth operation	No binding or resistance in motion	X	X	X
	Lubrication	Piston and ball screw for grease			X
	Wear	Internal parts for excessive wear Ref. Unit Cleaning and Inspection			X

Component	Inspection	Criteria for Operation	Daily (1st Operation of Shift)	Frequent (Less than 6 months/semi annual)	Periodic (More than 6 months/annual)
Controls	Fittings	No visible cracks, leaks or looseness	X		X
	Tubing	No visible bulges, cracks, kinks	X		X
	Handles	No visible cracks, leaks, looseness, or sticking of buttons	X		X
	Manifold/Regulator	No visible cracks, leaks or looseness of hardware	X		X

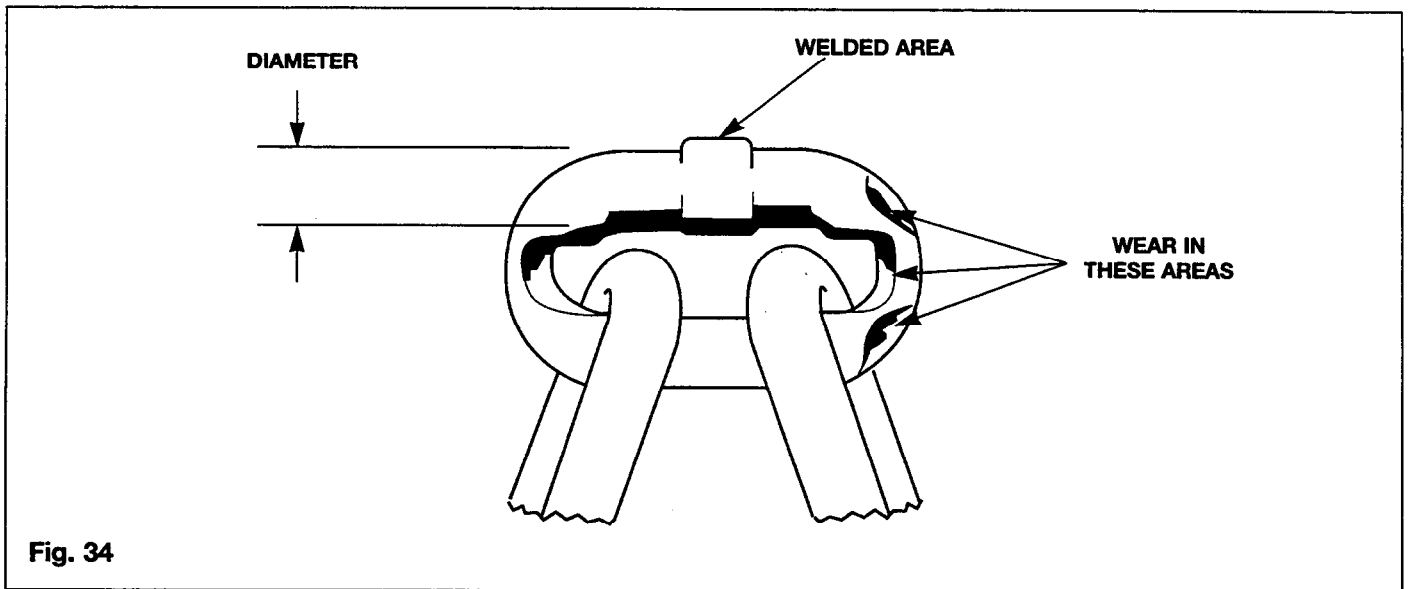
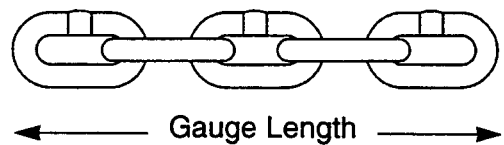

Fig. 34

LOAD CHAIN: Measure the chain for stretching by measuring across five link sections all along the chain paying particular attention to the most frequently reeved links. When any five links in the working length reaches or exceeds the discard length, replace the entire chain (Refer to Fig. 34 and table). Always use genuine **Ingersoll-Rand** Material Handling replacement load chain.

Table

Chain Size	Length When New		Discard Length	
	in	mm	in	mm
3/16 in. (5 mm) Diameter	3.147	79	3.24	82



(Dwg. MHTPA0041)

Reprint from ASME/ANSI B30.16-1987

Section 16-2.5 – Welded Link Chain Inspection, Replacement, and Maintenance

16-2.5.1 Welded Link Chain Inspection

(a) Test the hoist under load in lifting and lowering directions and observe the operation of the chain and sprockets. The chain should feed smoothly into and away from the sprockets.

(b) If the chain binds, jumps, or is noisy, first see that it is clean and properly lubricated. If the trouble persists, inspect the chain and mating parts for wear, distortion, or other damage.

(c) Examine visually for gouges, nicks, weld spatter, corrosion, and distorted links. Slacken the chain and move the adjacent links to one side to inspect for wear at the contact points. If wear is observed or if stretching is suspected, the chain should be measured according to the hoist manufacturer's instructions. If instructions are not available, proceed as follows:

(1) select an unworn, unstretched length of the chain (e.g., at the slack end);

(2) suspend the chain vertically under tension and, using a caliper-type gauge, measure the outside length of any convenient number of links approximately 12 in. to 24 in. (305 mm to 610 mm) overall;

(3) measure the same number of links in the used sections and calculate the percentage increase in length.

16-2.5.2 Welded Link Chain Replacement

(a) If the used chain exceeds the hoist manufacturer's recommended length (or in the absence of such recommendation, if the used chain for hand chain operated hoists is 2-1/2% longer than the unused chain, or the used chain for powered hoists is 1-1/2% longer than the unused chain), replace the chain. Repairing of load chain by welding or any other means shall not be attempted by anyone other than the chain manufacturer.

(b) The existence of gouges, nicks, corrosion, weld spatter, or distorted links is sufficient reason to question chain safety and consider chain replacement. Safety in this respect depends largely upon the use of good judgment by a designated person in evaluating the degree of deficiency.

(c) Replacement chain shall be the same size, grade, and construction as the original chain furnished by the hoist manufacturer, unless otherwise recommended by the hoist manufacturer due to actual working conditions.

(d) Load chain links which pass over the hoist load sprocket on edge (alternate to those which lie flat in the pockets) shall be installed (if recommended by the hoist manufacturer) with the welds away from the center of the sprocket. This precaution is not required on idler sprockets which change the direction but not the tension in the chain.

(e) The chain shall be installed without any twist between the hoist and an anchored end on either the loaded side or slack side.

(f) When chain is replaced, disassemble and inspect the mating parts (sprockets, guides, stripper) for wear and replace if necessary.

(g) Discarded load chain shall not be used for slings.

16-2.5.3 Welded Link Chain Maintenance

(a) Load chain and hand chain should be kept clean and free from any coating or deposit that will build up and change their dimensions or reduce flexibility. The cleaning process shall not damage these chains, and any solution used in the cleaning process shall be acid-free.

(b) Load chain articulates slowly under high bearing pressures and should be lubricated as specified by the hoist manufacturer. Hand chain is lightly loaded and normally needs no lubrication.

**INSPECTION AND MAINTENANCE REPORT
Ingersoll-Rand Load Positioner**

Model Number:			Date:		
Serial Number:			Inspected by:		
Reason for Inspection: (Check Applicable Box)					
	1. Scheduled Periodic Inspection (___ Monthly ___ Yearly)	Operating Environment: Normal ___ Heavy ___ Severe ___			
	2. Discrepancy(s) noted during Frequent Inspection				
	3. Discrepancy(s) noted during maintenance				
	4. Other: _____				
Refer to the Parts, Operation and Maintenance Manual "INSPECTION" section for general inspection criteria. Also, refer to appropriate National Standards and Codes of practice. If in doubt about an existing condition contact the nearest Ingersoll-Rand Distributor or the factory for technical assistance.					
COMPONENT	CONDITION		CORRECTIVE		NOTES
	Pass	Fail	Repair	Replace	
Fasteners					
Shafts					
Bearings			---		
Spool					
Wire Rope or Chain Guide(s)			---		
Covers					
Controls					
Hooks			---		
Top	Gate acts as gauge when visually inspecting for stretched, twisted or bent hooks.				
	Damage			---	
	Hook Crack Test Method Used: ___ Dye Penetrant ___ Magnetic Particle ___ Other: _____				
Bottom	Gate acts as gauge when visually inspecting for stretched, twisted or bent hooks.				
	Damage			---	
	Hook Crack Test Method Used: ___ Dye Penetrant ___ Magnetic Particle ___ Other: _____				
Hook Gate			---		
Load Chain			---		
Working length(s) maximum stretch: _____ inches / _____ mm					
Chain Anchors					
Wire Rope					
Working length(s) maximum stretch: _____ inches / _____ mm					
Supporting Structure					
Rail System					Refer to Rail System Manual
Labels and Tags			---		
Other Components (list in NOTES section)					

Unit Rebuild

Disassembly for 6.5 and 10 Inch Units - All Series



CAUTION

Use of replacement parts other than genuine Ingersoll-Rand original parts could result in damage to the Unit and void the Warranty.



WARNING

Turn off air supply to unit and be sure chain or wire rope is slack before attempting any disassembly operations. Refer to Figures 68-71 for your specific unit.

Notice: The unit shown in the following instructions has 120" travel with all controls removed.

1. Place the unit on a bench or suitable clean work area.
2. Remove load hook and wire rope guide.
3. Cut load wire rope above ball stop (if used) (Figure 35).
4. Loosen center bolt in end cap and end cover. Do not remove.

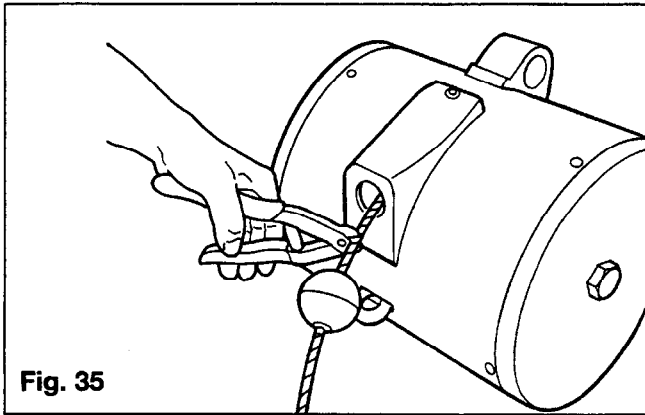

Fig. 35

5. Remove screws (if applicable) around O.D. of end cap. Remove hex head bolt in center of end cap.
6. To remove end cap pull on the wire rope. This will force the piston against the end cap and push the end cap and piston out of the housing.

Notice: DO NOT run reel off end of ball screw or ball bearings will drop out.

Notice: Most units are equipped with thin metal shims inside the ball screw cap to assure an air tight fit of seal (10061). Do not lose shims.

7. Remove the ball screw cap by slipping it off the ball screw (Figure 36).

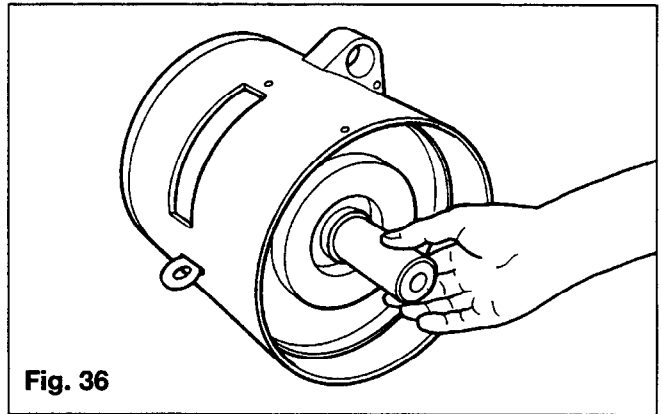

Fig. 36

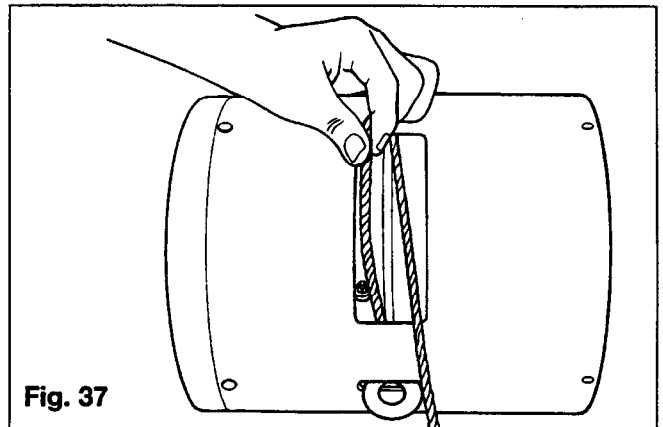

Fig. 37

Notice: The wire rope or chain anchor hole in the reel should be visible at this time. If not, rotate the reel slightly, winding up the wire rope, until the hole is visible. The swaged fitting on the end of the wire rope has a shank which fits into the anchor hole. The fit should not be tight. If the fit is tight, be careful not to damage the reel assembly when removing wire rope (Figures 36 and 37).

8. Push the wire rope into the unit until the swaged fitting is exposed. Pull on the swaged fitting to remove wire rope (Figure 38). On units with chain remove anchor bolt and chain.

Rebuild Unit (Continued)

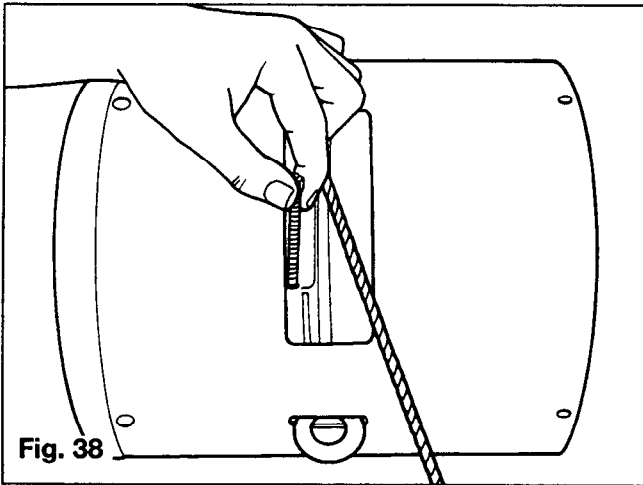

Fig. 38

9. Remove all screws around O.D. of end cover.
10. Remove end cover and ball screw-reel assembly by pushing on the piston end of the ball screw (Figure 39).

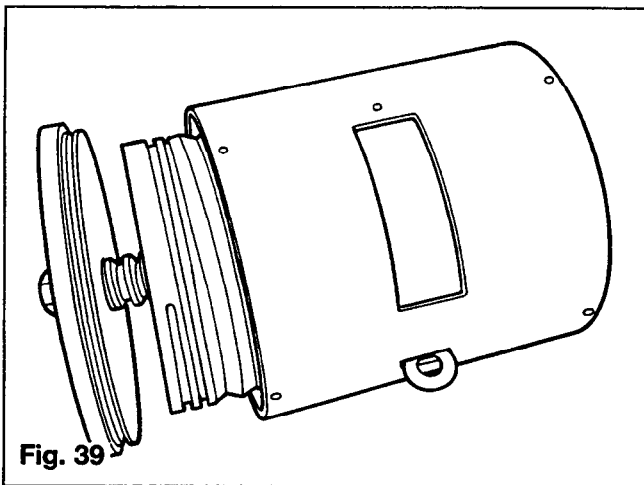

Fig. 39

11. Remove the end cover and brake from the ball screw and reel assembly, by removing the center bolt from end cover.

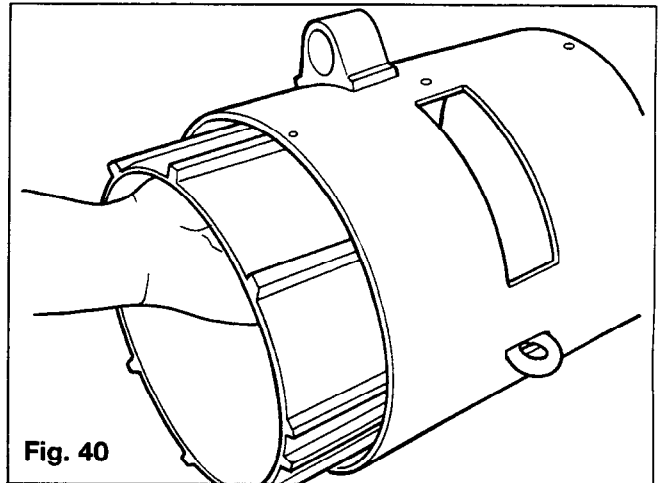

Fig. 40

12. If your unit has a housing liner, remove it at this time (Figure 40).

Disassembly of Ball Screw



CAUTION

Use of replacement parts other than genuine Ingersoll-Rand original parts could result in damage to the Unit and void the Warranty.

Notice: If the ball screw or ball nut do not show signs of excessive wear, disassembly of the ball screw is not required.

1. Place ball screw and reel assembly on a shop towel, with thrust bearing facing upwards.

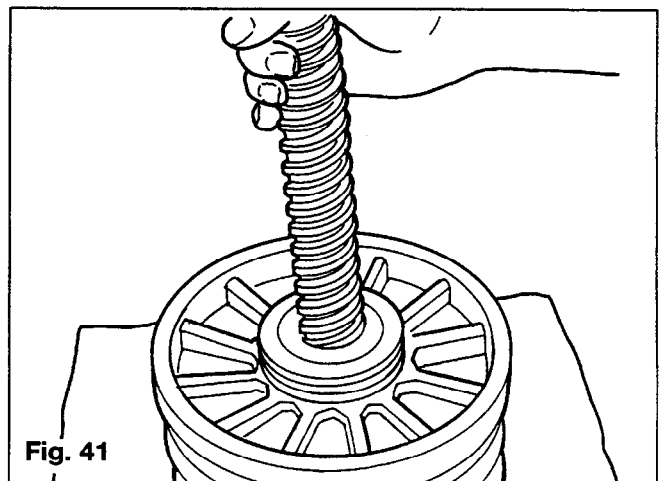
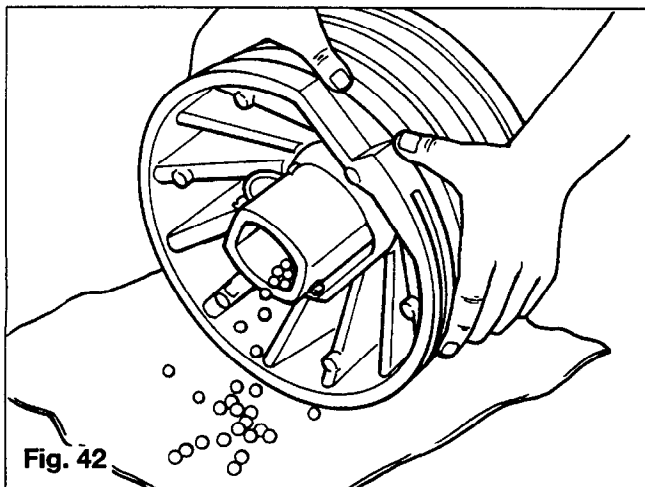

Fig. 41

2. Rotate ball screw counter-clockwise, removing it from the reel assembly (Figure 49).

Rebuild Unit (Continued)



3. Grasp the reel with both hands and gently lift up. The ball bearings will fall on the shop towel. There are 64 ball bearings for models 150, 200 and 350. There are 84 ball bearings for model 500. Lightly tap the reel to remove any remaining ball bearings. If all the balls do not fall out, it may be necessary to insert a wire through the ball return tubes to push out any balls which may be lodged inside. Refer to Figure 42.

Cleaning and Inspection

Now that the basic unit is completely disassembled, the components should be thoroughly cleaned and inspected.

1. Examine the cylinder bore surface for excessive wear. Some small scuff marks may be removed with fine emery cloth. If wear is too excessive, the housing must be replaced. If the unit has a liner, it should also be inspected for wear or possible cracking.
2. Check piston for cracks and wear of the flexible sealing lips. Check steel backing plate for cracks and wear.
3. Inspect ball screw and thrust bearing for excessive wear, pitting, rusting and security in reel assembly.
4. Check wire rope guide for wear. Excessively worn or grooved wire rope guides should be replaced.
5. Inspect reel assembly for cracks and wear of "V" grooves, and anchor hole for deformation.

Ball Screw and Thrust Bearing Replacement

1. **Removing the Thrust Bearing** - The thrust bearing is attached to the reel with a retainer pressed into the hub of the reel approximately 1/4". To remove, use a bearing puller to engage the under-cut at the bottom of the retainer I.D. Refer to Figure 43.

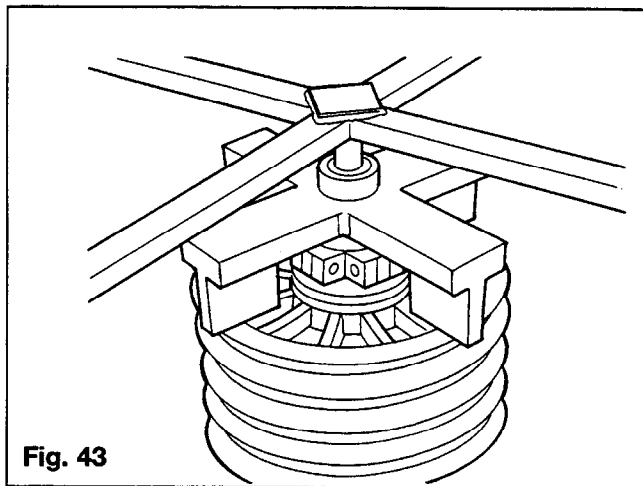

2. **Removing the Ball Screw Nut** - The ball screw nut can be pressed out of the reel using a cylindrical metal slug 2 inches in diameter. Support the reel along the outer portion to allow ball nut to be removed. Press out ball screw nut, being careful not to damage the reel. Refer to Figure 44.

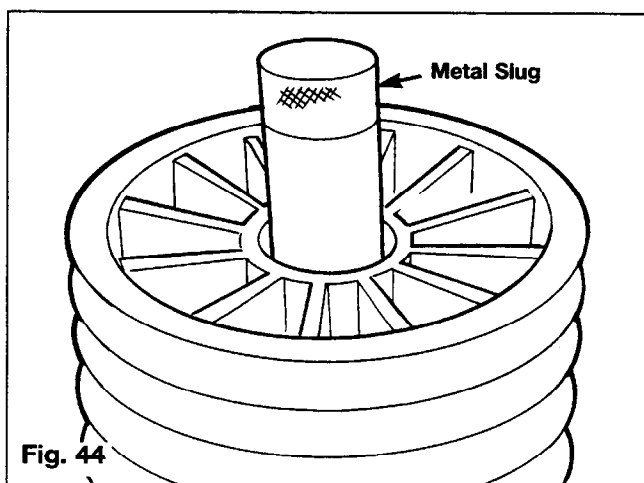

Rebuild Unit (Continued)

3. **Installing New Ball Screw Nut** - To install the ball screw nut, position the washer over the small diameter of the nut. Place pin in position. Align pin with groove in reel and press in the nut. Refer to Figure 45 and 46.

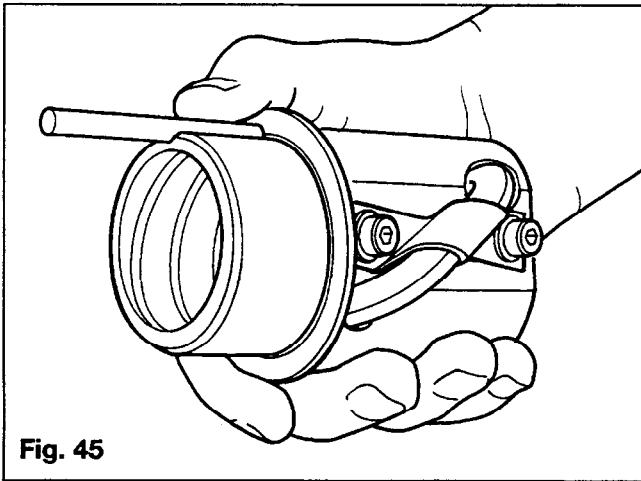

Fig. 45

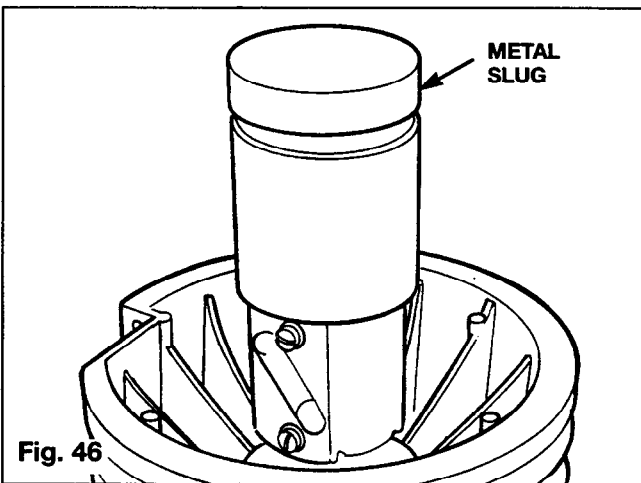

Fig. 46

4. **Installing New Thrust Bearing** - To install the thrust bearing, place the ground I.D. side of the bearing race against the reel, place the retainer through the thrust bearing and press it into the reel. After the retainer is pressed, check the outer bearing race to be sure it rotates freely. The thrust bearing retainer should be .008" to .012" below the surface of the outer bearing race. Refer to Figure 47.

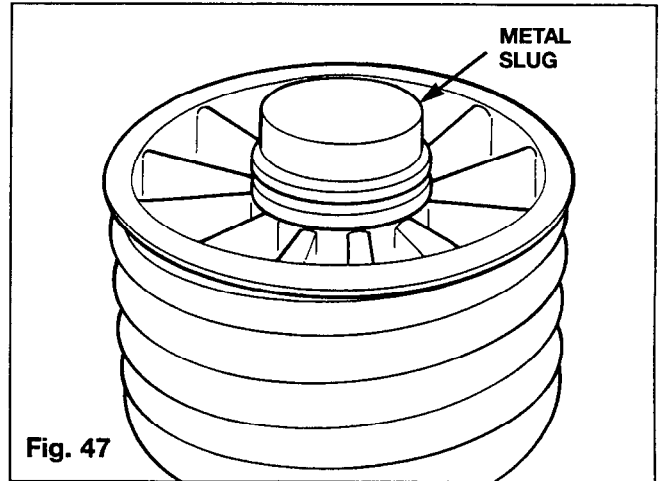

Fig. 47

Ball Screw Reassembly

1. Plug the hole on the slotted end of ball screw with a small piece of paper towel, to prevent the ball bearings from dropping into the threaded hole.
2. Insert the plugged end of the ball screw into ball nut from the thrust bearing side.
3. Turn the ball screw clockwise to thread into the ball nut. Thread the ball screw to within 1-1/2" of the ball nut end.
4. Stand assembly on ball screw and drop in approximately half of the ball bearings. Refer to Figure 48.

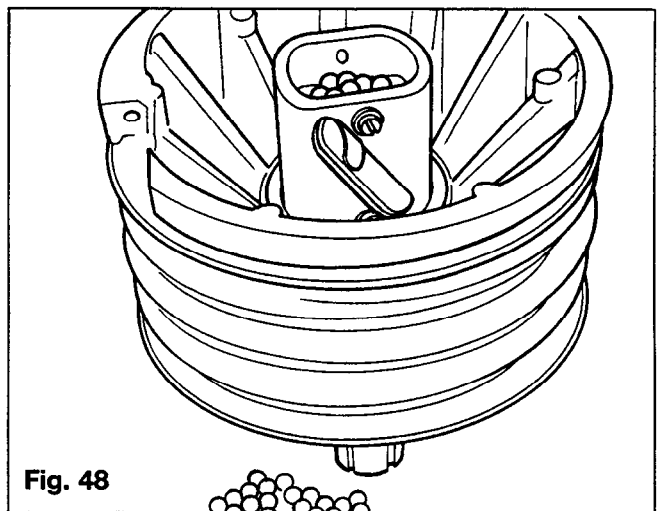
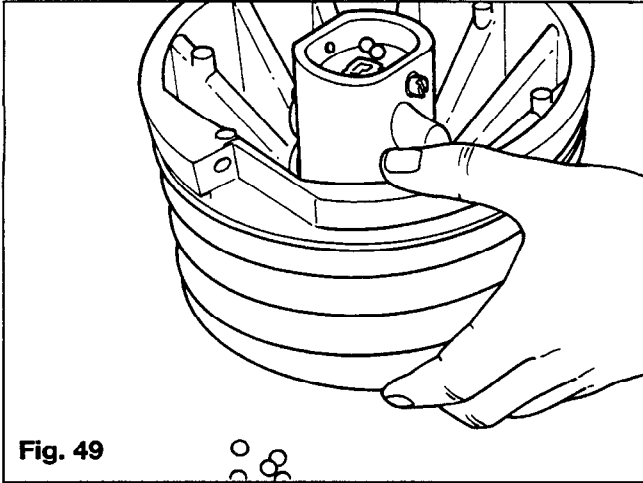

Fig. 48

5. With one hand holding the ball screw, rotate the reel down and up until all ball bearings have rolled into the tubes of the ball nut. Refer to Figure 49-50.

Rebuild Unit (Continued)

6. Lay the reel down on its side with ball screw in a horizontal position. Rotate the ball screw three or four times to seat ball bearings in proper location. Refer to Figure 50.



7. Repeat steps 4, 5 and 6 until all ball bearings are reinstalled into the ball nut.

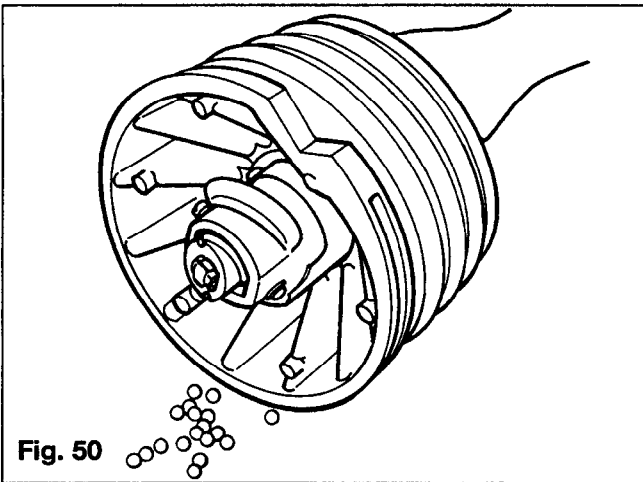

8. Remove paper plug from end of ball screw.

Reassembly

Notice: Before reassembly, make sure all internal parts are clean, properly lubricated and all worn parts have been replaced.

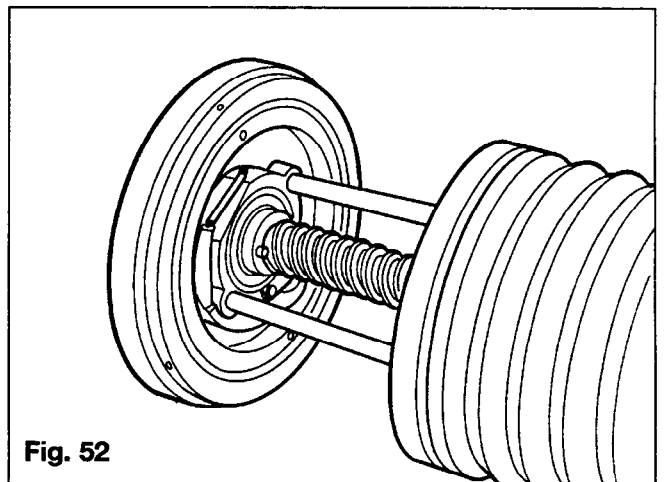
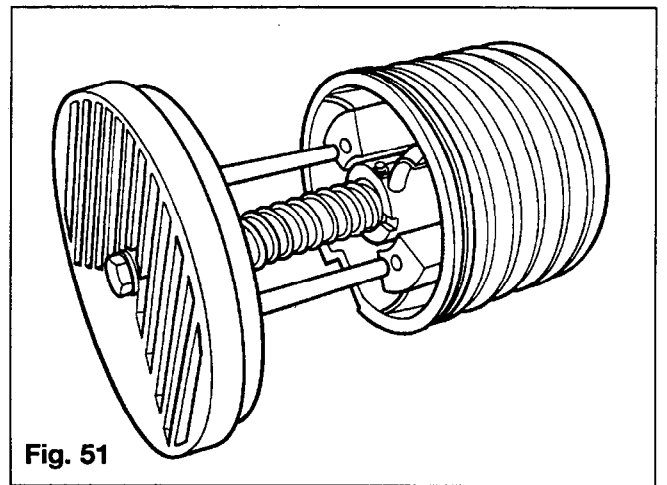

1. Align and insert the brake rods into the holes in the reel (Figure 51). The anti-rotation pins in the end cover must line up with slots in the ball screw (Figure 52) and protrude $1/8"$ to $5/32"$ from the inside surface of the end cover. Insert the shorter bolt through the end cover and thread it into the ball screw. Hand tighten the bolt until the ball screw is held firmly against the end cover. Refer to Figure 52.
2. Lubricate the ball screw and thrust bearing with lubricant (10886).

Rebuild Unit (Continued)

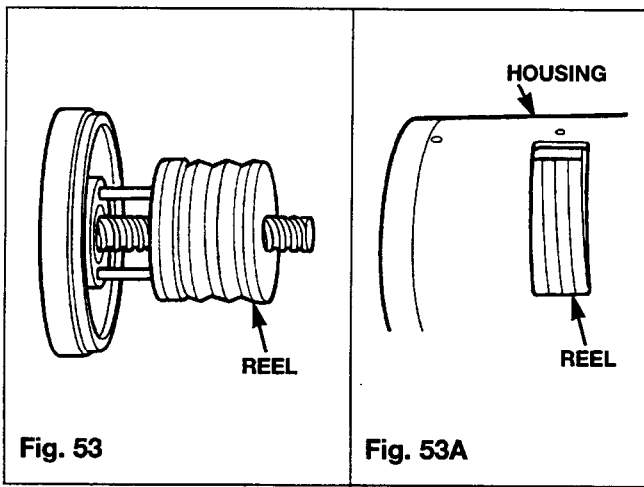

Figures 53 and 53A illustrate the reel and end cover assembly inserted into the housing.

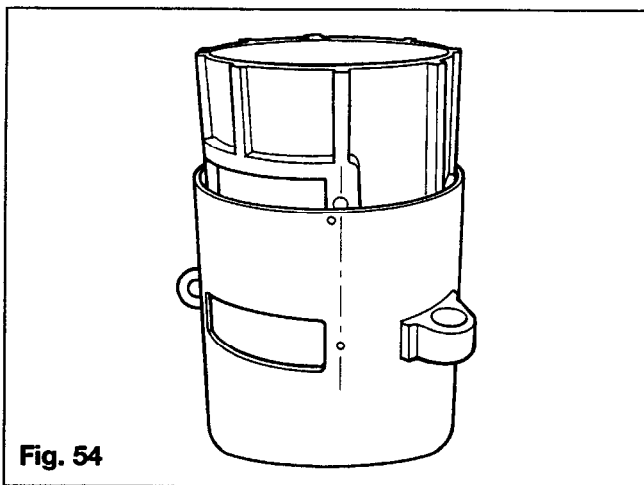

3. Position the housing as shown. Insert liner, if so equipped. Be sure to align the round hole in the liner at top of cut out with wire rope guide bolt hole in housing (Figure 54).

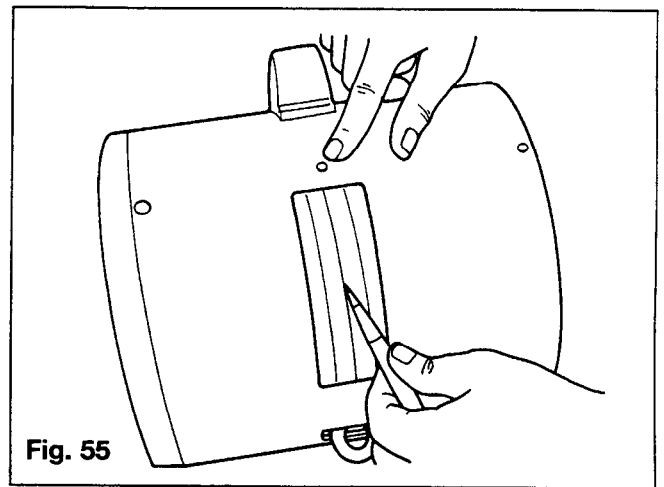

4. Slide the reel and end cover assembly into the housing. Align screw holes in end cover with holes in housing. Check to see that bottom of reel V groove is aligned with tapped hole or stud at top of wire rope guide opening. If it is not in line (Figure 63), rotate the end cover in either direction until the groove is aligned and the bolt holes on the O.D. of the end cover are in line with the bolt holes in the housing. Insert two screws on opposite sides of the housing. Check to see that reel alignment did not change when screws were inserted. If alignment is correct, insert remaining end cover screws.

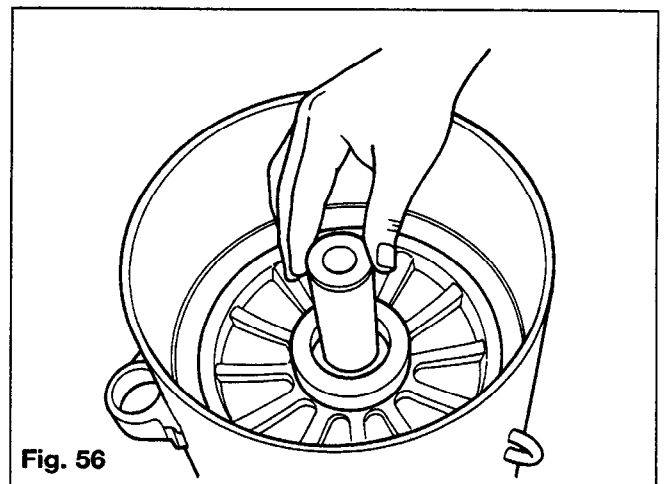

Notice: Most units have metal shims inside the ball screw cap, between the end of the ball screw and the ball screw cap, to obtain air tight fit. If your unit is so equipped, be sure the shims are in place.

5. Stand unit on end. Place ball screw cap over ball screw (Figure 56).

Rebuild Unit (Continued)

6. Apply a very light, even coat of lubricant (10885) to housing cylinder bore and O.D. of the ball screw cap.

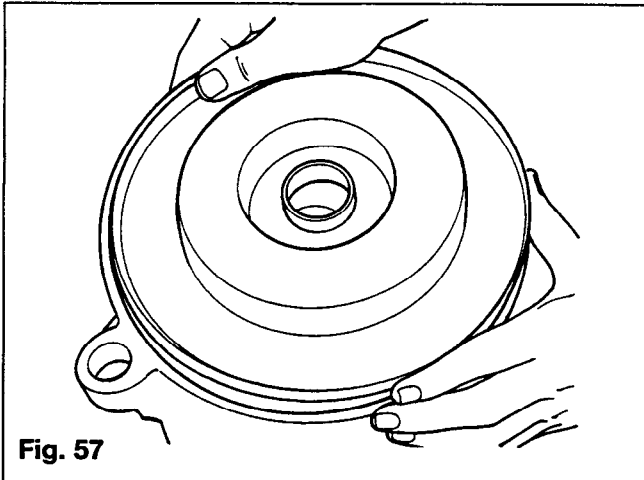

7. Insert the piston into the housing, steel side first and push it down until it contacts thrust bearing (Figure 57).
8. Apply a light coat of Lubricant (10886) to the end cap "O" Ring and insert it in the groove of end cap.

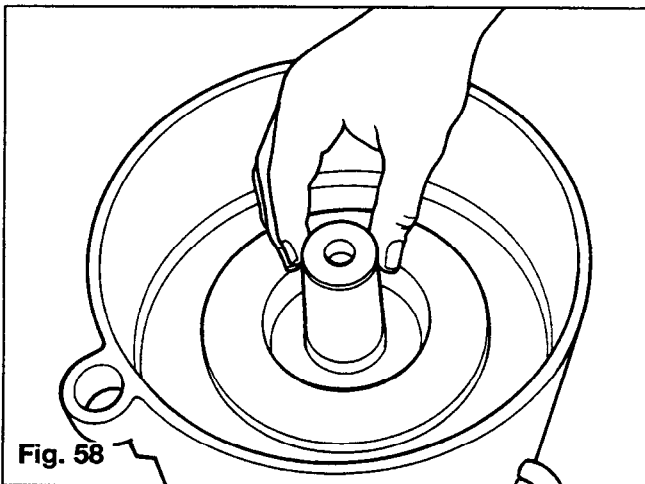

9. Apply a coat of lubricant (10885) to one side of seal (10061). Press lubricated side onto end of the ball screw cap (Figure 58). The lubrication helps hold the seal in place while the end cap is positioned.

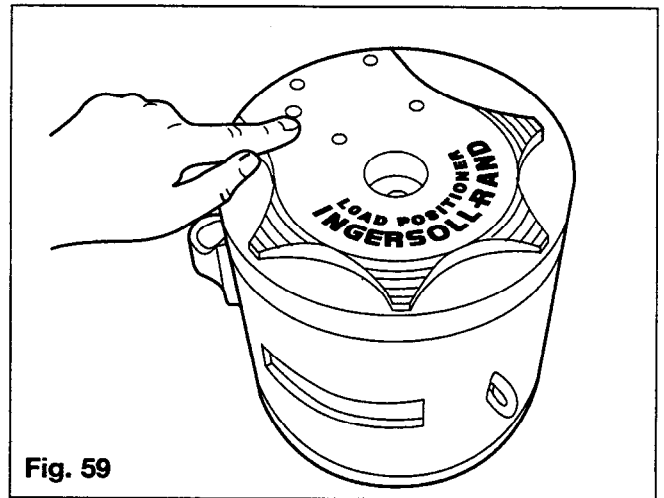

Notice: Be careful not to damage "O" ring during this operation.

10. Install end cap. Tapped holes for screws around the O.D. of end cap must be aligned with corresponding holes in the housing. When the end cap is properly aligned, use a soft hammer to tap it into the housing. Make sure control kit mounting holes are at the top of the unit (Figure 59).
11. Make sure the seal (10061) has not moved during the installation of end cap. The I.D. of the seal should not be visible through the hole in the center of the end cap.
12. Insert bolt into center of the end cap and hand tighten.
13. Insert screws around O.D. of the end cap.
14. Tighten end cap and cover center bolts to 90-100 ft./lbs.

Installing Wire Rope



CAUTION

Use of wire rope other than Ingersoll-Rand wire rope assembly should be avoided. Internal damage to the unit may result.

1. Install new wire rope assembly, by first rotating the reel down (direction of arrow in Figure 60) until the anchor hole in the reel is visible.

Notice: The wire rope must be wrapped by hand twice around the reel for proper operation.

2. The end of the wire rope is inserted down through the anchor hole in the reel and into the groove. Continue pushing wire rope into groove until the end appears at the top of the reel. Grasp this end and pull until swaged fitting on the end of the wire rope is pulled into the anchor hole in the reel (Figure 60).
3. Wrap the wire rope around the reel one more

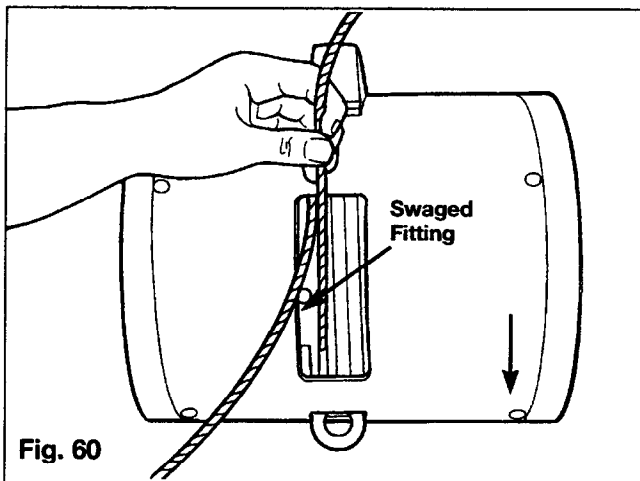

Fig. 60

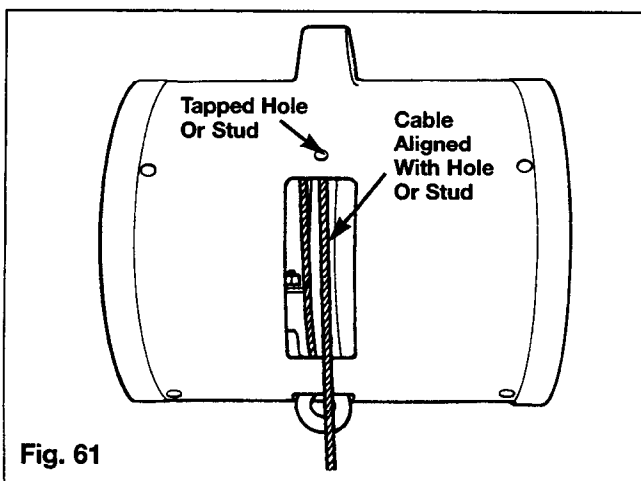

Fig. 61

- time, as described in step 2. The wire rope should be centered in the opening of the housing. Refer to Figure 69.
4. Install the wire rope guide.

Installing Ball Stop

1. To install the ball stop, you must have a control package installed.
2. Turn on air to the unit and slowly wind as much wire rope as possible into the unit.
3. Slide ball stop (10165) and wire rope stop (10200) onto wire rope and up to unit. Swage wire rope stop below ball stop. The correct clearance between the wire rope guide and ball stop is 1/8" to 1/4".

Installing Load Chain

1. Rotate reel (see direction of arrow in Figure 62) until anchor hole is visible.
2. Attach length of wire to last chain link. Locate the first groove in the reel to the right of the anchor hole. Insert wire into reel groove and push wire in direction shown in Figure 62.

Notice: The weld joint of chain length should be facing away from the reel anchor hole.

3. Remove wire and bolt chain end to reel anchor hole.

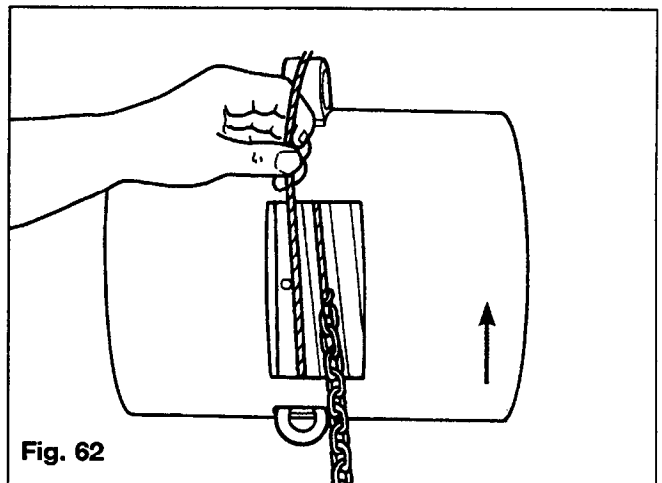

Fig. 62

SAFETY RETRACTION SYSTEM ADJUSTMENTS AND RESETTING



WARNING

Ingersoll-Rand units with capacities of 150 lbs or greater are equipped with the Safety Retraction System, a centrifugal brake that is designed to stop the uncontrolled upward travel of the chain or wire rope in the event of a sudden release or loss of load, and limit the excessive upward acceleration of the empty hook for the safety of the operators. The brake should in no instances be used as a travel limiting stop or up stop. Failure to follow these instructions will result in damage to the brake and the unit. Continuous use of the brake will cause internal damage to the unit and could result in damaging the unit beyond repair.

Notice: *Ingersoll-Rand* installs the spring in hole #2 on the 200 lb., 350 lb., and 500 lb. units and in hole #1 on the 150 lb. unit. To reduce the sensitivity on the 200 lb., 350 lb., and 500 lb. unit place spring in hole #3, 4, or 5. To reduce the sensitivity on the 150 lb. unit place spring in hole #2 or 3.

Notice: *If the brake interferes with the operation of the system in the hole farthest from center, a heavier spring is available through Ingersoll-Rand.*

Safety Retraction System Reset Procedure

P Controls

1. Ensure the vertical path of the load is clear.
2. Press the down lever and release the air in the unit until the load begins to lower.
3. Resume operation.
4. If the brake engages when a load is attached or it interferes with standard operation, the brake must be adjusted. See Safety Retraction System Adjustments for further instructions.

S and E Controls

1. Ensure the vertical path of the load is clear.
2. Grasp the load hook at the lifting eye pad and pull down on the chain or wire rope. Carefully and slowly release the load hook.
3. Attempt to resume operation.
4. If the brake is still engaged.
5. Rotate the pilot regulator screw of the regulator until the load begins to lower. This will change the settings on the control.
6. Follow the appropriate control adjustments to ensure the proper operation of the unit.
7. Resume operation.
8. If the brake engages when a load is attached or it interferes with standard operation the brake must be adjusted. See Safety Retraction System Adjustments for further instructions.

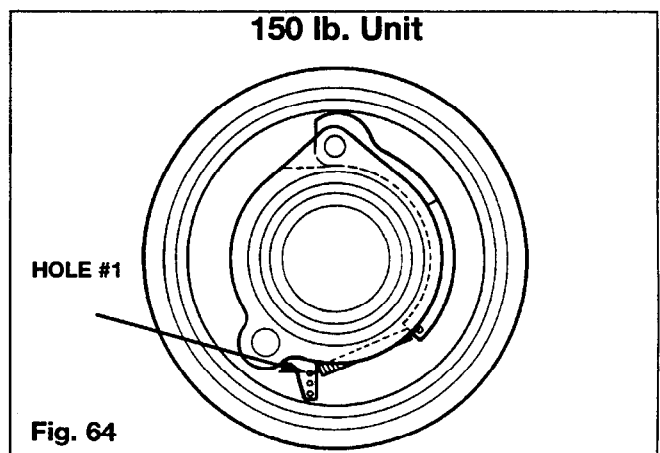
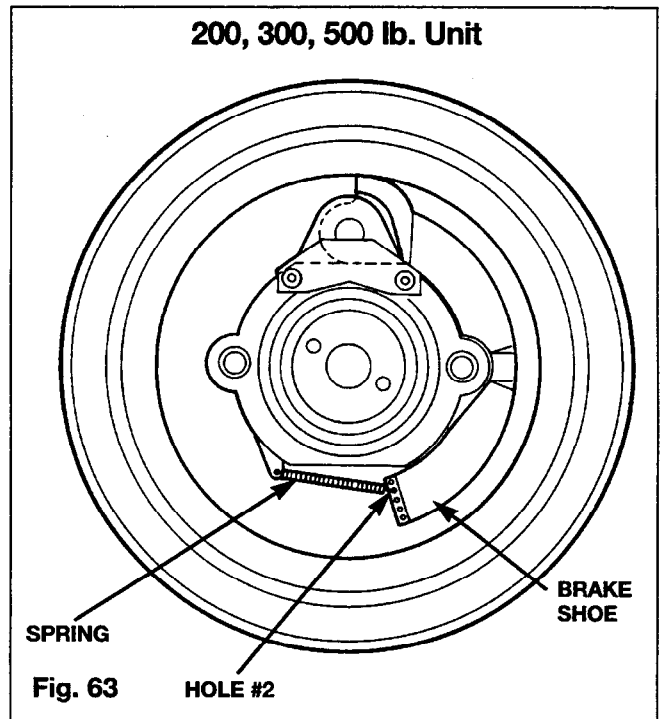

SAFETY RETRACTION SYSTEM ADJUSTMENTS (Continued)



WARNING

Be sure air supply is off and wire rope has slack.

Adjustment Procedure

1. Remove the unit from the overhead suspension.
2. Place the unit on a clean, dry work bench.
3. Remove the control regulator from the unit.
4. Stand the unit on the end cap (control end).
5. Loosen the hex bolt in the center of the end cover.
6. Remove the bolts around the diameter of the housing.
7. Remove the center bolt from the end cover.
8. Remove the end cover assembly.

Notice: Note the position of the bearing retainer between the end cover and the ball screw. Bearing retainer not required for the 200 lb. unit.

9. Place the end cover on the work bench so that the rods are pointing up.
10. With needle nose pliers remove the end of the spring on the brake shoe and place in desired hole. The farther from the center of the unit the spring is set, the less sensitive it will become.

Reassembly

1. Place the unit on its side so the wire rope guide is facing you.
2. With your fingers rotate the reel so it moves toward the end cover. The wire rope or chain will retract.
3. Hold the end cover and align the rods with the holes in the reel. The 150 lb. unit has only 1 rod.

Notice: Be sure the bearing retainer is in place between the ball screw and the brake assembly.

4. Slide the rod(s) and end cover assembly into the hole(s) in the reel until the 9/32" diameter holes in the housing and the anti-rotation notches on the ball screw line up with the pins in the end cover.
5. Install the bolts on end cover O.D.
6. Install the end cover center bolt and torque to 90-100 ft/lb.
7. Install controls and perform operational adjustments as necessary.

Safety Retraction Assembly – 150 lb. Unit

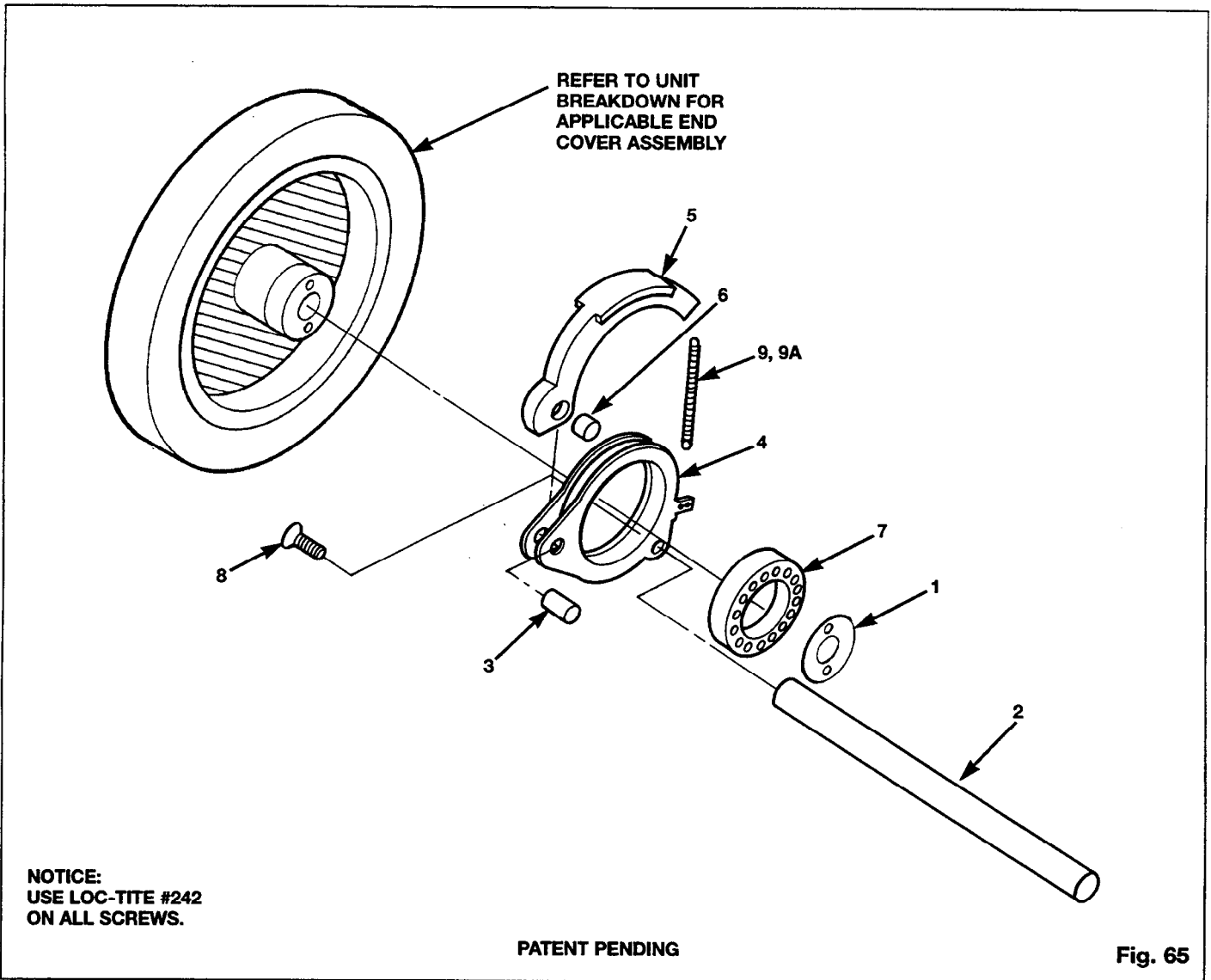

13110 Brake Assembly 150 lb. Unit			
Item	Part #	Description	Qty.
1	13039	Bearing Retainer	1
2	13112	Shaft	1
3	13113	Pivot Shaft	1
4	13114	Brake Rotor	1
5	13116	Brake Shoe	1
6	65054	Bushing	1
7	65074	Radial Bearing	1
8	70427	Screw	1
9	76518	Spring	1
9A	*76517	Heavy Spring	1

* - Heavy Brake Spring Replaces P/N 76518

Safety Retraction Assembly – 200/350/500 lb. Unit

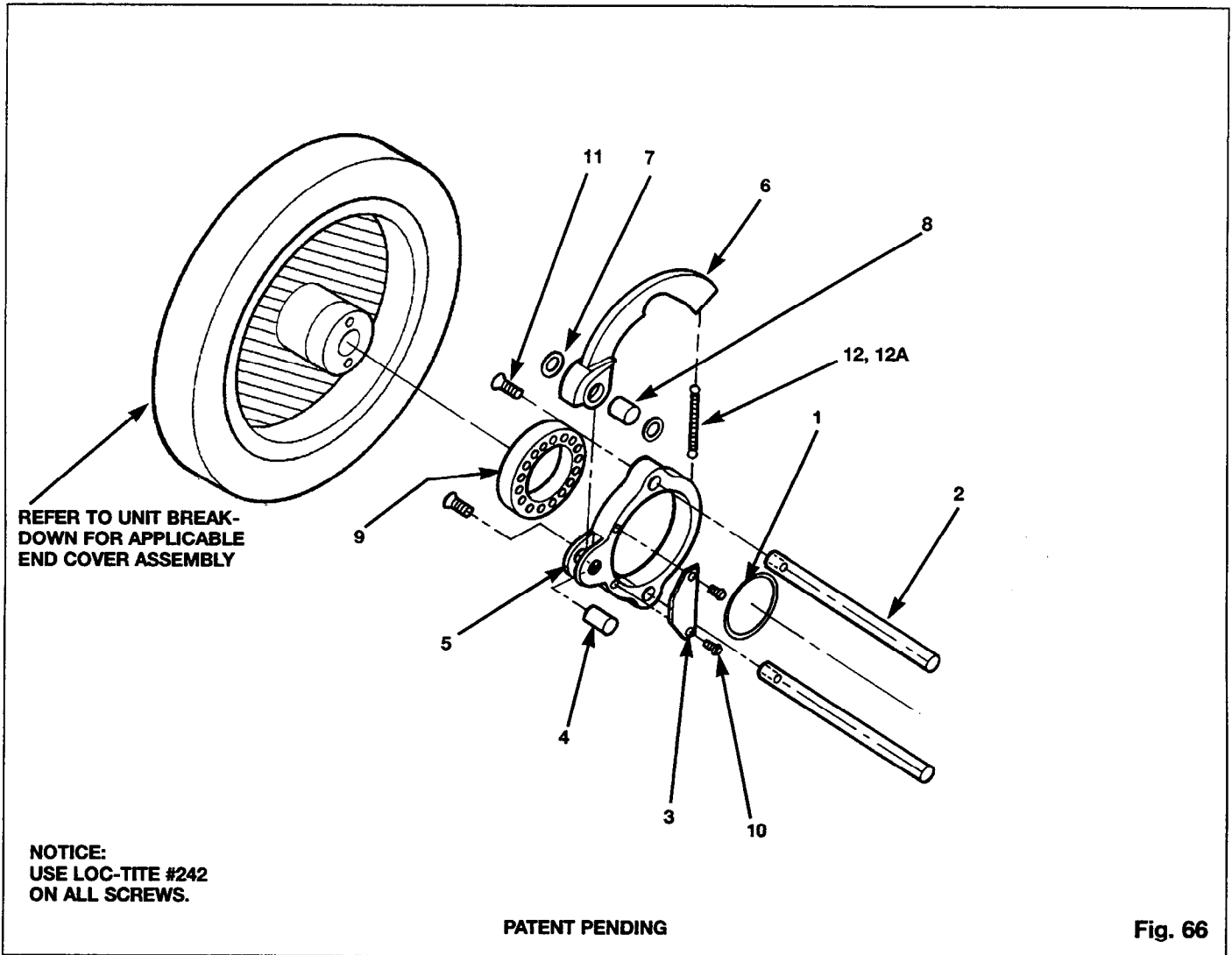

	13120 – Brake Assembly 200 lb. Unit	13135 – Brake Assembly 350 lb. Unit	13140 – Brake Assembly 500 lb. Unit		
Item	P/N	P/N	P/N	Description	Qty.
1	13036	13039	13039	Bearing Retainer	1
2	13112	13112	13142	Shaft	2
3	13122	13122	13122	Shaft Retainer	1
4	13123	13123	13123	Pivot Shaft	1
5	13124	13124	13143	Brake Rotor	1
6	13125	13125	13125	Brake Shoe	1
7	65063	65063	65063	Thrust Washer	2
8	65073	65073	65073	Bushing	1
9	65074	65074	65074	Radial Bearing	1
10	70232	70232	70232	Screw	2
11	70427	70427	70445	Screw	2
12	76517	76517	76517	Spring	1
12A	*76520	*76520	*76520	Heavy Spring	1

* – Replaces 76517 Brake Spring

Down Stop Assembly – 200/325/500 Lb. Unit

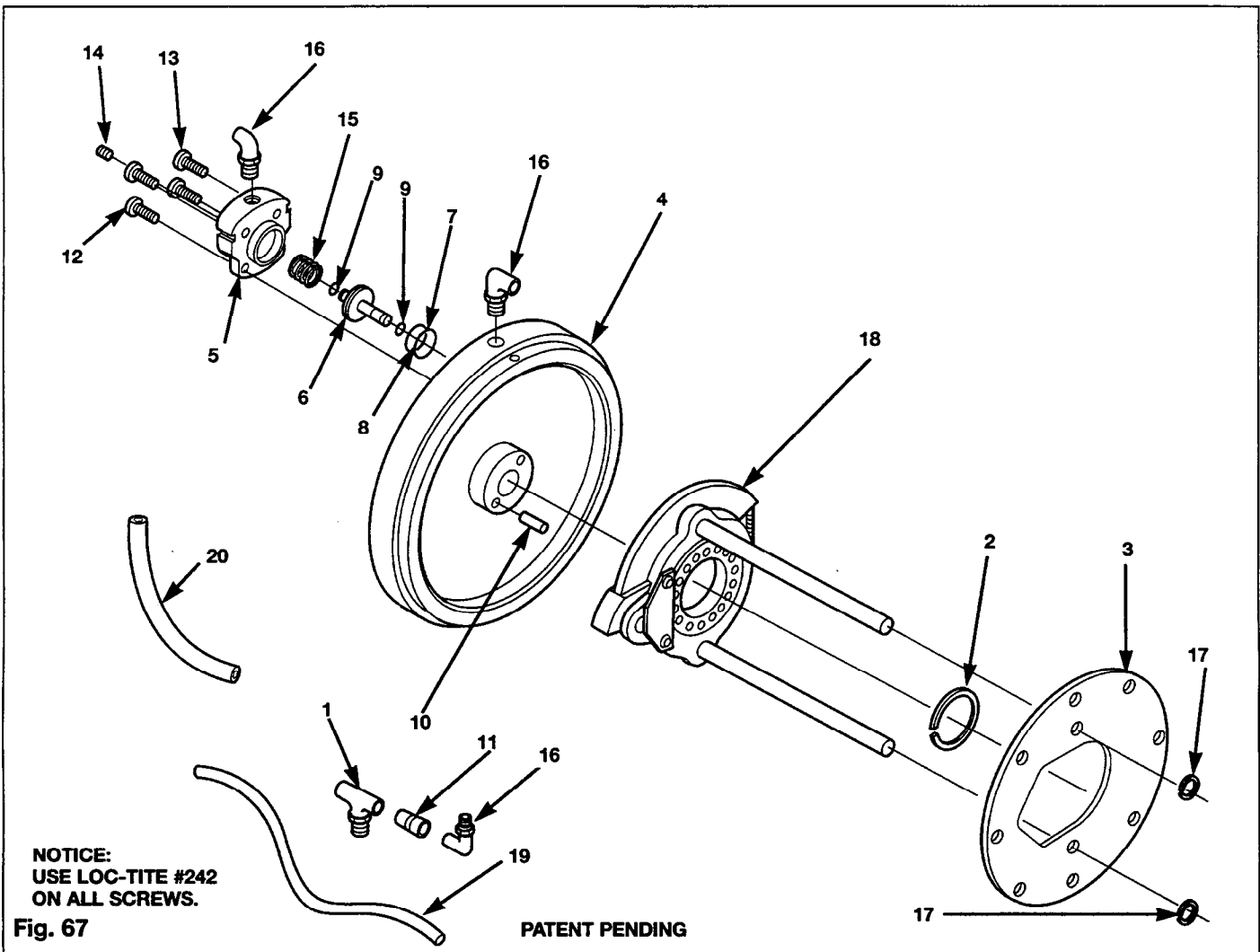

	13301 – Down Stop Assy. 200 lb. Unit	13311 – Down Stop Assy. 325 lb. Unit	13321 – Down Stop Assy. 500 lb. Unit		
Item	P/N	P/N	P/N	Description	Qty.
1	10708	10708	10708	Street Tee	1
2	13036	13039	13039	Retainer Bearing	1
3	13304	13304	13324	Engagement Plate	1
4	13715	13718	13718	End Cover	1
5	13335	13335	13335	Down Stop Cover	1
6	13338	13338	13338	Engagement Pin	1
7	13342	13342	13342	O-Ring	1
8	13343	13343	13343	O-Ring	1
9	13344	13344	13344	Quad Ring	2
10	13440	13440	13440	Anti-Rotation Pin	2
11	13502	13502	13502	Reducer Bushing	1
12	70254	70254	70254	Screw	2
13	70255	70255	70255	Screw	2
14	70256	70256	70256	Screw	1
15	76521	76521	76521	Spring	1
16	93969	93969	93969	Male EL 5/32-1/8 NPT	3
17	99126	99126	99127	Retaining Ring	2
18	**13120	**13135	**13140	Brake Assembly	1
19	93960-Y	93960-Y	93960-Y	Tubing - 5/32 Yellow	2 ft.
20	93960-R	93960-R	93960-R	Tubing 5/32 Red	2 ft.

** – Refer to Fig. 66 for Breakdown

Basic Model 150

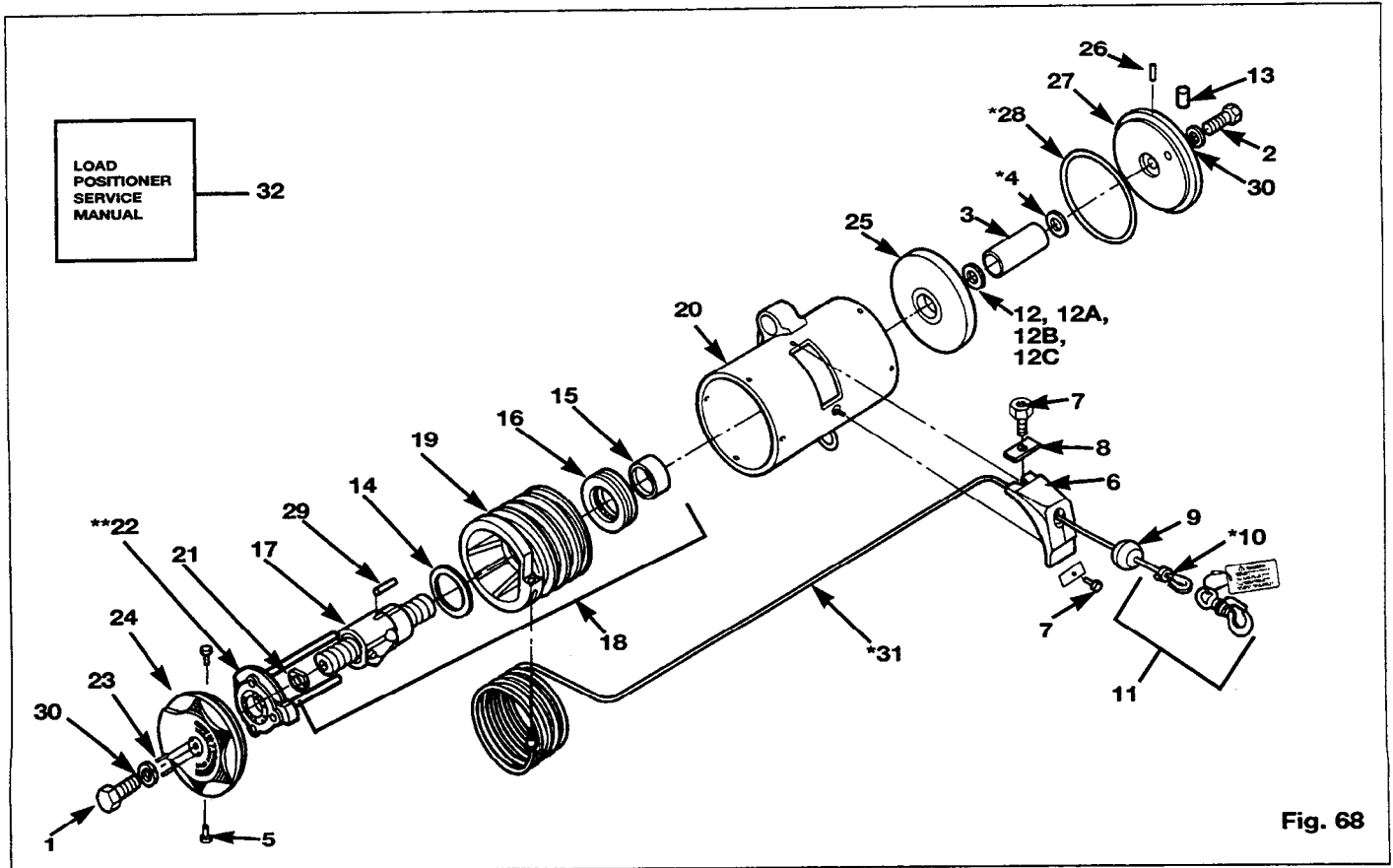

Fig. 68

150 LB. UNIT							
Item	Part #	Description	QTY.	Item	Part #	Description	QTY.
1	10017	Ball Screw Bolt (End Cover)	1	16	11091	Thrust Bearing	1
2	10013	Ball Screw Bolt (End Cap)	1	17	11112	Ball Screw Assy.	1
3	10046	Ball Screw Cap	1	18	11514	Ball Screw & Reel Assy.	1
4	*10061	Ball Screw Seal	1	19	11554	Reel Assy.	1
5	10071	Screw	2	20	12911	Housing Assy.	1
6	10116	Wire Rope Guide	1	21	13039	Bearing Retainer (Brake)	1
7	10124	Nut	2	22	**13110	Brake Assy.	1
8	10125	Wire Rope Guide Plate	2	23	13440	Anti-Rotation Pin	2
9	10165	Ball Stop Assy.	1	24	13703	End Cover Assy.	1
10	*10200	Swaged Stop	1	25	14502	Piston Assy.	1
11	10208	Accessory Kit	1	26	15037	End Cap Spring Pin	1
12	10415	.005 Shim	AS REQD.	27	13701	End Cap Assy.	1
12A	10416	.010 Shim	AS REQD.	28	*15520	O-Ring	1
12B	10417	.025 Shim	AS REQD.	29	16058	Ball Nut Dowel Pin	1
13	10764	Pipe Plug 1/4 NPT	1	30	74516	Washer	2
14	11076	Ball Nut Washer	1	31	*10084-20	Wire Rope 20 Ft.	1
15	11081	Thrust Bearing Retainer	1	32	MHD56141	Load Positioner Service Manual	1

* - Recommended Spare Parts Available in Kit 10590

** - Refer to Fig. 66 for Brake Assembly

Basic Model 200

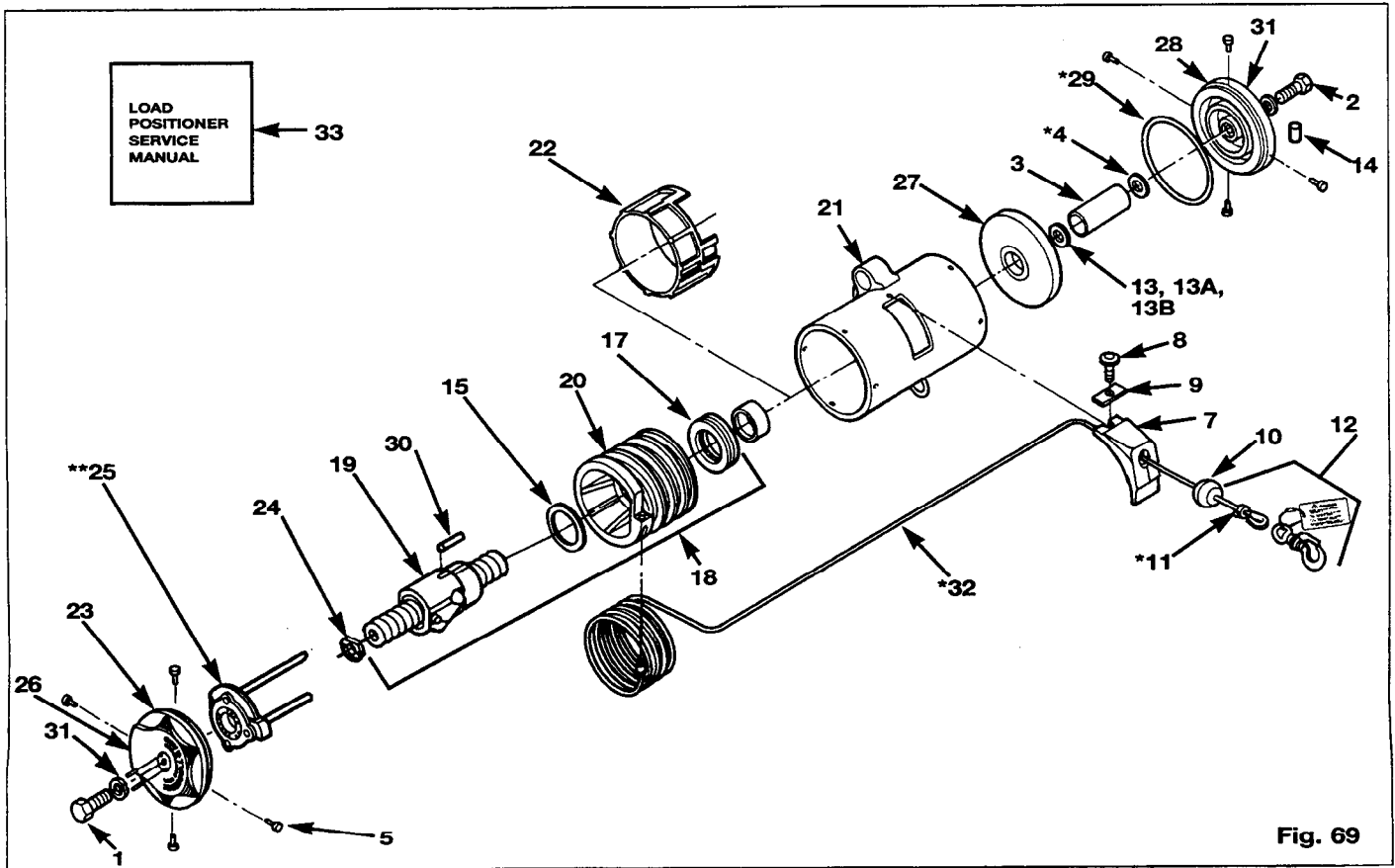

200 LB. UNIT							
Item	Part #	Description	QTY.	Item	Part #	Description	QTY.
1	10017	Ball Screw Bolt (End Cap)	1	17	11091	Thrust Bearing	1
2	10013	Ball Screw Bolt (End Cover)	1	18	11102	Ball Screw & Reel Assy.	1
3	10044	Ball Screw Cap	1	19	11112	Ball Screw Assy.	1
4	*10061	Ball Screw Seal	1	20	11125	Reel Assy.	1
5	10072	Screw	8	21	12204	Housing Assy.	1
7	10114	Wire Rope Guide	1	22	12225	Housing Liner	1
8	10120	Screw	1	23	13714	End Cover Assy.	1
9	10125	Wire Rope Guide Plate	1	24	13036	Bearing Retainer (Brake)	1
10	10165	Ball Stop Assy.	1	25	**13120	Brake Assy.	1
11	*10200	Swaged Stop	1	26	13440	Anti-Rotation Pin	2
12	10208	Accessory Kit	1	27	14005	Piston Assy.	1
13	10415	.005 Shim	AS REQD.	28	13711	End Cap	1
13A	10416	.010 Shim	AS REQD.	29	*15020	O-Ring	1
13B	10417	.025 Shim	AS REQD.	30	16058	Ball Nut Dowel Pin	1
14	10764	Pipe Plug 1/4 NPT	1	31	74516	Washer	2
15	11076	Ball Nut Washer	1	32	*10084-30	Wire Rope 30 Ft.	1
16	11081	Thrust Bearing Retainer	1	33	MHD56141	Load Positioner Service Manual	1

* - Recommended Spare Parts Available in Kit 10591

** - Refer to Fig. 66 for Brake Assembly

Basic Model 350

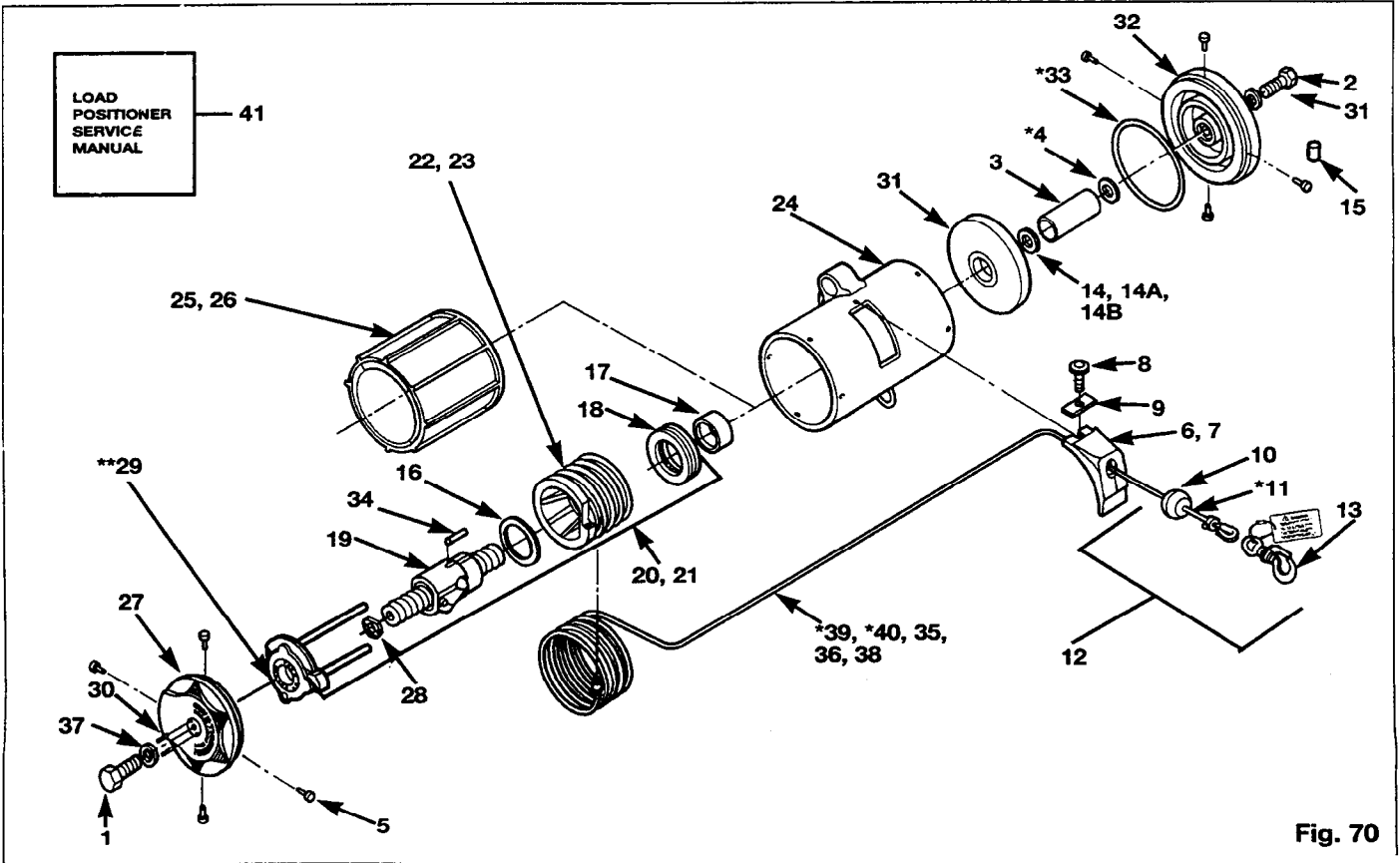

Fig. 70

350 LB. UNIT							
Item	Part #	Description	QTY.	Item	Part #	Description	QTY.
1	10013	Ball Screw Bolt (End Cover)	1	21	11517	Ball Screw & Reel Assy. (Chain)	1
2	10017	Ball Screw Bolt (End Cap)	1	22	11554	Reel Assy.	1
3	10048	Ball Screw Cap	1	23	11558	Reel Assy. (Chain)	1
4	*10061	Ball Screw Seal	1	24	12204	Housing Assy.	1
5	10072	Screw	8	25	12240	Liner Assy.	1
6	10113	Chain Guide	1	26	12249	Liner Assy. (Chain)	1
7	10115	Wire Rope Guide	1	27	13717	End Cover Assy.	1
8	10120	Screw	1	28	13039	Bearing Retainer (Brake)	1
9	10125	Wire Rope/Chain Guide Plate	1	29	**13135	Brake Assy.	1
10	10165	Ball Stop Assy.	1	30	13440	Anti-Rotation Pin	2
11	*10200	Swaged Stop	1	31	14005	Piston Assy.	1
12	10208	Accessory Kit	1	32	13711	End Cap	1
13	10224	Load Hook (Chain)	1	33	*15020	O-Ring	1
14	10415	.005 Shim	AS REQD.	34	16058	Ball Nut Dowel Pin	1
14A	10416	.010 Shim	AS REQD.	35	70485	Chain Anchor Screw	1
14B	10417	.025 Shim	AS REQD.	36	74503	Chain Anchor Washer	1
15	10764	Pipe Plug 1/4 NPT	1	37	74516	Washer	2
16	11076	Ball Nut Washer	1	38	75503	Chain Anchor Nut	1
17	11081	Thrust Bearing Retainer	1	39	*10084-30	Wire Rope 30 Ft.	1
18	11091	Thrust Bearing	1	40	*10109-20	Chain 20 Ft.	1
19	11112	Ball Screw Assy.	1	41	MHD56141	Load Positioner Service Manual	1
20	11514	Ball Screw & Reel Assy. (Wire Rope)	1				

* - Recommended Spare Parts Available in Kit 10591 (Wire Rope) 10592 (Chain)

** - Refer to Fig. 66 for Brake Assembly

Basic Model 500

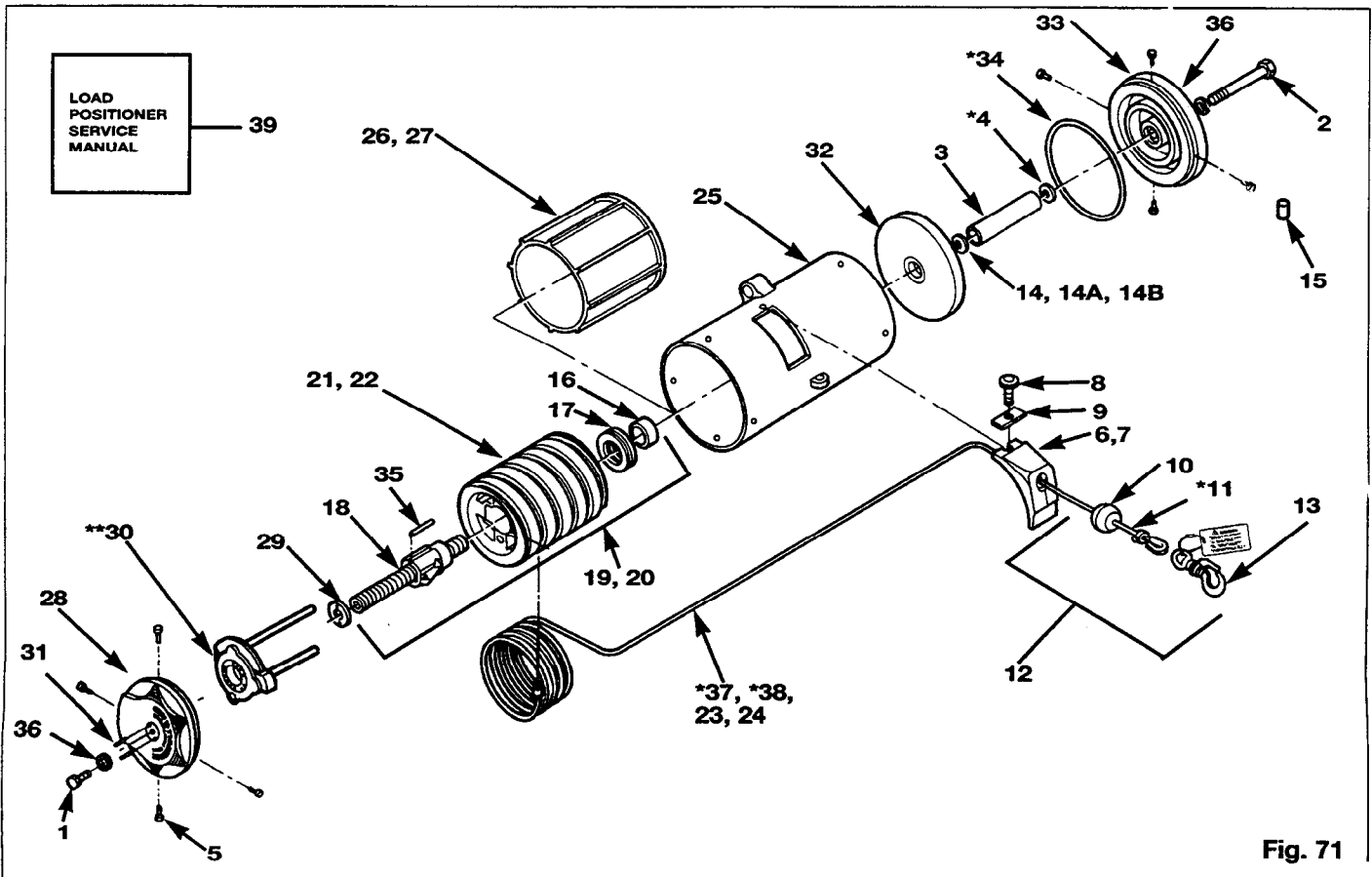

Fig. 71

500 LB. UNIT							
Item	Part #	Description	QTY.	Item	Part #	Description	QTY.
1	10017	Ball Screw Bolt (End Cover)	1	20	11516	Ball Screw & Reel Assy. (Wire Rope)	1
2	10018	Ball Screw Bolt (End Cap)	1	21	11546	Reel Assy.	1
3	10047	Ball Screw Cap	1	22	11548	Reel Assy. (Chain)	1
4	*10061	Ball Screw Seal	1	23	11555	Chain Anchor Screw	1
5	10072	Screw	8	24	11556	Chain Anchor Insert	1
6	10118	Wire Rope Guide	1	25	12208	Housing Assy.	1
7	10119	Chain Guide	1	26	12245	Liner Assy.	1
8	10120	Screw	1	27	12251	Liner Assy. (Chain)	1
9	10125	Wire Rope/Chain Guide Plate	1	28	13717	End Cover Assy.	1
10	10165	Ball Stop Assy.	1	29	13039	Bearing Retainer (Brake)	1
11	*10200	Swaged Stop	1	30	**13140	Brake Assy.	1
12	10208	Accessory Kit (Wire Rope)	1	31	13440	Anti-Rotation Pin	2
13	10224	Load Hook (Chain)	1	32	14005	Piston Assy.	1
14	10415	.005 Shim	AS REQD.	33	13711	End Cap	1
14A	10416	.010 Shim	AS REQD.	34	*15020	O-Ring	1
14B	10417	.025 Shim	AS REQD.	35	16058	Ball Nut Dowel Pin	1
15	10764	Pipe Plug 1/4 NPT	1	36	74516	Washer	2
16	11081	Thrust Bearing Retainer	1	37	*10084-30	Wire Rope 30 Ft.	1
17	11091	Thrust Bearing	1	38	*10109-20	Chain 20 Ft.	1
18	11115	Ball Screw Assy.	1	39	MHD56141	Load Positioner Service Manual	1
19	11515	Ball Screw & Reel Assy. (Chain)	1				

* - Recommended Spare Parts Available in Kit 10591 (Wire Rope) 10592 (Chain)

** - Refer to Fig. 66 for Brake Assembly

PARTS ORDERING INFORMATION

These units are designed and constructed to provide long, trouble-free service. In time it may become necessary to order and install new parts to replace those that have been subjected to wear.

The use of other than **Ingersoll-Rand** Material Handling replacement parts may result in decreased unit performance, and may invalidate the warranty. For prompt service and genuine **Ingersoll-Rand** Material Handling parts, provide your nearest Distributor with the following:

1. Complete unit model number and serial number as it appears on the nameplate.
2. Part number and part description as shown in this manual.
3. Quantity required.

M-SERIES LOAD POSITIONER **CE**

Model No.	edfghj
Capacity	456 lbs. @ 100psi
Serial No.	45678

INGERSOLL-RAND Ingersoll-Rand Company
MATERIAL HANDLING Lavergne, TN

The model and serial number label is located on the unit housing.

For your convenience and future reference it is recommended that the following information be recorded.

Model Number _____

Serial Number _____

Date Purchased _____

Return Goods Policy

If it becomes necessary to return the complete unit or certain parts to the factory, contact the Distributor from whom you purchased the unit, or the nearest **Ingersoll-Rand** Distributor in your locality, **Ingersoll-Rand** will not accept any returned goods for warranty or service work unless prior arrangements have been made and written authorization has been provided from the location where the goods were purchased.

NOTICE

- **Continuing improvement and advancement of design may cause changes to this unit which are not included in this manual. Manuals are periodically revised to incorporate changes. Always check the manual edition number on the front cover for the latest issue.**

Disposal

When the life of the unit has expired, it is recommended that the unit be disassembled, degreased and parts separated as to materials so that they may be recycled.

For Additional Information Contact:

Ingersoll-Rand Co.
Distribution Center
510 Hester Drive
P.O. Box 618
White House, TN 37188
Phone: (615) 672-0321
Fax: (615) 672-0854

LIMITED WARRANTY

Ingersoll-Rand Company (I-R) warrants to the original user its Hoists and Winches (Products) to be free of defects in material and workmanship for a period of one year from the date of purchase. I-R will repair, without cost, any Product found to be defective, including parts and labor charges, or at its option, will replace such Products or refund the purchase price less a reasonable allowance for depreciation, in exchange for the Product. Repairs or replacements are warranted for the remainder of the original warranty period.

If any Product proves defective within its original one year warranty period, it should be returned to any Authorized Hoist and Winch Service Distributor, transportation prepaid with proof of purchase or warranty card.

This warranty does not apply to Products which I-R has determined to have been misused or abused, improperly maintained by the user, or where the malfunction or defect can be attributed to the use of non-genuine I-R parts.

I-R makes no other warranty, and all implied warranties including any warranty of merchantability or fitness for a particular purpose are limited to the duration of the expressed warranty period as set forth above. I-R's maximum liability is limited to the purchase price of the Product and in no event shall I-R be liable for any consequential, indirect, incidental, or special damages of any nature rising from the sale or use of the Product, whether based on contract, tort, or otherwise.

Note: Some states do not allow limitations on incidental or consequential damages or how long an implied warranty lasts so that the above limitations may not apply to you.

This warranty gives you specific legal rights and you may also have other rights which may vary from state to state.

IMPORTANT NOTICE

It is our policy to promote safe delivery of all orders.

This shipment has been thoroughly checked, packed and inspected before leaving our plant and receipt for it in good condition has been received from the carrier. Any loss or damage which occurs to this shipment while enroute is not due to any action or conduct of the manufacturer.

VISIBLE LOSS OR DAMAGE

If any of the goods called for on the bill of lading or express receipt are damaged or the quantity is short, do not accept them until the freight or express agent makes an appropriate notation on your freight bill or express receipt.

CONCEALED LOSS OR DAMAGE

When a shipment has been delivered to you in apparent good condition, but upon opening the crate or container, loss or damage has taken place while in transit, notify the carrier's agent immediately.

DAMAGE CLAIMS

You must file claims for damage with the carrier. It is the transportation company's responsibility to reimburse you for repair or replacement of goods damaged in shipment. Claims for loss or damage in shipment must not be deducted from the **Ingersoll-Rand** invoice, nor should payment of **Ingersoll-Rand** invoice be withheld awaiting adjustment of such claims as the carrier guarantees safe delivery.

You may return products damaged in shipment to us for repair, which services will be for your account and form your basis for claim against the carrier.

Notes:

For Order Entry, Order Status
and Technical Support:
Ingersoll-Rand
Distribution Center
510 Hester Drive
P.O. Box 618
White House, TN 37188
Phone: (615) 672-0321
Fax: (615) 672-0854

©1997 Ingersoll-Rand Company
Printed In U.S.A.