

PARTS, OPERATION AND MAINTENANCE MANUAL

THIRD GENERATION

force **AIR WINCHES**

MODEL FA2A

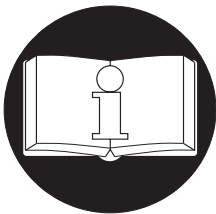

READ THIS MANUAL BEFORE USING THESE PRODUCTS. This manual contains important safety, installation, operation and maintenance information. Make this manual available to all persons responsible for the operation, installation and maintenance of these products.

⚠ WARNING

Do not use this winch for lifting, supporting, or transporting people or lifting or supporting loads over people.

Always operate, inspect and maintain this winch in accordance with American National Standards Institute Safety Code (ASME B30.7) and any other applicable safety codes and regulations.

Refer all communications to the nearest Ingersoll-Rand Material Handling Office or Distributor.

CONTENTS

	Page
Safety Information	
Danger, Warning, Caution and Notice	3
Safe Operating Instructions	4
Warning Labels and Tag	4
Specifications	
Description	5
Model Code Explanation	5
General Specifications	6
Winch Weight and Wire Rope Capacities	6
Performance Graphs	7
Installation	
Mounting	8
Wire Rope	8
Air Supply	10
Motor	11
Initial Operating Checks	11
Operation	
Winch Controls	12
Brakes	13
Free Spool	14
Inspection	
Records and Reports	15
Wire Rope Reports	15
Frequent Inspection	15
Periodic Inspection	16
Winches Not in Regular Use	16
Inspection and Maintenance Report Form	17
Troubleshooting	18
Lubrication	19
Maintenance	
Thermoplastic Coating	21
Adjustments	22
Disassembly	22
Cleaning, Inspection and Repair	27
Assembly	28
Testing	35
Parts Section	
Winch Parts Drawings and Parts Lists Table of Contents	36
Winch Cross Section Drawing	37
Winch Parts Drawings and Parts Lists	38 - 61
Parts Ordering Information	62
Warranty	63
Office Locations	64

SAFETY INFORMATION

This manual provides important information for all personnel involved with the safe installation, operation and proper maintenance of this product. Even if you feel you are familiar with this or similar equipment, you should read this manual before operating the winch.

Danger, Warning, Caution and Notice

Throughout this manual there are steps and procedures which, if not followed, may result in an hazard. The following signal words are used to identify the level of potential hazard.

DANGER

Danger is used to indicate the presence of a hazard which *will* cause *severe* injury, death, or substantial property damage if the warning is ignored.

WARNING

Warning is used to indicate the presence of a hazard which *can* cause *severe* injury, death, or substantial property damage if the warning is ignored.

CAUTION

Caution is used to indicate the presence of a hazard which *will* or *can* cause injury or property damage if the warning is ignored.

NOTICE

Notice is used to notify people of installation, operation, or maintenance information which is important but not hazard-related.

Safety Summary

WARNING

- Do not use this winch for lifting, supporting, or transporting people or lifting or supporting loads over people.
- The supporting structures and load-attaching devices used in conjunction with this winch must provide an adequate safety factor to handle the rated load, plus the weight of the winch and attached equipment. This is the customer's responsibility. If in doubt, consult a registered structural engineer.

Ingersoll-Rand Material Handling winches are manufactured in accordance with the latest ASME B30.7 standards.

The National Safety Council, Accident Prevention Manual for Industrial Operations, Eighth Edition and other recognized safety sources make a common point: Employees who work near suspended loads or assist in hooking on or arranging a load should be instructed to keep out from under the load. From a safety standpoint, one factor is paramount: conduct all lifting or pulling operations in such a manner that if there were an equipment failure, no personnel would be injured. This means keep out from under a raised load and keep out of the intended path of any load.

The Occupational Safety and Health Act of 1970 generally places the burden of compliance with the user, not the manufacturer. Many OSHA requirements are not concerned or connected with the manufactured product but are, rather, associated with the final installation. It is the owner's and user's responsibility to determine the suitability of a product for any particular use. It is recommended that all applicable industry, trade association, federal, state and local regulations be checked. Read all operating instructions and warnings before operation.

Rigging: It is the responsibility of the operator to exercise caution, use common sense and be familiar with proper rigging techniques. See ASME B30.9 for rigging information, American National Standards Institute, 1430 Broadway, New York, NY 10018.

This manual has been produced by **Ingersoll-Rand** to provide dealers, mechanics, operators and company personnel with the information required to install, operate, maintain and repair the products described herein.

It is extremely important that mechanics and operators be familiar with the servicing procedures of these products, or like or similar products, and are physically capable of conducting the procedures. These personnel shall have a general working knowledge that includes:

1. Proper and safe use and application of mechanics common hand tools as well as special **Ingersoll-Rand** or recommended tools.
2. Safety procedures, precautions and work habits established by accepted industry standards.

Ingersoll-Rand cannot know of, or provide all the procedures by which product operations or repairs may be conducted and the hazards and/or results of each method. If operation or maintenance procedures not specifically recommended by the manufacturer are conducted, it must be ensured that product safety is not endangered by the actions taken. If unsure of an operation or maintenance procedure or step, personnel should place the product in a safe condition and contact supervisors and/or the factory for technical assistance.

SAFE OPERATING INSTRUCTIONS

The following warnings and operating instructions have been adapted in part from American National (Safety) Standard ASME B30.7 and are intended to avoid unsafe operating practices which might lead to injury or property damage.

Ingersoll-Rand recognizes that most companies who use winches have a safety program in force at their facility. In the event that some conflict exists between a rule set forth in this publication and a similar rule already set by an individual company, the more stringent of the two should take precedence.

Safe Operating Instructions are provided to make an operator aware of dangerous practices to avoid and are not necessarily limited to the following list. Refer to specific sections in the manual for additional safety information.

1. Only allow people, trained in safety and operation of this product, to operate and maintain this winch.
2. Only operate a winch if you are physically fit to do so.
3. When a **“DO NOT OPERATE”** sign is placed on the winch, or controls, do not operate the winch until the sign has been removed by designated personnel.
4. Before each shift, the operator should inspect the winch for wear and damage. Never use a winch that inspection indicates is worn or damaged.
5. Never lift a load greater than the rated capacity of the winch. Refer to nameplate attached to winch and to **“SPECIFICATIONS”** section.
6. Keep hands, clothing, etc., clear of moving parts.
7. Never place your hand in the throat area of a hook or near wire rope spooling onto or off of the winch drum.
8. Always rig loads properly and carefully.
9. Be certain the load is properly seated in the saddle of the hook. Do not support the load on the tip of the hook.
10. Do not **“side pull”** or **“yard”**.
11. Always ensure that you, and all other people, are clear of the path of the load. Do not lift a load over people.
12. Never use the winch for lifting or lowering people, and never allow anyone to stand on a suspended load.
13. Ease the slack out of the wire rope when starting a lift or pull. Do not jerk the load.
14. Do not swing a suspended load.
15. Do not leave a suspended load unattended.
16. Never operate a winch with twisted, kinked or damaged wire rope.
17. Pay attention to the load at all times when operating the winch.
18. Never use the wire rope as a sling.
19. After use, or when in a non-operational mode, the winch should be secured against unauthorized and unwarranted use.

WARNING LABELS AND TAG

Each unit is shipped from the factory with the warning labels and tag shown. If the labels or tag are not attached to your unit, order new labels and tag and install. See the parts list for the part numbers. Labels and tag shown smaller than actual size.

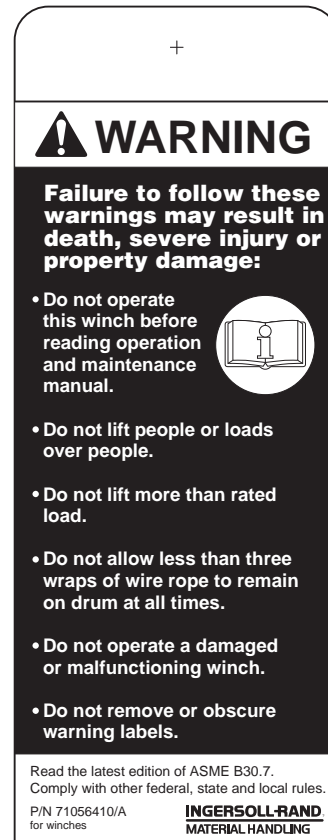

SPECIFICATIONS

Description

FA2A winches are air powered, planetary geared units designed for lifting and pulling applications. **FA2A** winches are supplied with either an internal automatic disc brake, a manual or automatic externally mounted drum band brake, or a combination of both. The output from an externally mounted piston air motor is transmitted through a coupling and shaft to the planetary reduction gear assembly. The output from the planetary reduction gear assembly is connected to the wire rope drum through the output shaft. The disc brake attaches to the outboard upright opposite the motor end and is connected to the intermediate sun gear through the brake shaft. The disc brake is automatically applied when the winch is in the neutral or operated in the haul-in positions; disengaged when the winch is operated in the payout direction.

During winch operation a sprag type clutch in the disc brake allows drum rotation in the haul-in direction with the disc brake engaged. This ensures the brake will respond quickly to hold the load when winch operation stops. Operation of the winch in the payout direction directs pressurized air to the disc brake diaphragm to overcome spring tension and release the brake. When the payout operation is complete the air is vented and the brake is automatically applied. The drum band brake operates by applying a friction force between the drum band and the winch drum. The manual brake requires an operator to engage and disengage the brake using a handle located near the air motor end of the winch. The automatic drum band brake operation is similar to the disc brake with the following exception: the automatic drum band brake fully disengages in both the haul-in and payout directions.

Model Code Explanation: (Example FA2A-LXK1G)

FA 2 A - L X K 1 G

Series:

FA = Force 5 Air Powered

Capacity: (Based on wire rope at mid drum)

2 = 2 tons (4,000 lb [1,814 kg])

Generation:

A = Third Generation

Drum Length: (Refer to drum length chart)

- S = Short (7 inches [178 mm])
- M = Medium (13-1/2 inches [343 mm])
- L = Long (20 inches [508 mm])
- R = Extra long (24 inches [610 mm])

Drum Brake:

- A = Automatic Drum Brake *
- M = Manual Drum Brake *
- X = None

Disc Brake:

- K = Automatic Disc Brake (Standard)
- X = None

Control:

- 1 = Winch mounted lever throttle (Standard)
- ** 2 = Remote pilot pendant throttle with standard length 6 foot (1.8 metre) hose
- *** 2XX = Remote pilot lever throttle (XX = Specify hose length (feet); maximum 60 feet [18.3 m])

Options:

- | | |
|---|--|
| <ul style="list-style-type: none"> F = Free spool clutch (available only with manual drum brake) H = Open Front Frame for horizontal pulling K = K6U footprint base **** T = Tensioning Manifold **** U = Underwound wire rope operation 7 = Drum grooving (specify rope size in sixteenths: 7 = 7/16 inch wire rope) **** -E = Compliance with European Community Machinery Directive: <ul style="list-style-type: none"> • Muffler • Overload Device • Main air supply emergency shutoff • Drum Guard • CE Documentation | <ul style="list-style-type: none"> G = Drum Guard S = Limit Switch (upper and lower) **** L = Drum Locking Pin **** D = Drum divider flange and additional wire rope anchor **** |
|---|--|

Notes:

- * Addition of drum brake increases the overall winch length 2.75 inches (70 mm).
- ** Available only with auto disc brake and/or with auto drum brake.
- *** Remote throttles are provided with 6 feet (1.8 metres) of hose. Specify hose lengths greater than 6 feet. Contact your Ingersoll-Rand distributor or the factory for control acceptability for hose lengths greater than 60 feet (18.3 metres). Metric lengths are provided for reference only, order lengths in feet.
- **** Feature not covered in this manual; contact factory for additional information.

Winch Models FA2A General Specifications		With Full 380 SCFM Air Supply		With 185 SCFM Portable Air Compressor Supply *	
Air System	Rated Operating Pressure	90 psig (6.3 bar/630 kPa)			
	Air Consumption (at rated pressure and load)	380 scfm	10.8 cu.m/min	185 scfm	5.24 cu.m/min
Rated Performance (at rated pressure / volume)	Mid Drum Line Pull	4,000 lbs	1,814 kg	4,000 lbs	1,818 kg
	Mid Drum Line Speed	150 fpm	46 metres/min	115 fpm	35 metres/min
Air Motor Pipe Inlet Size		1-1/4 inch NPT	1-1/4 inch NPT	1-1/4 inch NPT	1-1/4 inch NPT
Minimum Air System Hose Size		1 inch	25.4 mm	1 inch	25.4 mm
Drum Barrel Diameter		9.25 inches	235 mm	9.25 inches	235 mm
Drum Flange Diameter		17 inches	432 mm	17 inches	432 mm

* When used in applications as a replacement for the HU40 winch.

Winch Net Weight (without wire rope)

Model	lbs	kg	Model	lbs	kg
FA2A-SXK1	590	268	FA2A-SXK2	593	269
FA2A-SMK1	648	294	FA2A-SMK2	651	295
FA2A-SAK1	670	304	FA2A-SAK2	673	305
FA2A-SMX1	613	278	N/A	N/A	N/A
FA2A-SAX1	635	288	FA2A-SAX2	638	289
FA2A-MXK1	630	286	FA2A-MXK2	633	287
FA2A-MMK1	688	312	FA2A-MMK2	691	313
FA2A-MAK1	710	322	FA2A-MAK2	713	323
FA2A-MMX1	653	296	N/A	N/A	N/A
FA2A-MAX1	675	306	FA2A-MAX2	678	308
FA2A-LXK1	670	304	FA2A-LXK2	673	305
FA2A-LMK1	728	330	FA2A-LMK2	731	332
FA2A-LAK1	750	340	FA2A-LAK2	753	342
FA2A-LMX1	693	314	N/A	N/A	N/A
FA2A-LAX1	715	324	FA2A-LAX2	718	326
FA2A-RXK1	Contact Factory		FA2A-RXK2	Contact Factory	
FA2A-RMK1			FA2A-RMK2		
FA2A-RAK1			FA2A-RAK2		
FA2A-RMX1			N/A		
FA2A-RAX1			FA2A-RAX2		

Winch Wire Rope Storage Capacities (feet/metres)

Drum Length		Storage Notes	Wire Rope Diameter							
			3/8 inch	10 mm	7/16 inch	11 mm	1/2 inch	13 mm	5/8 inch	16 mm
inches	mm		feet	metres	feet	metres	feet	metres	feet	metres
7	178	Full Drum Storage less 2 wire rope layers	448	137	335	102	248	76	124	38
13-1/2	343		888	271	666	203	495	151	251	77
20	508		1,328	405	998	304	743	227	378	115
24	610		1,598	487	1,200	366	895	273	456	139
7	178	Full Drum Storage less 1/2 inch (13 mm) (per ASME B30.7)	519	158	396	121	300	91	164	50
13-1/2	343		1,029	314	788	240	600	183	330	101
20	508		1,538	469	1,180	360	900	274	497	152
24	610		1,851	564	1,388	423	1,085	331	599	133
7	178	Full Drum Storage	593	181	460	140	356	109	206	63
13-1/2	343		1,176	359	915	279	712	217	416	127
20	508		1,758	536	1,371	418	1,068	326	625	191
24	610		2,116	645	1,587	484	1,287	392	754	230

FA2A Performance Curve with 380 scfm (10.8 cu. m/m) Air Supply:

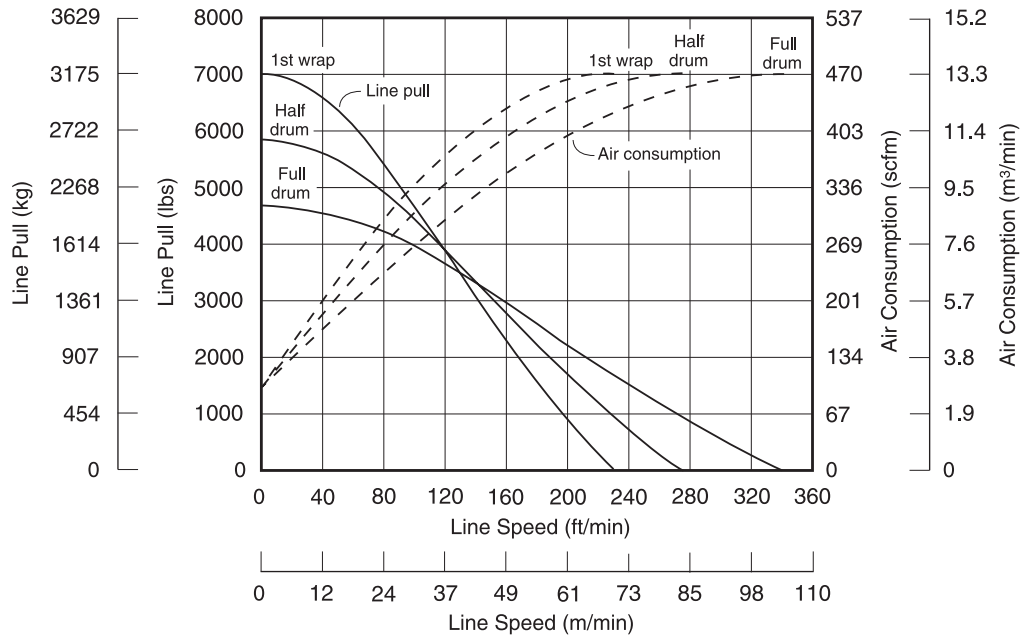

FA2A Performance Curve with 185 scfm (5.24 cu. m/m) Air Supply (Portable Compressor):

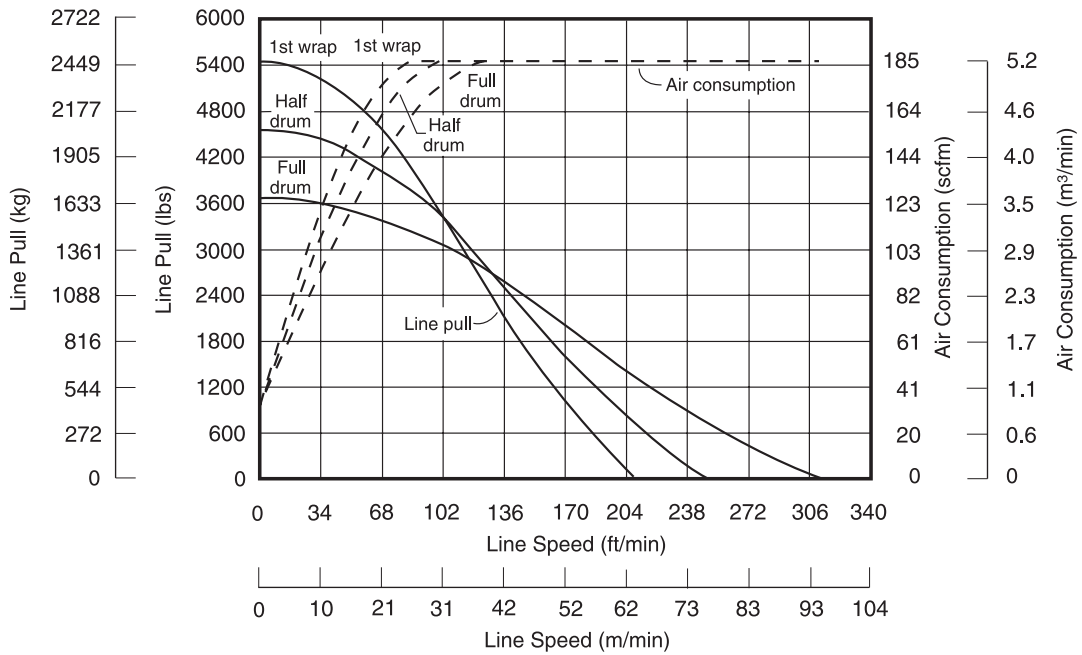

(Dwg. MHP1275)

INSTALLATION

Prior to installing the winch, carefully inspect it for possible shipping damage. Winches are supplied fully lubricated from the factory. Check oil levels and adjust as necessary before operating winch. Refer to “LUBRICATION” section for recommended oils.

⚠ CAUTION

• **Owners and users are advised to examine specific, local or other regulations, including American National Standards Institute and/or OSHA Regulations which may apply to a particular type of use of this product before installing or putting winch to use.**

Mounting

Refer to Dwg. MHP0124 and Table 1. Care must be taken when moving, positioning or mounting the winch. Ensure that the winch, when lifted, will be properly balanced. Determine the weight of the winch by referring to the “SPECIFICATIONS” section. Lift the winch 3 to 4 inches (75 to 100 mm) off the ground. Verify winch is balanced and secure before continuing lift. Mount the winch so the axis of the drum is horizontal and the motor control valve pad is not more than 15° off top vertical center. If the winch is to be mounted in an inverted position, the motor case must be rotated to position the control valve pad at the top and adequate clearance must be provided for control valve operation.



⚠ WARNING

• **Winch frame material is not suitable for welding, FA2A winches must only be mounted by bolting to a suitable foundation. Do not attempt to mount the winch by welding to a foundation structure.**

1. The winch mounting surface must be flat and of sufficient strength to handle the rated load plus the weight of the winch and attached equipment. An inadequate foundation may cause distortion or twisting of the winch uprights and side rails resulting in winch damage.
2. Make sure the mounting surface is flat to within 1/32 inch (0.8 mm). Shim if necessary.
3. Mounting bolts must be 3/4 inch-NC (18 mm) Grade 8 or better. Use self-locking nuts or nuts with lockwashers.

4. Tighten mounting bolts evenly and torque to 380 ft lbs (515 Nm) for dry thread fasteners. If the fasteners are plated, lubricated or a thread locking compound is used, torque to 280 ft lbs (380 Nm).
5. Maintain a fleet angle between the lead sheave and winch of no more than 1-1/2°. The lead sheave must be on a center line with the drum and, for every inch (25 mm) of drum length, be at least 1.6 feet (0.5 metre) from the drum. Refer to Dwg. MHP0498.
6. Do not weld to any part of the winch.

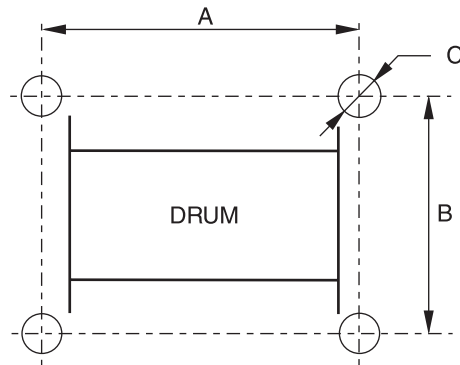

(Dwg. MHP0124)

Table 1: Mounting Bolt Hole Dimensions

Dimension	Drum Length (inches)								
	Without Drum Brake				With Drum Brake				
	7	13.5	20	24	7	13.5	20	24	
“A”	in.	9.54	16.04	22.54	26.54	12.31	18.81	25.31	29.31
	mm	242	408	573	674	313	478	643	744
“B”	in.	15							
	mm	381							
“C”	in.	0.81							
	mm	20.6							

Wire Rope

⚠ CAUTION

• **Maintain at least 3 tight wraps of wire rope on the drum at all times. Refer to Dwg. MHP0498.**

Install the winch such that the wire rope, when at the take-off angle limits, shown in Dwg. MHP1013, does not contact the mounting surface.

⚠ DANGER

• **Exceeding the wire rope take-off angles will cause the wire rope to come into contact with the winch frame supports resulting in damage to the wire rope and winch.**

Wire Rope Selection

Consult a reputable wire rope manufacturer or distributor for assistance in selecting the appropriate type and size of wire rope and, where necessary, a protective coating. Use a wire rope which provides an adequate safety factor to handle the actual working load and that meets all applicable industry, trade association, federal, state and local regulations.

When considering wire rope requirements the actual working load must include not only the static or dead load but also loads resulting from acceleration, retardation and shock load.

Consideration must also be given to the size of the winch wire rope drum, sheaves and method of reeving. Wire rope construction must be 1/2 inch (13 mm) EIPS 6 X 19 IWRC with a minimum breaking strength of 26,600 lb. (12,091 kg) right lay to permit correct installation of wire rope anchor. Wire rope construction providing a non-rotating or anti-spin characteristic is recommended. Refer to Table 2 for recommended wire rope sizes.

FA2A Standard Wire Rope Take-Off Angle(s):

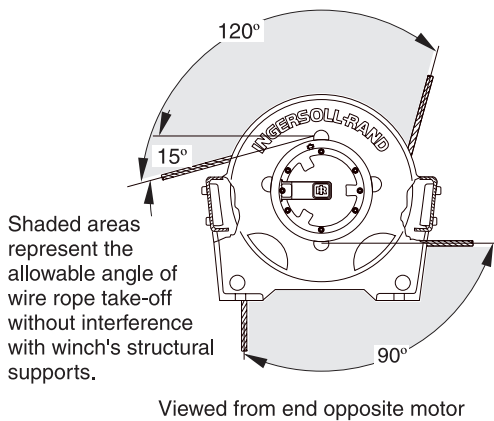

FA2A Open Frame (Face) Wire Rope Take-Off Angle(s):

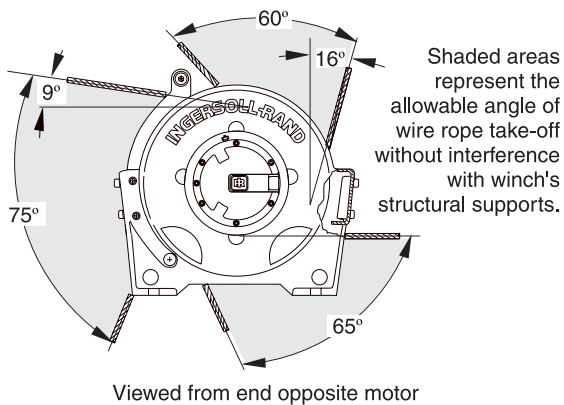

(Dwg. MHP1013)

Table 2: Wire Rope Size

Wire Rope Anchor Part No.	Minimum		Maximum	
	inch	mm	inch	mm
25539	3/8	10	5/8	16

Note: To maintain 5:1 safety factor ratio 1/2 inch (12 mm) wire rope must be used.

Installing Wire Rope

Refer to Dwg. MHP0652.

1. Cut wire rope to length and fuse end to prevent fraying of strands in accordance with the wire rope manufacturer's instructions.
2. Feed the end of the wire rope into the wire rope anchor hole in the drum and pull through approximately three feet (1 metre) of wire rope.
3. Forming a large loop with the wire rope, insert the end back into the top of the anchor hole.
4. Place the wire rope wedge into the wire rope anchor pocket in the drum. Install the wedge such that the wire rope will wrap around the wedge as shown in Dwg. MHP0652.
5. Pull the wire rope into position in the drum anchor pocket. Ensure the wire rope is installed below the edge of the drum flange diameter. Use of a copper drift or similar tool may be required to fully insert wire rope and wedge into the anchor pocket.

CAUTION

- Make sure the first wrap of wire rope is tight and lays flush against the drum flange.
- Ensure the correct wire rope anchor is used.
- Install wire rope to come off the drum in an overwind position. Improper installation of wire rope can result in failure of the disc brake to hold load. Refer to Dwg. MHP0652.

Safe Wire Rope Handling Procedures

1. Always use gloves when handling wire rope.
2. Never use wire rope which is frayed or kinked.
3. Never use wire rope as a sling.
4. Always ensure wire rope is correctly spooled and the first layer is tight against the drum.
5. Always follow wire rope manufacturer's recommendations on use and maintenance of wire rope.

Wire Rope Installation Drawing

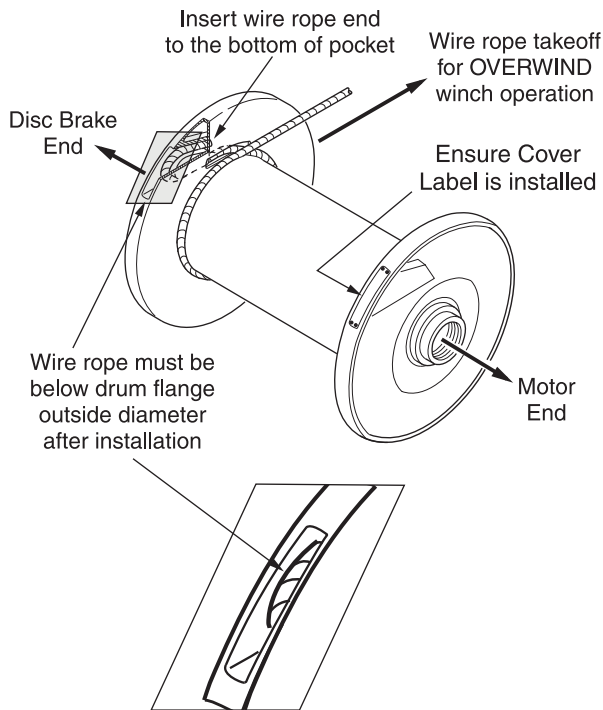

(Dwg. MHP0652)

Wire Rope and Fleet Angle Installation Drawing

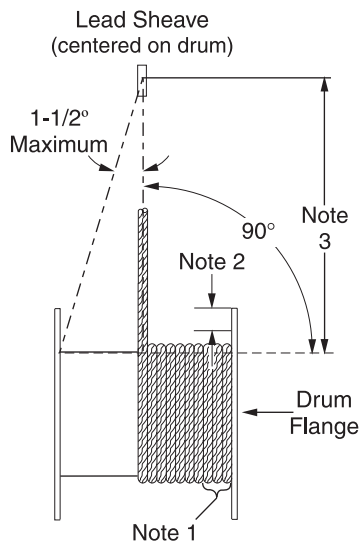

(Dwg. MHP0498)

Notes:

1. Maintain a minimum of 3 tight wraps of wire rope on drum at all times.
2. Ensure wire rope does not exceed top layer requirement. Refer to "SPECIFICATIONS" section.
3. For correct fleet angle maintain a minimum of 1.6 feet (0.5 metre) per inch of drum length. Example: for 7 inch drum length locate lead sheave at least 11.2 feet (3.5 metres) from drum.

Wire Rope Spooling

To compensate for uneven spooling and the decrease in line pull capacity as the drum fills up, use as short a wire rope as practical. When rewinding apply tension to the end of the wire rope to eliminate line slack. This helps achieve level winding and tight spooling.

Rigging

Make sure all wire rope blocks, tackle and fasteners have a sufficient safety margin adequate enough to handle the required load under all conditions. Do not allow wire rope to contact sharp edges or make sharp bends which will cause damage to wire rope, **use a sheave**. Refer to the wire rope manufacturer's handbook for proper sizing, use and care of wire rope.

Safe Installation Procedures

1. Do not use wire rope as a ground (earth) for welding.
2. Do not attach a welding electrode to winch or wire rope.
3. Never run the wire rope over a sharp edge. Use a correctly sized sheave.
4. When a lead sheave is used, it must be aligned with the center of the drum. The diameter of the lead sheave must be at least 18 times the diameter of the wire rope. Refer to Dwg. MHP0498.
5. Always maintain at least three full, tight wraps of wire rope on the drum.

Air Supply

The air supply must be clean, free from moisture and lubricated to ensure optimum motor performance. Foreign particles, moisture and lack of lubrication are the primary causes of premature motor wear and breakdown. Using an air filter, lubricator and moisture separator will improve overall winch performance and reduce unscheduled down time.

The air consumption is 380 scfm (10.8 cu. m/min) at rated operating pressure of 90 psig (6.3 bar/630 kPa) at the winch motor inlet. If air supply varies from recommended, then winch performance will change.

Air Lines

The inside diameter of the winch air supply lines must be at least 1 inch (25.4 mm). Before making final connections, all air supply lines should be purged with clean, moisture free air or nitrogen before connecting to winch inlet. Supply lines should be as short and straight as installation conditions will permit. Long transmission lines and excessive use of fittings, elbows, tees, globe valves etc. cause a reduction in pressure due to restrictions and surface friction in the lines.

Air Line Lubricator

Refer to Dwg. MHP0191.

Always use an air line lubricator with these motors. The lubricator must have an inlet and outlet at least as large as the inlet on the motor directional control valve. Install the air line lubricator as close to the air inlet on the motor as possible.

CAUTION

- Lubrication for the FA2A motor must be provided in the supply air. Ensure an inline lubricator is installed before operating the winch motor.
- Lubricator must be located no more than 10 ft. (3 m) from the motor.
- Shut off air supply before filling air line lubricator.

The air line lubricator should be replenished daily and set to provide 3 drops per minute of ISO VG 32 (10W) oil.

Air Line Filter

Refer to Dwg. MHP0191.

Place the strainer/filter as close as practical to the motor air inlet port, but upstream from the lubricator, to prevent dirt from entering the motor. The filter/strainer should provide 20 micron filtration and include a moisture trap. Clean the filter/strainer periodically to maintain its operating efficiency.

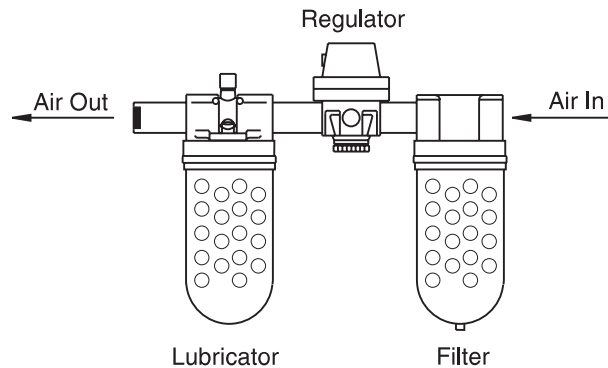

(Dwg. MHP0191)

Air Pressure Regulator

Refer to Dwg. MHP0191.

If an air pressure regulator is used, install between the lubricator and filter as shown in Dwg. MHP0191.

Moisture in Air Lines

Moisture that reaches the air motor through air supply lines is a primary factor in determining the length of time between service overhauls. Moisture traps can help to eliminate moisture. Other methods, such as an air receiver which collects moisture before it reaches the motor, or an aftercooler at the compressor that cools the air to condense and collect moisture prior to distribution through the supply lines are also helpful.

Mufflers

Make sure mufflers are installed in winch exhaust manifold and control valve exhaust port. An additional muffler is used on winches equipped with an emergency stop and overload device. Check mufflers periodically to ensure they are functioning correctly.

Motor

For optimum performance and maximum durability of parts, provide a lubricated air supply of 380 scfm (10.8 cu. m/min) at 90 psig (6.3 bar/630 kPa). The air motor should be installed as near as possible to the compressor or air receiver. Recommended pressures and volumes are measured at the point of entry to the air motor directional control valve.

Initial Winch Operating Checks

Winches are tested for proper operation prior to leaving the factory. Before the winch is placed into service the following initial operating checks should be performed.

1. When first running the motor inject some light oil into the inlet connection to provide initial lubrication.
2. When first operating the winch it is recommended that the motor be driven slowly in both directions for a few minutes.

For winches that have been in storage the following start-up procedures are required.

1. Give the winch an inspection conforming to the requirements of "Winches Not in Regular Use" in the "INSPECTION" section.
2. Pour a small amount of ISO VG 32 (10W) oil in the motor inlet port.
3. Operate the motor for 10 seconds in both directions to flush out any impurities.
4. Check to ensure oil levels are "full".
5. The winch is now ready for normal use.

OPERATION

It is recommended that the user and owner check all appropriate and applicable regulations before placing this product into use.

The four most important aspects of winch operation are:

1. Follow all safety instructions when operating the winch.
2. Allow only people trained in safety and operation of this winch to operate this equipment.
3. Subject each winch to a regular inspection and maintenance procedure.
4. Be aware of the winch capacity and weight of load at all times.

⚠ CAUTION

• **To avoid damage to the rigging, the structure supporting the rigging and the winch, do not “two-block” the end of the wire rope.**

* Two blocking occurs when the winch wire rope is multi reeved using two separate sheave blocks which are allowed to come into contact with each other during winch operation. When this occurs extreme forces are exerted on the wire rope and sheave blocks which may result in equipment and or rigging failure.

⚠ WARNING

• **The winch is not designed or suitable for lifting, lowering or moving people. Never lift loads over people.**

Operators must be physically competent. Operators must not have a health condition which might affect their ability to act, and they must have good hearing, vision and depth perception. The winch operator must be carefully instructed in his duties and must understand the operation of the winch, including a study of the manufacturer’s literature. The operator must thoroughly understand proper methods of hitching loads and must have a good attitude regarding safety. It is the operator’s responsibility to refuse to operate the winch under unsafe conditions.

Winch Controls

A spring loaded, motor mounted, manual throttle control valve is supplied as a standard feature on these winches. Optional remote pendant controls are also available. Reference the model code on the winch nameplate and compare it to the “SPECIFICATIONS” section of this manual to determine winch configuration. The throttle control provides operator control of the motor speed and direction of drum rotation. Operate winch throttle control using smooth, even movements. Do not slam or jerk throttle controls during operation.

🔧 Winch Mounted Air Throttle

Refer to Dwg. MHP0566.

The spring loaded, live air, manual control throttle valve mounts to the air motor.

As viewed from the air motor end, move the control throttle handle to the right (clockwise) to payout wire rope and to the left (counterclockwise) to haul-in wire rope. Avoid sudden movements of the control valve to ensure smooth operation of the winch.

When winch is not in use, engage handle latch to prevent inadvertent movement of the control throttle.

Winch Mounted Throttle Control Valve

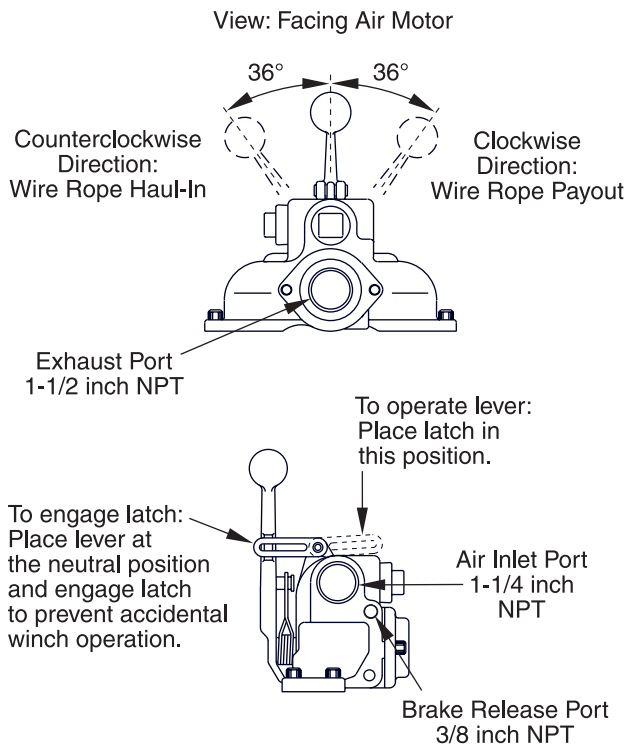

(Dwg. MHP0566)

🔧 Remote Control Pendant without Emergency Stop

Optional feature. Refer to Dwg. MHP1311.

Provides for remote winch control at distances up to 60* feet (18 metres) away from the winch motor. Pilot air hoses connect the pendant to the winch motor pilot air valve to provide winch operation. The pendant control is a two lever movable control station which controls payout and haul-in.

Direction of winch drum rotation is determined by the pendant lever depressed. Air is directed from the pendant into the pilot valve. The pilot valve spool shifts to direct control air into the winch motor to operate the winch in the desired direction.

Winch operation must correspond to the directions indicated by the arrows located on the pendant levers.

Depress pendant levers using smooth, even movements. To operate the winch using the pendant:

1. To operate in the haul-in direction, depress the ‘RIGHT’ lever.
2. To operate in the payout direction, depress the ‘LEFT’ lever.
3. To throttle operating speed regulate the amount the lever is depressed. Depress lever completely for maximum speed; depress lever partially for slower speeds.
4. To stop haul-in or payout operation release the lever. Lever will spring return to off and winch motor will stop.

NOTICE

• **Pendant haul-in and payout levers provide variable speed operation. For low speed operation push appropriate lever slightly; for full speed operation push appropriate lever fully.**

* To ensure accurate winch control when remotely operating the winch at distances greater than 60 feet (18 metres) contact **Ingersoll-Rand Technical Sales** for control suitability.

Pendant Operation

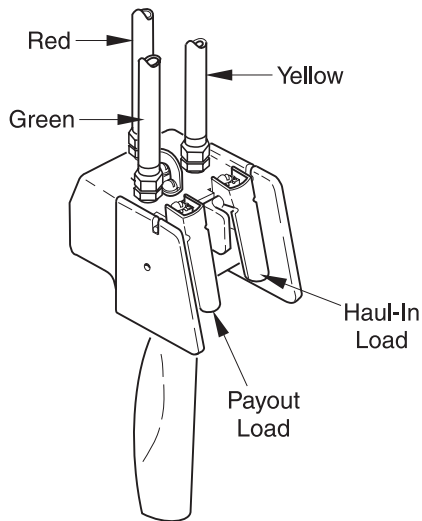

(Dwg. MHP1311)

Emergency Stop

Optional feature. Refer to Dwg. MHP0671 and MHP0754. The emergency stop device is located at the air inlet of the winch on local control models, and on the pendant on remote control models. When activated, winch drum rotation will immediately cease.

1. To start winch operation depress the 'ON' button.
2. To operate winch, depress the appropriate 'Haul-in' or 'Payout' lever.
3. In the event of an emergency all winch operation can be stopped by pushing the emergency stop button. This will prevent air from reaching the winch motor, engage the winch automatic brake(s) and stop winch haul-in or payout movement.
4. If depressed, the 'OFF' button will also stop winch operation.
5. To reset the Emergency Stop Valve:
 - a. Locate the serrated ring directly below the emergency stop button. Rotating the serrated ring clockwise, will cause the emergency stop button to 'pop up'.
 - b. Depress the emergency stop valve 'ON' button.

Winch Overload Device

Optional feature. The overload device is integrated into the winch air motor control air system and prevents the winch from lifting a load greater than the overload value provided in the "INSPECTION" section. If an overload is detected, inlet supply air is stopped and the winch will not operate.

If the overload device is activated the load must be lowered and reduced. Alternative methods should be used to accomplish the task. To lower the load reset the winch:

1. Locate the serrated ring directly below the emergency stop button. Rotating the serrated ring clockwise, causes the emergency stop button to 'pop up'.
2. Depress the emergency stop valve 'ON' button.
3. Operate the winch control in the payout direction.

Local Control Emergency Stop Valve Operation

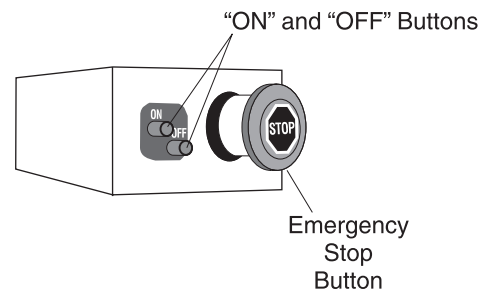

(Dwg. MHP0754)

Remote Pendant Emergency Stop Valve Operation

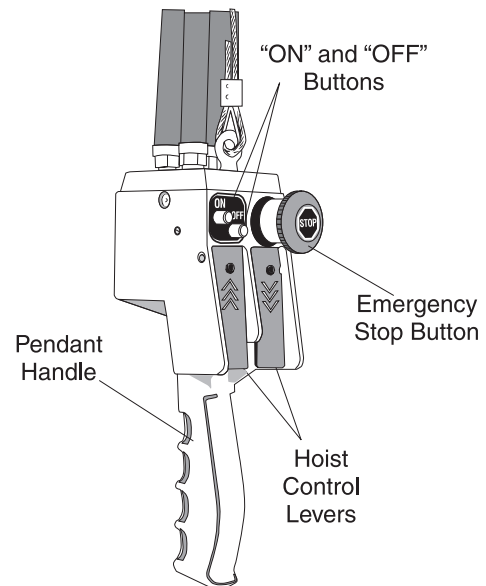

(Dwg. MHP0671)

Winch Brakes

Automatic Disc Brake

The automatic disc brake is a spring applied, air released brake. When the winch is operated in the payout direction air pressure acting on the diaphragm overcomes spring pressure and releases the brake. The brake automatically engages when winch operation is returned from the payout direction to neutral or when shifted to the haul-in direction. When the winch is in the neutral or haul-in positions the brake air is vented and the brake springs apply the brake. The springs, acting on the pressure plate, compress the brake friction and separator plates and engage the brake to prevent drum rotation in the payout direction.

The cam type sprag clutch assembly allows drum rotation in the haul-in direction with the brake plates engaged, but prevents the drum from rotating in the payout direction.

Disc brake adjustment is not required. If the disc brake does not operate properly it must be disassembled, inspected and repaired.



• If the brake is disassembled, the friction and separator plates must be correctly installed as shown in the "MAINTENANCE" section of this manual. Failure to correctly install the friction and separator plates can cause injury and/or property damage.

Manual Drum Brake

Optional feature. Refer to Dwg. MHP1375.

The manual drum brake may be applied by pushing down on the handle (135) and released by pulling up. By pushing the handle down fully it will go over-center and lock in that position, preventing drum rotation. The drum brake must be kept properly adjusted to hold the required load. Refer to 'Adjustments' in the "MAINTENANCE" section. If brake band cannot be adjusted to hold the rated load, the brake must be disassembled, inspected and repaired.

Drum Brake Handle Operation

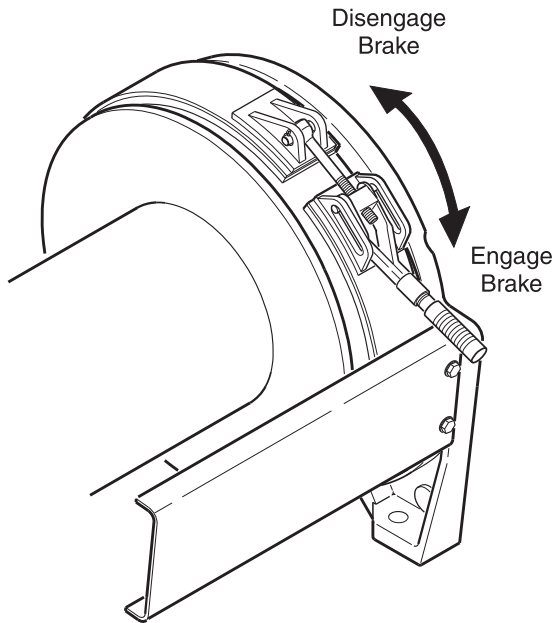

(Dwg. MHP1375)

Automatic Drum Brake

Optional feature. The automatic drum brake is a spring applied, air released, externally mounted brake which uses an air actuated, spring loaded cylinder to automatically disengage the brake when the motor is operated in either the haul-in or payout directions. Air pressure directed to the cylinder overcomes spring pressure to release the brake and allow the drum to rotate. When the control valve is placed in the neutral position, the air in the cylinder is vented which allows the cylinder spring to automatically engage the brake and prevent drum rotation. Adjustments to the cylinder clevis can be made to compensate for normal brake lining wear. The drum brake must be kept properly adjusted to hold the required load. Refer to 'Adjustments' in the "MAINTENANCE" section. If brake band cannot be adjusted to hold rated load, the brake must be disassembled, inspected and repaired.

Free Spool

Optional feature. Refer to Dwg. MHP1322.

The Free Spool option allows wire rope to be spooled from the drum without operating the winch motor. During normal winch operations the free spool is in the non-free spool position. The output shaft connects the outboard upright to the drum. The free spool handle is in the DOWN position.



• To avoid damage to the structure and winch the winch drum must be stationary and there must be no load on the wire rope during Free Spool operation.

Free Spool Position:

1. Engage the drum band brake to lock drum in position.
2. Pull handle (509) out.
3. Rotate the handle (509) counterclockwise, 180° to the 'up' position.
4. Release handle. Ensure handle is engaged in slots in detent plate (510).

The drum is now in free spool. During free spool operations use the drum band brake to control drum speed during wire rope payout.

Non Free Spool Position:

Before operating the winch with the motor, ensure winch is not in free spool mode.

1. Engage the drum band brake.
2. Pull handle (509) out.
3. Rotate handle clockwise, 180° to the 'down' position. This connects the winch drum to the outboard upright. If required, the band brake can be carefully released to allow drum to rotate to assist in lining up outboard gear (28) splines with drum and upright.
4. Release handle. Ensure handle is engaged in slot in detent plate (510).

Free Spool Operation Drawing

NOTICE

• Drawing view reversed. Handle is located on the opposite (right hand as viewed side of housing).

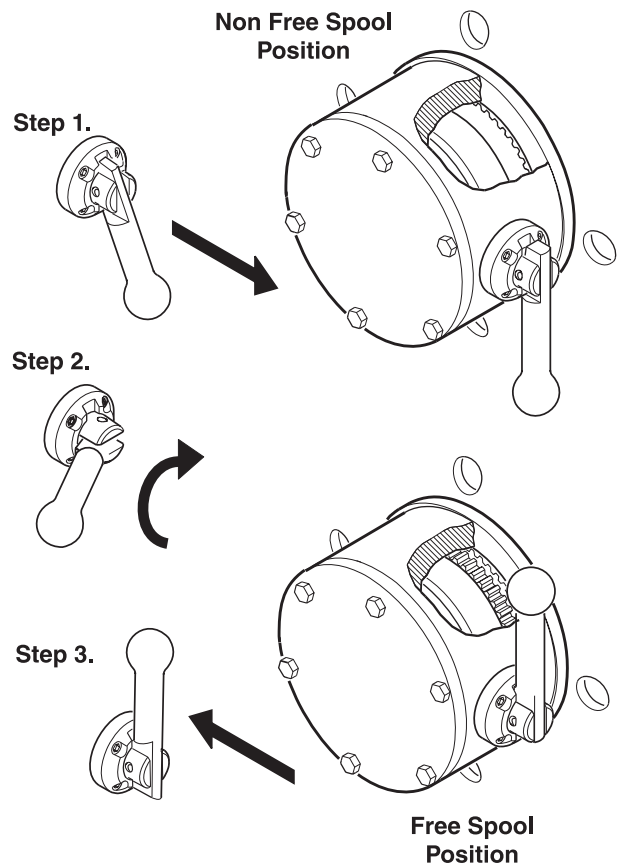

Reverse procedure before operating winch.

(Dwg. MHP1322)

Inspection information is based in part on American National Standards Institute Safety Codes (ASME B30.7).

⚠ WARNING

- **All new, altered or modified equipment should be inspected and tested by personnel instructed in safety, operation and maintenance of this equipment to ensure safe operation at rated specifications before placing equipment in service.**
- **Never use a winch that inspection indicates is damaged.**

Frequent and periodic inspections should be performed on equipment in regular service. Frequent inspections are visual examinations performed by operators or personnel trained in safety and operation of this equipment and include observations made during routine equipment operation. Periodic inspections are thorough inspections conducted by personnel trained in the safety, operation and maintenance of this equipment. ASME B30.7 states inspection intervals depend upon the nature of the critical components of the equipment and the severity of usage. The inspection intervals recommended in this manual are based on intermittent operation of the winch eight hours each day, five days per week, in an environment relatively free of dust, moisture, and corrosive fumes. If the winch is operated almost continuously or more than the eight hours each day, more frequent inspections will be required.

Careful inspection on a regular basis will reveal potentially dangerous conditions while still in the early stages, allowing corrective action to be taken before the condition becomes dangerous.

Deficiencies revealed through inspection, or noted during operation, must be reported to designated personnel instructed in safety, operation and maintenance of this equipment. A determination as to whether a condition constitutes a safety hazard must be decided, and the correction of noted safety hazards accomplished and documented by written report before placing the equipment in service.

Records and Reports

Inspection records, listing all points requiring periodic inspection should be maintained for all load bearing equipment. Written reports, based on severity of service, should be made on the condition of critical parts as a method of documenting **periodic** inspections. These reports should be dated, signed by the person who performed the inspection, and kept on file where they are readily available for authorized review.

🔧 Wire Rope Reports

Records should be maintained as part of a long-range wire rope inspection program. Records should include the condition of wire rope removed from service. Accurate records will establish a relationship between visual observations noted during frequent inspections and the actual condition of wire rope as determined by periodic inspections.

Frequent Inspection

On equipment in continuous service, frequent inspection should be made by operators at the beginning of each shift. In addition, visual inspections should be conducted during regular operation for indications of damage or evidence of malfunction (such as abnormal noises).

1. **WINCH.** Prior to operation, visually inspect winch housings, controls, brakes, sideframes, uprights and drum for indications of damage. Any discrepancies noted must be reviewed and inspected further by authorized personnel instructed in the operation, safety and maintenance of this winch.
2. **WIRE ROPE.** Visually inspect all wire rope which can be expected to be in use during the day's operations. Inspect for wear and damage indicated by distortion of wire rope such as kinking, "birdcaging," core protrusion, main strand displacement, corrosion, broken or cut strands. If damage is evident, do not operate winch until the discrepancies have been reviewed and inspected further by personnel knowledgeable on wire rope safety and maintenance procedures.

NOTICE

• **The full extent of wire rope wear cannot be determined by visual inspection. At any indication of wear inspect the wire rope in accordance with instructions in "Periodic Inspection."**

3. **AIR SYSTEM.** Visually inspect all connections, fittings, hoses and components for indication of air leaks. Repair any leaks or damage.
4. **BRAKES.** During winch operation test brakes. Brakes must hold load without slipping. Automatic brakes must release when winch motor throttle or pendant is operated. If brakes do not hold load, or do not release properly, the brakes must be adjusted or repaired.
5. **WIRE ROPE REEVING.** Check reeving and ensure wire rope is properly secured to the drum. Do not operate the winch unless the wire rope feeds onto the drum smoothly.
6. **LUBRICATION.** Refer to the "LUBRICATION" section for recommended procedures and lubricants.
7. **PENDANT (optional feature).** Ensure operation of pendant levers are smooth and that winch is responsive to pendant control. Pendant levers must spring return to neutral position when released.
8. **MANUAL THROTTLE LEVER.** Ensure operation of manual throttle lever is smooth and winch is responsive to lever movement. Lever must return to neutral when released. If winch responds slowly or control sticks, do not operate winch until all problems have been corrected.
9. **MOTOR.** During operation check motor housing for excess heat build up. Housing should not be hot to the touch. Listen for grinding or knocking noises in the motor. There should be no grinding or knocking noises. Ensure lubricated air supply provides a minimum of 3 drops of ISO VG 32 (10W) oil. Operate motor slowly in both directions to verify operation.

Periodic Inspection

Periodic inspection intervals for winch use under various conditions is listed below:

NORMAL yearly	HEAVY semiannually	SEVERE quarterly
-------------------------	------------------------------	----------------------------

Disassembly may be required as a result of frequent inspection findings or in order to properly inspect the individual components. Disassembly steps are described in the "MAINTENANCE" section. Maintain written records of periodic inspections to provide an accumulative basis for continuing evaluation. Inspect all items listed in 'Frequent Inspection.' Also inspect the following:

1. **FRAMES and UPRIGHTS.** Check for deformed, cracked or corroded main components. Replace damaged parts.
2. **FASTENERS.** Check retainer rings, split pins, capscrews, nuts and other fasteners on winch, including mounting bolts. Replace if missing or damaged and tighten if loose.
3. **DRUM and SHEAVES.** Check for cracks, wear or damage. Replace if necessary.
4. **WIRE ROPE.** In addition to "Frequent Inspection" requirements, also inspect for the following:
 - a. Build-up of dirt and corrosion. Clean with steam or a stiff wire brush to remove dirt and corrosion if necessary.
 - b. Loose or damaged end connection. Replace if loose or damaged.
 - c. Check wire rope anchor is secure in drum.
 - d. Verify wire rope diameter. Measure the diameter of the wire rope from crown-to-crown throughout the life of the wire rope. Recording of the actual diameter should only be done with the wire rope under equivalent loading and in the same operating section as accomplished during previous inspections. If the actual diameter of the wire rope has decreased more than 1/64 inch (0.4 mm) a thorough examination of the wire rope should be conducted by an experienced inspector to determine the suitability of the wire rope to remain in service. Refer to Dwg. MHP0056.

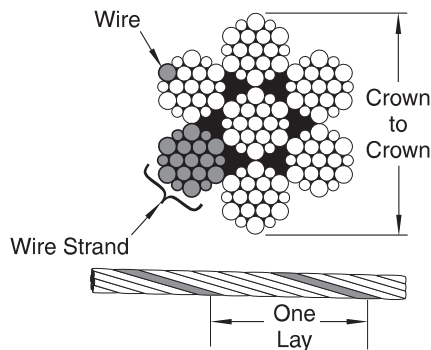

(Dwg. MHP0056)

5. **ALL COMPONENTS.** Inspect for wear, damage, distortion, deformation and cleanliness. If external evidence indicates damage, disassemble as required to conduct a detailed inspection. Inspect gears, shafts, bearings, sheaves, springs and covers. Replace worn or damaged parts. Clean, lubricate and reassemble.

6. **BRAKES.** Individually test brakes installed to ensure proper operation. Brakes must hold a **100% rated load** at mid drum without slipping. If indicated by poor operation or visual damage, disassemble and repair brake(s). Check all brake surfaces for wear, deformation or foreign deposits. Clean and replace components as necessary. Adjustments can be made to the drum band brake to compensate for normal brake lining wear. Refer to 'Adjustments' in the "MAINTENANCE" section. If brake band cannot be adjusted to hold rated load, replace the brake band assembly. Adjustments cannot be made to the disc brake. The disc brake must be repaired as described in the "MAINTENANCE" section.
7. **FOUNDATION or SUPPORTING STRUCTURE.** Check for distortion, wear and continued ability to support winch and rated load. Ensure winch is firmly mounted and that fasteners are in good condition and tight.
8. **LABELS AND TAGS.** Check for presence and legibility of labels. Replace if damaged or missing.
9. **DRUM GUARD (optional feature).** Verify fasteners are tight and in good condition. Ensure guard is in good condition.
10. **EMERGENCY STOP VALVE (optional feature).** During winch operation verify the emergency shut-off valve operation. Valve must stop winch operation quickly. Valve must reset properly. Refer to 'Emergency Shut-off Valve' in the "OPERATION" section for procedures.
11. **OVERLOAD DEVICE (optional feature).** Ensure overload device is properly set to stop the winch when loads exceed 150% (+/- 25%) of winch rated capacity. If winch does not shut down, contact your distributor or the factory for repair information.

Winches Not in Regular Use

1. Equipment which has been idle for a period of one month or more, but less than six months, shall be given an inspection conforming to the requirements of "Frequent Inspection" before being placed in service.
2. Equipment which has been idle for a period of over six months shall be given a complete inspection conforming with the requirements of "Periodic Inspection" before being placed in service.
3. Standby equipment shall be inspected at least semiannually in accordance with the requirements of "Frequent Inspection". In abnormal operating conditions equipment should be inspected at shorter intervals.

INSPECTION AND MAINTENANCE REPORT
Ingersoll-Rand Model FA2A Air Winch

Model Number:		Date:
Serial Number:		Inspected by:
Reason for Inspection: (Check Applicable Box)		
<input type="checkbox"/>	1. Scheduled Periodic Inspection: ___ Quarterly ___ Semiannually ___ Yearly	Operating Environment: Normal: ___ Heavy: ___ Severe: ___
<input type="checkbox"/>	2. Discrepancy(s) noted during Frequent Inspection	
<input type="checkbox"/>	3. Discrepancy(s) noted during maintenance	
<input type="checkbox"/>	4. Other: _____	

Refer to the Parts, Operation and Maintenance Manual "INSPECTION" section for general inspection criteria. Also, refer to appropriate National Standards and codes of practice. If in doubt about an existing condition contact the nearest Ingersoll-Rand distributor or the factory for technical assistance.

COMPONENT	CONDITION		CORRECTIVE ACTION		NOTES
	Pass	Fail	Repair	Replace	
Uprights and Sideframes					
Disc Brake (125% Load Test)					
Disc Brake (Visual Inspection)					
Drum Band Brake (125% Load Test)					
Drum Band Brake (Visual Inspection)					
Motor					
Controls					
Air System					
Fasteners					
Reduction Gears					
Labels and Tags			---		
Shafts					
Drum Guard					
Wire Rope Wedge			---		
Wire Rope			---		
Other Components (list in NOTES section)					

TESTING	Pass	Fail	NOTES
Operational (No Load)			
Operational (10% Load)			
Operational (Maximum Test Load *)			

* Maximum test load is 125% of rated line pull.
 This form may be copied and used as an inspection/maintenance record.

TROUBLESHOOTING

This section provides basic troubleshooting information. Determination of specific causes to problems are best identified by thorough inspections performed by personnel instructed in safety, operation and maintenance of this equipment. The chart below provides a brief guide to common winch symptoms, probable causes and remedies.

SYMPTOM	CAUSE	REMEDY
Winch will not operate.	No air supply to winch.	Check air supply line connections and hoses.
	Winch is overloaded.	Reduce load to within rated capacity.
	Emergency Shut-off Valve engaged.	Reset Emergency Shut-off valve.
	Shipping plugs may still be in place.	Remove shipping plugs in control valve.
	Drum brake not released.	Disengage manual drum brake or refer to "Automatic Drum Brake" below.
Load continues to move when winch is stopped.	Brake(s) slipping.	Check brake band adjustment and brake band lining wear. Disassemble and inspect disc brake.
	Winch motor controls sticking.	Check pendant/throttle levers return to normal (neutral) positions when released.
		Disassemble, inspect and repair the pilot air control valve. Verify spool adjustment.
Winch does not lift load.	Motor may be damaged.	Remove and disassemble motor. Examine all parts and replace any that are worn or damaged.
	Insufficient air supply.	Verify air supply pressure and volume at winch inlet meets the requirements listed in the "SPECIFICATIONS" section. Clean air line filter.
Throttle or pendant lever moves but winch does not operate.	Motor may be damaged.	Disassemble and clean the motor and replace any worn or damaged parts.
	Insufficient air supply.	Ensure the air pressure at the winch inlet is at least 90 psig (6.3 bar/630 kPa) at rated volume. Clean air line filter.
	Emergency Stop Valve engaged.	Reset Emergency Stop valve.
	Overload Device engaged.	Reduce load to within rated capacity of winch and reset Emergency Stop Valve.
	Air leak.	Check hose connections. Check hose lines for wear or damage. Replace worn or damaged hoses.
Motor runs hot or makes excessive noise during operation.	Improper lubrication.	Set lubricator to provide a minimum of 3 drops per minute.
	Damaged or broken motor internal parts.	Disassemble and repair motor.
Winch runs slow.	Improper hose or fitting sizes.	Check fittings, connections and hoses for correct size and length. Replace parts that may cause restricted air flow. Inspect air line filter.
	Motor may be damaged.	Remove and disassemble motor. Inspect all parts and replace all worn or damaged parts.
	Brake(s) may not be releasing.	Refer to brake sections below.
Air lines freeze.	Water in air supply.	Install or drain air system moisture traps, moisture collecting air receivers and compressor aftercoolers. After corrective action has been taken, disconnect lines at winch inlet and purge with clean, dry air or nitrogen.

Automatic Drum Brake:

Brake will not release.	Damaged or leaking cylinder seals.	If air is noticed escaping from around the cylinder cover when attempting to release the brake disassemble and inspect brake. Replace all seals and repair or replace worn or damaged parts.
	Dirty filter in air supply.	Clean or replace filter.
Brake does not set when applied.	Hole in exhaust valve restricted or exhaust valve damaged.	Remove and inspect exhaust valve. Clean hole or replace damaged exhaust valve.

Automatic Disc Brake:

Brake fails to release.	Low air supply pressure.	Ensure supply air pressure at the brake inlet is at least 50 psig (3.4 bar/340 kPa).
	Leaking diaphragm.	Disassemble brake and replace diaphragm.
	No release pressure at the brake port.	Verify proper operation of winch controls.

LUBRICATION

To ensure continued satisfactory operation of the winch, all points requiring lubrication must be serviced with the correct lubricant at the proper time interval as indicated for each assembly.

The FA2A air motor is designed without an oil sump. The only lubrication necessary for operation is that provided by a lubricated air supply.

Any excess lubricant or moisture in the motor housing will be discharged through the exhaust.

The lubrication intervals recommended in this manual are based on intermittent operation of the winch eight hours each day, five days per week. If the winch is operated almost continuously or more than the eight hours each day, more frequent lubrication will be required. Also, the lubricant types and change intervals are based on operation in an environment relatively free of dust, moisture, and corrosive fumes. Use only those lubricants recommended. Other lubricants may affect the performance of the winch. Approval for the use of other lubricants must be obtained from your **Ingersoll-Rand** distributor. Failure to observe this precaution may result in damage to the winch and/or its associated components.

INTERVAL	LUBRICATION CHECKS
Start of each shift	Check flow and level of air line lubricator (adjust flow to approximately 3 drops per minute at maximum motor speed.).
Monthly	Inspect and clean or replace air line filter.
	Check reduction gear oil level.
Yearly	Drain and refill winch reduction gear oil.

Note: Intervals are based on winch operation in a normal environment as described in the "INSPECTION" section. In 'Heavy' or 'Severe' operating conditions adjust lubrication intervals accordingly.

General Lubrication

1. Drain and replace oil in the disc brake and reduction gear after the first 50 hours of initial winch operation. Thereafter, drain and replace oil according to the intervals recommended.
2. Always inspect removed oil for evidence of internal damage or contamination (metal shavings, dirt, water, etc.). If indications of damage are noted, investigate and correct before returning winch to service.
3. After winch operation, allow oil to settle before topping off.
4. Always collect lubricants in suitable containers and dispose of in an environmentally safe manner.

Reduction Gear and Disc Brake Lubrication

Refer to Dwg. MHP0501.

The reduction gear and disc brake are filled with oil, from the factory. Check oil level before initial winch operation. These components are splash lubricated by the oil in the housing and have no other means of lubrication. It is therefore important to use high quality, Extreme Pressure (EP) rust and oxidation inhibited gear oils to ensure maximum performance and minimum down time for repairs. Oil capacity is approximately 2 quarts (1.9 litres).

Oil from the reduction gear assembly also provides lubrication for the disc brake.

The reduction gear is vented through the disc brake breather plug.

Reduction Gear and Disc Brake Recommended Lubricant

Temperature	Recommended Viscosity
Below 32° F (0° C)	ISO VG 68 (20W)
32° to 80° F (0° to 27° C)	ISO VG 100 (30W) *
Above 80° F (27° C)	ISO VG 150 (40W)

* Units are shipped from factory with ISO VG 100 (30W) lubricant. Reduction Gear capacity is approximately 2 quarts (1.9 litres).

Initial Reduction Gear Assembly Oil Change

It is recommend that the first oil change be done after approximately 50 hours initial operation. Always inspect removed oil for evidence of internal damage (metal shavings, dirt, water, etc.).

Lever Control Valve Lubrication

Refer to Dwg. MHP1314.

When changing the reduction gear oil, lubricate the lever control valve at fitting (313). Use one stroke of recommended grease to lubricate.

Recommended Grease

Temperature	Type Grease
-20° to 50° F (-30° to 10° C)	EP 1 multipurpose lithium based grease
30° to 120° F (-1° to 49° C)	EP 2 multipurpose lithium based grease

Winch Oil Fill and Drain Plug Location Drawing

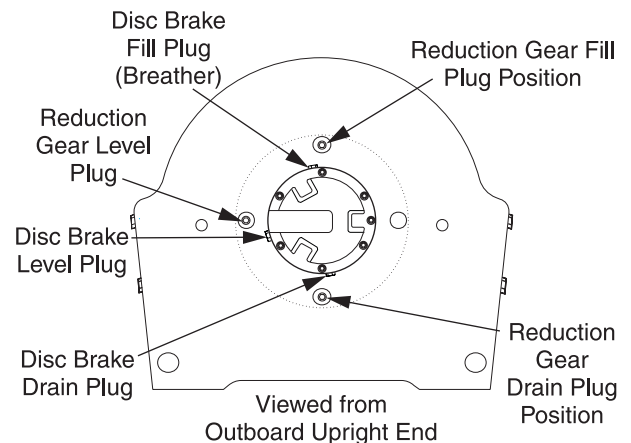

(Dwg. MHP0501)

Reduction Gear and Disc Brake Fill/Drain Procedures

Refer to Dwg. MHP0501.

NOTICE

• **There are only 2 plugged holes, located 90° apart, on reduction gear cover (33). To fill or drain reduction gear oil, the winch drum must be rotated to align the plugs for either the fill or drain operation.**

To Fill:

1. Rotate the winch drum to align the reduction gear plugs to the fill position. Fill plug position is at top center.
2. Remove the fill and drain plugs located on the reduction gear cover (33).
3. **Winch with disc brake:** do not remove the level plug located on the reduction gear cover. Instead, remove the level plug located on the disc brake housing.

NOTICE

• **Depending on ambient temperature it may take several minutes for oil to flow from the disc brake level plug hole. Wait 10 minutes after oil starts to flow from level plug hole before re-installing plug fittings.**

4. Fill slowly until oil flows from the disc brake level plug hole.
5. Re-install the plugs.

CAUTION

• **Do not over fill. Excess oil will reduce operating efficiency and increase oil temperature.**
• **The use of unsuitable oil may result in excessive temperature rise, loss of efficiency and possible damage to the gears. Use only high quality rust and oxidation inhibiting lubricant.**

To Drain:

1. Rotate the winch drum to align the reduction gear plugs to the drain position. Drain plug is located at bottom center.
2. Remove the reduction gear drain plug and install long pipe nipple threaded at one end to 3/8-18 NPT. Remove drain vent plug. Remove the disc brake drain plug.

NOTICE

• **Always drain oil into a suitable container and inspect drained oil for evidence of damage, metal shavings, dirt, water, etc. Dispose of oil in an environmentally safe manner.**

3. Collect the drained oil and dispose of properly. If replacing oil, refer to 'To Fill' instructions. Re-install the reduction gear and disc brake plugs.

Motor Assembly

Lubrication for the motor is provided by the air line lubricator. An air line lubricator must be installed in the air supply line as close as possible to the motor inlet, but no more than 10 feet (3 metres) away. The lubricator must provide a minimum of 3 drops per minute of ISO VG 32 (10W) oil.

Wire Rope

Follow the wire rope manufacturer's instructions. At a minimum, observe the following guidelines.

1. Clean with a brush or steam to remove dirt, rock dust or other foreign material on the surface of the wire rope.

CAUTION

• **Do not use an acid-based solvent. Only use cleaning fluids specified by the wire rope manufacturer.**

2. Apply a wire rope lubricant, **Ingersoll-Rand LUBRI-LINK-GREEN** or ISO VG 100 (30W) lubricant.
3. Brush, drip or spray lubricant weekly, or more frequently, depending on severity of service.

Seals and Bearings

If winch is disassembled, clean all parts thoroughly and coat bearings and seals with clean grease. Refer to the 'Recommended Lubricants' section. Use sufficient grease to provide a good protective coat.

⚠ WARNING

- Never perform maintenance on the winch while it is supporting a load.
- Before performing maintenance, tag controls:
DANGER - DO NOT OPERATE - EQUIPMENT BEING REPAIRED.
- Only allow personnel trained in safety and service on this winch to perform maintenance.
- After performing any maintenance on the winch, test winch to 125% of its rated line pull at mid drum before returning to service. (Testing to more than 125% of rated line pull may be required to comply with standards and regulations set forth in areas outside the USA.)
- Turn off air system and depressurize air lines before performing any maintenance.

INTERVAL	MAINTENANCE CHECK
Start of each shift (Operator or Maintenance Personnel)	Make a thorough visual inspection of the winch for damage. Do not operate the winch if damaged.
	Operate the winch at low RPM in both directions. Winch must operate smoothly without sticking, binding or abnormal noises. Check the operation of the brake(s).
3 Months (Maintenance Personnel)	Inspect the drum brake friction linings. Clean or replace parts as required. Adjust drum brake as necessary.
Yearly (Maintenance Personnel)	Inspect the winch gearing, shafts and bearings for wear and damage. Repair or replace as necessary.
	Check all the supporting members, including the foundation, fasteners, nuts, sheaves and rigging, etc. for indications of damage or wear. Repair or replace as required.

Thermoplastic Coating

Thermoplastic coating is an extremely tough and durable coating designed to take the toughest treatment without chipping or peeling. Special steps must be taken to protect the coating when parts are removed, replaced and if excessive environmental or operational conditions have damaged the coating.

🔧 Cleaning Parts

The area to be coated must be clean and free from loose coating. Remove any surface corrosion. To paint thermoplastic coated parts, the parts must be sand blasted in order to 'rough up' the surface for proper paint adhesion. Sand blasting will not remove thermoplastic coating (abrasive material will bounce off). Loose coating can be removed by cutting with a sharp cutting tool (chisel, putty knife or knife).

🔥 Heat Source

⚠ WARNING

- When using an open flame be aware of the materials around the work area. Some solvents, lubricants and materials are extremely flammable.
- Drain all components of lubricants, water or any other fluids. Remove, or open all vents and drains. Components will be hot and may discharge hot fluids or gases. Allow sufficient time for components to cool, or cool off components, prior to handling. Gaskets, 'O' rings, and any components that may be damaged should be removed prior to applying coating.

Thermoplastic coating is heat applied. The surface of the component to which the thermoplastic coating is being applied must be maintained at a temperature of a least 230° F (110° C), but not over 450° F (232° C). Optimum temperature is 300° F (149° C) for best results. A small propane torch (**Ingersoll-Rand** Part No. 71308886) or heat gun (**Ingersoll-Rand** Part No. 71308894) can be used.

NOTICE

- When using a heat source always keep it moving. Small circles work best. Failure to do so will result in a scorched area at the repair.

The choice of heat gun or propane torch depends on the size of the area to be coated and the amount of time available to accomplish the task. The propane torch heats the surface faster, but is hard to control and can scorch the coating. The heat gun is slower, easier to control and generally results in a better looking finish.

🔧 Repairing Surfaces

For minor repairs to the thermoplastic coating conduct the following:

1. If the under laying surface is not corroded and the scratch is less than 1/16 inch (1.6 mm) wide the surrounding thermoplastic coating can be heated until the material flows together. For clean surfaces with damage greater than 1/16 inch (1.6 mm) heat the area and then apply thermoplastic coating powder (**Ingersoll-Rand** Part No. 71308902 [2 oz. (56.7 g)]) to fill the area. Continue heating until coating liquefies and flows together with the existing coating.
2. Corrosion in damaged area must be removed. Sandblast or wire brush the area to remove corrosion. If corrosion exists, ensure the corrosion has not penetrated below the surface of existing thermoplastic coating. This can usually be easily determined by checking to see if the coating is loose around the corroded area. Cut away coating as necessary to expose corrosion for removal. If the damaged area is less than 1/16 inch (1.6 mm) wide the surrounding thermoplastic coating can be heated until the material flows together. For surfaces with damage greater than 1/16 inch (1.6 mm) heat the area and then apply thermoplastic coating powder (**Ingersoll-Rand** Part No. 71308902 [2 oz. (56.7 g)]) to fill the area. Continue heating until coating liquefies and flows together with the existing coating.

3. Allow the repaired area to cool. Quenching with water is acceptable. Inspect the repair. Rough spots, minor scorching and excess coating deposits can be wet sanded to remove the imperfections. To return the gloss finish, reheat the surface carefully.

For large bare surfaces or new parts:

Coating these components can be done more economically and with better end results by using an electrostatic powder application process or flamespray process. Contact **Ingersoll-Rand** Technical Assistance for more information.

For specific disassembly and assembly information refer to 'Assembly' or 'Disassembly' in the "MAINTENANCE" section.

Adjustments

Disc Brake

Brake adjustment is **not** required. If the disc brake does not hold 100% of rated load at mid drum, disassemble and repair.

NOTICE

• **Winches are provided with a breather plug located at the top of the disc brake housing. If the brake assembly is removed or repaired ensure the breather is installed and located at the top of the brake housing during reassembly.**

Manual Drum Band Brake

Optional feature. Refer to Dwg. MHP1372.

1. Release wire rope tension on the drum.
2. Raise handle (135) to free brake bands (136 and 137).
3. Remove cotter pin (139) and pin (138).
4. Rotate brake link stud (141) clockwise to increase brake torque.
5. Install pin (138) and check adjustment.

NOTICE

• **If brake band cannot be adjusted to hold the rated load, replace the brake band assembly.**

6. Adjust brake so when brake handle locks (goes over-center), brake will hold rated load.
7. Install cotter pin (139) when adjustment is complete.
8. Lift up the brake handle to free position.
9. Loosen capscrew (101) and rotate cam stop until both ends of the brake band are an equal distance from the drum brake band surface.
10. Tighten capscrew (101).

Automatic Drum Band Brake

Optional feature. Refer to Dwg. MHP1281.

For adjustments, references to "clockwise" and "counterclockwise" directions, in the text, refer to directions as viewed from the head end of capscrew (120).

NOTICE

• **If brake band cannot be adjusted to hold rated load, replace the brake band assembly.**

1. Loosen jam nut (117) closest to plunger (114).

2. Adjust band assembly using capscrew (120).
 - a. To loosen band brake, turn capscrew (120) in the counterclockwise direction.
 - b. To tighten band brake, turn capscrew (120) in the clockwise direction.

NOTICE

• **If the capscrew (120) is not accessible, the jam nut (117) [located closest to the head of capscrew (120)] may be used to adjust the band brake. Ensure capscrew turns with nut.**

3. When adjustments are complete tighten jam nut (117) closest to plunger (114).

Remote Pendant Control Valve Adjustment

Optional feature. Refer to Dwg. MHP1305.

If winch operating speeds differ from performance specifications the pilot air control valve may require adjustment.

1. Loosen nut (271) and adjust adjusting screw (270), located in the valve end cap (268). Screw in to slow payout speed; screw out to increase payout speed.

NOTICE

• **Turning adjusting screw (270) clockwise (in) decreases payout speed. Counterclockwise (out) increased payout speed. It is suggested that a chalk mark be placed on the drum flange so that drum rpm can be accurately counted.**

2. Adjust until drum speed for no-load haul-in equals the drum speed for full load payout.

Disassembly

General Disassembly Instructions

The following instructions provide the necessary information to disassemble, inspect, repair, and assemble the winch. Parts drawings are provided in the Parts Section.

If a winch is being completely disassembled for any reason, follow the order of the topics as they are presented.

It is recommended that all maintenance work on the winch be performed in a clean dust free work area.

In the process of disassembling the winch, observe the following:

1. Never disassemble the winch any further than is necessary to accomplish the needed repair. A good part can be damaged during the course of disassembly.
2. Never use excessive force when removing parts. Tapping gently around the perimeter of a cover or housing with a soft hammer, for example, is sufficient to break the seal.
3. Do not heat a part with a flame to free it for removal, unless the part being heated is already worn or damaged beyond repair and no additional damage will occur to other parts.

In general, the winch is designed to permit easy disassembly and assembly. The use of heat or excessive force should not be required.

4. Keep the work area as clean as practical, to prevent dirt and other foreign matter from getting into bearings or other moving parts.

5. All seals, gaskets and 'O' rings should be discarded once they have been removed. New seals, gaskets and 'O' rings should be used when assembling the winch.
6. When grasping a part in a vise, always use leather-covered or copper-covered vise jaws to protect the surface of the part and help prevent distortion. This is particularly true of threaded members, machined surfaces and housings.
7. Do not remove any part which is a press fit in or on a subassembly unless the removal of that part is necessary for repairs or replacement.
8. When removing ball bearings from shafts, it is best to use a bearing puller. When removing bearings from housings, drive out the bearing with a sleeve slightly smaller than the outside diameter of the bearing. The end of the sleeve or pipe which contacts the bearing must be square. Protect bearings from dirt by keeping them wrapped in clean cloths.

Thermoplastic Coated Parts Disassembly

Thermoplastic coating on capscrew heads, nuts, housings and other components can be removed as follows:

CAUTION

• **Separate parts using proper tools. Ensure machined surfaces are not damaged during disassembly.**

1. Fasteners:
 - a. Push tool into or over fastener, forcing coating off of the fastener.
 - b. If coating is too thick, then heat the fastener to soften coating. Socket or wrench will push softened coating off, allowing removal of part.
 - c. For socket head capscrews, setscrews, etc., heat the component until coating is softened. Use a small screwdriver or similar tool to remove coating to allow access for wrench.
2. For housings, plates and other coated mating components use a sharp knife or similar tool to cut through coating around mating area of components.

Drum Guard Disassembly

Optional feature. Refer to Dwg. MHP0658.

1. Remove capscrews (592).
2. Remove brackets (591) by sliding out of drum guard (590).
3. Remove drum guard (590) from rear (drum brake side) sideframe (64) carefully. By design the drum guard attaches to the sideframe using tabs. The smaller, upper tabs are visible on the top of the sideframe. The longer, lower tab is located beneath the sideframe edge. During removal care must be taken not to bend the tabs. To correctly remove, at the point where the drum guard and the sideframe meet, push, or tap the lower portion of the drum guard in towards the winch drum (62). The direction of force should be directly away from the sideframe. Do not pull 'up' or 'down' as the tabs may become deformed.

Winch Disassembly

Refer to Dwg. MHP0947, MHP1248, MHP1310 and MHP1324.

1. Remove the wire rope from the drum. Remove wire rope anchor (63) and store for reassembly.
2. Relieve pressure in the air lines and winch air components by operating the winch control several times after the air supply has been turned off.

WARNING

• **Shut off, bleed down and disconnect the air supply line before performing any disassembly procedures.**

3. Disconnect and tag the air lines.
4. To drain oil refer to "LUBRICATION" section.
5. Remove the fasteners securing winch to its foundation and move the winch to a suitable work area before beginning disassembly.

WARNING

• **The air motor weighs approximately 100 lbs. (45.3 kg). Adequately support the air motor before removing the motor mounting capscrews.**

6. Remove the four capscrews (221) securing the motor assembly to the motor adapter (71). Using a hoist to support the motor, pull the motor straight away from the winch. Refer to the 'Motor Disassembly' section if motor disassembly is required.
7. Remove drive shaft (61) and coupling (60).
8. If equipped, disconnect the drum band brake.

Manual Drum Brake:

Refer to Dwg. MHP1372.

- a. Remove cotter pin (139) and pin (138).
- b. Loosen capscrew (133) and allow cam stop (132) to rotate freely.
- c. To disassemble further, refer to 'Manual Band Brake Disassembly' and Dwg. MHP1372.

Automatic Drum Brake:

Refer to Dwg. MHP1374.

- a. Remove capscrews (101), spacers (102) and (103).
- b. Remove and save spacer (105).
- c. Loosen two nuts (117).
- d. Remove capscrew (120), pivot bar (119) and nuts (117).
- e. To disassemble further, refer to 'Automatic Band Brake Disassembly' and Dwg. MHP1374.
9. Remove any other externally mounted winch attachments. Refer to the applicable section for disassembly instructions.

CAUTION

• **There are a total of eight capscrews securing the brake cover to the brake housing. Two of these capscrews hold the brake assembly together, but do not attach to the outboard upright. One capscrew attaching the brake assembly is located directly beneath the brake air line fitting connection; the other is located 180 degrees from the air fitting. The heads of these two capscrews sit deeper into the counterbores of the brake cover. Do not remove these two capscrews until the brake has been separated as an assembly from the winch and the directions in the 'Disc Brake Disassembly' section have been reviewed.**

10. Disconnect and remove brake hose (75). Remove six capscrews (1) attaching disc brake assembly to outboard upright (26). Remove disc brake assembly by tapping around housing with a soft hammer or mallet while pulling out and away from upright in a horizontal direction. Remove dowel pin (20) and store until re-installation. To further disassemble the disc brake assembly, refer to Dwg. MHP0947 and the 'Disc Brake Disassembly' section.

11. **On standard winch:** using a hoist to support the drum, remove sideframes (64) and (65), one at a time, by removing four capscrews (66) attaching each sideframe to uprights (26) and (68).
12. **On Open Frame (Face) winch:** To assist reassembly, record the number and location of washers (584) installed between the sideframes (571) and (573) and bars (570). Using a hoist to support the drum, remove rear sideframe (64) by removing four capscrews (66) attaching sideframe to uprights (26) and (68). Remove front bars (570) and sideframes (571) and (573) as an assembly by removing four capscrews (574) and washers (584). To separate bars from sideframes, remove capscrews (572). Refer to Dwg. MHP1324.
13. Remove the inboard (motor end) upright (68) by pulling straight away from drum (62) in a horizontal direction. Remove oil seal (29) and bearing (30) from upright. Discard oil seal. Discard bearing if inspection indicates replacement.
14. If equipped, remove the drum band brake assembly (104) by sliding over the end of the drum (62) flange. To further disassemble the drum brake, refer to the appropriate 'Manual Drum Band Brake Disassembly' or 'Automatic Drum Band Brake Disassembly' section.
15. Remove the outboard (disc brake end) upright (26) by pulling straight away from drum (62) in a horizontal direction. Remove oil seal (29) and bearing (30) from upright. Discard oil seal. Discard bearing if inspection indicates replacement.

CAUTION

• **Ensure the reduction gear oil is drained before disassembly and that the drain and fill plugs are removed. When using jacking bolts, ensure the cover lifts evenly by turning bolt one full turn and then repeating on the other bolt. If cover jams, remove jacking bolts and gently tap around the cover to reseal it before starting over. Careful prying of the cover along its diameter during jacking, using a soft material wedge, to guide the cover is acceptable. Care must be taken not to scar, gouge or damage the machined finishes on the cover and the reducer housing mating surfaces during parts separation.**

16. Stand drum on end with reduction gear on top. Remove reduction gear assembly from drum (62) by removing six capscrews (32) attaching end cover (33) to drum. Screw two 7/16 - 20 UNF x 1-1/2 inch capscrews into the threaded holes in cover (33). Turn both screws evenly until cover is separated from housing. Remove cover.
17. Screw two 1/2 - 13 UNC x 1-1/2 inch capscrews into the threaded holes in the reducer housing (59). Turn both screws evenly until housing is separated from drum. Attach suitable lifting eyes to the capscrews and remove housing from drum.
18. To further disassemble reduction gear refer to 'Reduction Gear Disassembly' section.

Control Valve and Inlet Manifold Removal

Refer to Dwg. MHP1314.

1. Disconnect main air supply line at the winch.
2. Disconnect disc brake air line from the elbow (319) fitting located on the control valve.
3. Remove capscrews (331) and lift off control valve assembly (260) and gasket (321).

4. Remove capscrews (614) and lift manifold cover (607) and manifold (606) from motor housing (220). Manifold and cover are bonded together and should not be separated unless repairs are required to one of the parts.
5. Remove and discard gasket (611).

Control Valve Disassembly

Refer to Dwg. MHP1314.

NOTICE

• **Match mark control valve parts to ensure proper reassembly.**

1. Remove the two capscrews (302) and lockwashers (304) that hold the valve body retainer (305).
2. Mark the square end on the valve body (316) and the handle (300) to ensure correct orientation during re-assembly.
3. Drive out pin (301) and remove handle (300).
4. Note how spring (303) is positioned before removing it. Pull valve body (316) out of the valve bushing (314) while disconnecting the spring (303).
5. Remove seal rings (315) from valve body (316).
6. Check parts for score marks or wear.
7. Measure clearance between the valve bushing (314) and valve body (316). Clearance between valve bushing and valve body should not exceed 0.002 inch (0.05 mm) or excessive air leakage will occur.
8. Remove the two capscrews (302) and lockwashers (304) attaching flange (318) to valve body.
9. Remove flange and gasket (317). Discard gasket.

Remote Control Valve and Inlet Manifold Removal

Optional feature. Refer to Dwg. MHP1304.

1. Disconnect main air supply line at the winch.
2. Disconnect disc brake air line from connector fitting (621) located on valve assembly (355).
3. Disconnect pendant hoses from valve assembly.
4. Remove capscrews (608) and lift off valve (355) and cover (607) assembly.
5. Remove capscrews (615) and separate cover (607) from valve assembly (355).
6. Remove capscrews (614) and lift manifold (606) from motor housing (220).
7. Remove gasket (611).

Emergency Stop Disassembly

Optional feature. Refer to Dwg. MHP1331.

NOTICE

• **During disassembly, take care to keep the work area free from dirt and contamination. It is recommended that parts be moved to a clean, suitable work area.**

1. Disconnect fittings (513) from connectors (534) at the manifold (606).
2. Note orientation of muffler to shut off valve (522) for assembly. Separate muffler (525), nipple (524) and elbow (523) from shut off valve.
3. Separate union (536).
4. Support shut off valve and remove capscrews (526) and spacers (532). Remove assembly.

- Note hose route and fitting orientation for reassembly, then disconnect fittings (513) from emergency stop valve (541).
- Remove capscrews (542). Remove emergency stop valve as an assembly and store in a clean location until reassembly.
- Remove capscrews (538) and bracket (539) from shut off valve (522).
- Note hose route and fitting orientation for reassembly, then disconnect fittings (513), (519) and (622) from shuttle valve (517).
- Separate shuttle valve (517) from shut off valve (522) at elbow (537) by rotating shuttle valve counterclockwise. Remove elbow (537).
- Note fitting orientation for reassembly, then disconnect fittings (513) and (622) from Delta 'P' valve (533). Remove fittings (514), (515) and (519).
- Separate bracket (529) by removing capscrews (531). Remove bracket (527) by removing capscrews (528).

Remote Emergency Stop Disassembly

Optional feature. Refer to Dwg. MHP1323.

NOTICE

• **During disassembly, take care to keep the work area free from dirt and contamination. It is recommended that parts be moved to a clean, suitable work area.**

- Disconnect main air supply line at the winch.
- Disconnect disc brake air line from connector fitting (621) located on valve assembly (355).
- Disconnect pendant hoses from valve assembly.
- Remove capscrews (608) and lift valve (355) and cover (607) assembly.
- Remove capscrews (615) and separate cover (607) from valve assembly (355).
- Remove capscrews (614) and lift manifold (606) from motor housing (220).
- Remove gasket (611).
- Note orientation of muffler to shut off valve for reference during assembly. Remove muffler (525), nipple (524) and elbow (523) from shut off valve (522).
- Note fitting orientation for reassembly, then disconnect hoses and fittings from shut off valve (522), shuttle valve (517) and Delta 'P' valve (533).
- Separate shuttle valve (517) from shut off valve (522) at elbow (537) by rotating shuttle valve counterclockwise (left, circular direction). Remove elbow (537).
- Separate shut off valve (522) at nipple fitting (578) by rotating shut off valve counterclockwise (left, circular direction). Remove fitting (535).

Motor Disassembly

Refer to Dwg. MHP1310.

NOTICE

• **Internal components of the motor are machined to very close tolerances. Ensure that work area and parts are kept very clean to prevent damage or contamination to components.**

- Disconnect air line to winch.
- Remove muffler (234) as an assembly.

WARNING

• **The air motor weighs approximately 100 lbs. (45.3 kg). Adequately support the air motor before removing the motor mounting capscrews.**

- Use a nylon sling and suitable hoist to support the motor assembly.
- Remove capscrews (221) and pull motor straight away from motor adapter (71).
- Place motor on a suitable clean bench with air inlet facing up.
- Refer to 'Control Valve Disassembly' for manifold removal.
- Remove capscrews (224) and pull exhaust manifold (233) off of motor housing.
- Tip motor onto the open end. Remove capscrews (224) and separate cover (223) from motor housing (220).
- Remove setscrew (218) and loosen capscrew (216) and locknut (217). Pull counterweight (214) off of crankshaft pin (213).
- Remove capscrews (229) from cover assemblies (226) and (227) and remove cylinder assemblies.
- Rotate crankshaft slowly until the flat portion of the piston assembly (240) can be lifted into the square portion of the cylinder port in the motor housing. Lift the piston assembly off the crankshaft pin (213) and slide back out through the motor housing.
- Repeat this operation for the other piston assembly.
- Push spool (231) out of motor housing (220). Remove and discard 'O' rings (230).

CAUTION

• **Use a press to remove the following components. DO NOT use a hammer to remove parts as this can cause damage to the link rod and piston rod.**

Piston Disassembly

- Remove piston sleeve (243) and 'O' ring (242) from the piston and discard.
- Press out pin (246) and remove washers (248).
- Pull link rod (244) apart from piston rod (241).
- Press out bearings (245) and (247).

Crankshaft Disassembly

- Bend the locking tab on tab washer (203) out of the slot in locknut (202).
- Use a wooden (or fiberglass) tool handle to lock the crankshaft. Place it through two of the cylinder ports in the motor housing and let the crankshaft pin come to rest on it.
- Remove locknut (202) and tab washer (203).
- Press the crankshaft assembly (only, NOT bearing (204)) out through the main cavity of the motor housing.
- Pull bearing (204) and attached retainer ring back out, towards adapter side of motor housing.

Disc Brake Disassembly

Refer to Dwg. MHP0947.

NOTICE

• **Prior to disassembly, matchmark the cover (2), housing (6) and support plate (19) to assist in proper alignment of parts during reassembly.**

1. Remove brake shaft (25) and retainer ring (23). Place brake assembly on a flat surface with cover (2) on top. Remove elbow fitting (80) and exhaust valve (79). Alternately and evenly loosen the two capscrews (1) until the brake spring (17) compression has been relaxed. Remove capscrews.
2. Remove cover (2) and diaphragm (3).
3. Using a small tipped screwdriver or similar tool, remove ring (4). Remove diaphragm support (5).
4. Remove housing (6) by lifting straight away from brake parts. Collect the three dowel pins (9) and store until reinstallation. Inspect pins for deformation, wear and damage. Replace if parts fail inspection.
5. Alternately remove the six separator plates (14) and five friction plates (13).
6. Remove the pressure plate (15) and springs (17).
7. Grasp the outer race (12) and remove the sprag clutch as an assembly. Remove the spacer (11) between the sprag clutch assembly and support plate (19).
8. Remove gasket (18) from support plate (19). Discard gasket.
9. To remove the bearing (21) from the support plate (19) first remove the retainer ring (22) and then press the bearing out of the support plate recess.

NOTICE

• **To prevent accidental damage, remove the bearing (21) only if it requires replacement.**

10. Separate the sprag clutch assembly into its component parts. The sprag clutch assembly consists of the inner race (10), two spacers (11), the outer race (12) and the sprag clutch (16). The sprag clutch can be further disassembled into two wearing plates and the sprag cage.

Automatic Drum Band Brake Disassembly

Optional feature. Refer to Dwg. MHP1281.

1. Loosen jam nut (117) closest to plunger (114). Turn capscrew (120) counterclockwise until disconnected from plunger.
2. Disconnect air line from brake cylinder (121). With the aid of a strap wrench, remove brake cylinder (121) and components as an assembly by turning brake cylinder counterclockwise until disconnected from brake bracket (106).
3. Disconnect brake bracket (106) from band assembly by removing three capscrews (101), spacers (102) and spacer tubes (103). Remove spacer plate (105).
4. Disconnect brake bracket from motor end upright (68) by removing two capscrews (107) and two capscrews (112).

DANGER

• **Springs (124) and (127) exert a considerable force on cover (125). Extreme care must be taken when disassembling the cylinder assembly and removing cover (125).**

5. To disassemble the cylinder (121) assembly into its component parts conduct the following:
 - a. Use a press to compress the cover (125) enough to remove retainer ring (126). Slowly, and carefully, relax the load exerted on cover (125) by the springs (124) and (127). Remove cover and springs.
 - b. Remove washer (128).
 - c. Remove piston (123) assembly.
 - d. Disassemble piston assembly into component parts by removing retainer ring (111) and separating cylinder rod (108) from piston (123). Remove 'O' rings (122), (109) and (110). Discard 'O' rings.
6. Remove plunger (114) assembly and spring (113) from brake bracket (106).

Manual Drum Band Brake Disassembly

Optional feature. Refer to Dwg. MHP1372.

The winch does not have to be removed or disassembled to disassemble the manual band brake.

CAUTION

• **Release wire rope tension on the drum and disconnect main air supply line.**

1. Raise handle (135) to free brake bands (136 and 137).
2. Remove cotter pin (139) and pin (138).
3. Rotate brake link stud (141) counter-clockwise until free from brake handle.
4. Remove grip from brake handle (135). Loosen screws in brake handle until handle can be freed from brake band bracket, remove brake handle. Remove pivot nut (134).
5. Loosen capscrew (101), brake cam stop (132) will rotate to free position.
6. Remove cotter pin (144) and washer (142).
7. Loosen capscrews (112).
8. Spread brake band (137) apart slightly and slide out over drum flange. Rotate brake band around drum and remove.
9. Repeat this procedure for brake band (136).
10. Remove capscrews (112), washers (131), and adapter plate (145).
11. Press bushings (143) out of brake band pivot brackets.

Reduction Gear Disassembly

Refer to Dwg. MHP1248.

1. Place the reduction gear assembly on a clean work bench such that reducer housing (59) with oil seal (58) is down.
2. Remove thrust washer (34) and output carrier assembly (52).
3. Remove the input carrier assembly (69) by grasping the intermediate sun gear (45) and removing as an assembly. This may also remove the input sun gear (54). Ensure that thrust bearing (56) and thrust washers (55), located on the end of the input sun gear (54) are removed.

NOTICE

• **Do not disassemble planetary assemblies further than necessary to complete repairs. If planet gears (43) or (51) are disassembled, note the position of all spacers, roller bearings and shims to ensure correct reassembly.**

4. To disassemble an output planet gear (43) from the output carrier (35) conduct the following:
 - a. Before disassembly verify each gear (43) has a 0.005 to 0.032 inch (0.1 to 0.8 mm) end clearance.
 - b. Using a small punch, drive roll pin (37) fully into output planet pin (36).
 - c. Gently tap and slowly remove output planet pin (36) from output carrier (35). Using a punch, remove roll pin (37) from planet pin and discard.
 - d. Remove output planet gear (43) assembly. Take care to prevent internal roller bearings (41) in each gear from falling out during removal.
 - e. Note the position and quantity of the washers (38), (39) and (40) in each gear assembly. Keeping the washers separated, by assembly, will assist in re-installation.

NOTICE

• **If gear clearance is not within specification (0.005 to 0.032 inch [0.1 to 0.8 mm]) as determined in Step 4a., correct location/quantity of washers (38), (39) and (40) must be determined at assembly.**

- f. Unless the roller bearings (41) or spacer (42) must be replaced it is not recommended that these parts be separated or removed from the output planet gear assembly. Care must be taken to maintain the roller bearing position. The output planet pin (36) can be carefully reinserted into the gear to maintain bearing position until reassembly.
 - g. When planet gears are removed the thrust washer (44) may be removed from the inside of the output carrier (35).
5. To disassemble an input planet gear (51) from the input carrier (47) conduct the following:
 - a. Remove retainer ring (53) from input planet pin (49).
 - b. Unless the washers (39), roller bearings (50) or input planet gear (51) must be replaced it is not recommended that these parts be separated or removed from the input planet carrier. Care must be taken to maintain the roller bearing position. To remove the washers (39), input planet gear (51) and bearings (50) slide parts off of planet pin.
6. Remove the oil seal (58) and discard. Remove the caged needle bearing (57) only if replacing. To remove press bearing out of housing.

Free Spool Disassembly

Optional feature. Refer to Dwg. MHP1321.

1. Relieve pressure in the air lines and winch air components by operating the winch control several times after the air supply has been turned off.

WARNING

- **Shut off, bleed down and disconnect the air supply line before performing any disassembly procedures.**
- **Do not attempt repairs with load on wire rope.**

2. To assist in reassembly, place match marks on the housing (503) and outboard upright (26).
3. Remove capscrews (229) and pull the free spool shifter assembly (506) out of housing (503).

NOTICE

• **Spring (552) is compressed by handle (509). During disassembly do not lose latch (553) when pin (508) is removed.**

4. Press down on base of handle (509) and, using a pin punch or similar tool, drive out dowel pin (508). Separate parts: handle, latch (553), detent plate (510) and shifter (512).
5. Remove 'O' ring (404) from housing (503). Discard 'O' ring.
6. To remove dowel pin (551) from shifter (512) the pin must be heated to loosen the Loctite® bond.
7. Remove capscrews (1) and washers (511) securing cover (2) to housing (503).
8. Separate cover from housing. Remove and discard gasket (18).
9. Remove capscrews (502) securing housing to upright (26). Pull housing away from upright while pushing shaft support (505) towards upright until housing is removed.
10. Remove capscrews (504) and pull shaft support away from output shaft (28).

Cleaning, Inspection and Repair

Cleaning

Clean all winch component parts in solvent (except the drum brake bands and disc brake friction plates). The use of a stiff bristle brush will facilitate the removal of accumulated dirt and sediments on the housings, frame and drum. If bushings have been removed it may be necessary to carefully remove old Loctite® from the bushing bores. Dry each part using low pressure, filtered compressed air. Clean the drum brake band using a wire brush or emery cloth. Do not wash the drum brake band in solvent. If the drum brake band lining is oil soaked, it must be replaced.

Inspection

All disassembled parts should be inspected to determine their fitness for continued use. Pay particular attention to the following:

1. Inspect all gears for worn, cracked, or broken teeth.
2. Inspect all bushings for wear, scoring, or galling.
3. Inspect shafts for ridges caused by wear. If ridges caused by wear are apparent on shafts, replace the shaft.
4. Inspect all threaded items and replace those having damaged threads.
5. Inspect the drum band brake lining for oil, grease and glazing. If the drum band brake lining is oil-soaked, excessively greasy or overly glazed replace the brake band. Remove small glazed areas of band brake lining by sanding lightly with a fine grit emery cloth.
6. Measure the thickness of the drum band brake lining. If the drum brake band lining is less than 0.062 in. (2 mm) thick anywhere along the edges replace the brake band assembly.
7. Inspect motor cylinder (228) bores for signs of wear. Cylinders can be lightly honed, for any large scratches or wear patterns, replace cylinder assembly.

Repair

Actual repairs are limited to the removal of small burrs and other minor surface imperfections from gears, shafts, housings and machined surfaces. Use a fine stone or emery cloth for this work.

1. Worn or damaged parts must be replaced. Refer to the applicable parts listing for specific replacement parts information.
2. Inspect all remaining parts for evidence of damage. Replace or repair any part which is in questionable condition. The cost of the part is often minor in comparison with the cost of redoing the job.
3. Smooth out all nicks, burrs, or galled spots on shafts, bores, pins, or bushings.
4. Examine all gear teeth carefully, and remove nicks or burrs.
5. Polish the edges of all shaft shoulders to remove small nicks which may have been caused during handling.
6. Remove all nicks and burrs caused by lockwashers.

Assembly

General instructions

- use all new gaskets and seals.
- replace worn parts.
- assemble parts using match marks applied during disassembly. Compare replacement parts with originals to identify installation alignments.
- lubricate all internal parts with rust and oxidation inhibiting lubricant, ISO VG 100 (30W).

Thermoplastic Coated Parts Assembly

CAUTION

• **During application of thermoplastic coating to assemblies use a flame to localize the heat. Do not heat entire assembly. Assemblies contain gaskets, 'O' rings and other components that may be damaged by exposure to excessive heat.**

1. When assembling parts already coated, the mating areas can be heated to soften the coating enough to flow together and seal the parts.
2. When installing a new component in an assembly, remove coating from existing parts as necessary to ensure parts mate correctly.
3. Install fasteners and torque as required. Apply coating to bare areas as described in 'Thermoplastic Coating' repairing surfaces instructions in the "MAINTENANCE" section for areas larger than 1/16 inch (1.6 mm).
4. Allow the repaired area to cool. Quenching with water is acceptable. Rough spots, minor scorching and excess coating deposits can be wet sanded to remove the imperfections. To return the gloss finish, reheat the surface carefully.

Motor Assembly

Refer to Dwg. MHP1310.

NOTICE

- **When assembling the air motor keep the work area as clean as possible. Dirt and contaminants are the biggest source of component failure.**
- **Clean all components with a none residue solvent.**
- **Lubricate all 'O' rings with Dow Corning® 111 Valve Lubricant.**

1. Install 'O' rings (230) on spool (231) and lubricate.
2. Press the spool (231) into the motor housing bore from the motor adapter side until flush. Ensure 'O' rings are not damaged during installation.

NOTICE

- **If installing a new crankshaft assembly, new bearings (245) are included. These are used because of the new mating surface (pin (213)). See piston assembly for proper installation procedures.**

3. Clean the center bore of the motor housing and lubricate.
4. Take the locknut (202), tab washer (203), bearing (204) and rotary valve seal assembly (208) off the back half of the crankshaft assembly. Then insert the crankshaft assembly through the main cavity.
5. Lubricate the crankshaft and slide the rotary valve seal assembly (208) (with the curved end facing the rotary valve (208)) onto the shaft.
6. Hold this crankshaft assembly and press the bearing and retainer (204) in from the adapter side of the motor housing.
7. Place the tab washer (203) (curved surface up) onto the crankshaft and then locknut (202). The flat side of locknut (202) should be facing out and the curve of the locknut and tab washer should match.
8. Tighten locknut (202) to 60 in lb. (22 Nm). Use a wooden (or fiberglass) tool handle to lock the crankshaft. Place it through two of the cylinder ports in the motor housing and let the crankshaft pin (213) come to rest on it. Loosen locknut just enough to allow one of the locking tabs from the tab washer (203) to be bent into one of the slots in the locknut (202).
9. Rotate crankshaft assembly, crankshaft should spin freely, if not, correct problem before proceeding.

Piston Assembly

CAUTION

- **Use a press and supports to avoid damaging the piston rod. Press on the outer race of the bearings and support the piston rod as close to the bearing as possible.**

1. Apply Loctite® 609 to the bore of the piston rod (241) and the outside of bearing (247).
2. Press bearing (247) into piston rod (241) until bearing is centered in piston rod.
3. Press bearing (245) into large bore of link rod (244) until centered in rod.
4. Place link rod (244) over bearing (247) in piston rod.
5. Insert washers (248) on both sides of bearing (247), between link rod (244) and bearing (247).

- Align the bore of bearing (247), washers (248) and link rod (244).
- Apply Loctite® 609 to the bore of bearing (247).

⚠ CAUTION

• Do not allow Loctite® 609 to flow into the bearing, this can cause part failure and motor damage. Ensure that washers (248) are centered on the bearing. These are very thin and can be sheared off, creating metal particles which can cause component failure.

- Press pin (246) into bearing (247) until centered.
- Place 'O' ring (242) into groove on piston and lubricate.
- Place piston sleeve (243) over 'O' ring (242).

🔧 Piston Mounting

Position motor housing onto adapter side of housing.

- Rotate crankshaft pin (213) until it is opposite the square portion of the cylinder port in the motor housing.
- Insert a piston assembly through the motor cavity and out the cylinder port (with the square portion). Lift the piston rod up into this square area.
- Slowly rotate the crankshaft until the bearing (245) will slide onto the crankshaft pin.
- Repeat steps 2 and 3 for the other piston assembly.
- Insert setscrew (218) into the top of counterweight (214) and engage a couple of threads.
- Slide counterweight onto crankshaft pin.

⚠ CAUTION

• The flat side of the counterweight must face the piston rods with the raised portion facing away. Failure to do this will result in damage to components.

- Align the setscrew hole in the crankshaft pin (213) with setscrew (218) and tighten.
- The flats on counterweight must align within 1/16 in (2 mm) of the flats on the crankshaft. Use a small metal flat edge to check. Refer to Dwg. MHP1307.

Counterweight Alignment Check

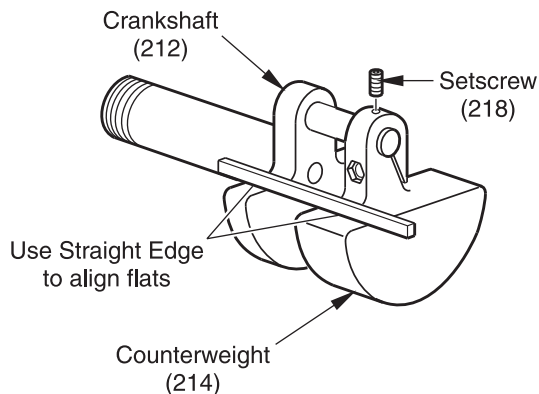

(Dwg. MHP1307)

⚠ CAUTION

• Failure to properly align counterweight on crankshaft may cause extreme motor vibration, resulting in damage to the winch motor.

- If greater than a 1/16 in (2 mm) difference between the counterweight and crankshaft flats then the end of the setscrew should be ground. Grind very small amounts off of setscrew. Refer to Dwg. MHP1276. Repeat process until tolerance is met. If this tolerance is exceeded then the crankshaft will be out of balance, resulting in extreme motor vibration and possible damage.

Setscrew (218) Adjustment

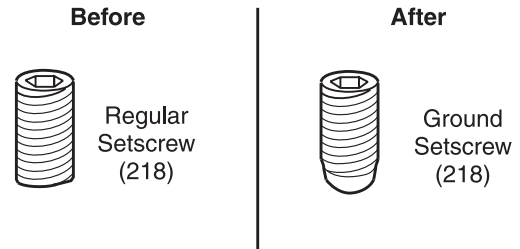

(Dwg. MHP1276)

- Tighten the socket head capscrew (216) to 185-195 in lb. (68-72 Nm), while holding flatwasher (215) centered on capscrew. Check tightness of setscrew (218).

🔧 Cylinder Assembly Installation

Position motor housing back on its side.

- Lubricate the inside of cylinders and pistons.
- Apply a 1/16 in (2 mm) bead of Loctite® 515 around the inboard cap (226) and outboard cap (227). Refer to Dwg. MHP1297.

Cylinder Cap Sealant Placement

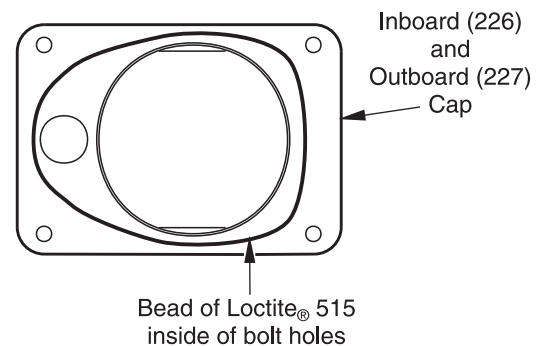

(Dwg. MHP1297)

- Place cylinder assembly over piston, push and twist into position on motor housing.

⚠ CAUTION

• Ensure that the inboard and outboard cylinder assemblies are in the correct position. This is noted by the offset position of the air inlet holes.

- Coat capscrews (229) with anti-seize compound. Insert capscrews through cap assemblies into motor housing and tighten to 145-150 in lb. (54-56 Nm).

🔧 Motor Cover Installation

- Apply a 1/16 in (2 mm) bead of Loctite® 515 around the motor cover (223). Refer to Dwg. MHP1318.

- Place cover assembly onto motor housing.
- Apply Loctite® 242 to capscrews (224) and insert into motor housing. Tighten to 40-50 in lb. (4.5-5.7 Nm).

Motor Cover Sealant Placement

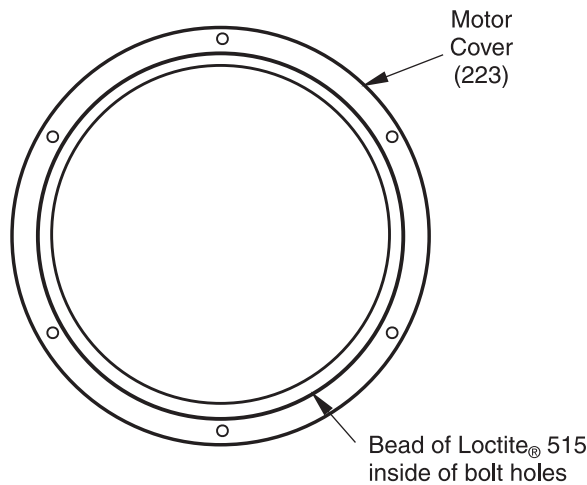

(Dwg. MHP1318)

Mounting Motor To Winch

- Assemble exhaust manifold (233) by inserting capscrews (224) through exhaust manifold and into motor housing. Tighten to 40-50 in lb. (4.5-5.7 Nm).
- Wrap a nylon sling around motor housing and, using a suitable hoist, slide motor assembly straight onto drive shaft (61), twisting motor to engage splines on shaft.
- Align bolt holes, with air inlet on motor housing facing up. Insert capscrews (221) through motor flange into adapter (71) and tighten to 33-36 ft lb. (45-49 Nm).
- Attach muffler assembly (234) to exhaust manifold (233).

Control Valve Assembly

Refer to Dwg. MHP1314.

NOTICE

• During assembly align parts using match marks made during disassembly.

- Install seal rings (315) on each end of valve body (316).
- Install valve body (316) into valve bushing (314).
- Install valve body retainer (305) with two capscrews (302) and lockwashers (304). Torque capscrews to 25 ft lbs (34 Nm).
- Install flange (318) and gasket (317) and secure using capscrews (302) and lockwashers (304). Torque capscrews to 25 ft lbs (34 Nm).
- If removed, reinstall spring retaining stud (306) and torque to 25 ft lbs (34 Nm).
- Install spring (303) and handle (300) on square shaft of valve body (316). The spring (303) ends must straddle the spring retaining stud (306) on throttle handle (300). Install roll pin (301).
- Check throttle handle moves fully left and right without sticking or binding. Throttle handle should center, by spring force, automatically when released.

Installation of Control Valve and Inlet Manifold

Refer to Dwg. MHP1314.

NOTICE

• Manifold (606) and cover (607) are bonded together and thermoplastic coated. If these components are separated then they must be re-bonded prior to assembly. Refer to the following:

Bonding Procedure:

- Clean mating surfaces of manifold (606) and cover (607). Apply a thin layer of Loctite® 515 to one mating surface.
 - Insert capscrews (614) through cover. These are just guides at this time.
 - Place cover onto manifold. Ensure bolt holes are aligned. Clamp cover and manifold together and allow sealant to cure.
 - Refer to 'Thermoplastic Coated Parts Assembly' to repair removed coating.
- Verify spool locating pin (613) is straight and installed in manifold (606). Position gasket (611) and manifold/cover assembly on motor housing. Install four capscrews (614) to clamp parts to motor housing (220). Torque capscrews to 108-112 in lb. (12-13 Nm).
 - Mount control valve assembly (260) and gasket (321) to cover such that handle is toward winch drum. Install four capscrews (331) and torque to 33-36 ft lb. (45-49 Nm).
 - Connect brake line to swivel elbow fitting (319) on control valve housing.
 - Connect air supply line to control valve.

Installation of Remote Control Valve and Inlet Manifold

Optional feature. Refer to Dwg. MHP1304.

- Verify spool locating pin (613) is straight and installed in manifold (606). Position gasket (611) and manifold on motor housing. Apply Loctite® 242 to capscrew (614) threads and install four capscrews to clamp manifold to motor housing (220). Torque capscrews to 108-112 in lb. (12-13 Nm).
- Apply Loctite® 515 to valve assembly mounting surface and install on cover (607). Apply Loctite® 242 to capscrew (615) threads and install four capscrews to clamp cover to valve assembly. Torque capscrews to 55 ft lb (74 Nm).
- Apply Loctite® 515 to manifold surface and install cover and valve assembly. Position assembly such that valve exhaust port is away from the winch drum. Install four capscrews (608) and torque to 21 ft lb. (28 Nm).
- Connect brake line to connector fitting (621).
- Connect pendant hoses to valve fittings.
- Connect air supply line to control valve.

Emergency Stop Assembly

Optional feature. Refer to Dwg. MHP1331.

- Place bracket (527) on bottom of shut off valve (522). Locate bracket long end on the shut off valve air out side. Loosely install capscrews (528).
- Place bracket (529) on bottom of shut off valve. Locate bracket face to rear (as viewed from muffler side) of shut off valve. Install capscrews (531).
- Tighten capscrews (528) and (531).

4. Insert capscrews (543) through Delta 'P' valve (533) and into bracket (529). Tighten capscrews.
5. Insert elbow (537) into shuttle valve (517). Tighten elbow and adjust alignment to shut off valve as shown in Dwg. MHP1331.
6. Install shuttle valve/elbow assembly into top port of shut off valve. Locate shuttle valve over shut off valve air inlet port.
7. Install bracket (539) to top of shut off valve and secure using capcrews (538).
8. Attach emergency stop valve (541) to bracket (539) using capscrews (542).

NOTICE

• **When connecting fittings ensure that air lines are connected as shown in Dwg. MHP1331. Various fitting thread types are used (i.e., metric, British, JIC and NPT). Ensure the correct mated threads are joined; do not force fittings.**

9. Connect fittings and route air lines as shown in Dwg. MHP1331.
10. Insert capscrews (526) through bracket (527) and slide spacers (532) onto capscrews. Place this entire assembly onto the bolt holes on the air inlet side of the control valve assembly and loosely tighten capscrews (526).
11. Connect union (536) and tighten.
12. Tighten capcrews (526).
13. Connect fittings (513) to manifold connectors (534).
14. Insert nipple (524) into muffler. Insert this assembly into elbow (523) and tighten.
15. Insert elbow (523) into exhaust port and tighten. Locate muffler in position noted during disassembly.

Overload Device Assembly

Optional feature. Refer to Dwg. MHP1323.

1. Insert nipple (578) into remote valve assembly (355).
2. Insert bushing (535) into outlet port in shut off valve (522) and tighten.
3. Place shut off valve (522) onto nipple (578) and tighten. Ensure that exhaust port is facing same direction as exhaust port on remote valve assembly.
4. Insert elbow (537) into shuttle valve (517) and tighten. Position elbow as shown in Dwg. MHP1323.
5. Insert shuttle valve/elbow assembly in shut off valve (522) and tighten. Locate shuttle valve over the air outlet port.
6. Insert capscrews (531) through bracket (529) into shut off valve and tighten.
7. Insert capscrews (543) through Delta 'P' valve (533) and into bracket (529) and tighten.

NOTICE

• **When connecting fittings ensure that air lines are connected as shown in Dwg. MHP1323. Various fitting thread types are used (i.e., metric, British, JIC and NPT). Ensure the correct mated threads are joined; do not force fittings.**

8. Connect fittings and route air lines as shown in Dwg. MHP1323.
9. Follow steps 1 through 6 of 'Installation of Remote Control Valve and Inlet Manifold' section.

Reduction Gear Assembly

Refer to Dwg. MHP1248.

1. Press caged needle bearings (57) into reducer housing (59). With oil seal (58) lip facing towards reducer housing, install oil seal in reducer housing.
2. Install thrust washer (44) in groove in output planet carrier (35).
3. Determine planet gear (43) to carrier (35) end clearance for each gear:

NOTICE

• **Shim output carrier (35) planet gears for 0.005 to 0.032 inch (0.1 to 0.8 mm) end clearance between gear (43) and carrier.**

- a. If not noted during disassembly, determine planet gear (43) end clearance. Place planet gear in carrier (35) and insert pin (36) to hold in place. Slide gear against one side of carrier wall. Measure the gap between opposite side of carrier interior face and gear. Repeat for each gear.
- b. Measure the width of two washers (38), (39) and (40). Combine the amounts of the washers and subtract from the amount of the gap determined in step a. Add or remove washers as necessary to establish a 0.005 to 0.032 inch (0.1 to 0.8 mm) end clearance. Repeat for each gear.
4. Assemble and install planet gear assembly in the output carrier (35):
 - a. Cut two pieces of cardboard into 3 inch (76 mm) squares. Place planet gear (43) on one of these pieces and place pin (36) into hole in center of gear. Insert eighteen roller bearings (41) between pin and gear. Take care to ensure initial pins inserted do not tip over.
 - b. Insert spacer (42) followed by the second set of 18 roller bearings.
 - c. Place half of the washers required to establish end clearance (refer to Step 3b.) over pin and against gear face. Grasp assembly, including cardboard, and flip over onto second piece of cardboard. As gear slides down pin onto bottom cardboard, allow pin to push top piece of cardboard off.
 - d. Place other half of the washers required to establish end clearance (refer to Step 3b.) over pin and against gear face. Grasp assembly carefully and move to carrier.
 - e. Slide assembled gear partially into position in carrier, up to pin. Slowly remove pin taking care not to let bearings tip over or fall. Carefully slide gear assembly into carrier, aligning hole in gear with hole in carrier.
 - e. Place output planet pin (36) into one end of output carrier (35). Ensure end of pin, with hole, is inserted such that it will line up with hole in carrier for roll pin (37) installation.
 - f. Slide pin (36) until hole in pin and hole in carrier are aligned. Verify end clearance tolerance is 0.005 to 0.032 inch (0.1 to 0.8 mm). If required, add or remove washers to adjust clearance. Secure pin to carrier using roll pin (37). Carefully tap roll pin into place taking care not to 'mushroom' the head. Tap until level with top of carrier.
 - g. Repeat procedure for remaining gears.

5. To install planet gear assemblies on the input carrier (47) conduct the following:
 - a. Ensure pin (49) is securely attached to input carrier (47). If loose, carefully remove pin. Clean pin and mating surface on carrier. Coat end of pin and carrier mating surface with Loctite® 620 and install pin. Allow to cure.
 - b. Install washer (39) and input planet gear (51) on pin (49).
 - c. Lubricate roller bearings (50) and install sixteen bearings in input planet gear (51).
 - d. Install second washer (39) on pin (49). Secure parts on pin using retainer ring (53).
6. Install intermediate sun gear (45) in input carrier assembly. Place retainer rings (46) on each side of carrier (47) to secure sun gear in place.
7. Place thrust washers (55) and thrust bearing (56) on input sun gear (54). Place assembly in input carrier assembly (47) by aligning gear teeth of planet gears (51) with gear teeth on input sun gear.
8. Install input carrier assembly in reducer housing (59).
9. Install output carrier assembly in reducer housing. Ensure gear teeth of planet gears (43) align with intermediate sun gear (45) gear teeth.
10. Install thrust washer (34).
11. With drum standing on end, place reduction gear assembly into drum. Place Loctite® 515 on mating surfaces of housing (59) and cover (33). Align the two recessed cutouts in the housing with the fill and drain plug ports in the cover. Secure in place by evenly installing six capscrews (32). Torque capscrews to 60 ft lbs (81 Nm).
12. Cover the reduction gear to prevent dirt and contaminants from entering assembly and place in a safe position until ready for assembly to winch uprights.

Winch Assembly

Refer to Dwg. MHP1248 and 1324.

NOTICE

• Unless otherwise stated capscrew torque values listed are for lubricated or plated threads. This assembly uses “blue bolts” in numerous locations. These are plated and should not be lubricated.

1. Using a hoist, support the drum.
2. Install bearing (30) in inboard (motor end) upright (68). With oil seal (29) lip facing towards the motor, install oil seal in inboard upright.
3. Install output shaft (28), bearing (30) and oil seal (29) in outboard upright (26). Oil seal lip must face toward the brake. Install the outboard upright onto drum by aligning splines of output shaft to reduction gear output carrier assembly splines.
4. If equipped with automatic drum brake, install the drum band brake bracket and piston assemblies. Do not attach the brake band assembly (104). Refer to the ‘Drum Band Brake’ section for instructions.
5. Install coupling (60) on drive shaft (61) and install on end of the input sun gear (54), located in the reduction gear assembly.
6. If equipped with automatic drum brake, place brake band assembly (104) onto drum brake flange. Place inboard (motor end) upright (68) on drum.

7. **For standard winch:** loosely attach the sideframes (64) and (65) to the uprights (26) and (68) using four capscrews (66) for each sideframe. Tighten capscrews and torque to 75 ft lbs (102 Nm) for dry threads, or 55 ft lbs (75 Nm) if thread lubrication is used.
8. **For Open Frame (Face) winch:** Refer to Dwg. MHP1324. Loosely attach the rear sideframe (64), using four capscrews (66) to uprights (26) and (68).
 - a. If noted during disassembly, place washers (584), in quantities and locations recorded, and bars (571) between sideframes (571) and (573). Secure using capscrews (572) and torque to 150-175 ft lbs (203-237 Nm). Go to step 8.c.
 - b. If washer (584) locations and quantities were not recorded, loosely attach sideframe (571) to upright (26) and sideframe (573) to upright (68) using capscrews (574). Using washers and bars (570), determine the correct arrangement of washers required to ensure sideframes are even with drum (62) flange edge. The washers (584) must be evenly distributed with an equal number located on each end of the bars. Once quantities are determined, remove the sideframes and reassembly as described in step 8.a.
 - c. Place open frame assembly onto uprights (26) and (68). Ensure sideframe (571) is located on upright (26) and sideframe (573) is located on upright (68). Place washers (585) on capscrews (574) and secure frame assembly to uprights. Torque capscrews to 75 ft lbs (102 Nm).
 - d. Secure rear sideframe (64) to uprights, torque capscrews (66) to 75 ft lbs (102 Nm).
9. Align holes in motor adapter (71) and install on upright. Secure with six washers (74) and capscrews (73). Torque capscrews to 125 ft lbs (170 Nm) for dry threads, or 95 ft lbs (129 Nm) if thread lubrication is used.
10. If equipped, attach band brake assembly (104) as described in the ‘Drum Band Brake Assembly’ section.

Disc Brake Assembly

Refer to Dwg. MHP0947.

1. Install bearing (21) into support plate (19) and secure with retainer ring (22).
2. In this order, place spacer (11), sprag clutch (16), outer race (12) and spacer (11) on inner race (10). Test sprag clutch operation. Refer to Dwg. MHP0667.

NOTICE

• Correct sprag clutch installation prevents clockwise rotation (brake engages) and allows counterclockwise rotation when viewed from the end cover (2) end of the brake assembly.

WARNING

• Incorrect assembly of the sprag clutch will adversely affect winch operation. In haul-in operation, sprag clutch will be engaged resulting in restricted winch operation. In neutral and payout positions, the sprag clutch can rotate resulting in brake not holding load. Ensure the sprag clutch is correctly installed.

3. Install assembly on support plate (19).
4. Install twelve springs (17) in holes on inside of support plate (19).
5. Install gasket (18) and pressure plate (15).

6. Determine correct alignment of end cover (2), housing (6) and support plate (19) by checking matchmarks placed during disassembly, or by placing housing on support plate and matching capscrew holes.

Sprag Clutch Assembly

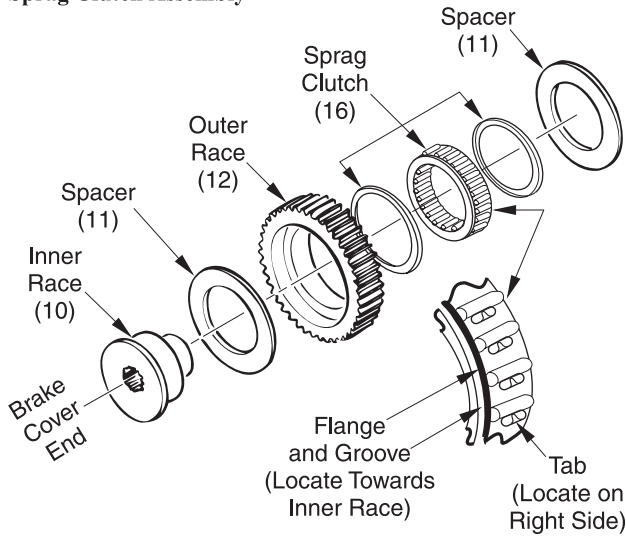

(Dwg. MHP0667)

7. Correctly align with dowel slots on the housing (6) and install six separator plates (14) and five friction plates (13) in the following order:
 - a. Place two separator plates, two friction plates, two separator plates, three friction plates and two separator plates. Refer to Dwg. MHP0946.

⚠ WARNING

• **Failure to correctly arrange friction and separator plates will result in erratic brake operation. Sudden brake applications may cause winch and/or wire rope damage resulting in a falling load.**

8. Install the three dowel pins (9) in housing (6). Apply Loctite® 515 sealant on mating surfaces of housing and end cover (2). Install housing by aligning dowel pins with separator (14) and friction plate (13) grooves and, also aligning capscrew holes in housing with holes in end cover.
9. Install ring (4), and diaphragm support plate (5). Support plate radius must be next to diaphragm (3).
10. Install diaphragm (3) and end cover (2).
11. Locate as shown on Dwg. MHP0947 and install two capscrews (1). Evenly and alternately tighten capscrews to compress springs. Torque capscrews to 18 ft lbs (24 Nm).
12. Install brake shaft (25) and place assembly on outboard (opposite motor end) upright (26). Align capscrew holes such that the breather (8) is slightly off top dead center. Install six capscrews (1). Torque capscrews to 18 ft lbs (24 Nm). Install exhaust valve (79), elbow fitting (80) and connect air hose (75) to elbow fitting.
13. Winch drum **may** rotate in the haul-in direction and **must not** rotate in the payout direction, unless air is applied to the brake, when assembled properly.

Brake Disc Assembly Drawing

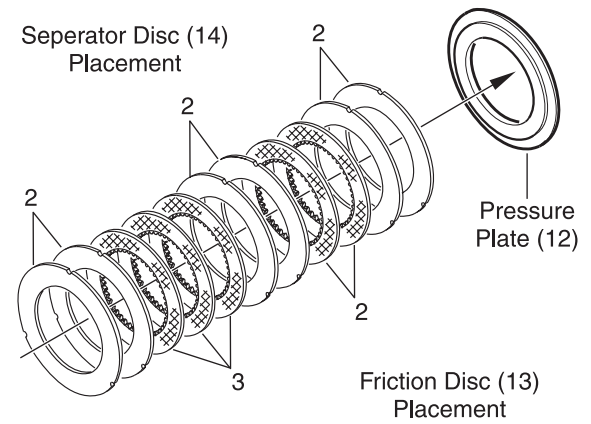

(Dwg. MHP0946)

Manual Drum Band Brake Assembly

Optional feature. Refer to Dwg. MHP1372.

1. Press bushings (143) into brake band pivot brackets. Bushing flanges must be to the motor upright side.
2. Attach adapter plate (145) to upright (68) loosely with capscrews (112) (apply Loctite® 242 to threads) and washers (131).
3. Place brake band (136) onto drum and rotate around drum (close to mounting position). Spread brake band (136) apart slightly and slide in over drum flange. Place brake band pivot bracket over pin in adapter plate (145).
4. Repeat this procedure for brake band (137).
5. Place washer (142) over pin in adapter plate (145) and secure with cotter pin (144).
6. Insert pivot nut (134) into brake handle (135).
7. Place brake handle (135) into bracket in brake band (136) and tighten screws in handle. Slide grip over brake handle.
8. Place brake link stud (141) into pivot nut (134) and rotate clockwise until approximately 1 in. (25 mm) of threads are exposed.

NOTICE

• **Refer to 'ADJUSTMENT' section for adjusting brake.**

9. Lift up brake handle (135) until hole in brake link stud (141) and bracket in brake band (137) are aligned. Insert pin (138) and secure with cotter pin (139).
10. Push brake handle (135) down to the lock position.
11. Tighten capscrews (112).
12. Adjust cam stop (132). Refer to 'ADJUSTMENT' section for adjusting brake.

Automatic Drum Band Brake Assembly

Optional feature. Refer to Dwg. MHP1281.

For ease of assembly install bracket (106), cylinder (121) assembly and brake handle stop to motor end upright (68) prior to assembling upright to drum.

1. Assemble the brake cylinder (121) as follows:
 - a. Install 'O' ring (122) on piston (123).
 - b. Heavily coat the piston and cylinder rod with "LubriPlate" MO-LITH No. 2 or equivalent lubricant. Install 'O' rings (109) and (110) on cylinder rod (108). Place cylinder rod (108) into piston (123) and secure in place using retainer ring (111).
 - c. Install piston assembly in brake cylinder (121).

- d. Install washer (128) and springs (124) and (127).

DANGER

• **Springs (124) and (127) exert a considerable force on cover (125) when assembled. Extreme care must be taken when assembling and installing cover (125) and retainer ring (126).**

- e. Using a press, slowly compress cover (125) and springs until the retainer ring groove is accessible. Install retainer ring (126). To ensure that retainer ring is properly installed, tap the end of the retainer ring with a punch until the entire retainer ring rotates in brake cylinder groove. Slowly release press and ensure retainer ring securely holds cover in place.
2. If not accomplished during 'Winch Assembly' steps, install bracket (106) to inside of motor end upright (68) and secure in place using capscrews (107) and (112). Torque capscrews to 85 ft lbs (115 Nm).
3. Assemble roller (116) in plunger (114) and secure using dowel pin (115). Heavily coat the plunger assembly with "LubriPlate" MO-LITH No. 2 or equivalent lubricant. Install spring (113) and plunger assembly in brake bracket (106). Align groove in plunger towards hole in motor end (68) upright.
4. Align cylinder rod roller surface to groove in plunger. Turn cylinder (121) clockwise until snug. Adjust cylinder (121) such that the air hose connection port is horizontal and towards the motor.

Conduct the following when the winch is assembled, but prior to mounting to the foundation. The motor end of the winch should be raised enough to allow access to the brake components located on the inside surface of the inboard (motor end) upright (68).

5. Place spacer (105) between upper brake band flange and bracket. Attach band assembly (104) to bracket (106) using three capscrews (101), spacers (102) and spacer tubes (103). Torque capscrews to 55 ft lbs (75 Nm).
6. Install pivot bar (119) and capscrew (120) through lower flange of brake band assembly (104). At lowest point of threads, place a bead of Loctite® 680 and install jam nut (117) fully. Jam nut threads must become coated with sealant. Install second jam nut (117) to approximately the middle of the thread length. Thread capscrew (120) into bottom of plunger (114) a minimum of five thread lengths. Lock in place, against plunger, using jam nut (117). Adjust brake as described in the 'Drum Band Brake Adjustment' section.

Adjusting Automatic Drum Band Brake

Optional Feature. Refer to Dwg. MHP1281.

CAUTION

• **This adjustment is done after a rebuild. It is only a rough adjustment intended to remove major slack prior to adjusting with a load.**

This procedure can be done at a work bench using a 50 psig air supply applied to the brake cylinder. After completion of this procedure the brake must further be adjusted using the recommended air supply and a test load.

1. Insert a length of 3/8 inch NC threaded rod, fully into the cylinder rod (108). With the brake band slack and no air supplied to the brake, push the end of the threaded rod to position the plunger all the way inside the brake bracket (106). Place a nut on the threaded rod, and locate nut until it is just touching the cover (125). Apply air to the brake. The threaded rod should move out from the cylinder approximately 1 inch (25 mm).
2. Tighten capscrew (120) in plunger (114) to remove slack from band brake. Release air pressure. The nut should move closer to the end cover (125) and stop.
3. Repeat step 1 until the nut stops at approximately 9/16 inch (14 mm) from the cover (125).
4. Refer to further adjusting in 'Automatic Drum Brake Adjustment'.

Freespool Assembly

Optional feature. Refer to Dwg. MHP1321.

1. Apply Loctite® 609 to dowel pin (551) and install into end of shifter (512).
2. For steps 3 through 5, it is recommended that the shifter (512) be secured using a vise. Care should be taken to ensure shifter is not damaged by the vise. Use leather or copper-covered vise jaws to prevent scoring. Locate shifter in vise with dowel pin placed at bottom.
3. Lubricate spring (552) with grease and place into shifter. Locate latch (553) on end of spring.
4. Slide detent plate (510) onto shifter and seat against raised edge of shifter.
5. Place base of handle (509) into shifter slot. Using handle, push against latch to compress spring until hole in handle base and hole in shifter slot are aligned. Press dowel pin (508) in hole on one side of shifter slot, through handle and into hole in other side of shifter slot. Center the dowel pin. Remove assembly from vise.
6. With output shaft (28) installed in winch upright, attach shaft support (505) to output shaft with capscrews (504). Tighten capscrews.
7. Lightly lubricate shaft support mating surface.
8. Lubricate 'O' ring (404) and install into groove in housing (503) shifter port.
9. Fully slide housing over lubricated mating surface of shaft support.
10. Install shifter assembly into shifter port on housing with handle pointing down. Do not force assembly completely. It is necessary to align the dowel pin to shaft support groove. To do this slide housing with shifter assembly in and out on shifter shaft as necessary, while pressing on shifter assembly until dowel pin slips into support shaft groove.
11. Install capscrews in detent plate (510) to secure to housing. Tighten capscrews.
12. To locate the assembly to the correct position, with the handle pointing down and on the right hand side of the housing as viewed from the end opposite the motor, conduct the following:
 - a. Rotate housing to align capscrew holes in upright (26). Position handle on right and pointing down.

NOTICE

• **During this step the shaft support (505) should remain in position with the output shaft (28) fully engaged in the upright (26).**

- b. Install capscrews (502) and secure housing to upright. Torque capscrews to 18 ft lbs (24 Nm).
- 13. Visually verify free spool operation. Refer to 'Free Spool' in the "OPERATION" section for instructions. During operation observe the shaft support (505) to determine movement.
 - a. When in 'Free Spool Position' the shaft support should shift out, towards the end of the housing, as the handle is rotated.
 - b. When in 'Non-Free Spool Position' the shaft support should shift in, towards the upright. The drum may require slight rotation to correctly align the output shaft to the upright during shifting.
 - c. There should be no indication of sticking or binding during operation of the free spool.
- 14. Place gasket (18) and cover (2) onto housing. Align holes and install capscrews (501) and washers (511). Torque capscrews to 12-15 ft lbs (16-20 Nm).

Drum Guard Assembly

Optional feature. Refer to Dwg. MHP0658.

1. Place drum guard (590) on rear (drum brake side) sideframe (64) with the longer inside tab located under the sideframe edge and the smaller outside tabs located on top of the sideframe edge.
2. Place washers (593) on brackets (591). Install washers in quantities required to remove any 'play' or gap between drum guard and brackets.
3. Align brackets (591) on mounting holes in uprights (26) and (68). Secure in place with capscrews (592).

Testing

Operational Test

Prior to initial use, all new, altered or repaired winches shall be tested to ensure proper operation.

1. Check oil level in reduction gear assembly and disc brake is correct. Top off levels as required before operation as described in the "LUBRICATION" section.
2. To initially 'break in' new or overhauled motors, operate winch without load, in both directions, for one hour at 100 - 200 RPM.
3. Check operation of brakes. Adjust if necessary as described in the "MAINTENANCE" section.
4. Check operation of limit switches, locking mechanisms and all safety devices when equipped.
5. Check foundation mounting fasteners are secure.
6. If equipped, install drum guard.

Load Test

Prior to initial use, all new, extensively repaired, or altered winches shall be load tested by or under the direction of a person trained in safety and operation of this winch and a written report furnished confirming the rating of the winch. Test loads shall not be less than **100%** of rated line pull at mid drum and should not exceed **125%** of the rated line pull at mid drum. To test the winch at **125%** of the rated load at mid drum apply the following load:

FA2A Winch 125% Test Load 5,000 lb. (2,268 kg)

NOTICE

• Testing to more than 125% of rated line pull may be required to comply with standards and regulations set forth in areas outside the USA.

WINCH DRAWINGS AND PARTS LISTS TABLE OF CONTENTS

	Page
Winch Cross Section Drawing (MHP1335)	37
Winch Assembly Parts Drawing (MHP1248)	38
Winch Assembly Parts List	39
Motor Assembly Parts Drawing (MHP1310)	40
Motor Assembly Parts List	41
Disc Brake Assembly Parts Drawing (MHP0947)	42
Disc Brake Assembly Parts List	43
Automatic Drum Band Brake Assembly Drawing (MHP1281) and Parts List	44
Manual Drum Band Brake Assembly Drawing (MHP1372) and Parts List	45
Control Valve Assembly Parts Drawing (MHP1314)	46
Control Valve Assembly Parts List	47
Remote Pendant and Control Valve Assembly Parts Drawing (MHP1304)	48
Remote Pendant and Control Valve Assembly Parts List	49
Control Air Valve Assembly Drawing (MHP1305) and Parts List	50
Remote Pendant Assembly with Emergency Stop Drawing (MHP1376) and Parts List	51
Emergency Stop and Overload Assembly Parts Drawing (MHP1331)	52
Emergency Stop and Overload Assembly Parts List	53
Remote Emergency Stop and Overload Device Assembly Parts Drawing (MHP1323)	54
Remote Emergency Stop and Overload Device Assembly Parts List	55
Open Frame (Face) Assembly Drawing (MHP1324) and Parts List	56
Drum Guard Assembly Drawing (MHP0658) and Parts List	57
Free Spool Assembly Drawing (MHP1321) and Parts List	58
Air Preparation Assembly Drawing (MHP0233) and Parts List	59
Accessories and Kits Parts List	59
Winch Label/Tag Location Drawing (MHP1337)	60
Winch Label Tag Location Parts List	61
Parts Ordering Information	62

WINCH CROSS SECTION DRAWING

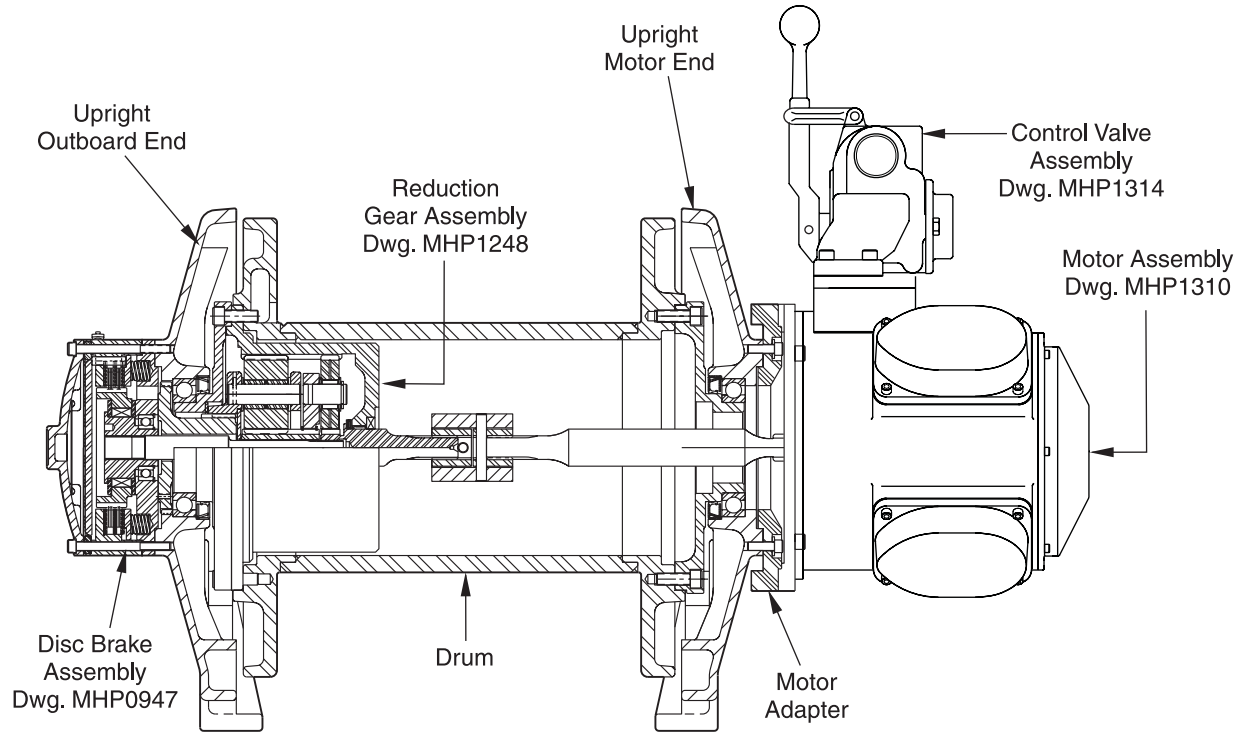

(Dwg. MHP1335)

WINCH ASSEMBLY PARTS DRAWING

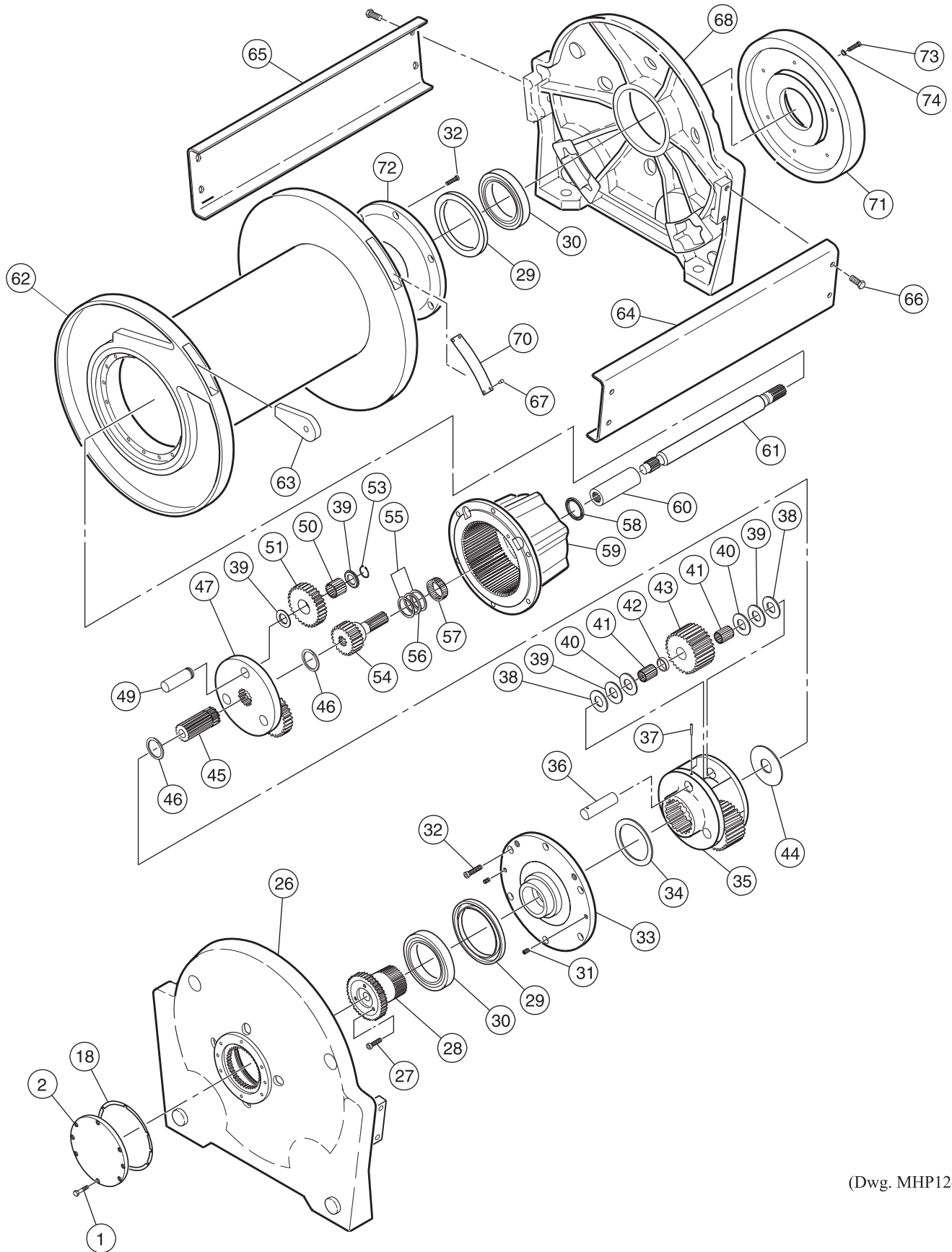

(Dwg. MHP1248)

WINCH ASSEMBLY PARTS LIST

ITEM NO.	DESCRIPTION OF PART	QTY TOTAL	PART NUMBER	ITEM NO.	DESCRIPTION OF PART	QTY TOTAL	PART NUMBER
1	Capscrew (1)	6	71266613	69	Input Carrier Assembly (2)	1	25151
2	End Cover (1)	1	21732	45	Intermediate Sun Gear	1	25146
• 18	Gasket (1)	1	71262257	46	Retainer Ring	2	71303309
26	Upright, Outboard End	1	24871	47	Input Carrier	1	25145
27	Capscrew (1)	3	71266936	49	Pin, Input Planet	3	24790
28	Output Shaft	1	24817	50	Bearing	54	71113211
• 29	Oil Seal	2	71293625	51	Gear, Input Planet	3	25147
• 30	Bearing	2	71293633	53	Retainer Ring	3	71113237
48	Reduction Gear Assembly (2)	1	25150	54	Input Sun Gear	1	25148
31	Plug	2	71267561	55	Thrust Washer	2	71113203
32	Capscrew	12	71306435	56	Thrust Bearing	1	71113195
33	Cover	1	25032	57	Bearing	1	71113187
34	Thrust Washer	1	25035	• 58	Oil Seal	1	71113179
52	Output Carrier Assembly (2)	1	25152	59	Reducer Housing	1	20672
35	Carrier	1	23898	60	Shaft Coupling	1	25482
36	Pin, Output Planet	3	20386	63	Wire Rope Anchor (4)	1	25539
• 37	Pin, Roll	3	71267793	66	Capscrew	8	71264683
38	Washer (0.123 inch thickness)	Refer to Note (3)	71146807	67	Drive Screw	4	50915
39	Washer (0.06 inch thickness)		71113229	68	Upright, Motor End	1	24893
40	Washer (0.092 inch thickness)		71113260	70	Label, Cover Anchor Pocket	1	71297824
41	Bearings, Roller		108	71113252	71	Motor Adapter	1
42	Spacer	3	20389	72	Cover (1)	1	25071
43	Gear, Planet	3	23899	73	Capscrew	6	54558
44	Thrust Washer	1	25153	74	Washer	6	71304844
Drive Shaft without Drum Brake				Drive Shaft with Drum Brake			
61	Short Drum (7 in)	1	25203	61	Short Drum (7 in)	1	25292
	Medium Drum (13-1/2 in)		25204		Medium Drum (13-1/2 in)		25291
	Long Drum (20 in)		25289		Long Drum (20 in)		25290
	Extra Long Drum (24 in)		26205		Extra Long Drum (24 in)		26206
Wire Rope Drum without Drum Brake				Wire Rope Drum with Drum Brake			
62	Short Drum (7 in)	1	25111	62	Short Drum (7 in)	1	25316
	Medium Drum (13-1/2 in)		24923		Medium Drum (13-1/2 in)		25353
	Long Drum (20 in)		25280		Long Drum (20 in)		25351
	Extra Long Drum (24 in)		25784		Extra Long Drum (24 in)		25751
Sideframe (Rear) without Drum Brake				Sideframe (Rear) with Drum Brake			
64	Short Drum (7 in)	1	24901-1	64	Short Drum (7 in)	1	25424-1
	Medium Drum (13-1/2 in)		24901-2		Medium Drum (13-1/2 in)		25424-2
	Long Drum (20 in)		24901-5		Long Drum (20 in)		25424-3
	Extra Long Drum (24 in)		24901-7		Extra Long Drum (24 in)		25424-4
Sideframe (Front) without Drum Brake				Sideframe (Front) with Drum Brake			
65	Short Drum (7 in)	1	24901-1	65	Short Drum (7 in)	1	24901-6
	Medium Drum (13-1/2 in)		24901-2		Medium Drum (13-1/2 in)		24901-4
	Long Drum (20 in)		24901-5		Long Drum (20 in)		24901-3
	Extra Long Drum (24 in)		24901-7		Extra Long Drum (24 in)		24901-8

• Recommended spare.

Notes: (1) Items 1, 2 and 18 are replaced by items 1, 2 and 18 of Dwg. MHP0947 on winches with a disc brake. Capscrews, item 27 are not required on units with a disc brake. Cover (item 72) not used on winches with drum band brake.

(2) Winch Reduction Gear Assembly includes items 31, 33, 34, the Output Carrier Assembly (items 35 through 44), the Input Carrier Assembly (item 39 [quantity 6] and items 45 through 53), and items 51 through 59.

(3) Washers (items 38 through 40) must be installed in quantities necessary to establish end clearances noted in the "MAINTENANCE" section.

(4) Wire rope anchor for 3/8 to 5/8 inch (10 to 16 mm) wire rope only.

MOTOR ASSEMBLY PARTS DRAWING

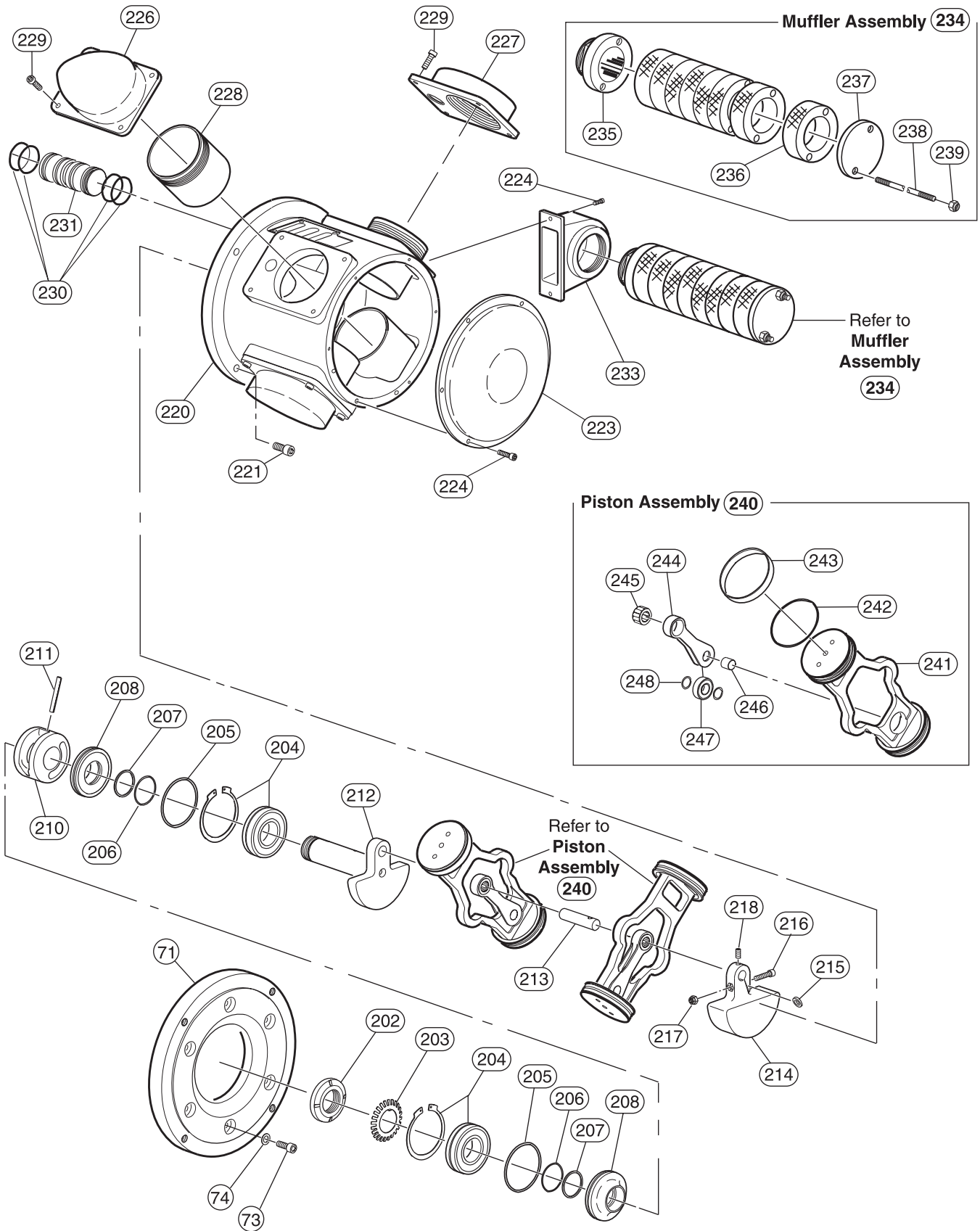

(Dwg. MHP1310)

MOTOR ASSEMBLY PARTS LIST

ITEM NO.	DESCRIPTION OF PART	QTY TOTAL	PART NUMBER	ITEM NO.	DESCRIPTION OF PART	QTY TOTAL	PART NUMBER
200	Motor Assembly ATPM15	1	26135	224	Capscrew	8	71307292
71	Motor Adapter	1	25445	226	Inboard Cap	2	24971
73	Capscrew	6	54558	227	Outboard Cap	2	24972
74	Washer	6	71304844	228	Cylinder	4	24970
* 202	Locknut	1	71293104	229	Capscrew	16	71307284
* 203	Washer, Tab	1	71293096	• 230	'O' Ring	4	71328090
* 204	Bearing (w/retainer)	2	71287114	231	Spool	1	26131-1
* 205	'O' Ring	2	71291363	233	Exhaust Manifold	1	25003
* 206	'O' Ring	2	51768	234	Muffler Assembly (1)	1	25710
* 207	Ring	2	71287163	235	End Cap, Threaded	1	25711
* 208	Rotary Valve Seal	2	24974	236	Muffler Body Segments	8	25712
* 210	Rotary Valve	1	24973	237	Cap	1	25713
* 211	Pin, Dowel	1	71304851	238	Rod, Threaded	2	25714
* 212	Crankshaft	1	24967	239	Locknut	2	50852
* 213	Pin, Crankshaft	1	24978	240	Piston Assembly	2	25726
214	Counterweight	1	24968	* 241	Piston Rod	2	24962-2
215	Washer	1	71300347	* 242	'O' Ring	4	71311773
216	Capscrew	1	71316764	* 243	Piston Sleeve	4	24964-1
217	Locknut	1	71316756	* 244	Link, Rod	2	24966
218	Setscrew	1	71300719	* 245	Bearing	2	71287130
220	Motor Housing	1	23305	* 246	Pin	2	24965
221	Capscrew	4	71306443	* 247	Bearing	2	71287122
223	Motor Cover	1	26134	* 248	Washer	4	71296263

• Recommended spare.

Notes:

- (1) Muffler Assembly (Item 234) consists of item numbers 235 through 239.
- * Parts not sold separately. Refer to Motor Assembly Kit list.

MOTOR ASSEMBLY KIT	PART NUMBER	DESCRIPTION OF KIT CONTENTS
Crankshaft Assembly Kit	25729	Consists of items 202 through 213 and 245.
Piston Assembly (240)	25726	Consists of items 241 through 248.
Bearing Kit	25725	Consists of items 245 through 248.
Piston Ring Kit	25724	Consists of items 242 and 243.
Inner Cover Assembly Kit	25727	Consists of items 226, 228 and 229.
Outer Cover Assembly Kit	25728	Consists of items 227 through 229.

DISC BRAKE ASSEMBLY PARTS DRAWING

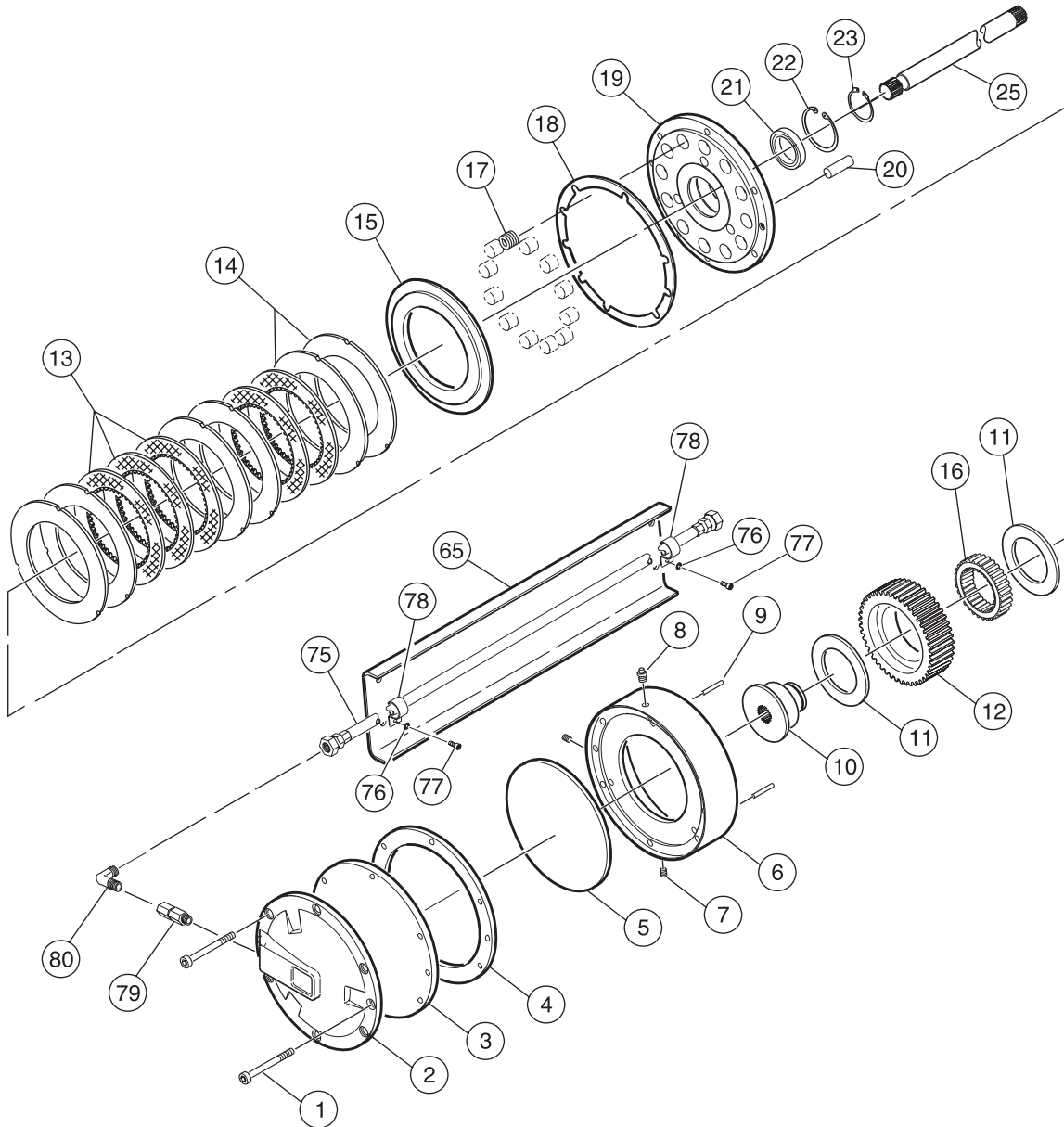

(Dwg. MHP0947)

Note: Standard winches may be provided with the brake cover release port located at either the 9 o'clock (left) or the 6 o'clock (bottom) position as viewed from the brake end of the winch. On Open Frame (Face) winches, the brake cover release port is located at the 3 o'clock (right) position as viewed from the brake end of the winch.

DISC BRAKE ASSEMBLY PARTS LIST

ITEM NO.	DESCRIPTION OF PART	QTY TOTAL	PART NUMBER	ITEM NO.	DESCRIPTION OF PART	QTY TOTAL	PART NUMBER
320	Disc Brake Assembly *	1	25426	15	Pressure Plate	1	24137
1	Capscrew	8	71264717	• 16	Sprag Clutch ***	1	71044853
2	End Cover **	1	23605	• 17	Spring	12	71053730
• 3	Diaphragm	1	22031	• 18	Gasket	1	71262257
4	Ring	1	22028	19	Support Plate	1	24138
5	Diaphragm Support	1	22027	20	Dowel Pin	1	71126759
6	Housing	1	22026	• 21	Bearing	1	50449
7	Plug	2	71069009	22	Retainer Ring	1	54375
8	Breather	1	71271175	23	Retainer Ring	1	71053748
9	Dowel Pin	3	71126882	25	Brake Shaft	1	25109
• 10	Inner Race ***	1	24038	76	Washer	2	71046981
11	Spacer	2	19007	77	Capscrew	2	71146617
• 12	Outer Race ***	1	22032	78	Clamp	2	71300131
• 13	Friction Plate	5	71126874	79	Valve Exhaust	1	71047898
14	Separator Plate	6	22033	80	Elbow Fitting	1	24141

Sideframe without Drum Brake				Sideframe with Drum Brake			
65	Short Drum (7 in)	1	24901-1	65	Short Drum (7 in)	1	24901-6
	Medium Drum (13-1/2 in)		24901-2		Medium Drum (13-1/2 in)		24901-4
	Long Drum (20 in)		24901-5		Long Drum (20 in)		24901-3
	Extra Long Drum (24 in)		24901-7		Extra Long Drum (24 in)		24901-8
Brake Hose without Drum Brake				Brake Hose with Drum Brake			
75	Short Drum (7 in)	1	25403-36	75	Short Drum (7 in)	1	25403-39
	Medium Drum (13-1/2 in)		25403-42.5		Medium Drum (13-1/2 in)		25403-45.5
	Long Drum (20 in)		25403-49		Long Drum (20 in)		25403-52
	Extra Long Drum (24 in)		25403-53		Extra Long Drum (24 in)		25403-56

- Recommended spare.
- * Disc Brake Assembly includes items 1 through 23.
- ** As viewed from the brake end, the air line attaches to the brake cover on either the left hand side, or from the bottom on standard winches and on the right hand side on winches supplied with the optional Open Frame (Face) configuration. On winches with the optional Open Frame (Face) configuration, install the end cover (item 2) rotated 180° from view shown.
- *** When replacing Sprag Clutch (item 16) also replace Inner Race (item 10) and Outer Race (item 12).

AUTOMATIC DRUM BRAKE ASSEMBLY DRAWING AND PARTS LIST

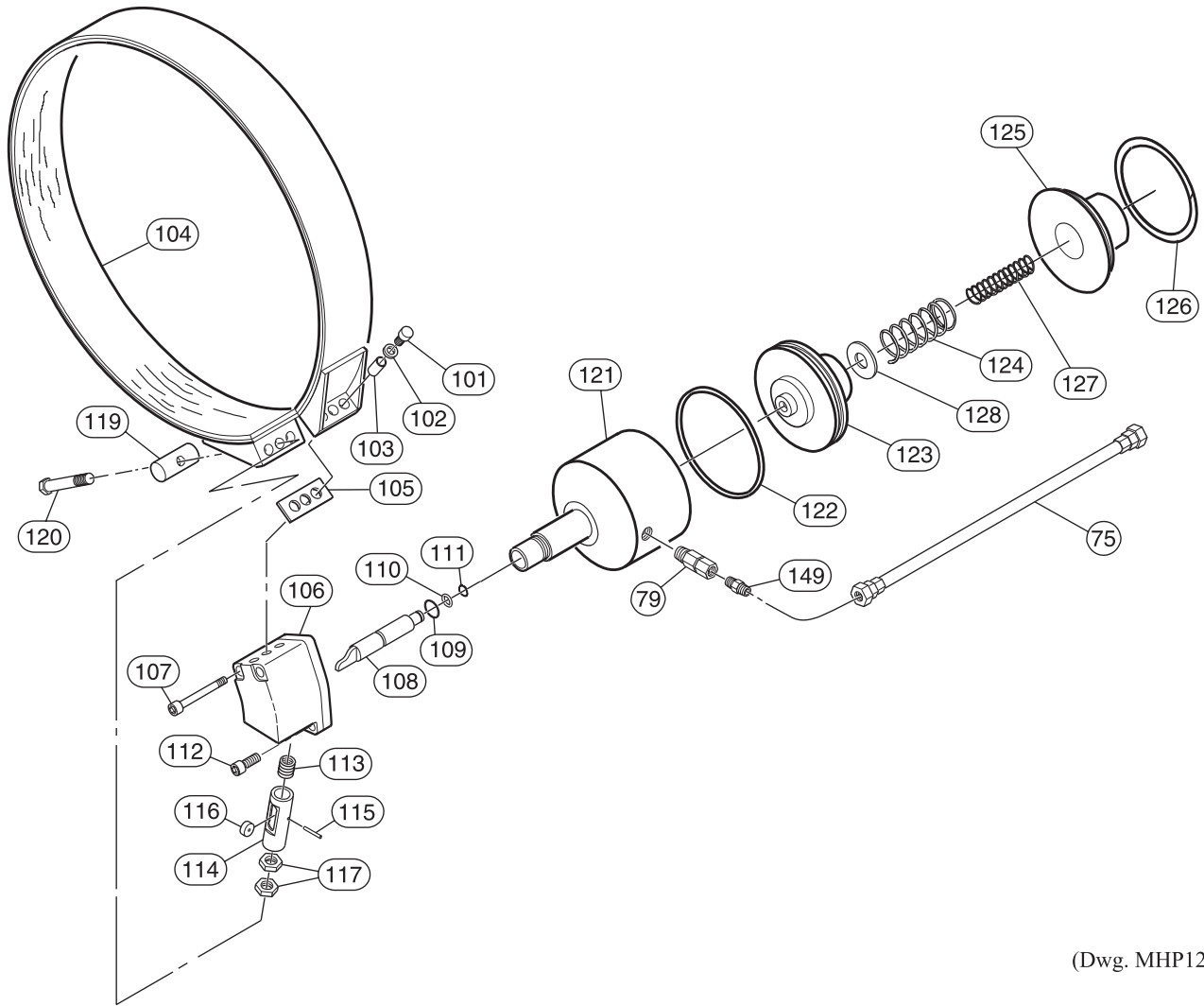

(Dwg. MHP1281)

ITEM NO.	DESCRIPTION OF PART	QTY TOTAL	PART NUMBER	ITEM NO.	DESCRIPTION OF PART	QTY TOTAL	PART NUMBER
75	Hose Assembly	1	24403-39	114	Plunger	1	23886
79	Valve, Exhaust	1	71047898	115	Pin, Dowel	1	71144968
100	Brake Assembly *	1	25155	116	Roller	1	23883
101	Capscrew	3	71264808	117	Jam Nut	2	71267413
102	Spacer	3	21899	119	Pivot Bar	1	23755
103	Spacer Tube	3	21891	120	Capscrew	1	71267405
104	Band Assembly	1	25144	121	Cylinder	1	26138
105	Spacer	1	23029	• 122	'O' Ring	1	52536
106	Brake Bracket	1	22984	123	Piston	1	25534
107	Capscrew	2	71298921	124	Spring	1	71299721
108	Cylinder Rod	1	23885	125	Cover	1	25392
• 109	'O' Ring	1	71049423	126	Retainer Ring	1	71126668
• 110	'O' Ring	1	52662	127	Spring	1	71299713
111	Retainer Ring	1	54136	128	Washer	1	71145080
112	Capscrew	2	71298939	149	Fitting, Nipple	1	52092
113	Spring	1	71126643				

• Recommended spare. * Brake assembly (100) consists of items 75, 79, and 101 through 128.

MANUAL DRUM BAND BRAKE ASSEMBLY DRAWING AND PARTS LIST

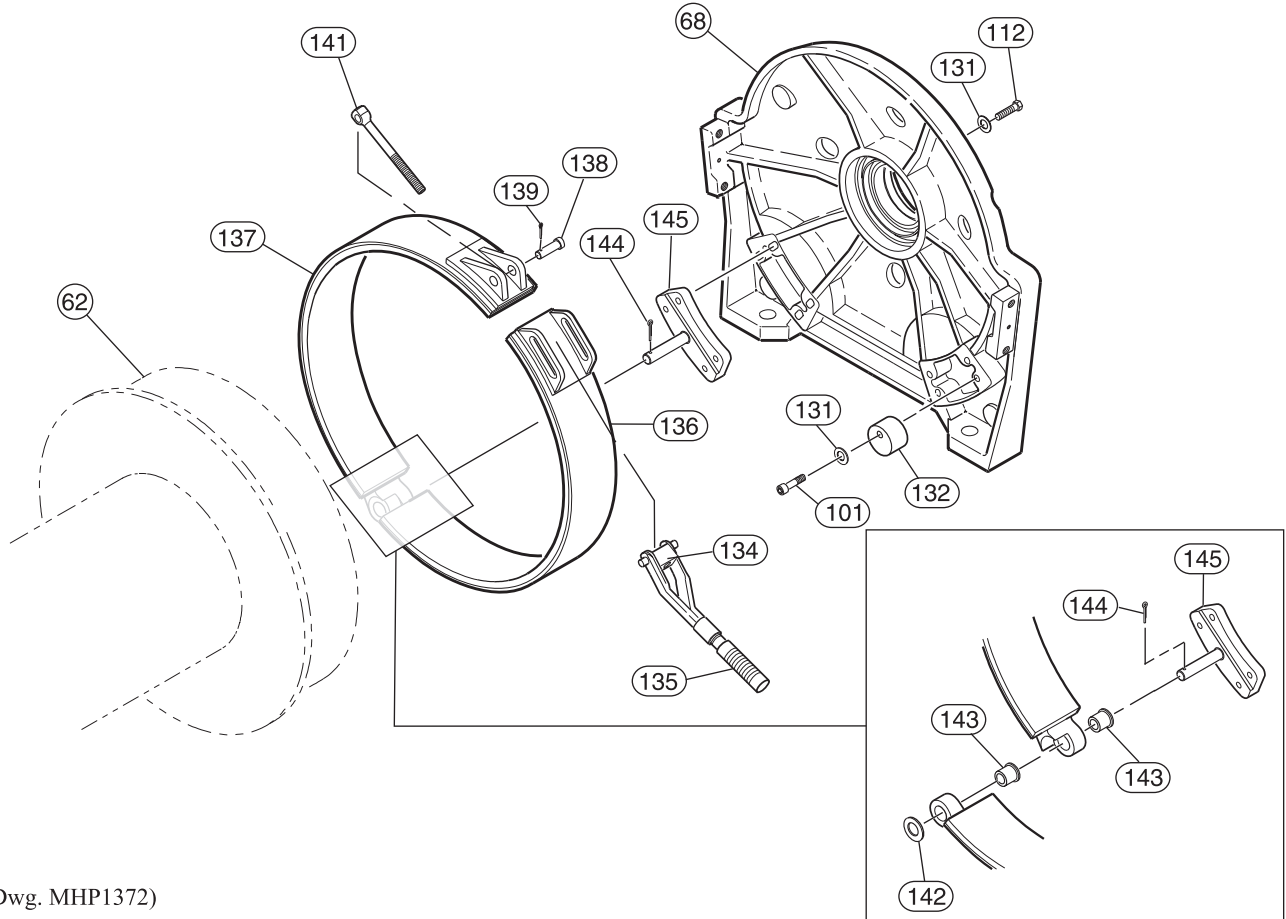

(Dwg. MHP1372)

ITEM NO.	DESCRIPTION OF PART	QTY TOTAL	PART NUMBER	ITEM NO.	DESCRIPTION OF PART	QTY TOTAL	PART NUMBER
68	Upright, Motor End	1	24893-1	137	Front Brake Pad *	1	26305
101	Capscrew	1	71331847	138	Pin	1	4303-S
112	Capscrew	4	71331839	139	Cotter Pin	1	51937
131	Washer	5	71274807	141	Brake Link Stud	1	2448
132	Cam Stop	1	26304	142	Washer	1	71331771
134	Pivot Nut	1	2445	143	Bushing	2	71331730
135	Brake Handle	1	2329	144	Cotter Pin	1	51021
136	Rear Brake Pad *	1	26306	145	Adapter Plate	1	26136

Drum (with Drum Band Brake)

62	Short Drum (7 in.)	1	25316	62	Long Drum (20 in.)	1	25351
	Medium Drum (13-1/2 in.)		25353		Extra Long Drum (24 in.)		25751

● Recommended spare.

* Items (136) and (137) must be purchased as an assembly. Order Brake Band Assembly to replace Rear and Front Brake Pads.

Brake Band Assembly	1	26320
---------------------	---	-------

CONTROL VALVE ASSEMBLY PARTS DRAWING

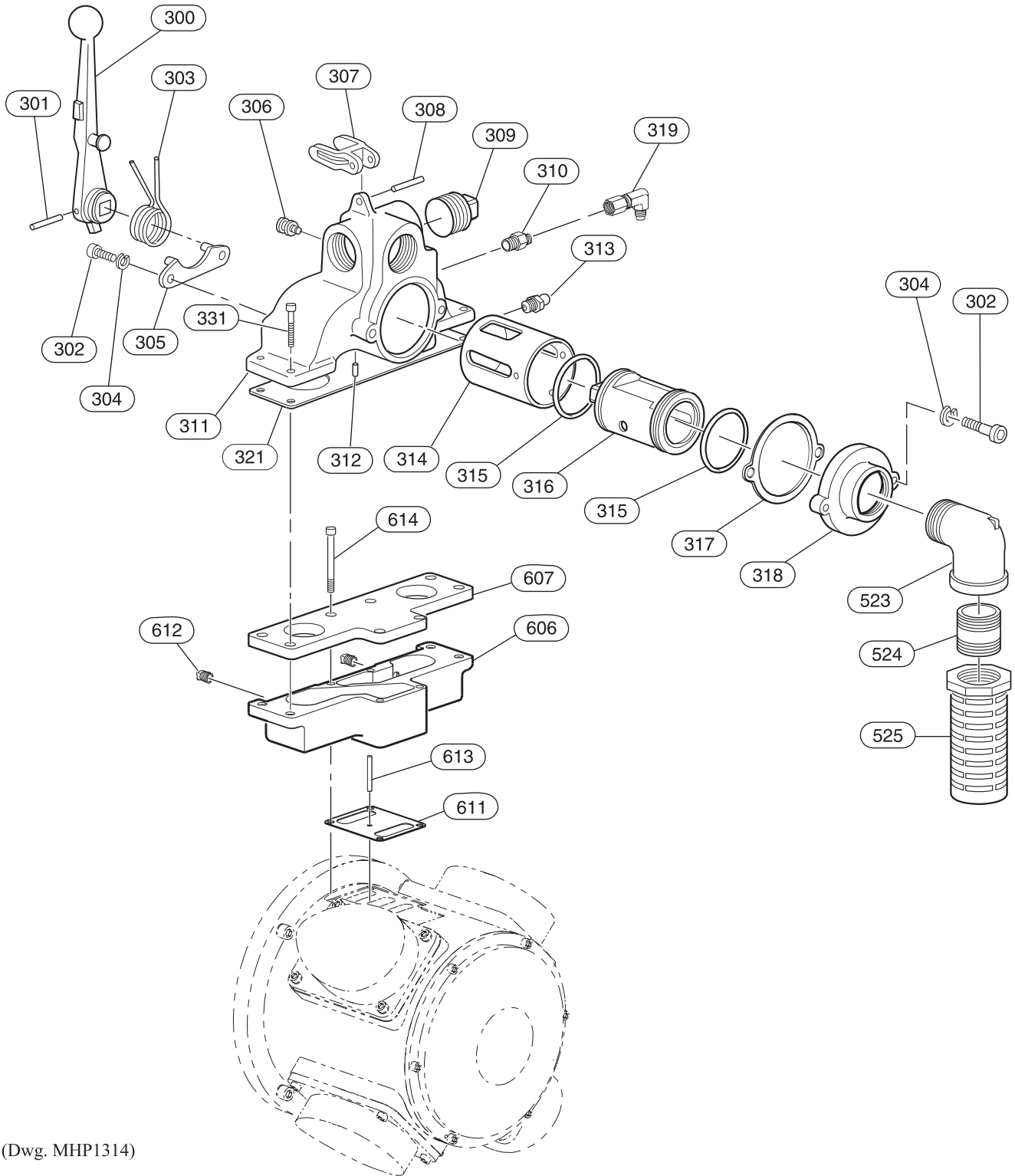

(Dwg. MHP1314)

CONTROL VALVE ASSEMBLY PARTS LIST

ITEM NO.	DESCRIPTION OF PART	QTY TOTAL	PART NUMBER	ITEM NO.	DESCRIPTION OF PART	QTY TOTAL	PART NUMBER
260	Valve Assembly *	1	26126	• 315	Seal Ring	2	K5B-606
300	Handle	1	K5B-556P	316	Valve Body	1	26125
301	Roll Pin	1	K5B-1115	• 317	Gasket	1	K5B-275
302	Capscrew	4	71292064	318	Flange	1	KK5B-276SP
• 303	Spring	1	K5B-412	319	Fitting, Elbow Swivel	1	71328561
304	Lockwasher	4	51581	• 321	Gasket	1	K5B-547
305	Valve Body Retainer	1	K5B-1110AP	331	Capscrew	4	71325039
306	Spring Retaining Stud	1	K5B-553	523	Fitting, Elbow	1	71273676
307	Latch	1	K5B-869AP	524	Fitting, Nipple	1	71057483
308	Roll Pin	1	HLK-20	525	Muffler	1	52472
309	Pipe Plug	2	71263297	606	Manifold ***	1	26128
310	Fitting, Bushing	1	51814	607	Cover, Manifold ***	1	26130
311	Valve Housing **	1	26062	• 611	Gasket	1	26129
312	Roll Pin	1	71326102	612	Pipe Plug	2	54246
313	Grease Fitting	1	53095	613	Dowel Pin	1	71326508
314	Valve Bushing **	1	26040	614	Capscrew	4	71326441

• Recommended spare.

* Valve Assembly (260) includes items 300 through 309 and 311 through 318.

** Valve Housing (311) and Valve Bushing (314) are a matched set. Replace both at the same time.

*** Manifold (606) and Cover (607) are bonded together and should not be separated.

REMOTE PENDANT AND CONTROL VALVE ASSEMBLY PARTS DRAWING

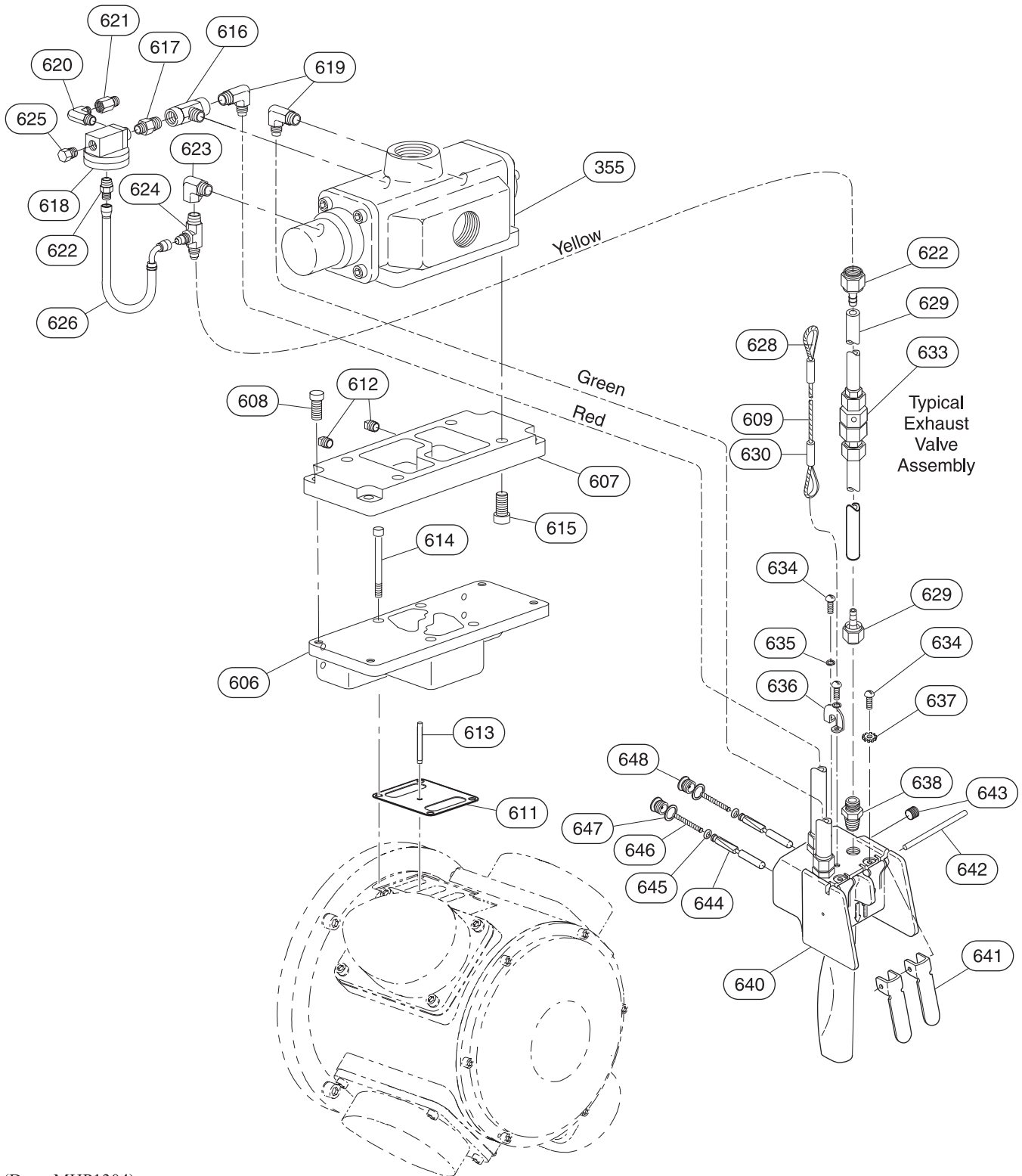

(Dwg. MHP1304)

REMOTE PENDANT AND CONTROL VALVE ASSEMBLY PARTS LIST

ITEM NO.	DESCRIPTION OF PART	QTY. TOTAL	PART NUMBER	ITEM NO.	DESCRIPTION OF PART	QTY. TOTAL	PART NUMBER
149	Fitting, Nipple	1	52092	628	Clamping Thimble	2	MLK-602
355	Valve Assembly	1	26170	632	Hose (specify length)	3	50923
606	Manifold	1	26168	630	Clamping Sleeve (see note 1)	2	MLK-521
607	Cover, Manifold	1	26169				
609	Strain Relief Cable (specify length)	1	BWR3A	633	Quick Exhaust Valve Assembly	*	20417
614	Capscrew	4	71329528	634	Screw	4	HRE20A-68
615	Capscrew	4	71327274	635	Lockwasher	1 pack	H54U-352-10
616	Fitting, Tee	1	K6U-926	636	Strain Relief Support	1	MLK-450
617	Fitting, Nipple	1	54679	637	Lockwasher	2	D02-138
618	Valve	1	54672	638	Fitting, Nipple	3	MLK-165
619	Fitting, Elbow	2	52182	639	Pendant Kit*	1	MLK-K269C
620	Fitting, Elbow	1	71063473	640	Pendant Assembly **	1	MLK-A269C
621	Fitting, Connector	1	71110894	641	Throttle Lever	2	MLK-273
622	Barbed Swivel Fitting	6	51029	642	Throttle Lever Pin	1	DLC-120A
623	Fitting, Elbow	1	71034714	643	Plug	1	502-95
624	Fitting, Tee	1	52181	644	Pendant Throttle Valve	2	MLK-K264B
625	Breather	1	51559	• 645	Valve Seal	2	R000BR1C-283
626	Hose Assembly	1	17073-6	• 646	Valve Spring	2	MLK-51A
627	Strain Relief Assembly (Includes items 628 through 630)	1	MLK-LWR3A	• 647	Valve Cap Gasket	2	MLK-504
				648	Valve Cap	2	MLK-K266A
				649	Hose Tie (3 for standard hose; 2 additional each 5 ft hose) ***		HRE20A-283

• Recommended Spare

* Quantity of 2 required when hose length exceeds 20 ft (6 m); quantity of 4 required when hose length exceeds 50 ft (16 m).

** Includes 629, 634 through 638 and 641 through 648.

*** Not shown on drawing.

Notes: 1. A crimping tool (Nicropress® Tool with groove size G) is required to install the clamping sleeves (630).

CONTROL AIR VALVE ASSEMBLY DRAWING AND PARTS LIST

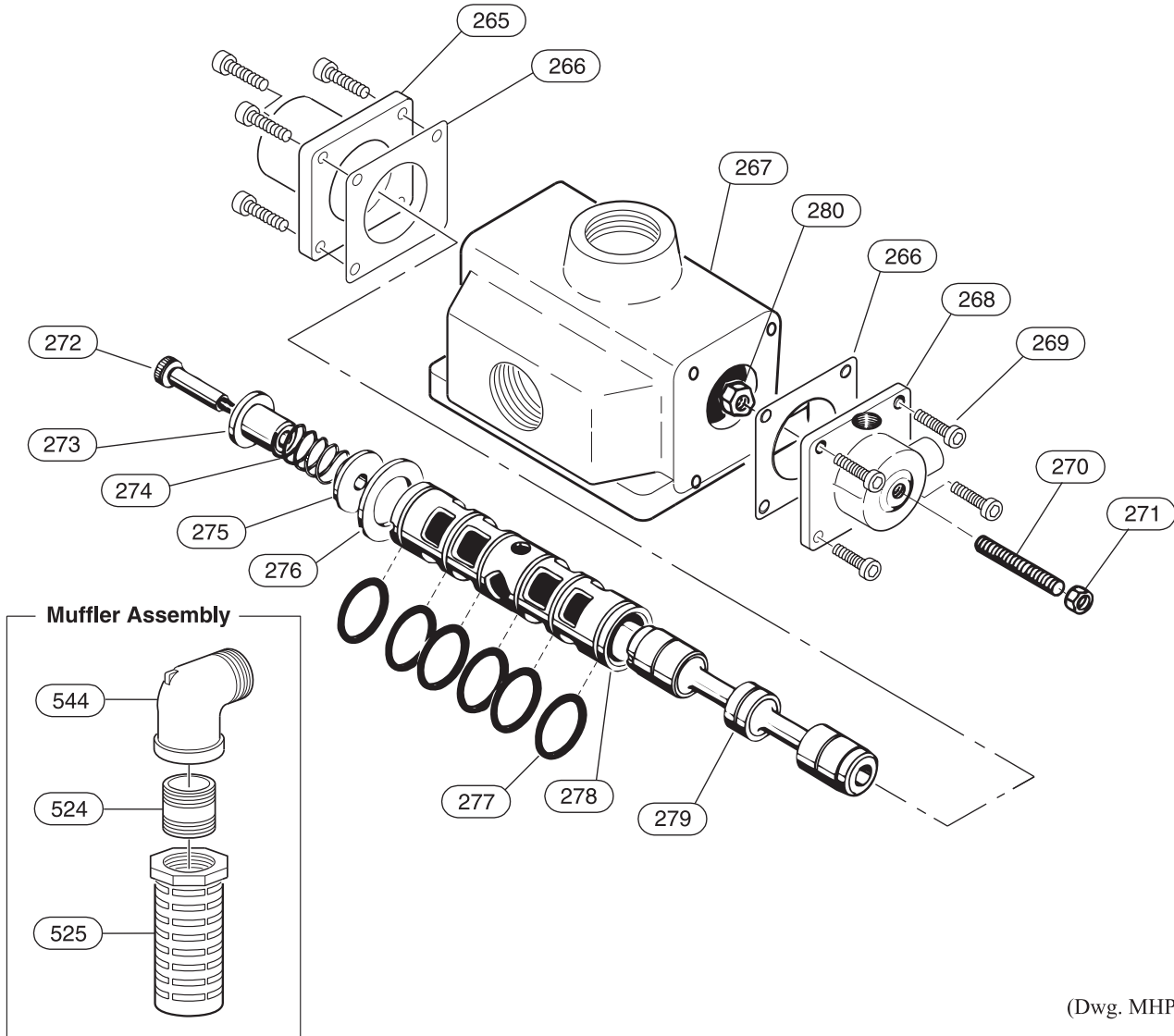

(Dwg. MHP1305)

ITEM NO.	DESCRIPTION OF PART	QTY TOTAL	PART NUMBER	ITEM NO.	DESCRIPTION OF PART	QTY TOTAL	PART NUMBER
355	Valve Assembly *	1	26170	274	Spring	1	52240
265	End Cap	1	52241	275	Washer	1	52239
• 266	Gasket	2	52457	276	Spacer	1	52238
267	Valve Body	1	**	• 277	'O' Ring	6	52456
268	End Cap (Inlet Side)	1	11778	278	Valve Sleeve	1	**
269	Capscrew	8	71327738	279	Valve Spool	1	**
270	Adjusting Screw	1	71327720	280	Nut	1	50176
271	Nut	1	71069132	524	Fitting, Nipple	1	71057483
272	Shoulder Screw	1	54710	525	Muffler	1	52472
273	Guide	1	52233	544	Fitting, Elbow	1	71330112

• Recommended spare.

* Valve Assembly (355) includes items 265 through 280.

** Valve Body (267), Valve Sleeve (278) and Valve Spool (279) are not sold separately. To replace these items order Valve Assembly (355).

REMOTE PENDANT WITH EMERGENCY STOP ASSEMBLY DRAWING AND PARTS LIST

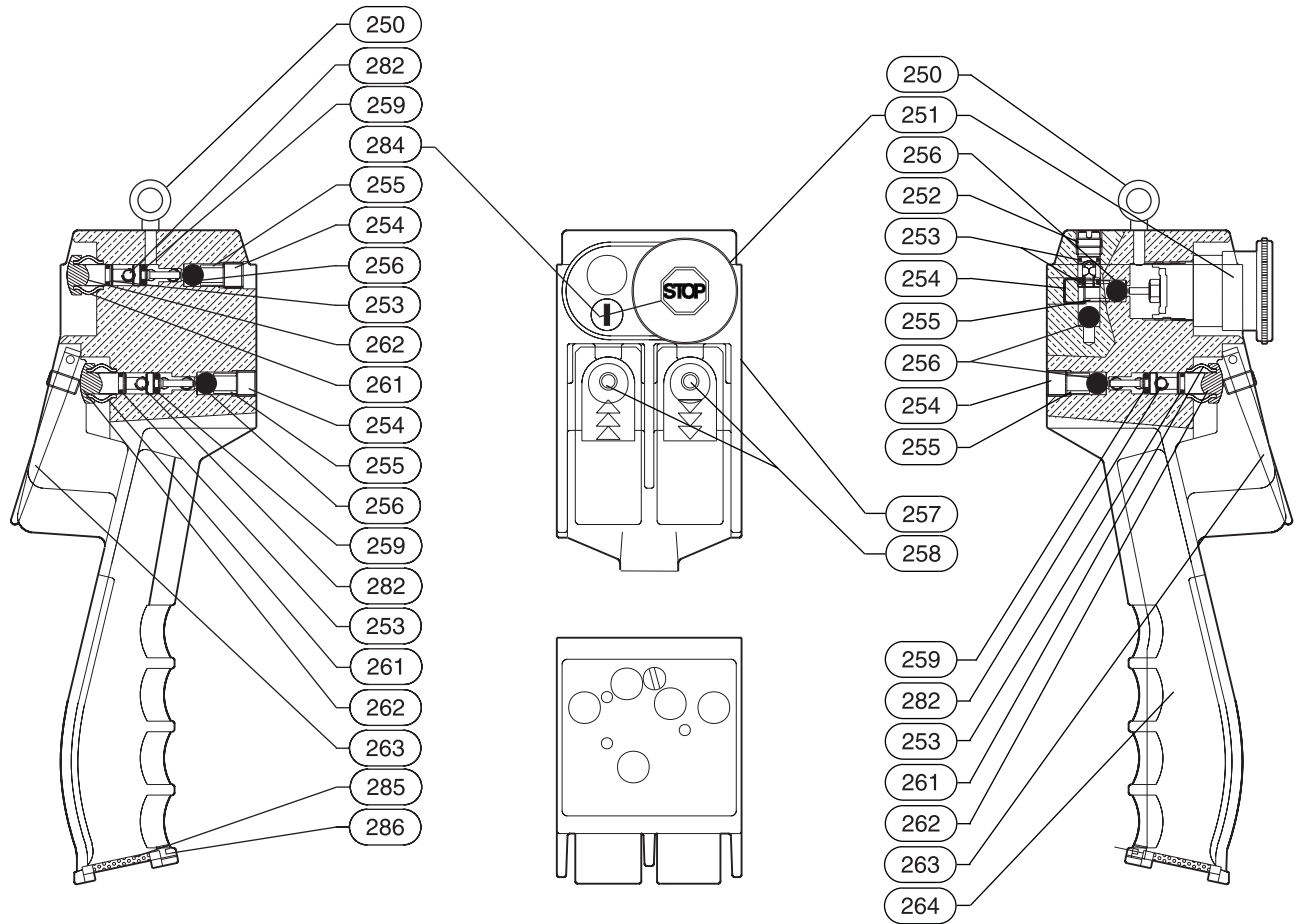

(Dwg. MHP1376)

ITEM NO.	DESCRIPTION OF PART	QTY TOTAL	PART NUMBER	ITEM NO.	DESCRIPTION OF PART	QTY TOTAL	PART NUMBER
640	Pendant Assembly	1	3579-0072	● 259	'O' Ring	3	58235329
250	Lifting Eye	1	64222332	261	Protector	3	95790107
251	Emergency Stop Valve	1	95790108	262	Valve	3	95790104
252	Obstructor	3	95790106	263	Lever	2	95790110
● 253	'O' Ring	5	58209229	264	Pendant Handle	1	95790113
254	Plug	4	65107741	282	Screw	3	42008207
255	Spring	4	69128541	284	Label Kit	1	95790111
256	Ball	5	69401625	285	Exhaust Washer	1	95790114
257	Pin	1	95790040	286	Screw	1	42008107
258	Screw	2	42006207				

● Recommended spare.

EMERGENCY STOP AND OVERLOAD ASSEMBLY PARTS DRAWING

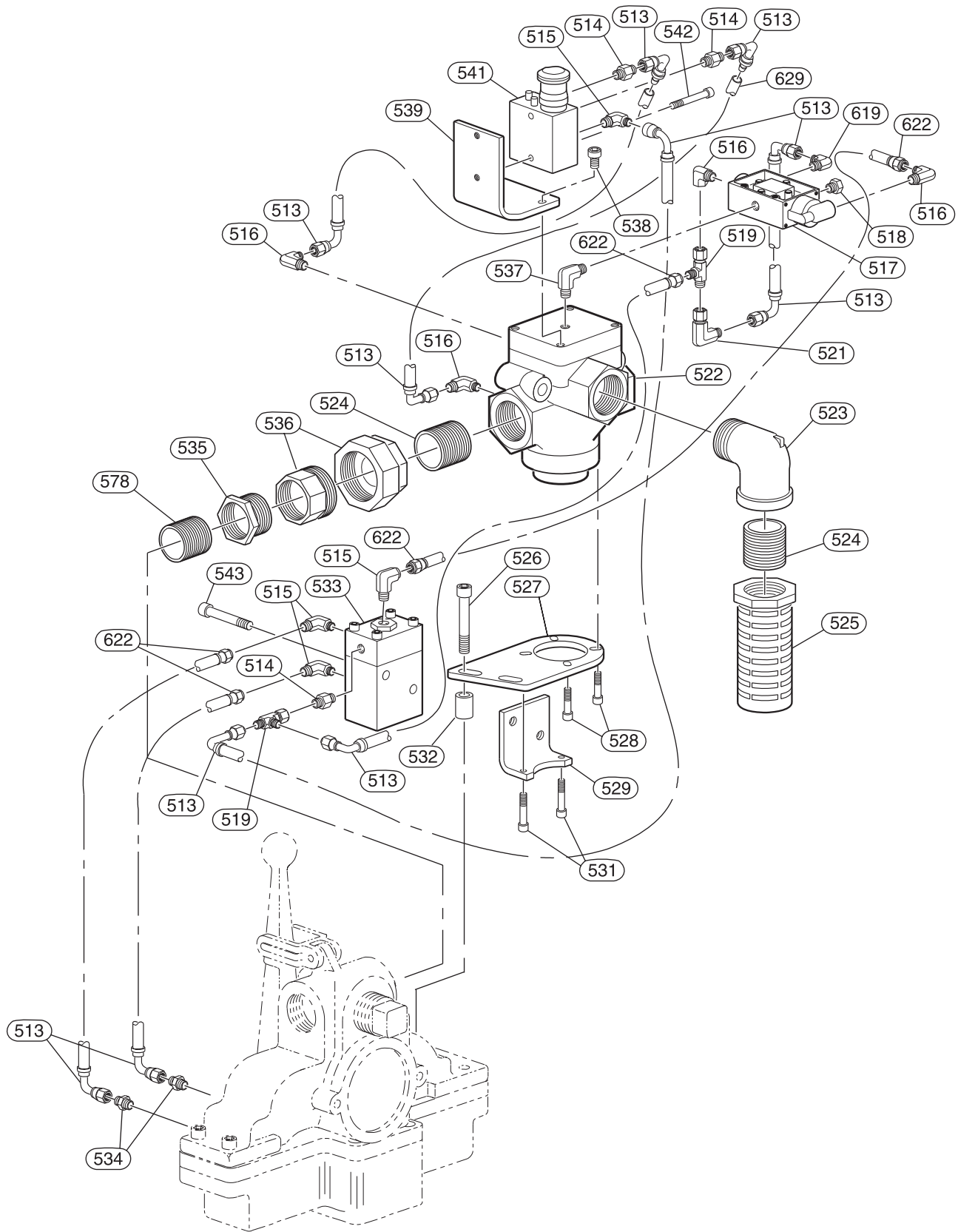

(Dwg. MHP1331)

EMERGENCY STOP AND OVERLOAD ASSEMBLY PARTS LIST

ITEM NO.	DESCRIPTION OF PART	QTY TOTAL	PART NUMBER	ITEM NO.	DESCRIPTION OF PART	QTY TOTAL	PART NUMBER
513	Fitting, Elbow	11	52179	531	Capscrew	2	71327324
514	Fitting, Nipple	3	71078158	532	Spacer	2	14998-7B
515	Fitting, Elbow	4	71327316	533	Delta 'P' Valve	1	3636-0002
516	Fitting, Elbow	4	51281	534	Fitting, Nipple	2	71048268
517	Shuttle Valve	1	71269036	535	Fitting, Bushing	1	51706
518	Breather	1	50595	536	Fitting, Union	1	71149355
519	Fitting, Tee	2	71067789	537	Fitting, Elbow	1	54273
521	Fitting, Elbow	1	71327399	538	Capscrew	2	71327357
522	Shut Off Valve	1	25541	539	Bracket	1	26147
523	Fitting, Elbow	1	71273676	541	Emergency Stop Valve	1	3579-0066
524	Fitting, Nipple	2	71057483	542	Capscrew	2	71327340
525	Muffler	1	52472	543	Capscrew	2	54240
526	Capscrew	2	54184	578	Fitting, Nipple	1	51704
527	Bracket	1	26166	619	Fitting, Elbow	1	52182
528	Capscrew	2	71329650	622	Barbed Swivel Fitting	5	51029
529	Bracket	1	26148	629	Hose Bulk (specify length)	6	50923

REMOTE EMERGENCY STOP AND OVERLOAD ASSEMBLY PARTS DRAWING

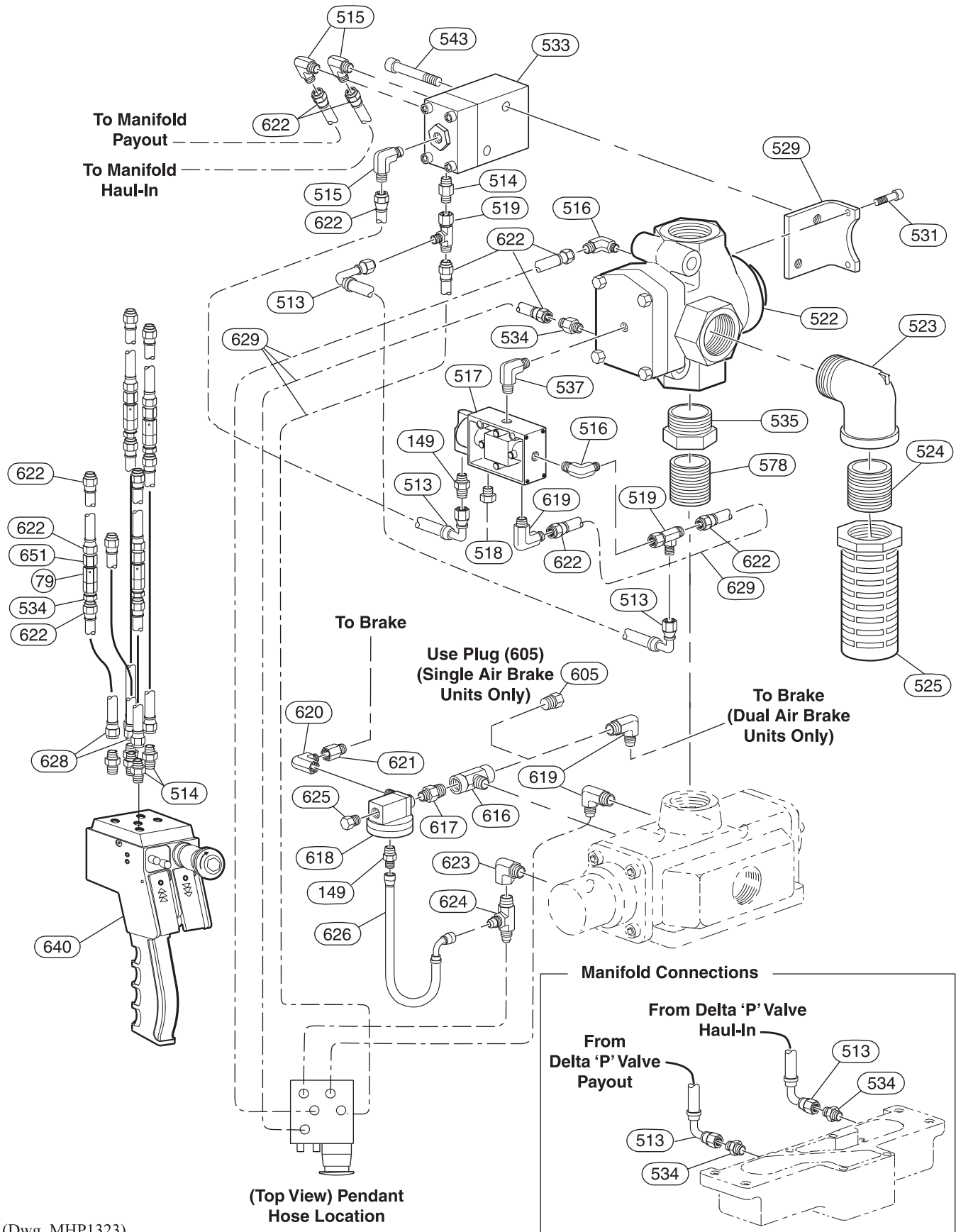

(Dwg. MHP1323)

REMOTE EMERGENCY STOP AND OVERLOAD ASSEMBLY PARTS LIST

ITEM NO.	DESCRIPTION OF PART	QTY TOTAL	PART NUMBER	ITEM NO.	DESCRIPTION OF PART	QTY TOTAL	PART NUMBER
79	Valve, Exhaust	4	71047898	537	Fitting, Elbow	1	54273
149	Fitting, Nipple	2	52092	543	Capscrew	2	54240
513	Fitting, Elbow	5	52179	578	Fitting, Nipple	1	51704
514	Fitting, Nipple	6	71078158	605	Plug	1	50860
515	Fitting, Elbow	3	71327316	616	Fitting, Tee	1	K6U-926
516	Fitting, Elbow	2	51281	617	Fitting, Nipple	1	54679
517	Shuttle Valve	1	71269036	618	Valve	1	54672
518	Breather	1	50595	619	Fitting, Elbow	3	52182
519	Fitting, Tee	2	71067789	620	Fitting, Elbow	1	71063473
522	Shut Off Valve	1	25541	621	Fitting, Connector	1	71110894
523	Fitting, Elbow	1	71273676	622	Barbed Swivel Fitting	5	51029
524	Fitting, Nipple	1	71057483	623	Fitting, Elbow	1	71034714
525	Muffler	1	52472	624	Fitting, Tee	1	52181
529	Bracket	1	26148	625	Breather	1	51559
531	Capscrew	2	71327324	626	Hose Assembly	1	17073-6
533	Delta 'P' Valve	1	3636-0002	629	Hose Bulk (specify length)	8	50923
534	Fitting, Nipple	7	71048268	640	Pendant Assembly	1	3579-0072
535	Fitting, Bushing	1	51706	651	Fitting, Nipple	4	71048284

OPEN FRAME (FACE) ASSEMBLY DRAWING AND PARTS LIST

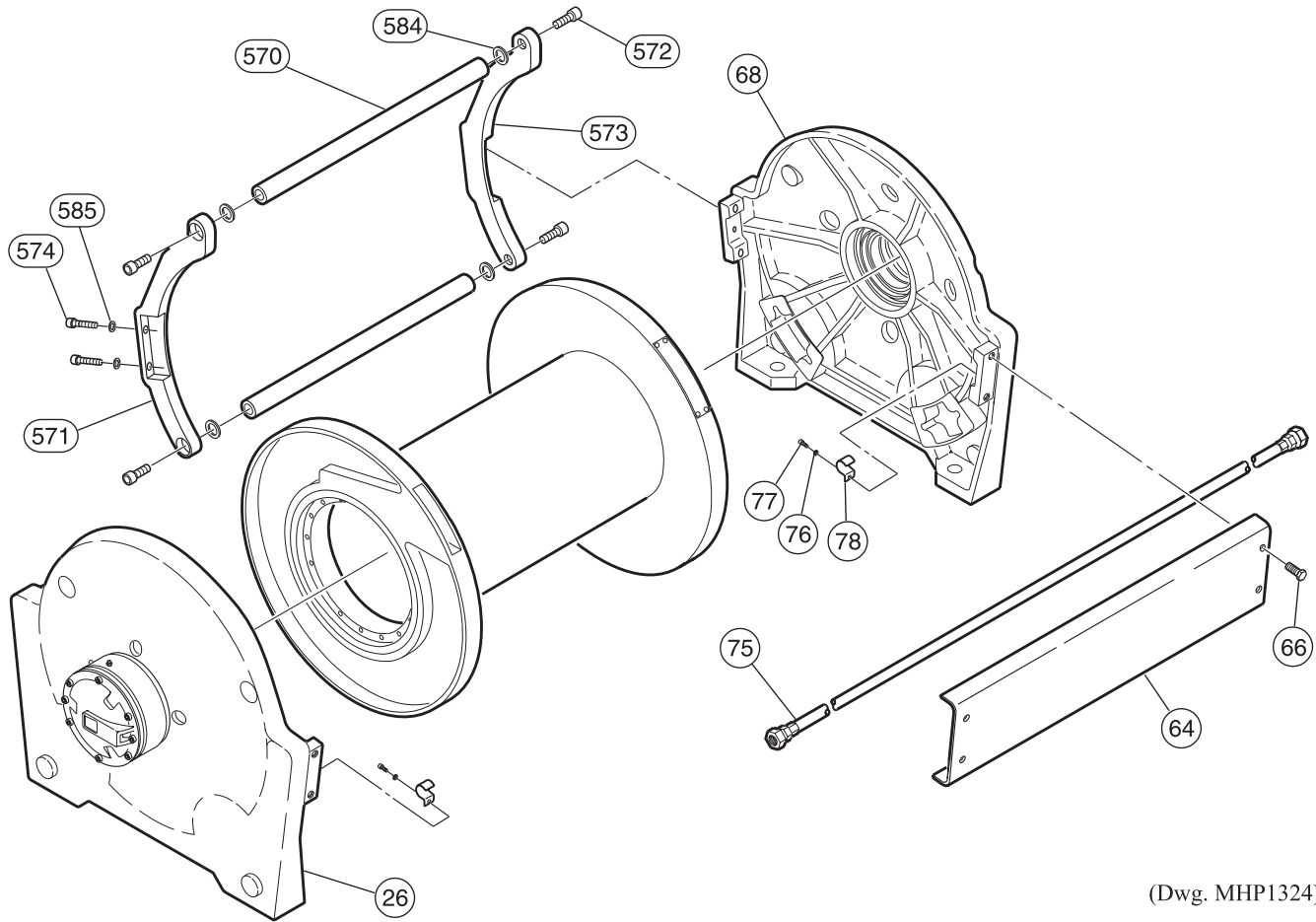

(Dwg. MHP1324)

ITEM NO.	DESCRIPTION OF PART	QTY TOTAL	PART NUMBER	ITEM NO.	DESCRIPTION OF PART	QTY TOTAL	PART NUMBER
26	Upright, Outboard End	1	24871	571	Sideframe, Outboard End	1	25668
66	Capscrew	4	71264683	572	Capscrew	4	71306450
68	Upright, Motor End	1	24893	573	Sideframe, Motor End	1	25670
76	Washer	2	71046981	574	Capscrew	4	71306435
77	Capscrew	2	71146617	584	Washer	As Reqd.	52915
78	Clamp	2	71300131	585	Washer	4	71274807
Sideframe (Rear) without Drum Brake				Sideframe (Rear) with Drum Brake			
64	Short Drum (7 in.)	1	24901-1	64	Short Drum (7 in.)	1	25424-1
	Medium Drum (13-1/2 in.)		24901-2		Medium Drum (13-1/2 in.)		25424-2
	Long Drum (20 in.)		24901-5		Long Drum (20 in.)		25424-3
	Extra Long Drum (24 in.)		24901-7		Extra Long Drum (24 in.)		25424-4
Brake Hose without Drum Brake				Brake Hose with Drum Brake			
75	Short Drum (7 in.)	1	25403-36	75	Short Drum (7 in.)	1	25403-39
	Medium Drum (13-1/2 in.)		25403-42.5		Medium Drum (13-1/2 in.)		25403-45.5
	Long Drum (20 in.)		25403-49		Long Drum (20 in.)		25403-52
	Extra Long Drum (24 in.)		25403-53		Extra Long Drum (24 in.)		25403-56
Bar without Drum Brake				Bar with Drum Brake			
570	Short Drum (7 in.)	2	25671-1	570	Short Drum (7 in.)	2	25671-4
	Medium Drum (13-1/2 in.)		25671-2		Medium Drum (13-1/2 in.)		25671-5
	Long Drum (20 in.)		25671-3		Long Drum (20 in.)		25671-6
	Extra Long Drum (24 in.)		25671-7		Extra Long Drum (24 in.)		25671-8

DRUM GUARD ASSEMBLY DRAWING AND PARTS LIST

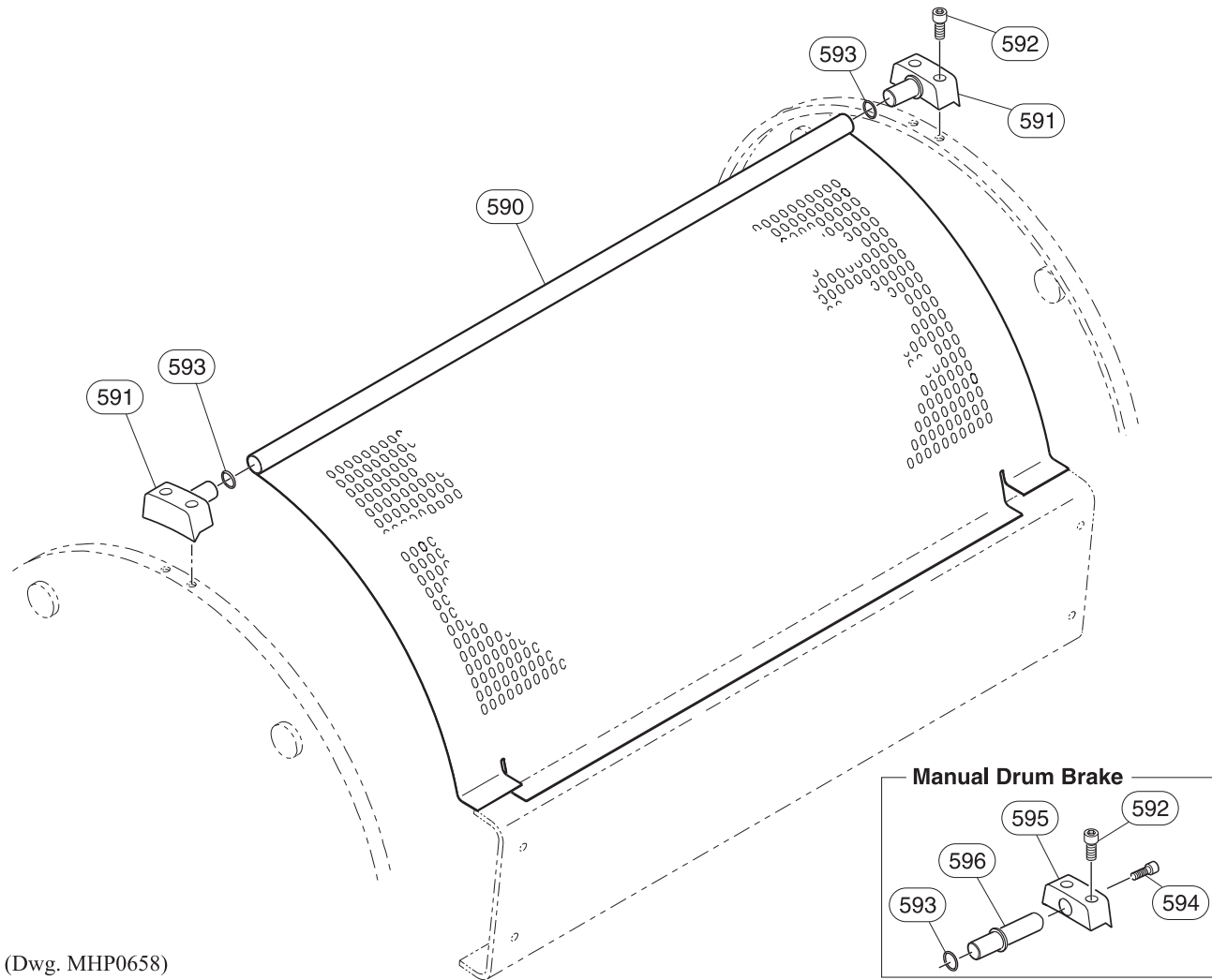

(Dwg. MHP0658)

ITEM NO.	DESCRIPTION OF PART	QTY TOTAL	PART NUMBER	
			With Drum Brake	Without Drum Brake
590	Short Drum (7 in)	1	25298	25299
	Medium Drum (13-1/2 in)		25255	25300
	Long Drum (20 in)		25301	25302
	Extra Long Drum (24 in)		26257	26258
591	Bracket *	See ()	23608 (2)	23608 (1)
592	Capscrew	4	71261739	
593	Washer	As Req'd.	71296800	
594	Capscrew	1	71328389	---
595	Bracket *	1	26311	---
596	Extension	1	26312	---

Drum Guard Assemblies (includes Items 590 through 593)

Drum Guard Assembly without Drum Brake			Drum Guard Assembly with Automatic Drum Brake		
Short Drum (7 in)	1	25296	Short Drum (7 in)	1	25294
Medium Drum (13-1/2 in)		25256	Medium Drum (13-1/2 in)		25295
Long Drum (20 in)		25293	Long Drum (20 in)		25297
Extra Long Drum (24 in)		25737	Extra Long Drum (24 in)		25738

Drum Guard Assembly with Manual Drum Brake (includes Items 590 through 596)

Short Drum (7 in)	1	26317-1	Long Drum (20 in)	1	26317-3
Medium Drum (13-1/2 in)		26317-2	Extra Long Drum (24 in)		26317-4

FREE SPOOL ASSEMBLY PARTS DRAWING AND PARTS LIST

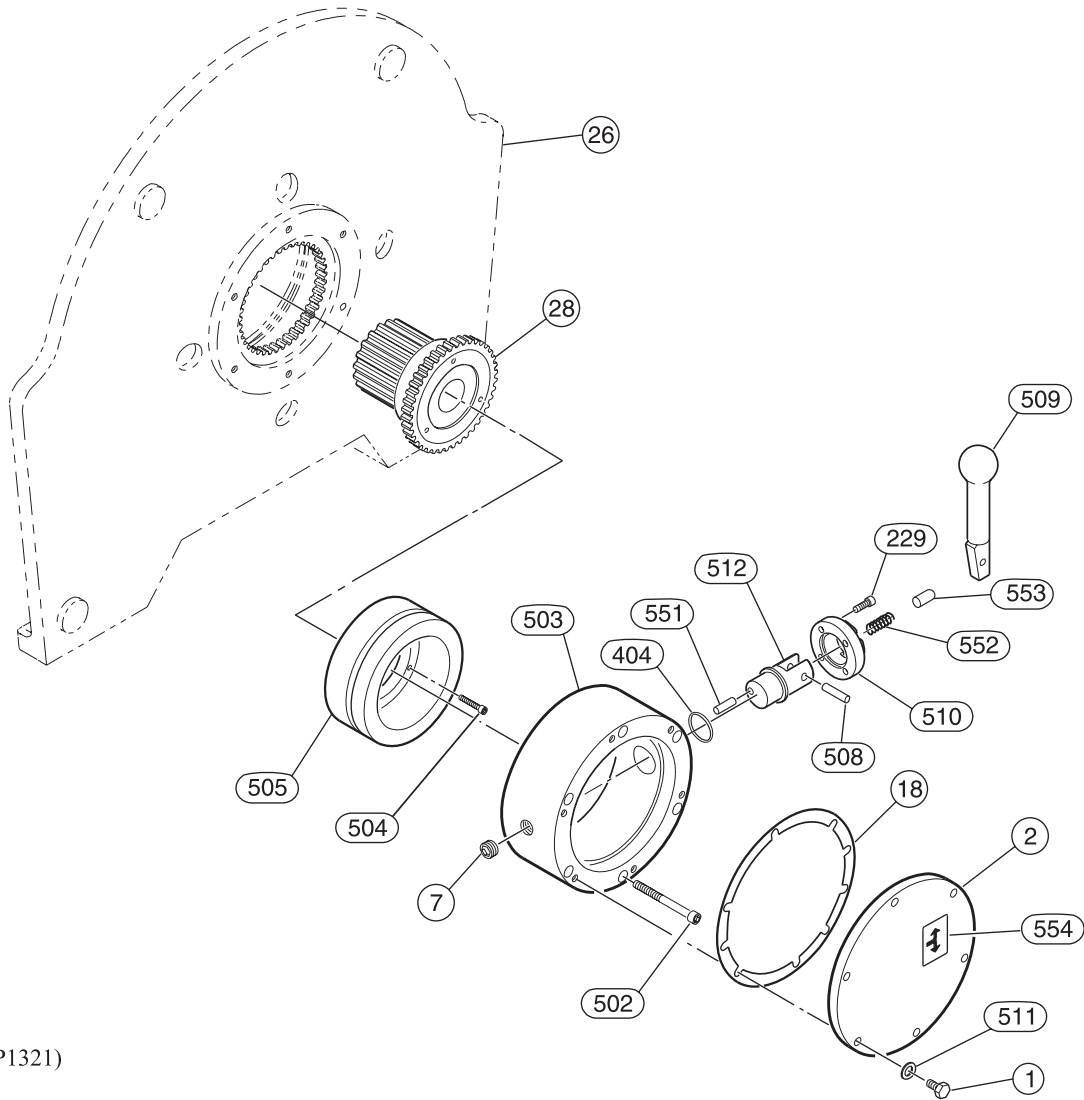

(Dwg. MHP1321)

ITEM NO.	DESCRIPTION OF PART	QTY TOTAL	PART NUMBER	ITEM NO.	DESCRIPTION OF PART	QTY TOTAL	PART NUMBER
1	Capscrew	6	71266613	505	Shaft Support	1	22257
2	End Cover	1	21732	506	Shifter Assembly **	1	26172
7	Plug	1	71069009	508	Dowel Pin	1	71328173
• 18	Gasket	1	71262257	509	Handle	1	HU-565P
26	Upright, Outboard End	1	24871	510	Detent Plate	1	26182
28	Output Shaft	1	24817	511	Washer	1	71303408
229	Capscrew	4	71307284	512	Shifter	1	26173
• 404	'O' Ring	1	71137988	551	Dowel Pin	1	71053722
500	Free Spool Assembly *	1	26183	552	Spring	1	71328181
502	Capscrew	6	71138275	553	Latch	1	HU-566
503	Housing	1	26174	554	Instruction Label	1	71328793
504	Capscrew	3	71138267				

• Recommended spare.

* Free Spool Assembly (item 500) includes items 1, 2, 7, 18, 404 and 502 through 506, 511 and 554.

** Shifter Assembly (item 506) includes items 229, 508 through 510, 512 and 551 through 553.

AIR PREPARATION ASSEMBLY DRAWING AND PARTS LIST

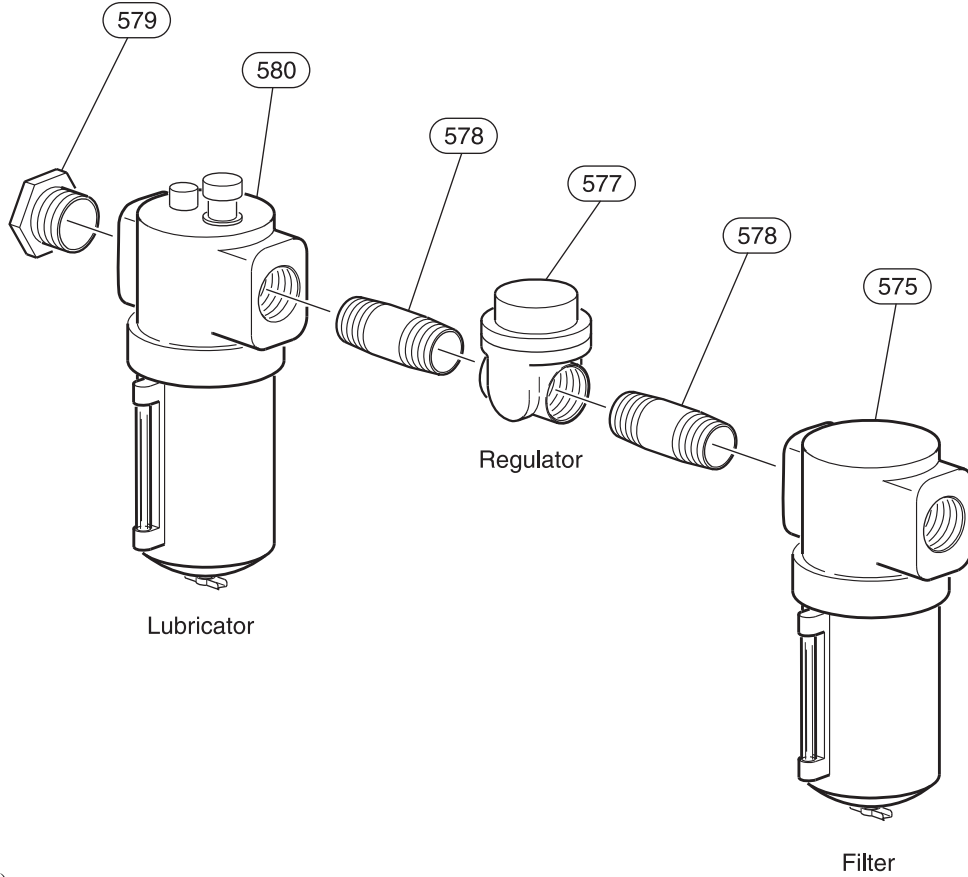

(Dwg. MHP0223)

ITEM NO.	DESCRIPTION OF PART	QUANTITY TOTAL	PART NUMBER
575	Filter	1	71323935
577	Regulator	1	R40-0B-G00
578	Fitting, Nipple	3	51704
579	Pipe Bushing	2	Contact factory
580	Lubricator	1	71323927
581	Liquidator 1-1/2 inch NPT (not shown on drawing)	1	8834-WI-000
582	Pipeline Strainer (not shown on drawing)	1	K4U-A267AT

* Air preparation components for 1-1/4 inch NPT system unless noted otherwise. Items 578 and 579 depend on required size for customer application.

ACCESSORIES AND KITS

DESCRIPTION OF ACCESSORY	QTY TOTAL	PART NUMBER	DESCRIPTION OF ACCESSORY	QTY TOTAL	PART NUMBER
Thermoplastic Powder	4 ounce	71308902	Infra-red Thermometer	1 ea.	71308878
Propane Torch	1 each	71308886	Yellow Touch-Up Paint	1 can	FAP-237Y
Heat Gun	1 each	71308894	Lubricant	16 fl. oz.	LUBRI-LINK-GREEN
Muffler	1 *	52472			

* Quantity of two mufflers required for winches with '-E' Option.

WINCH LABEL/TAG LOCATION DRAWING

Motor End View

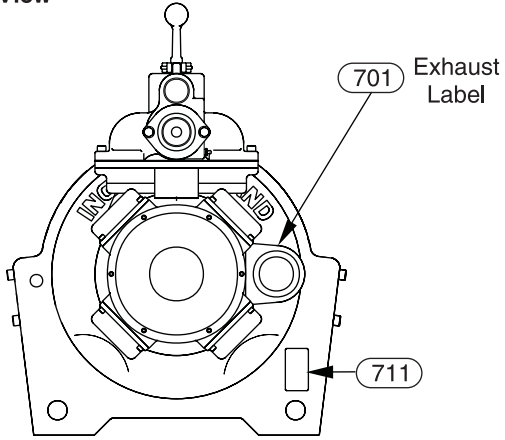

Disc Brake End View

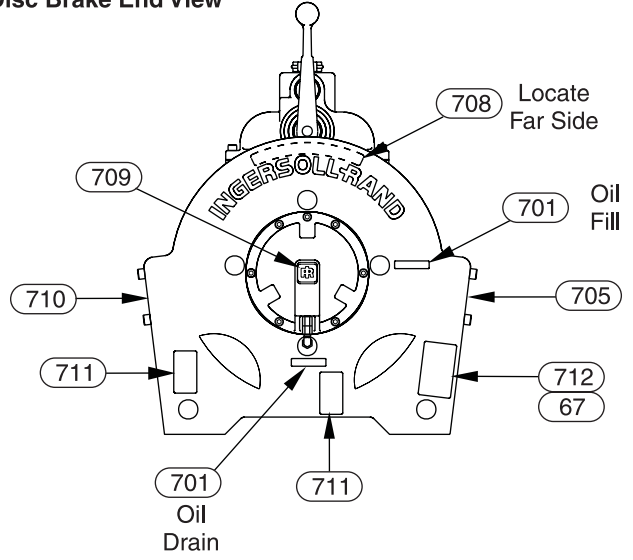

Side View (Rear)

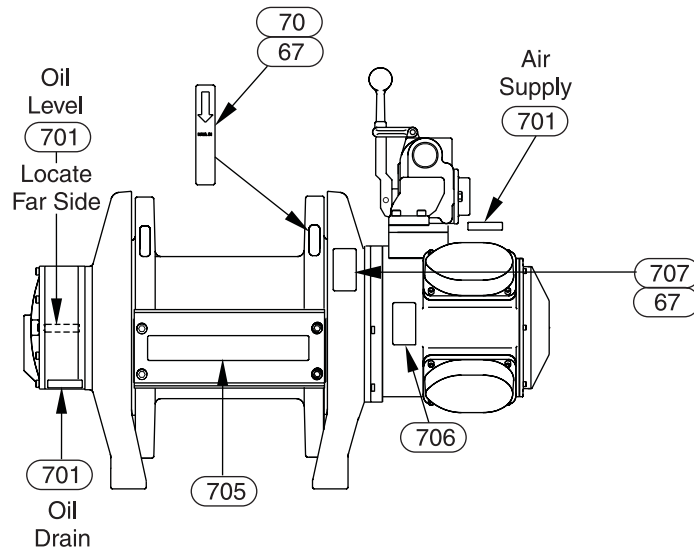

(Dwg. MHP1337)

WINCH LABEL/TAG LOCATION DRAWING PARTS LIST

ITEM NO.	DESCRIPTION OF PART	QTY. TOTAL	PART NUMBER	
			Standard	'-E' Option
67	Drive Screw	9	50915	
70	Cover, Anchor Pocket	1 *	71297824	
Label and Tag Assembly				
700	Short Drum (7 in)	1	25273-1	25973-1
	Medium Drum (13-1/2 in)		25273-2	25973-2
	Long Drum (20 in)		25273-3	25973-3
	Extra Long Drum (24 in)			
701	Label Sheet	1	71295240	
IR Logo, Rear Sideframe				
705	Short Drum (7 in)	1	71106231	
	Medium Drum (13-1/2 in)		71106256	
	Long Drum (20 in)		71106272	
	Extra Long Drum (24 in)			
706	Label, Warning: Do not handle people	1	04306445	96180100
707	Tag, Warning: General	1	71056410	---
708	Label, Throttle Direction	1	71297816	
709	IR Monogram	1	71137780	
Product Logo, Front Sideframe				
710	Short Drum (7 in)	1	71032640	
	Short Drum (7 in) (Open Frame (Face))		---	
	Medium Drum (13-1/2 in)		71111769	
	Medium Drum (13-1/2 in) (Open Frame (Face))		---	
	Long Drum (20 in)		71111777	
	Long Drum (20 in) (Open Frame (Face))		---	
	Extra Long Drum (24 in)		71111777	
	Extra Long Drum (24 in) (Open Frame (Face))		---	
711	Label, Warning: Do Not Weld	3	71270813	71271084
712	Nameplate	1	71106991	

* Not required on winches with drum band brake.

PARTS ORDERING INFORMATION

The use of other than **Ingersoll-Rand** Material Handling replacement parts may adversely affect the safe operation and performance of this product.

For your convenience and future reference it is recommended that the following information be recorded.

Model Number _____

Serial Number _____

Date Purchased _____

When ordering replacement parts, please specify the following:

1. Complete model number and serial number as it appears on the nameplate.
2. Part number(s) and part description as shown in this manual.
3. Quantity required.

The nameplate is located on the winch outboard upright.

NOTICE

- **Continuing improvement and advancement of design may cause changes to this equipment which are not included in this manual. Manuals are periodically revised to incorporate changes. Always check the manual edition number on the front cover for the latest issue.**
- **Sections of this manual may not apply to your winch.**

Refer all communications to the nearest **Ingersoll-Rand** Material Handling Office or Distributor.

Return Goods Policy

Ingersoll-Rand will not accept any returned goods for warranty or service work unless prior arrangements have been made and written authorization has been provided from the location where the goods were purchased.

Winches which have been modified without **Ingersoll-Rand** approval, mishandled or overloaded will not be repaired or replaced under warranty. A printed copy of the warranty which applies to this winch is provided inside the back cover of this manual.

Disposal

When the life of the unit has expired, it is recommended that it be disassembled, degreased and parts separated as to materials so that they may be recycled.

For additional information contact:

Ingersoll-Rand Material Handling

P.O. Box 24046
2724 Sixth Avenue South
Seattle, WA 98124-0046 USA
Phone: (206) 624-0466
Fax: (206) 624-6265

or

Ingersoll-Rand Material Handling Douai Operations

111, avenue Roger Salengro
59450 Sin Le Noble, France
Phone: (33) 3-27-93-08-08
Fax: (33) 3-27-93-08-00

HOIST AND WINCH LIMITED WARRANTY

Ingersoll-Rand Company (I-R) warrants to the original user its Hoists and Winches (Products) to be free of defects in material and workmanship for a period of one year from the date of purchase. **I-R** will repair, without cost, any Product found to be defective, including parts and labor charges, or at its option, will replace such Products or refund the purchase price less a reasonable allowance for depreciation, in exchange for the Product. Repairs or replacements are warranted for the remainder of the original warranty period.

If any Product proves defective within its original one year warranty period, it should be returned to any Authorized Hoist and Winch Service Distributor, transportation prepaid with proof of purchase or warranty card.

This warranty does not apply to Products which **I-R** has determined to have been misused or abused, improperly maintained by the user, or where the malfunction or defect can be attributed to the use of non-genuine parts.

I-R makes no other warranty, and all implied warranties including any warranty of merchantability or fitness for a particular purpose are limited to the duration of the expressed warranty period as set forth above. I-R's maximum liability is limited to the purchase price of the Product and in no event shall I-R be liable for any consequential, indirect, incidental, or special damages of any nature rising from the sale or use of the Product, whether based on contract, tort, or otherwise.

Note: Some states do not allow limitations on incidental or consequential damages or how long an implied warranty lasts so that the above limitations may not apply to you.

This warranty gives you specific legal rights and you may also have other rights which may vary from state to state.

IMPORTANT NOTICE

It is our policy to promote safe delivery of all orders.

This shipment has been thoroughly checked, packed and inspected before leaving our plant and receipt for it in good condition has been received from the carrier. Any loss or damage which occurs to this shipment while enroute is not due to any action or conduct of the manufacturer.

Visible Loss or Damage

If any of the goods called for on the bill of lading or express receipt are damaged or the quantity is short, do not accept them until the freight or express agent makes an appropriate notation on your freight bill or express receipt.

Concealed Loss or Damage

When a shipment has been delivered to you in apparent good condition, but upon opening the crate

or container, loss or damage has taken place while in transit, notify the carrier's agent immediately.

Damage Claims

You must file claims for damage with the carrier. It is the transportation company's responsibility to reimburse you for repair or replacement of goods damaged in shipment. Claims for loss or damage in shipment must not be deducted from the **Ingersoll-Rand** invoice, nor should payment of **Ingersoll-Rand** invoice be withheld awaiting adjustment of such claims as the carrier guarantees safe delivery.

You may return products damaged in shipment to us for repair, which services will be for your account and form your basis for claim against the carrier.

United States Office Locations

For Order Entry, Order Status and Technical Support

**Ingersoll-Rand
Material Handling**
P.O. Box 24046
2724 Sixth Avenue South
Seattle, WA 98124-0046
Phone: (206) 624-0466
Fax: (206) 624-6265

Ingersoll-Rand Distribution Center

P.O. Box 618
510 Hester Drive
White House, TN 37188
Phone: (615) 672-0321
Fax: (615) 672-0801

Regional Sales Offices Chicago

888 Industrial Drive
Elmhurst, IL 60126
Phone: (630) 530-3800
Fax: (630) 530-3891

Detroit, MI

23192 Commerce Drive
Farmington Hills, MI 48335
Phone: (810) 476-6677
Fax: (810) 476-6670

Houston, TX

450 Gears Road
Suite 210
Houston, TX 77067-4516
Phone: (281) 872-6800
Fax: (281) 872-6807

Los Angeles, CA

11909 E. Telegraph Road
Santa Fe Springs, CA 90670
Phone: (310) 948-4189
Fax: (310) 948-1828

Philadelphia, PA

P.O. Box 425
900 E. 8th Ave., Suite 103
King of Prussia, PA 19406
Phone: (610) 337-5930
Fax: (610) 337-5912

International Office Locations

Offices and distributors in principal cities throughout the world. Contact the nearest **Ingersoll-Rand** office for the name and address of the distributor in your country or write/fax to:

Ingersoll-Rand Material Handling

P.O. Box 24046
2724 Sixth Avenue South
Seattle, WA 98124-0046
USA
Phone: (206) 624-0466
Fax: (206) 624-6265

Canada

National Sales Office Regional Warehouse Toronto, Ontario

51 Worcester Road
Rexdale, Ontario
M9W 4K2
Phone: (416) 213-4500
Fax: (416) 213-4510
Order Desk
Fax: (416) 213-4605

Regional Sales Offices

Calgary, Alberta

44 Harley Road S.E.
Calgary, Alberta
T2V 3K3
Phone: (403) 252-4180
Fax: (403) 252-4462

Edmonton, Alberta

1430 Weber Center
5555 Calgary Trail N.W.
Edmonton, Alberta
T6H 5G8
Phone: (403) 438-5039
Fax: (403) 437-3145

Montreal, Quebec

3501 St. Charles Blvd.
Kirkland, Quebec
H9H 4S3
Phone: (514) 695-9040
Fax: (514) 695-0963

British Columbia

201-6351 Westminster Hwy
Richmond, B. C.
V7C 5C7
Phone: (604) 278-0459
Fax: (604) 278-1254

Latin America Operations

Ingersoll-Rand Production Equipment Group

730 N.W. 107 Avenue
Suite 300, Miami, FL
33172-3107
Phone: (305) 559-0500
Fax: (305) 559-7505

Europe, Middle East and Africa

Ingersoll-Rand Material Handling Douai Operations

111, avenue Roger Salengro
59450 Sin Le Noble, France
Phone: (33) 3-27-93-08-08
Fax: (33) 3-27-93-08-00

Asia Pacific Operations

Ingersoll-Rand (Japan) Ltd. Shin-Yokohama Square Bldg. (5TH Floor)

2-3-12 Shin-Yokohama,
Kouhoku-Ku, Yokohama-shi,
Kanagawa Pref. 222 Japan
Phone: 81-45-476-7800
Fax: 81-45-476-7806

Russia

Ingersoll-Rand Company

Kuznetsky Most 21/5
Moscow 103895 Russia
Phone: 7-501-921-53-21
7-501-923-91-34
Fax: 7-501-924-46-25