

# PARTS, OPERATION AND MAINTENANCE MANUAL for Ultra-Lo™ SWIVEL TROLLEY MODELS

ULM2S-003  
1/4 TON

ULM2S-005  
1/2 TON

ULM2S-010  
1 TON

ULM2S-015  
1-1/2 TON

ULM2S-020  
2 TON

ULM2S-030  
3 TON

ULM2S-040  
4 TON

ULM2S-050  
5 TON

ULM2S-060  
6 TON

Unless otherwise noted, Tons in this manual are US Tons (2,000 lbs.)

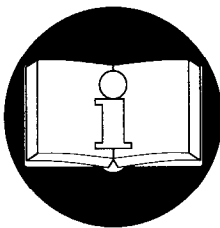
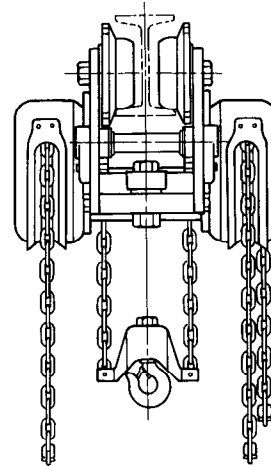
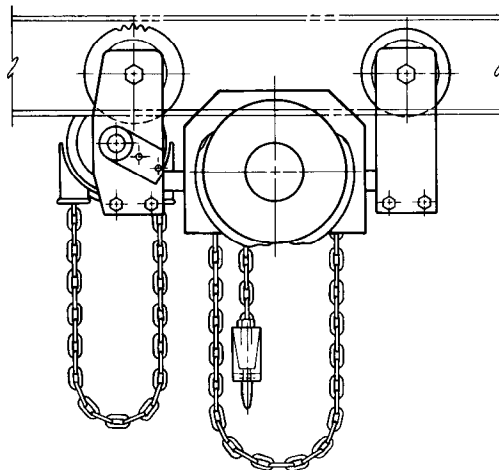

**READ THIS MANUAL BEFORE USING THESE PRODUCTS.** This manual contains important safety, installation, operation and maintenance information. Make this manual available to all persons responsible for the operation, installation and maintenance of these products.

## **⚠ WARNING**

**Do not use this hoist for lifting, supporting, or transporting people or lifting or supporting loads over people.**

**Always operate, inspect and maintain this hoist in accordance with American National Standards Institute Safety Code (B30.16) and any other applicable safety codes and regulations.**

**Refer All Communications to the Nearest Ingersoll-Rand Material Handling Office or Distributor.**

Form MHD56063  
Edition 1  
December 1992  
71115604

© 1992 Ingersoll-Rand Company

**INGERSOLL-RAND®**  
**MATERIAL HANDLING**

## SAFETY INFORMATION

This manual provides important information for all personnel involved with the safe installation, operation and proper maintenance of this product. Even if you feel you are familiar with this or similar equipment, you should read and understand this manual before operating the product.

### Danger, Warning, Caution and Notice

Throughout this manual there are steps and procedures which, if not followed, may result in a injury. The following signal words are used to identify the level of potential hazard.

#### DANGER

Danger is used to indicate the presence of a hazard which *will* cause *severe* injury, death, or substantial property damage if the warning is ignored.

#### WARNING

Warning is used to indicate the presence of a hazard which *can* cause *severe* injury, death, or substantial property damage if the warning is ignored.

#### CAUTION

Caution is used to indicate the presence of a hazard which *will* or *can* cause *minor* injury or property damage if the warning is ignored.

#### NOTICE

Notice is used to notify people of installation, operation, or maintenance information which is important but not hazard-related.

### Safety Summary

#### WARNING

- Do not use this hoist for lifting, supporting, or transporting people or lifting or supporting loads over people.
- Hoists are designed to provide a 4 to 1 safety factor and are factory tested to 125% of the rated load. The supporting structures and load-attaching devices used in conjunction with this hoist must provide adequate support to handle all hoist operations plus the weight of the hoist and attached equipment. This is the customer's responsibility. If in doubt, consult a qualified structural engineer.

The National Safety Council, Accident Prevention Manual for Industrial Operations, Eighth Edition and other recognized safety sources make a common point: Employees who work near cranes or assist in hooking on or arranging a load should be instructed to keep out from under the load. From a safety standpoint, one factor is paramount: conduct all lifting operations in such a manner that if there were an equipment failure, no personnel would be injured. This means keep out from under a raised load and keep out of the line of force of any load.

INGERSOLL-RAND Material Handling hoists are manufactured in accordance with the latest ASME B30.16 standards.

The Occupational Safety and Health Act of 1970 generally places the burden of compliance with the owner/employer, not the manufacturer. Many OSHA requirements are not concerned or connected with the manufactured product but are, rather, connected with the final installation. It is the owner's responsibility and user's responsibility to determine the suitability of a product for any particular use. It is recommended that all applicable industry, trade association, federal, state and local regulations be checked. Read all operating instructions and warnings before operation.

**Rigging:** It is the responsibility of the operator to exercise caution, use common sense and be familiar with proper rigging techniques. See ASME B30.9 for rigging information, American National Standards Institute, 1430 Broadway, New York, NY 10018.

#### NOTICE

- Using other than genuine INGENSOLL-RAND Material Handling parts will void the warranty.

## SAFE OPERATING INSTRUCTIONS

The following warnings and operating instructions have been adapted in part from American National (Safety) Standard ASME B30.16 and are intended to avoid unsafe operating practices which might lead to personal injury or property damage.

These recommendations apply to hoists used for material handling of freely suspended unguided loads.

INGERSOLL-RAND recognizes that most companies who use hoists have a safety program in force in their plants. In the event you are aware some conflict exists between a rule set forth in this publication and a similar rule already set by an individual company, the more stringent of the two should take precedence.

Safe Operating Instructions are provided to make an operator aware of dangerous practices to avoid and are not necessarily limited to the following list. Refer to specific sections in the manual for additional safety information.

1. Only allow people, (trained in safety and operation of this product) to operate the hoist.
2. Only operate a hoist if you are physically fit to do so.
3. When a "DO NOT OPERATE" sign is placed on the hoist, do not operate the hoist until the sign has been removed by designated personnel.
4. Before each shift, the operator should inspect the hoist for wear or damage.
5. Never use a hoist which inspection indicates is worn or damaged.
6. Periodically, inspect the hoist thoroughly and replace worn or damaged parts.
7. Lubricate the hoist regularly.
8. Do not use hoist if hook latch on a hook has been sprung or broken.
9. Check that the hook latches are engaged before using.
10. Never splice a hoist chain by inserting a bolt between links.
11. Only lift loads less than or equal to the rated capacity of the hoist. See warning tags attached to the hoist.
12. When using two hoists to suspend one load, select two hoists each having a rated capacity equal to or more than the load. This provides adequate safety in the event of a sudden load shift.
13. Never place your hand inside the throat area of a hook.
14. Never use the hoist chain as a sling.
15. Never operate a hoist when the load chain is not centered under the hook. Do not "side pull" or "yard."
16. Never operate a hoist with twisted, kinked, "capsized" or damaged load chain.
17. Do not force a chain or hook into place by hammering.
18. Never insert the point of the hook into a chain link.
19. Be certain the load is properly seated in the saddle of the hook.
20. Do not support the load on the tip of the hook.
21. Never run the load chain over a sharp edge. Use a sheave.
22. Pay attention to the load at all times when operating the hoist.
23. Always ensure that you, and all other people, are clear of the path of the load. Do not lift a load over people.
24. Never use the hoist for lifting or lowering people, and never allow anyone to stand on a suspended load.
25. Ease the slack out of the chain and sling when starting a lift. Do not jerk the load.
26. Do not swing a suspended load.
27. Never leave a suspended load unattended.
28. Never weld or cut a load suspended by the hoist.
29. Never use the hoist chain as a welding electrode.
30. Do not operate hoist if chain jumping, excessive noise, jamming, overloading, or binding occurs.
31. Keep the load from hitting the load chain.
32. Only operate the hoist with manual power.
33. After use, properly secure hoist and all loads.

## WARNING TAG

Each hoist is supplied from the factory with the safety tag shown. If the tag is not attached to your unit, order a new tag and install it. See the parts list for the part number. Read and obey all warnings and other safety information attached to this hoist. Tag may not be shown actual size.

### ! WARNING

Failure to follow these warnings may result in death, severe injury or property damage:

- Do not operate this hoist before reading operation and maintenance manual.
- Do not lift more than rated load.
- Do not operate hoist with twisted, kinked or damaged chain.
- Do not operate a hoist which is damaged or malfunctioning.
- Do not lift people or lift loads over people.
- Do not operate hoist with other than manual power.
- Do not remove this tag.

Read the latest edition of ASME/ANSI B30.16. Comply with other federal, state and local rules

P/N 71038863  
for manual chain hoists

**INGERSOLL-RAND**  
MATERIAL HANDLING

## SPECIFICATIONS

### Model Code Explanation

Model Code **ULM2S - GT050 - 18 - 14V**

<b>Series</b>	ULM2S (Swivel Type)	
<b>Trolley Type</b>	PT = Plain Trolley, tapered wheels PF = Plain Trolley, flat wheels PP = Plain Trolley, Patented wheels GT = Geared Trolley, tapered wheels GF = Geared Trolley, flat wheels GP = Geared Trolley, Patented wheels	
<b>Capacity</b>	003, 005, 010, 015, 020, 030, 040, <b>050</b> and 060 (See Table 1)	
<b>Lift</b>	8 = 8 ft. (2.4 m) Standard <b>18</b> = 18 ft. (5.5 m) XX = Specify Lift	
<b>Hand Chain Length</b>	6 = 6 ft. (1.8 m) Standard <b>14</b> = 14 ft. (4.3 m) XX = Specify Length	
<b>Options</b>	V = Slip Clutch* F = Corrosion resistant finish S = Spark Resistant C = Chain Container	

\* Option not covered in this manual. For additional information contact your nearest Ingersoll-Rand Material Handling Office or distributor.

**Table 1**

Model No.	Rated Capacity US tons	No. of Chain Falls on Each Side	Hand Chain Pull to Lift Rated Capacity		Hoist Weight with Standard Lift			
					Plain Trolley		Geared Trolley	
			lb	kg	lb	kg	lb	kg
ULM2S-003	1/4	1	17	7.7	110	50	127	58
ULM2S-005	1/2	1	35	15.9	110	50	127	58
ULM2S-010	1	1	70	31.8	127	58	144	66
ULM2S-015	1-1/2	2	57	25.9	245	111	267	121
ULM2S-020	2	2	76	34.5	251	114	270	123
ULM2S-030	3	2	42	19.1	345	157	375	171
ULM2S-040	4	2	58	26.4	350	159	380	173
ULM2S-050	5	2	73	33.2	466	212	496	226
ULM2S-060	6	2	90	40.9	466	212	496	226

**Table 2**

Model No.	Rated Capacity US tons	Head Room		Fits Flange Width							
				Straight track		Max. width for min. curve radius		Min. curve radius		Max. flange thickness	
		in.	mm	in.	mm	in.	mm	in.	mm	in.	mm
ULM2S-003	1/4	6	152	3.00-5.38	76.2-136.6	3.38	85.8	21	533	0.50	12.7
ULM2S-005	1/2	6	152	3.00-5.38	76.2-136.6	3.38	85.8	21	533	0.50	12.7
ULM2S-010	1	6	152	3.00-5.38	76.2-136.6	3.38	85.8	21	533	0.50	12.7
ULM2S-015	1-1/2	7	178	3.31-6.00	84.1-152.4	4.00	101.6	30	762	0.50	12.7
ULM2S-020	2	7	178	3.31-6.00	84.1-152.4	4.00	101.6	30	762	0.50	12.7
ULM2S-030	3	8	203	4.00-6.00	101.6-152.4	5.88	149.3	42	1067	0.63	16.0
ULM2S-040	4	9	229	4.00-6.00	101.6-152.4	5.88	149.3	48	1219	0.63	16.0
ULM2S-050	5	8.88	226	4.63-8.00	117.6-203.2	7.88	200.2	48	1219	0.88	22.4
ULM2S-060	6	8.88	226	4.63-8.00	117.6-203.2	7.88	200.2	48	1219	0.88	22.4

## INSTALLATION

Prior to installing the hoist, carefully inspect it for possible shipping damage.

Hoists are supplied fully lubricated from the factory.

Lubrication of the load chain is recommended before initial hoist operation.

### **⚠ CAUTION**

• Owners and users are advised to examine specific, local or other regulations, including American National Standards Institute and/or OSHA Regulations which may apply to a particular type of use of this product before installing or putting hoist to use.

### **⚠ WARNING**

• A falling load can cause injury or death. Before installing, read "SAFETY INFORMATION".

### **⚠ WARNING**

• Depending on the model selected, the hoist may weight more than 496 lbs. (226 kg). If parts of the hoist are dropped, they can cause injury or property damage. Adequately support the trolley when lifting into place on the beam.

Hoists are designed to provide a 4 to 1 safety factor and are factory tested to 125% of the rated load. The supporting structures and load-attaching devices used in conjunction with this hoist must provide adequate support to handle all hoist operations plus the weight of the hoist and attached equipment. This is the customer's responsibility. If in doubt, consult a qualified structural engineer.

The ULM2S trolleys are custom sized at the factory to fit a specific beam size. The unit is not field adjustable to suit other beams. Most units are installed by slipping the unit over the end of the monorail beam. If the monorail beam does not have an open end available, the unit can be installed by removing one trolley side plate from each trolley. After the unit is placed on the beam, reinstall these sideplates to complete the installation.

Check proper trolley wheel to beam clearance by measuring the clearance between the edge of the beam and the vertical wheel flange at the wheel tread surface. There should be 1/16 to 3/16 in. (1.6 to 4.7 mm) total clearance at this point. This clearance should be checked before operating the hoist under load.

### **Initial Operating Checks**

1. The hoist should be traversed the entire length of the runway beam to check for interference points, proper clearances and effectiveness of beam stops before loading the hoist.
2. Run in the hoist with a light load by raising and lowering this load several times. Verify the load brake operation with this light load prior to applying heavier loads.

### **NOTICE**

• Each time a load is lifted, the operation of the load brake should be checked by raising the load slightly and stopping to ensure the brake will hold the load before proceeding to lift the load.

Familiarize operator and people responsible for hoist installation and service with the ASME B30.16 specifications prior to placing the unit into service. All the requirements of this specification, including testing should be met before approving the hoist for operation.

## OPERATION

The four most important aspects of hoist operation are:

1. Follow all safety instructions when operating the hoist.
2. Allow only people trained in the operation of this hoist to operate the hoist.
3. Subject each hoist to a regular inspection and maintenance procedure.
4. Be aware of the hoist capacity and weight of load at all times.

### WARNING

- Only allow personnel trained in safety and operation on this hoist to operate the hoist.
- The hoist is not designed or suitable for lifting, lowering or moving persons. Never lift loads over people.

### Hook Movement

When facing the hand chain side of the hoist:

1. Rotate hand chain clockwise to raise load.
2. Rotate hand chain counterclockwise to lower load.

### NOTICE

- The clicking sound of the pawl on the ratchet gear is normal when a load is being raised.

Raising or lowering a load is accomplished by gear reduction. To raise, the operator pulls on the right hand chain to rotate the handwheel. The handwheel then transmits the pull through the spindle, which is actually a driving pinion, to the two cluster gears (gear and pinion).

The gears with their integral pinions are mounted and revolve on fixed axles carried by the pinion cage. This pinion cage receives rotary motion from the meshing of the two cluster gears (gear and pinion) with the internal gear which is part of the internal gear frame. The hollow load shaft is attached to the pinion cage through splines cut on the load shaft and is anchored with a set screw and lock nut.

This load shaft then transmits rotary motion directly to the load sheaves mounted directly on the load shaft. The load sheaves pick up and carry the load chain, thereby completing the transmission of hand chain pull to the load chain.

Substantial hand chain pull is required to lift loads at or near rated capacity. If a hand chain pull is considered excessive, measure the pull with a capacity load and compare with the data in the "SPECIFICATION" section. If hand chain pull is more than 10% above the data provided, proceed with the steps provided in the "TROUBLESHOOTING" section.

### Load Locking Action

There is an intermediate action in the hoist before the load lifts. When the handwheel advances on the screw thread on the spindle, it clamps the brake discs and the ratchet tightly between the handwheel and the spindle flange, which causes all four parts to operate as a single unit when lifting. The spindle by means of its driving pinion, transmits the pull on the hand chain into the gear reduction.

When the operator stops pulling on the hand chain, the load, in attempting to run down, causes the ratchet disc to engage a pawl, and the handwheel and disc hub advancing on the screw threads tightens on the brake disc to prevent the load from descending. A slight pull by the operator on the lift hand chain releases the pressure on the brake discs, permitting the brake to become a friction clutch enabling the load to descend slowly.

### Traversing the Hoist

Motion along the beam on hand geared units is accomplished by imparting movement to the geared trolley wheels through the trolley hand chain and handwheel. A trolley drive shaft connects the trolley drive pinions and the trolley hand chain wheel; then a pull on the trolley hand chain gives motion to the trolley hoist.

### Trolley Brakes

ULM2S hoists can be equipped with track clamps and chain actuated handwheel. This assembly consists of steel shoes with a serrated face to grip the toe of the runway beam. These shoes are actuated through a track clamp screw that has a left and right hand thread on the same shaft. The shaft is caused to rotate by a track clamp handwheel that carries a special hand chain. A pull on the hand chain thus causes the shoes to engage or back away from the toe of the monorail.

There are two types of inspection, the frequent inspection performed by the operator while using the hoist and periodic inspections performed by personnel trained in the operation and maintenance of this hoist. Careful inspection on a regular basis will reveal potentially dangerous conditions while still in the early stages, allowing corrective action to be taken before the condition becomes dangerous.

Any deficiency revealed through inspection must be reported to an appointed person. A determination must be made as to whether a deficiency constitutes a safety hazard before resuming operation of the hoist.

### Records and Reports

Some form of inspection record should be maintained for each hoist, listing all points requiring periodic inspection. A written report should be made monthly on the condition of the critical parts of each hoist. These reports should be dated, signed by the person who performed the inspection, and kept on file where they are readily available to authorized personnel.

### Frequent Inspection

On a hoist in continuous service, frequent inspection should be made at the beginning of each shift. In addition, visual inspections should be conducted during regular service for any damage or evidence of malfunction.

1. **OPERATION.** Check for visual or abnormal noises which could indicate a defect. Do not operate a hoist unless the chain feeds through the hoist and hook block smoothly. Listen for "clicking", binding or malfunctioning. The clicking sound of the pawl on the ratchet gear is normal when a load is being raised. If chain binds, jumps, or is excessively noisy, clean and lubricate the chain. If problem persists, replace the chain. Do not operate the hoist until all defects have been corrected. Check that hand chain moves freely and without binding or excessive drag. Hook should stop moving when hand chain stops moving.
2. **HOOKS.** Check for wear or damage, increased throat width, bent shank or twisting of hook. Replace hooks which exceed the throat opening discard width specified in table 3 (ref. Dwg. MHTPA0040) or exceed a 10° twist (ref. Dwg. MHTPA0111). If the hook latch snaps past the tip of the hook, the hook is sprung and must be replaced. Check hook support bearings for lubrication and damage. Make sure that they swivel easily and smoothly. Repair or lubricate as necessary.

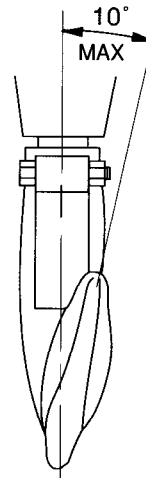

**TWISTED  
DO NOT USE**

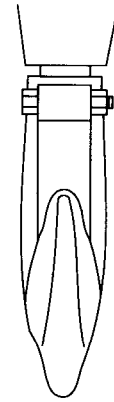

**NORMAL  
CAN BE USED**

(Dwg. MHTPA0111)

**Table 3**

Model No.	Throat Width		Discard Width	
	in.	(mm)	in.	(mm)
ULM2S-003	1.03	26.2	1.18	30.1
ULM2S-005	1.03	26.2	1.18	30.1
ULM2S-010	1.03	26.2	1.18	30.1
ULM2S-015	1.22	31.0	1.40	35.6
ULM2S-020	1.22	31.0	1.40	35.6
ULM2S-030	1.50	38.1	1.72	43.8
ULM2S-040	1.87	47.5	2.15	54.6
ULM2S-050	1.87	47.5	2.15	54.6
ULM2S-060	1.87	47.5	2.15	54.6

Throat width dimensions given are manufacturer's nominal and may vary due to forging tolerances. The dimensions given are for reference. Measure and record the throat opening of the load hook before placing the unit into service.

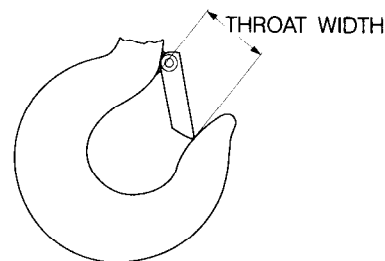

(Dwg. MHTPA0040)

3. **HOOK LATCH.** Check operation of the hook latch. Replace if broken or missing. If the hook latch passes through the throat of the hook, the hook has been severely overloaded and must be replaced.



4. **CHAIN.** Examine each of the links for bending, cracks in weld areas or shoulders, transverse nicks and gouges, weld splatter, corrosion pits, striation (minute parallel lines) and chain wear, including bearing surfaces between chain links. Replace a chain that fails any of the inspections. Check lubrication and lubricate if necessary. See "Load Chain" under "LUBRICATION."

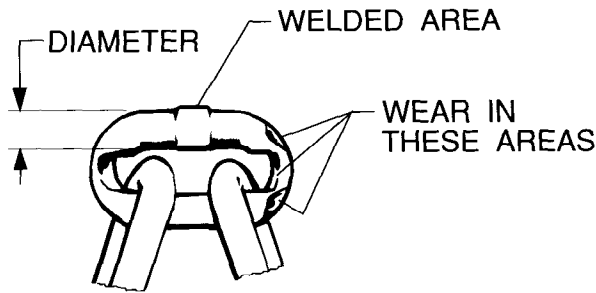

(Dwg. MHTPA0102)

### NOTICE

- Excessive wear or stretching may not be apparent from visual observation. Also inspect chain by measuring five links in accordance with instructions in "Periodic Inspection."
- A worn load chain may cause damage to the load sheave. Inspect the load sheave and replace if damaged or worn.

5. **LOAD CHAIN REEVING.** Make sure welds on standing links are away from load sheave. Re-install chain if necessary. Make sure chain is not capsized, twisted or kinked. Adjust as required.

### Periodic Inspection

According to ASME B30.16, frequency of periodic inspection depends on the severity of usage:

NORMAL	HEAVY	SEVERE
yearly	semi-annually	quarterly.

Disassembly may be required for HEAVY or SEVERE usage. Keep accumulative written records of periodic inspections to provide a basis for continuing evaluation.

Inspect all items in "Frequent Inspection." Also inspect the following:

1. **FASTENERS.** Check rivets, capscrews, nuts, cotter pins and other fasteners on hooks, hoist body and chain bucket, if used. Replace if missing and tighten or secure if loose.

2. **ALL COMPONENTS.** Inspect for wear, damage, distortion, deformation and cleanliness. If external evidence indicates the need, disassemble. Check gears, shafts, bearings, sheaves, chain guides, springs and covers. Replace worn or damaged parts. Clean, lubricate and reassemble. Remove gear cover to inspect gear train.
3. **HOOK.** Inspect hooks for cracks. Use magnetic particle or dye penetrant to check for cracks. Inspect hook retaining parts. Tighten or repair, if necessary. Refer to ANSI B30.6 for additional hook inspection information.
4. **CHAIN SHEAVES.** Check for damage or excessive wear. Replace damaged parts.
5. **BRAKES.** Ensure proper operation. Brake should not slip with test load (10% of capacity). If external inspection indicates the need, disassemble. Brake discs should be free of excess oil, any grease, unglazed, uniform in thickness and at least 5/64 in. (2 mm) thick. Check all other brake surfaces for wear, deformation or foreign deposits. Check pawl brake. Teeth of ratchet gear should be undamaged, and should stop gear rotation in the counterclockwise direction. Check pawl spring for damage. Replace brake ratchet, pawl or pawl spring if badly worn or damaged.
6. **SUPPORTING STRUCTURE.** If a permanent structure is used inspect for continued ability to support load.
7. **LABELS AND TAGS.** Check for presence and legibility. Replace if necessary.
8. **END ANCHOR.** Ensure end anchor of chain hoist is engaged and undamaged. Repair damage or replace end anchor fasteners as needed. See "Attaching End of Load Chain" under "MAINTENANCE."
9. **LOAD CHAIN.** Measure the chain for stretching or excessive wear by measuring across five link sections all along the chain (ref. Dwg. MHTPA0041). When any five links in the working length reaches or exceeds the discard length, replace the entire chain. See Table 4. Always use a genuine INGERSOLL-RAND Material Handling replacement chain.

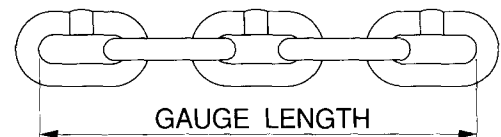

(Dwg. MHTPA0041)

**Table 4**

Load Chain size for all models is 9/32 in.

Model No.	Part No.	Normal Length		Discard Length	
		in.	(mm)	in.	(mm)
ULM2S-003	LC3805	3.98	101.2	4.08	103.6
ULM2S-005	LC3805	3.98	101.2	4.08	103.6
ULM2S-010	LC3805	3.98	101.2	4.08	103.6
ULM2S-015	LC3805	3.98	101.2	4.08	103.6
ULM2S-020	LC3805	3.98	101.2	4.08	103.6
ULM2S-030	LC3805A	3.98	101.2	4.08	103.6
ULM2S-040	LC3805A	3.98	101.2	4.08	103.6
ULM2S-050	LC3805A	3.98	101.2	4.08	103.6
ULM2S-060	LC3805A	3.98	101.2	4.08	103.6

**Note:** Zinc plated chain for the ULM2S hoist is designated by the letters "ZP" at the end of the part number

### Hoists not in Regular Service

A hoist that has been idle for a period of one month or more, but less than one year shall be given an inspection conforming with the requirements of "Frequent Inspection."

A hoist that has been idle for a period of one year or more shall be given an inspection conforming with the requirements of "Periodic Inspection."

## LUBRICATION

### Brake

The brake requires no lubrication. However, while it is preferable not to lubricate it, the brake will operate efficiently regardless of lubrication on its surfaces.

### Bearings

Lubricate with a good grade of lithium base grease recommended for anti-friction bearings, approximately A.S.T.M. working penetration 265-295, (\*) NLGI No. 2.

(\*) NLGI - National Lubricating Grease Institute.

### Trolley Wheels

Life time lubricated and sealed bearings are provided on all 1/4 through 2 ton capacity units. Ball check hydraulic grease fittings are supplied in the wheels of all 3 through 6 ton capacity units. Lubricate with a good grade of lithium based grease, NLGI No. 2.

### Gears

Remove old grease and replace with new. Use a grease appropriate to the temperature range:

Use a high grade non-corrosive extreme pressure lithium based grease, NLGI No. 2.

-20° to 50° F (-29° to 10° C) EP 1 grease or equivalent.

30° to 120° F (-1° to 49° C) EP 2 grease or equivalent.

### Load Chain

The usable life of a load chain can be appreciably increased by lubricating the chain at frequent intervals. Unlubricated chain wears rapidly from friction with the pocket wheel as well as with its own inter-links. (see Dwg. MHTPA0102)

### WARNING

• **Failure to maintain clean and well lubricated load chain will cause premature failure of the chain and void the manufacturer's warranty.**

1. Lubricate load chain weekly, or more frequently, depending on severity of service.
2. In a corrosive environment, lubricate more frequently than normal.
3. Lubricate each link of the chain and apply new lubricant over existing layer.
4. Lubricate hook and hook latch pivot points.
5. Clean chain with acid free oil solvent to remove rust or abrasive dust build-up.
6. Lubricate load chain with Lubri-Link® or a SAE 10 to 20W oil.

## TROUBLE SHOOTING

This section provides the information necessary for troubleshooting this hoist. The troubleshooting guide provides a general outline of problems which could be experienced with normal use of this hoist. It lists the symptom, the possible cause, and the possible remedy for the trouble being experienced.

SYMPTOM	CAUSE	REMEDY
Brake fails to hold load.	<p>Worn brake components.</p> <p>Brake discs glazed or worn unevenly.</p> <p>Pawl seized up and not engaging ratchet.</p> <p>Threaded disc hub tight on spindle.</p>	<p>Inspect entire brake mechanism, replace parts as needed.</p> <p>Clean or replace brake discs.*</p> <p>Remove, clean and relubricate pawl and pawl spring assembly.</p> <p>Remove, clean and relubricate square thread.</p>
Load chain operation is noisy and/or jerky.	<p>Chain lacks proper lubrication.</p> <p>Load chain and/or load sheave excessively worn.</p> <p>Load chain and/or load sheave dirty and fouled with foreign material.</p>	<p>Clean and lubricate load chain as described in "LUBRICATION" section.</p> <p>Inspect and replace load chain and/or load sheave as described in "INSPECTION" section.</p> <p>Clean load chain and load sheave. Lubricate load chain.</p>
Hand chain pull is excessive to raise load.	<p>Load is in excess of rated capacity.</p> <p>Gear train lacks proper lubrication.</p> <p>Bearing failure.</p>	<p>Reduce load to within rated capacity. Never attempt to lift a load in excess of rated capacity.</p> <p>Clean and lubricate gear train as described in "LUBRICATION" section.</p> <p>Inspect pinion and load shaft bearings. Replace or lubricate as required.</p>
Hand chain pull is excessive to lower load.**	<p>Brake mechanism is overtightened due to impact loading.</p> <p>Brake mechanism is dirty or fouled with foreign matter.</p> <p>Brake mechanism is incorrectly adjusted.</p>	<p>Free up brake by jerking down on hand chain. Hand chain pull should return to normal.</p> <p>Clean, inspect and reassemble brake mechanism.</p> <p>Readjust brake to proper setting.</p>

\* After servicing brake, always check brake operation under load prior to placing the unit back into service.

\*\* Hand pull required to lower a load can vary substantially, depending on the weight of the load and condition of the brake.

**⚠ WARNING**

- Before performing maintenance, disconnect all loads from the hoist. A falling load could cause injury or death and damage to property.
- Before starting maintenance, tag hoist:  
**DANGER - DO NOT OPERATE - EQUIPMENT BEING REPAIRED.**
- Only allow personnel trained in service and repair on this hoist to perform maintenance.
- After performing maintenance on load bearing parts, test unit to 100% of its rated capacity before returning to service.
- Provide adequate support for the trolley if hoist must be removed for repair. The hoist may weight more than 496 lbs. (226 kg). If parts of the hoist are dropped, they can cause injury or property damage.

**Installing New Load Chain**

1. When replacing load chain, two strands are required and each must be exactly the same length.
2. The starting chain link on each chain must be simultaneously fed into the two lifting load sheaves while operating the hoist in the upward direction.
3. The starting links must pass over the top of the load sheave in a horizontal position to permit end attachment of the dead end without twisting the chain.
4. The second link of chain will be a standing link of chain; this link should have the weld furthest away from the center of the load sheave. See Dwg. MHTPA0042.

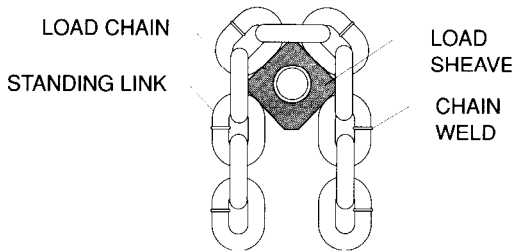

(Dwg. MHTPA0042)

5. Dead end the unloaded loop of chain on the hoist frame using the bolts supplied making sure the chain is not twisted.
6. Dead end the loaded pair of chains as follows (see Dwg. MHTPA0378):

On 1/4 through 1 ton units, dead end the load chain on the bottom block, using the dead end studs provided and making sure the chain is not twisted.

On 1-1/2 through 6 ton units, reeve the chains around the bottom block idler sheaves (66) and dead end the chain using the bolts provided on the dead end bales (45) making sure the chain is not twisted.

**NOTICE**

- The dead end bolts provided are special high strength bolts. Use only Ingersoll-Rand replacement dead end bolts.

**Chain Reeving  
Viewed from handwheel side**

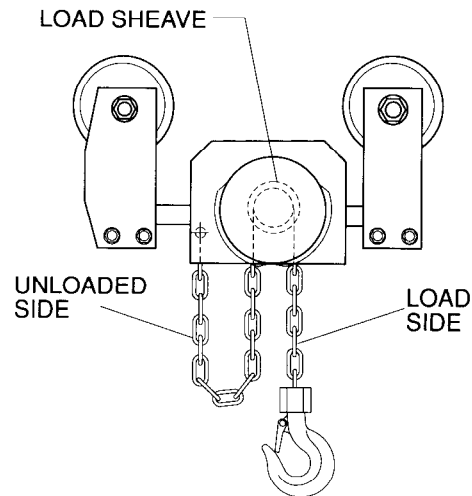

1/4, 1/2 AND 1 TON HOISTS

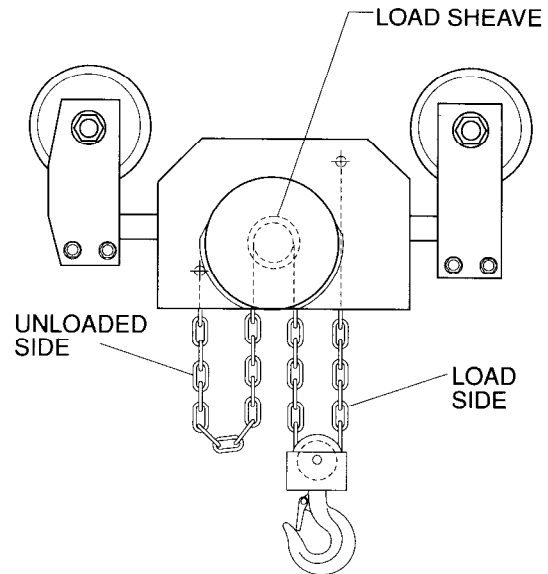

1-1/2, 2, 3, 4, 5 AND 6 TON HOISTS

(Dwg. MHTPA0378)

## General Disassembly

The following instructions provide the necessary information to disassemble, inspect, repair, and assemble the hoist. Parts drawings of the hoist assembly are provided in the Parts Section.

If a hoist is being completely disassembled for any reason, follow the order of the topics as they are presented.

It is recommended that all maintenance work on the hoist be performed on a bench in a clean, dust free work area. In the process of disassembling the hoist, observe the following:

1. Never disassemble the hoist any further than is necessary to accomplish the needed repair. A good part can be damaged during the course of disassembly.
2. Never use excessive force when removing parts. Tapping gently around the perimeter of a cover or housing with a soft hammer, for example, is sufficient to break the seal.
3. Do not heat a part with a torch to free it for removal, unless the part being heated is already worn or damaged beyond repair and no additional damage will occur to other parts.

In general, the hoist is designed to permit easy disassembly and assembly. The use of heat or excessive force should not be required.

4. Keep the work area as clean as practical, to prevent dirt and other foreign matter from getting into bearings or other moving parts.
5. All seals and 'O' rings should be discarded once they have been removed. New seals and 'O' rings should be used when assembling the hoist.
6. When grasping a part in a vise, always use leather-covered or copper-covered vise jaws to protect the surface of the part and help prevent distortion. This is particularly true of threaded members and housings.
7. Do not remove any part which is press fit in or on a subassembly unless the removal of that part is necessary for repairs or replacement.

### Disassembly to Replace Brake Discs

To remove brake discs (14), disassemble the hoist with the following procedure:

1. Lower the hoist bottom block to the floor and wire the load chains together below the load sheaves to prevent free running of the load chain when the brake mechanism is disengaged.
2. Remove the handwheel cover screws (69) and remove the handwheel cover (21) with the loop of hand chain (40).
3. Inspect the brake mechanism and check the pawl (24) and ratchet (22) engagement prior to disassembling the brake mechanism.

4. Remove the cotter pin (19) from the end of the driving spindle (7). Remove the adjustable check ring (17). Unscrew and remove the handwheel (16) and handwheel threaded insert (15).
5. Holding back on the pawl (24), remove the ratchet (22) and the brake discs (14).

### Cleaning, Inspection and Repair

Use the following procedures to clean, inspect, and repair the components of the hoist.

#### Cleaning



- Bearings that are loose, worn or rotate in the frame must be replaced. Failure to observe this precaution will result in additional component damage.
- Do not use trichloroethylene to clean parts.

Clean all hoist component parts in solvent (except for the brake discs). The use of a stiff bristle brush will facilitate the removal of accumulated dirt and sediments on the gears and frames. If bushings have been removed it may be necessary to carefully scrape old Loctite® from the housing bores. Dry each part using low pressure, filtered compressed air.

#### Inspection

All disassembled parts should be inspected to determine their fitness for continued use. Pay particular attention to the following:

1. Inspect all gears for worn, cracked, or broken teeth.
2. Inspect all bushings for wear, scoring, or galling.
3. Inspect shafts for ridges caused by wear. If ridges caused by wear are apparent on shafts, replace the shaft.
4. Inspect all threaded items and replace those having damaged threads.
5. Measure the thickness of the brake discs. If the brake discs are less than 5/64 in. (2 mm) or are worn unevenly replace the brake discs.
6. Inspect bushings for wear, scoring, or galling. If bore size exceeds discard dimension replace bushings. See Table 5.

**Table 5**

Bushing Location	Bushing Item No.	Original Bore Size		Discard Bore Size	
		in.	mm	in.	mm
Bearing Cap	6	0.625	15.9	0.6875	17.5
Handwheel Cover	18	0.625	15.9	0.6875	17.5
Idler Sheave	67	1.253	31.8	1.312	33.3

7. Inspect bottom hook for excessive wear or opening. Examine the bolt attaching the load chain to the bottom block or top dead end shackle for damage or loosened locking nut.
8. Test the brake mechanism, by operating the hoist under load, to determine if the brake is holding the load at all positions. If the brake fails to hold properly, brake parts should be disassembled and thoroughly cleaned. Check for excess wear or other damage, then reassemble and again test under load.
9. Remove the gear cover and inspect all gearing. Check all gear teeth for excess wear or other damage.
10. Inspect trolley wheels, visually, for damage or wear. Push-pull and hand-gearred trolleys should also be checked for proper ease of traverse along the supporting track.
11. Replace the load sheave when its pockets become excessively worn. If the sheave is replaced, do not use stretched or badly worn chain and risk damaging the new sheave pockets.
12. Replace brake assembly washers, pawl or pawl spring if badly worn or damaged

### Repair

Actual repairs are limited to the removal of small burrs and other minor surface imperfections from gears and shafts. Use a fine stone or emery cloth for this work.

1. Worn or damaged parts must be replaced. Refer to the applicable parts listing for specific replacement parts information.
2. Inspect all remaining parts for evidence of damage. Replace or repair any part which is in questionable condition. The cost of the part is often minor in comparison with the cost of redoing the job.
3. Smooth out all nicks, burrs, or galled spots on shafts, bores, pins, or bushings.
4. Examine all gear teeth carefully, and remove nicks or burrs.
5. Polish the edges of all shaft shoulders to remove small nicks which may have been caused during handling.
6. Remove all nicks and burrs caused by lockwashers.

### Assembly After Replacing Brake Discs

1. Place one brake disc (14) on the driving spindle (7). If the pair of brake discs supplied are different sizes, the large disc goes on first.
2. Holding back on the pawl (24), install the brake ratchet (22) and the second brake disc (14).
3. Screw the handwheel (16) and the threaded insert (15) on to the driving spindle (7) until it stops against the brake mechanism.
4. Without moving the handwheel, install the adjustable check ring (17) as shown in Dwg. MHTPA0375, so when the cotter pin (19) is installed, there is 1/4 in. (6.4 mm) clearance as shown. This is the only adjustment required to insure proper brake operation.

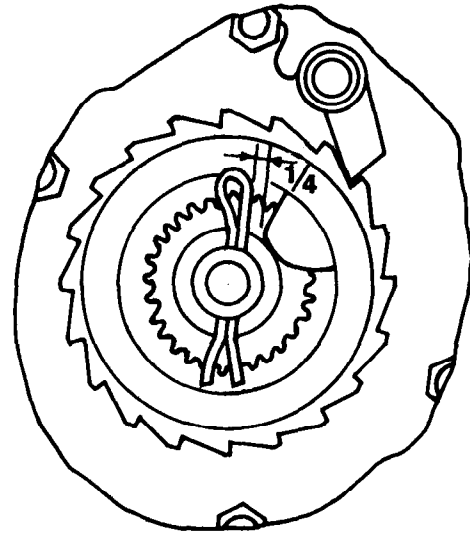

(Dwg. MHTPA0375)

5. Reinstall the loop of hand chain (40) over the hand-wheel (16) and then install handwheel cover (21). Secure the cover with the handwheel cover screws (69).
6. Remove the wire securing the load chain and test the operation of the brake prior to placing the hoist back in service. Refer to "OPERATION" section.

### Timing the Hoist Gear Train During Reassembly

Should it ever become necessary to dismantle the hoist, extreme care must be exercised in reassembling the cluster gears in the internal gear frame. Punch marks on the pinion gears must be in direct line with each other as shown in Dwg. MHTPA0374 to mesh properly in this planetary gear system. After assembly, operate the hoist to verify the gear train is properly timed and runs smoothly. If the gear train binds up after making a partial revolution, it is not properly timed and must be disassembled and timed to prevent severe damage to the gear train.

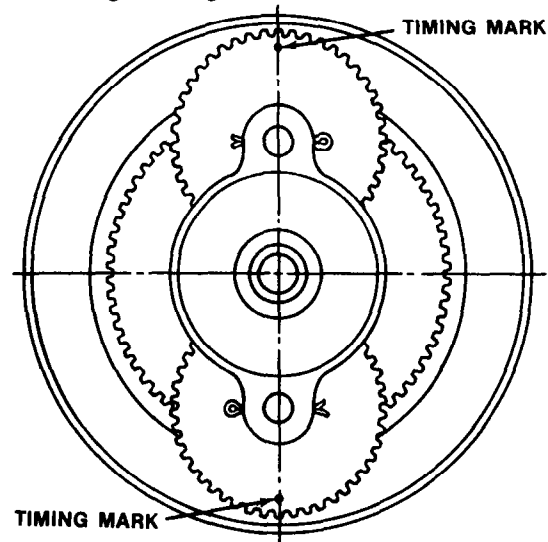

(Dwg. MHTPA0374)

## **Hoist Options**

### **Chain Bucket**

Chain buckets can be supplied with these hoists or added to contain the idle loop of load chain. The chain buckets are connected to the hoist frame with a chain container bracket.

This bracket is bolted to holes in the hoist frame. Each chain bucket is sized specifically for the amount of chain supplied with the hoist, therefore, when ordering a chain bucket for a hoist in the field, specify the hoist serial number so the bucket can be sized properly.

### **Slip Clutch (Load Limiter)**

Slip clutches can be supplied in these hoists to prevent an overload from damaging the hoist mechanism. The slip clutch is preset at the factory and has no user serviceable parts or adjustments.

### **Load Test**

Prior to initial use, all new, extensively repaired, or altered hoists shall be load tested by or under the direction of a qualified person, and a written report furnished confirming the rating of the hoist. Test hoist to 100% of its rated capacity. Testing to more than 100% may be necessary to comply with standards and regulations set forth in areas outside of the USA.

ULM2S HOIST PARTS DRAWING

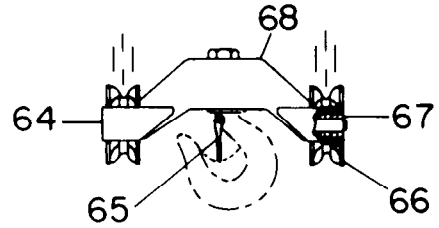
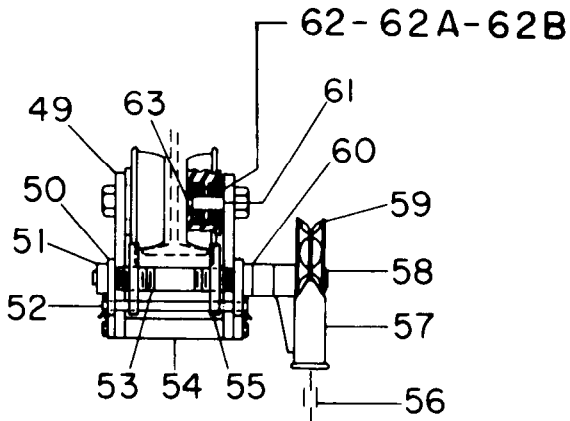
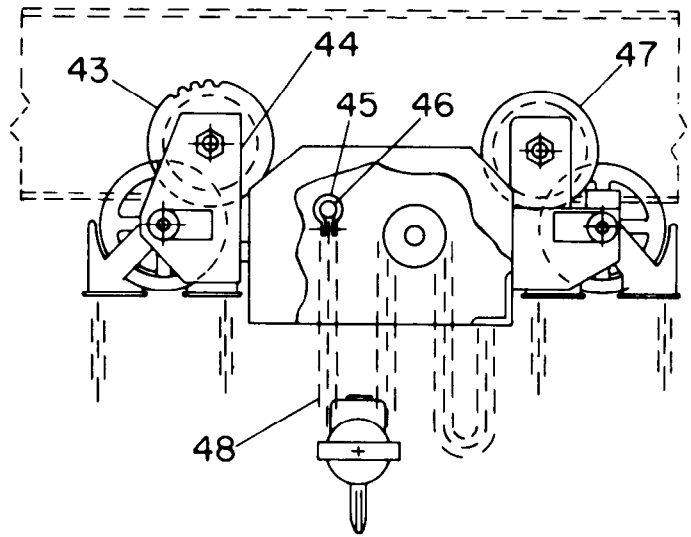
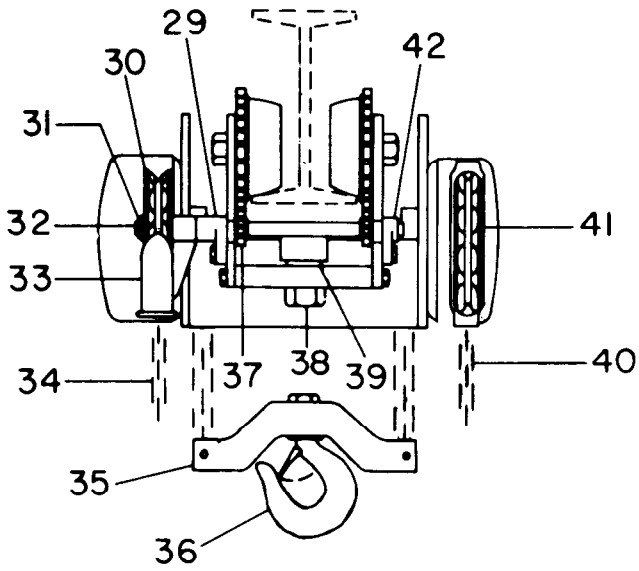

REEVED BOTTOM BLOCK  
1½-2-3-4 TON ONLY

CHAIN OPERATED TRACK CLAMP

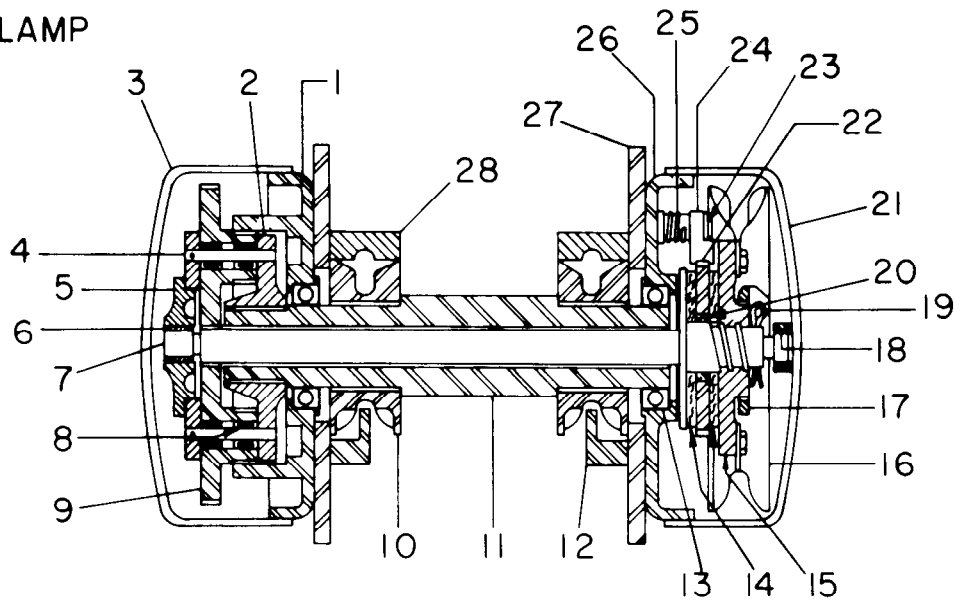

ON SOME HOISTS PARTS  
10 AND 11 ARE COMBINED  
OR IS A ONE PIECE CASTING.

(Dwg. MHTPA0371)



## ULM2S 1/4 to 2 ton HOIST PARTS LIST

Item No.	Description of Part	Qty Total	Part Number			
			1/4 & 1/2	1	1-1/2	2
1	Internal Gear Frame	1	RC-9620-G-010			
2	Pinion Cage	1	RC-921-010			
3	Gear Cover	1	RC-930-005			
4	Gear and Pinion Shaft	2	RC-919-005			
5	Pinion Cage Bearing Block with Bushing	1	RC-959-005			
6	Bushing (Part of item 5)	1	RC-906-005			
7	Spindle	1	RC-9618-005		RC-9618-015	
8	Bearing for Gear and Pinion	4	RC-922-005			
9	Gear and Pinion	2	RC-927-010			
10	Load Sheave	2	RC-929-005			
11	Splined Load Shaft	1	RC-9674-005		RC-9674-015	
12	Stripper	2	RC-9624-0025		RC-9624-015	
13	Load Shaft Bearing	2	RC-960-005			
14	Brake Disc (Pair)	1	RC-934-005			
15	Handwheel Threaded Insert	1	RC-916-005			
16	Handwheel	1	RC-928-005			
17	Adjustable Check Ring	1	RC-925-005			
18	Bushing in Handwheel Cover	1	RC-903-005			
19	Cotter Pin	1	RC-909-005			
20	Ratchet Bushing (For item 22)	1	RC-907-005			
21	Handwheel Cover (Incl's item 18)	1	RC-968-005			
22	Ratchet (Incl's item 20)	1	RC-935-005			
23	Pawl Retainer Ring	1	RC-908-005			
24	Pawl	1	RC-923-005			
25	Pawl Spring	1	RC-910-005			
26	Handwheel Side Frame	1	RC-9620-H-010			
27	Hoist Frame	1	RC-9685-0025		RC-9685-015	
28	Chain Guide	4	RC-9605-0025		RC-9605-015	
29	Handwheel Shaft Support (Long)	1	RC-906-A			
30	Trolley Handwheel	1	RC-9120-005		RC-9120-0075	
31	Trolley Drive Shaft Retainer Ring	1	R-5100-87			
32	Trolley Drive Shaft	1	RC-9611-0025		RC-9611-015	
33	Trolley Handwheel Swinging Guard	1	RC-9121-005		RC-9121-0075	
34	Trolley Drive Hand Chain	1	LC-937			
35	Bottom Cross Head	1	RC-9652-0025		---	
36	Bottom Load Hook and Nut	1	RC-9640-0025		RC-9640-015	
37	Pinion Gear	2	RC-14-T		RC-16-T	
38	Swivel Bolt and Nut	2	R-14-.87-3.00		R-14-.87-3.75	
39	Cross Piece Bushing(s)	2	RC-981-015			
	Bearing		---			
40	Hoist Hand Chain	1	RC-937			
41	Hand Chain Guide	2	RC-914-005			
42	Trolley Handwheel Shaft Support (Short)	1	RC-906-B			

**ULM2S 3 to 6 ton HOIST PARTS LIST (cont'd)**

Item No.	Description of Part	Qty Total	Part Number		
			3	4	5 & 6
1	Internal Gear Frame	1	RC-9620-G-015		RC-9620-G-050
2	Pinion Cage	1	RC-921-015		
3	Gear Cover	1	RC-930-015		
4	Gear and Pinion Shaft	2	RC-919-015		
5	Pinion Cage Bearing Block with Bushing	1	RC-959-015		
6	Bushing (Part of item 5)	1	RC-906-015		
7	Spindle	1	RC-9618-030	RC-9618-050	
8	Bearing for Gear and Pinion	4	RC-922-015		
9	Gear and Pinion	2	RC-927-020		
10	Load Sheave	2	RC-929-010		
11	Splined Load Shaft	1	RC-9674-030	RC-9674-050	
12	Stripper	2	RC-9624-030		
13	Load Shaft Bearing	2	RC-960-015	RC-960-050	
14	Brake Disc (Pair)	1	RC-934-015		
15	Handwheel Threaded Insert	1	RC-916-015		
16	Handwheel	1	RC-928-015		
17	Adjustable Check Ring	1	RC-925-005		
18	Bushing in Handwheel Cover	1	RC-903-015		
19	Cotter Pin	1	RC-909-015		
20	Ratchet Bushing (For item 22)	1	RC-907-005		
21	Handwheel Cover (Incl's item 18)	1	RC-968-015		
22	Ratchet (Incl's Bushing item 20)	1	RC-935-015		
23	Pawl Retainer Ring	1	RC-908-005		
24	Pawl	1	RC-923-005		
25	Pawl Spring	1	RC-910-015		
26	Handwheel Side Frame	1	RC-9620-H-015	RC-9620-H-050	
27	Hoist Frame	1	RC-9685-030	RC-9685-050	
28	Chain Guide	4	RC-9605-030	RC-22646	
29	Handwheel Shaft Support (Long)	1	RC-906-A	RC-32385	
30	Trolley Handwheel	1	RC-9120-0075	RC-9120-010	
31	Trolley Drive Shaft Retainer Ring	1	R-5100-87		
32	Trolley Drive Shaft	1	RC-9611-030	RC-9611-050	
33	Trolley Handwheel Swinging Guard	1	RC-9121-0075	RC-9121-010	
34	Trolley Drive Hand Chain	1	LC937		
35	Bottom Cross Head	1	---		
36	Bottom Load Hook and Nut	1	RC-9640-030	RC-9640-040	RC-9640-050
37	Pinion Gear	2	RC-16-T		RC-911A-6
38	Swivel Bolt and Nut	2	RC-9658-R1-030		RC-9658-R1-050
39	Cross Piece Bushing(s)	2	RC-9681-030		RC-9681-050
	Bearing		RC-9639-030		RC-9639-050
40	Hoist Hand Chain	1	RC-937		
41	Hand Chain Guide	2	RC-914-015		
42	Trolley Handwheel Shaft Support (Short)	1	RC-906-B	RC-32384	

**ULM2S 1/4 to 2 ton HOIST PARTS LIST (cont'd)**

Item No.	Description of Part	Qty Total	Part Number			
			1/4 & 1/2	1	1-1/2	2
43	Geared Trolley Wheel	2	RC-9108-010		RC-9108-015	
44	Geared Trolley Side Plate	2	RC-9683-G-0025		RC-9683-G-015	
45	Dead End Bale	-	---		RC-9293-015	
46	Dead End Stud	-	---		RC-689-015	
47	Plain Trolley Wheel, Geared Unit Qty. - ( )	4(2)	RC-9109-010		RC-9109-015	
48	Load Chain	2	LC3805			
	Load Chain (Zinc Plated)		LC3805ZP			
49	Plain Trolley Side Plate, Geared Unit Qty. - ( )	4 (2)	RC-9683-0025		RC-9683-015	
50	Track Clamp Side Plate	2	RSTTC-153-B-005		RSTTC-153-B-015	
51	Track Clamp Screw Support (Short)	1	RC-906B			
52	Track Clamp Guide Pin	1	RSTTC-152-005		RSTTC-152-015	
53	Track Clamp Screw	1	RSTTC-151-005		RSTTC-151-015	
54	Cross Piece	2	RC-9684-0025		RC-9684-015	
55	Track Clamp Jaw (Pair)	1	RSTTC-150-005		RSTTC-150-015	
56	Track Clamp Hand Chain	1	RC-417		RC-937	
57	Track Clamp Handwheel Swinging Guard	1	RC-9121-005		RC-9121-0075	
58	Track Clamp Screw Snap Ring	1	R5100-87			
59	Track Clamp Handwheel	1	RC-9120-005		RC-9120-075	
60	Track Clamp Support (Long)	1	RC-906-AS		RC-906-A	
61	Wheel Axle, with Wheel Spacer(s)	4	RC-9110-0025		RC-9110-015	
62	Bearing	8	RC-9107-0025		RC-9107-015	
62A	Bearing Cone	8	---			
62B	Bearing Cup	8	---			
63	Adjustable Bearing Nut	4	---			
64	Bottom Block Guard	2	---		RC-9688-015	
65	Hook Latch	1	RH/L-10-90045		RH/L-10-90063	
66	Idler Sheave with Bearing	2	---		RC-9656-020	
67	Idler Sheave Bushing for item 66	2	---		RC-9653-020	
68	Bottom Cross Head	1	---		RC-9684-015	
69*	Gear and Handwheel Cover Screw	8	R999			
70*	Hand Chain Guide Screw	8	R44-.25-.50			
71*	Decal-Handwheel Cover	1	RC-947-C			
72*	Decal-Gear Cover	1	RC-947-D			
73*	Warning Tag	1	RC-947-E			
74*	Warning Tag-Handwheel	1	RC-947-H			
75*	Pawl Spacer	1	RC-973-005			
76*	Capacity Label	1	71110811			
77*	Serial Number Tag	1	71106223			
78*	Ingersoll-Rand Logo Label	1	71106256			
79*	Warning Tag	1	71038863			

\* Not shown on drawing

**ULM2S 3 to 6 ton HOIST PARTS LIST (cont'd)**

Item No.	Description of Part	Qty Total	Part Number		
			3	4	5 & 6
43	Geared Trolley Wheel	2	RC-9108-030		
44	Geared Trolley Side Plate	2	RC-9683-G-030		
45	Dead End Bale	-	RC-9293-030	RC-9293-050	
46	Dead End Stud	-	RC-689-030	RC-689-050	
47	Plain Trolley Wheel, Geared Unit Qty. - ( )	4(2)	RC-9109-030		
48	Load Chain	2	LC3805A		
	Load Chain (Zinc Plated)		LC3805AZP		
49	Plain Trolley Side Plate Geared Unit Qty. - ( )	4 (2)	RC-9683-030	RC-9683-050	
50	Track Clamp Side Plate	2	RSTTC-153-B-030	RSTTC-153-B-005	
51	Track Clamp Screw Support (Short)	1	---		
52	Track Clamp Guide Pin	1	RSTTC-152-030	RSTTC-152-005	
53	Track Clamp Screw	1	RSTTC-151-030	RSTTC-151-005	
54	Cross Piece	2	RC-9684-030	RC-9684-050	
55	Track Clamp Jaw (Pair)	1	RSTTC-150-030	RSTTC-150-050	
56	Track Clamp Hand Chain	1	RC-937		
57	Track Clamp Handwheel Swinging Guard	1	RC-9121-0075		
58	Track Clamp Screw Retainer Ring	1	R5100-87		
59	Track Clamp Handwheel	1	RC-9120-075		
60	Track Clamp Support (Long)	1	---		
61	Wheel Axle, with Wheel Spacer(s)	4	RC-9110-030	RC-510-2	
62	Bearing	8	---		
62A	Bearing Cone	8	RC-9116-030		
62B	Bearing Cup	8	RC-9117-030		
63	Adjustable Bearing Nut	4	RC-9112-030		
64	Bottom Block Guard	2	RC-9688-015		
65	Hook Latch	1	RH/L-10-90081	RH/L-10-90107	
66	Idler Sheave with Bearing	2	RC-9656-020	RC-9656-050	
67	Idler Sheave Bushing for item 66	2	RC-9653-020	RC-9653-050	
68	Bottom Cross Head	1	RC-9652-030	RC-9652-040	RC-9652-050
69*	Gear and Handwheel Cover Screw	8	R999		
70*	Hand Chain Guide Screw	8	R44-.25-.50		
71*	Decal-Handwheel Cover	1	RC-947-C		
72*	Decal-Gear Cover	1	RC-947-D		
73*	Warning Tag	1	RC-947-E		
74*	Warning Tag-Handwheel	1	RC-947-H		
75*	Pawl Spacer	1	RC-973-015		
76*	Capacity Label	1	71110811		
77*	Serial Number Tag	1	71106223		
78*	Ingersoll-Rand Logo Label	1	71106256		
79*	Warning Tag	1	71038863		

\* Not shown on drawing

## ACCESSORIES

Description	Part No.
Orange Touch-Up Paint	MHD-OR
Chain Lubricant	LUBRI-Link

## PARTS ORDERING INFORMATION

The use of replacement parts other than INGERSOLL-RAND Material Handling will invalidate the Company's warranty. For prompt service and genuine INGERSOLL-RAND Material Handling parts provide your nearest Distributor with the following:

1. Complete model number as it appears on the name plate: ULM2S plus capacity.
2. Part number and part name as shown in manual.
3. Quantity required.

The serial number of each hoist may be found on the nameplate mounted on the side plate.

If this serial number plate has been removed or defaced, give size and type of I-beam on which the hoist operates, since each hoist is build for one specific size only.

<b>INGERSOLL-RAND</b> MATERIAL HANDLING		<b>MANUAL</b>	
		<b>CHAIN HOIST</b>	
MODEL NUMBER	<input type="text"/>		
SERIAL NUMBER	<input type="text"/>	NO. CHAIN FALLS	<input type="text"/>
MAX. LIFT CAPACITY	<input type="text"/>	lbs.	
71106223			

For your convenience and future reference it is recommended that the following information be recorded.

**Hoist Model Number**.....

**Hoist Serial Number**.....

**Date Purchased**.....

### Return Goods Policy

INGERSOLL-RAND will not accept any returned goods for warranty or service work unless prior arrangements have been made and written authorization has been provided from the location where the goods were purchased.

Hoists returned with opened, bent or twisted hooks, or without chain and hooks, will not be repaired or replaced under warranty.

## NOTICE

- **Continuing improvement and advancement of design may cause changes to this hoist which are not included in this manual. Manuals are periodically revised to incorporate changes. Always check the manual edition number on the front cover for the latest issue.**
- **If your hoist has special finish requirements for painted parts, please specify when ordering.**

When the life of the hoist has expired, it is recommended that the hoist be disassembled, degreased and parts separated as to materials so that they may be recycled. For additional information contact:

### Ingersoll-Rand Material Handling

2724 Sixth Avenue South  
Seattle, Wa 98124 USA

Phone: (206) 624-0466

Fax: (206) 624-6265

or

### Ingersoll-Rand International Sales

### Ingersoll-Rand Material Handling

### Samiia, Douai Operations

111, avenue Roger Salengro

59450 Douai, France

Phone: (33) 27-93-08-08

Fax: (33) 27-93-08-00

## HOIST AND WINCH LIMITED WARRANTY

Ingersoll-Rand Company (I-R) warrants to the original user its Hoists and Winches (Products) to be free of defects in material and workmanship for a period of one year from the date of purchase. I-R will repair, without cost, any Product found to be defective, including parts and labor charges, or at its option, will replace such Products or refund the purchase price less a reasonable allowance for depreciation, in exchange for the Product. Repairs or replacements are warranted for the remainder of the original warranty period.

If any Product proves defective within its original one year warranty period, it should be returned to any Authorized Hoist and Winch Service Distributor, transportation prepaid with proof of purchase or warranty card.

This warranty does not apply to Products which I-R has determined to have been misused or abused, improperly maintained by the user, or where the malfunction or defect can be attributed to the use of non-genuine I-R parts.

**I-R makes no other warranty, and all implied warranties including any warranty of merchantability or fitness for a particular purpose are limited to the duration of the expressed warranty period as set forth above. I-R's maximum liability is limited to the purchase price of the Product and in no event shall I-R be liable for any consequential, indirect, incidental, or special damages of any nature rising from the sale or use of the Product, whether based on contract, tort, or otherwise.**

**Note:** Some states do not allow limitations on incidental or consequential damages or how long an implied warranty lasts so that the above limitations may not apply to you.

This warranty gives you specific legal rights and you may also have other rights which may vary from state to state.

## IMPORTANT NOTICE

It is our policy to promote safe delivery of all orders.

*This shipment has been thoroughly checked, packed and inspected before leaving our plant and receipt for it in good condition has been received from the carrier. Any loss or damage which occurs to this shipment while enroute is not due to any action or conduct of the manufacturer.*

### **VISIBLE LOSS OR DAMAGE**

If any of the goods called for on the bill of lading or express receipt are damaged or the quantity is short, do not accept them until the freight or express agent makes an appropriate notation on your freight bill or express receipt.

### **CONCEALED LOSS OR DAMAGE**

When a shipment has been delivered to you in

apparent good condition, but upon opening the crate or container, loss or damage has taken place *while in transit, notify the carrier's agent immediately.*

### **DAMAGE CLAIMS**

You must file claims for damage with the carrier. It is the transportation company's responsibility to reimburse you for repair or replacement of goods damaged in shipment. Claims for loss or damage in shipment must not be deducted from the Ingersoll-Rand invoice, nor should payment of Ingersoll-Rand invoice be withheld awaiting adjustment of such claims as the carrier guarantees safe delivery. You may return products damaged in shipment to us for repair, which services will be for your account and form your basis for claim against the carrier.

## United States Office Locations

### For Order Entry and Order Status:

#### Ingersoll-Rand Distribution Center

510 Hester Drive  
P.O. Box 618  
White House, TN 37188  
Phone: (615) 672-0321  
Telex: 786573  
Fax: (615) 672-0801

#### Ingersoll-Rand Material Handling Technical Support

2724 Sixth Avenue South  
P.O. Box 24046  
Seattle, WA 98124-0046  
Phone: (206) 624-0466  
Telex: 328795  
Fax: (206) 624-6265

#### Regional Sales Offices

##### Atlanta, GA

111 Ingersoll-Rand Drive  
Chamblee, GA 30341  
Phone: (404) 936-6230

##### Detroit, MI

23192 Commerce Drive  
Farmington Hills, MI 48335  
Phone: (313) 476-6677  
Fax: (313) 476-6670

##### Houston, TX

2500 East T.C. Jester  
Suite 150  
Houston, TX 77008  
Phone: (713) 864-3700

##### Los Angeles, CA

5533 East Olympic Blvd.  
Los Angeles, CA 90022  
Phone: (213) 725-2826

##### Milwaukee, WI

12311 W. Silver Spring Dr.  
Milwaukee, WI 53225  
Phone: (414) 461-0973

##### Philadelphia, PA

900 E. 8th Ave., Suite 103  
P.O. Box 425  
King of Prussia, PA 19406  
Phone: (215) 337-5930

## International

Offices and distributors in principal cities throughout the world. Contact the nearest Ingersoll-Rand office for the name and address of the distributor in your country or write/fax to:

Ingersoll-Rand  
Material Handling  
P.O. Box 24046 Seattle,  
WA 98124-0046 USA  
Phone: (206) 624-0466  
Telex: 328795  
Fax: (206) 624-6265

### Canada

#### National Sales Office Regional Warehouse

##### Toronto, Ontario

51 Worcester Road  
Rexdale, Ontario  
M9W 4K2  
Phone: (416) 675-5611  
Fax: (416) 675-6920

#### Regional Sales Offices

##### Calgary, Alberta

333 11th Avenue S.W.  
Calgary, Alberta  
T2R 0C7  
Phone: (403) 261-8652

##### Montreal, Quebec

3501 St. Charles Blvd.  
Kirkland, Quebec  
H9H 4S3  
Phone: (514) 695-9040

##### British Columbia

201-6351 Westminster Hwy  
Richmond, B.C.  
V7C 5C7  
Phone: (604) 278-0459

#### British Columbia Regional Warehouse Technical Support

123 Bowser Avenue  
North Vancouver, British  
Columbia V7P 3H1  
Phone: (604) 985-4470  
Fax: (604) 985-0160

### Latin America Operations

#### Ingersoll-Rand Production Equipment Group

730 N.W. 107 Avenue  
Suite 300, Miami, FL  
33172-3107  
Phone: (305) 559-0500  
Telex: 441617TLS UI  
Fax: (305) 559-7505

### Europe, Middle East and Africa

#### Ingersoll-Rand

#### Material Handling

#### Samiia, Douai Operations

111, avenue Roger Salengro  
59450 Douai, France  
Phone: (33) 27-93-08-08  
Fax: (33) 27-93-08-00

### Asia - Pacific

#### Ingersoll-Rand (Japan) Ltd.

Kowa Bldg. No. 17  
2-7 Nishi-Azabu 1-chome  
Minato-ku, Tokyo 106,  
Japan  
Phone: (03) 3403-0641/7  
Fax: 81 3 3401-2049