

# OPERATION AND MAINTENANCE MANUAL

for

## 1/2 to 10 TON\* TROLLEY MODELS

### PLAIN TROLLEYS

TVP005 1/2 TON	TVP010 1 TON	TVP020 2 TON
TVP030 3 TON	TVP050 5 TON	TVP100 10 TON

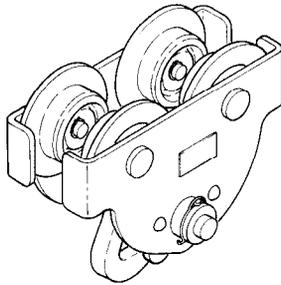

1/2 to 5 ton, Plain

### GEARED TROLLEYS

TVG010 1 TON	TVG020 2 TON	TVG030 3 TON
TVG050 5 TON	TVG100 10 TON	

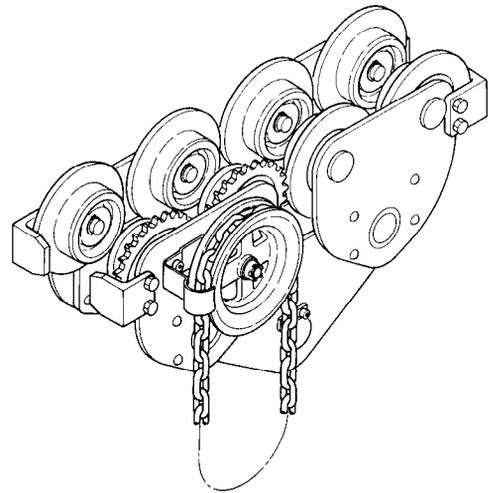

10 ton, Geared

\*Tons in this manual are metric tons (2,200 lbs.)

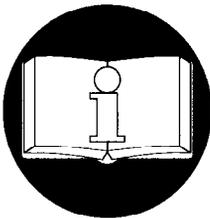

**READ THIS MANUAL BEFORE USING THESE PRODUCTS.** This manual contains important safety, installation, operation and maintenance information. Make this manual available to all persons responsible for the operation, installation and maintenance of these products.

### **⚠ WARNING**

Do not use this trolley for lifting, supporting, or transporting people or lifting or supporting loads over people.

Always operate, inspect and maintain this trolley in accordance with American National Standards Institute Safety Code (B30.16) and any other applicable safety codes or regulations.

Refer all communications to the nearest Ingersoll-Rand Material Handling Products Office or Distributor.

Form MHD56060

Edition 1

September 1992

71104574

© 1992 Ingersoll-Rand Company

**INGERSOLL-RAND®**  
**MATERIAL HANDLING**

## SAFETY INFORMATION

This manual provides important information for all personnel involved with the safe installation, operation and proper maintenance of this product. Even if you feel you are familiar with this or similar equipment, you must read and understand this manual before operating the product.

### Danger, Warning, Caution and Notice

Throughout this manual there are steps and procedures which, if not followed, may result in a hazard. The following signal words are used to identify the level of potential hazard.

#### DANGER

Danger is used to indicate the presence of a hazard which *will* cause *severe* personal injury, death, or substantial property damage if the warning is ignored.

#### WARNING

Warning is used to indicate the presence of a hazard which *can* cause *severe* personal injury, death, or substantial property damage if the warning is ignored.

#### CAUTION

Caution is used to indicate the presence of a hazard which *will* or *can* cause *minor* personal injury or property damage if the warning is ignored.

#### NOTICE

Notice is used to notify people of installation, operation, or maintenance information which is important but not hazard-related.

### Safety Summary

#### WARNING

- Do not use this trolley or attached equipment for lifting, supporting, or transporting people or lifting or supporting loads over people.
- The supporting structures and load-attaching devices used in conjunction with this trolley must provide an adequate safety factor to handle the rated load, plus the weight of the trolley and attached equipment. This is the customer's responsibility. If in doubt, consult a qualified structural engineer.

The National Safety Council, Accident Prevention Manual for Industrial Operations, Eighth Edition and other recognized safety sources make a common point: Employees who work near cranes or assist in hooking on or arranging a load should be instructed to keep out from under the load. From a safety standpoint, one factor is paramount: conduct all lifting or pulling operations in such a manner that if there were an equipment failure, no personnel would be injured. This means keep out from under a raised load and keep out of the line of force of any load.

To our interpretation, INGERSOLL-RAND Material Handling trolleys are manufactured in accordance with the latest ASME standards.

However, contrary to common belief, the Occupational Safety and Health Act of 1970, as we understand it, generally places the burden of compliance with the user, not the manufacturer. Many OSHA requirements are not concerned or connected with the manufactured product but are, rather, connected with the final installation: "It is the owner's responsibility and user's responsibility to determine the suitability of a product for any particular use. Check all applicable industry, trade association, federal, state and local regulations. Read all operating instructions and warnings before operation".

**Rigging:** It is the responsibility of the operator to exercise caution, use common sense and be familiar with proper rigging techniques. See ANSI/ASME B30.9 for rigging information, American National Standards Institute, 1430 Broadway, New York, NY 10018.

#### NOTICE

- INGERSOLL-RAND Replacement Parts are specifically designed to ensure optimum performance of your equipment. Use of other than genuine INGERSOLL-RAND Material Handling parts may adversely affect safe operation and will invalidate the warranty.

## SAFE OPERATING INSTRUCTIONS

The following warnings and operating instructions have been adapted in part from American National (Safety) Standard ASME B30.16 (Overhead Hoists) and are intended to avoid unsafe operating practices which might lead to personal injury or property damage.

**INGERSOLL-RAND** recognizes that most companies who use hoists and trolleys have a safety program in force at their facility. In the event that some conflict exists between a rule set forth in this publication and a similar rule already set by an individual company, the more stringent of the two should take precedence.

Safe Operating Instructions are provided to make an operator aware of dangerous practices to avoid and are not necessarily limited to the following list. Refer to specific sections in the manual for additional safety information.

If this trolley is used in conjunction with a hoist, also refer to the hoist manual for additional precautions and instructions.

1. Only allow qualified people (trained in safety and operation) to operate the trolley.
2. Only operate a trolley if you are physically fit to do so.
3. When a "DO NOT OPERATE" sign is placed on the trolley, do not operate the trolley until the sign has been removed by designated personnel.
4. Before each shift, the operator should inspect the trolley for wear or damage.
5. Never use a trolley that inspection indicates is defective.
6. Periodically, inspect the trolley thoroughly and replace worn or damaged parts.
7. Lubricate the trolley regularly.
8. Never splice a hand chain by inserting a bolt between links.
9. Only attach a hoist having a rated capacity equal to or less than the capacity of the trolley.
10. Only lift loads less than or equal to the rated capacity of the hoist.
11. When using two hoists to suspend one load, select two trolleys each having a rated capacity equal to or more than the load. This provides adequate safety in the event of a sudden load shift or failure of one trolley.
12. Never place your hand inside the throat area of a hook.
13. Never use the hand chain to support a load.
14. Only operate a trolley when the load is centered under the trolley. Do not "side pull" or "yard."
15. Pay attention to the load at all times when operating the trolley.
16. Make sure all people are clear of the load path. Do not lift a load over people.
17. Never use the trolley for lifting or lowering people, and never allow anyone to stand on a suspended load.
18. Do not swing a suspended load.
19. Never suspend a load for an extended period of time.
20. Never leave a suspended load unattended.
21. Never weld or cut a load suspended by the trolley.
22. Never use the trolley hand chain as a welding electrode.
23. Do not operate the trolley hand chain if excessive noise, jamming, overloading, or binding occurs.
24. Always rig the load properly and carefully.
25. Remove all loads before performing any maintenance.
26. Avoid collision or bumping of trolley.
27. After use, properly secure trolley and all loads.

## WARNING LABEL

### NOTICE

- Trolley warning label is located on side plate.

Each trolley is supplied from the factory with the warning label shown. If the label is not attached to your unit, order a new label and install it. See the parts list for the part number. Label may not be shown actual size.



## SPECIFICATIONS

Trolley Model No.		Capacity (metric tons)*	Min. curve radius		Flange Range (Width)		Net Weight	
Plain	Geared		in	mm	in	mm	lbs	kg
TVP005	---	1/2	35	900	2 - 5	50 - 125	13	6
TVP010	TVG010	1	51	1300	2.5 - 5	60 - 125	22 / 30	10 / 14
TVP020	TVG020	2	59	1500	3 - 6	75 - 150	42 / 53	19 / 24
TVP030	TVG030	3	79	2000	3.5 - 6.5	90 - 170	57 / 74	26 / 33.5
TVP050	TVG050	5	102	2600	4 - 7	100 - 175	97 / 117	44 / 53.5
TVP100	TVG100	10	**	**	6 - 7	130 - 175	211 / 222	96 / 100

\* 1 metric ton = 1000 kg = 2,200 lbs.

\*\* Not recommended for curved beams.

# INSTALLATION

## ⚠ WARNING

- Before installing, read "SAFETY INFORMATION."
- To avoid an unbalanced load which may damage the trolley, the hoist must be centered under the trolley.

## NOTICE

- Install the manual chain hoist so that the hoist hand chain is on the opposite side of the trolley hand chain.
- Trolley wheels ride on the top of the lower flange of the beam.
- During installation and repair assembly/disassembly steps visually inspect components for distortion, wear and damage. Replace any item indicating damage, distortion and/or excessive wear.
- Proper use, inspections and maintenance will increase the life and usefulness of your INGERSOLL-RAND equipment. During assembly lubricate gears, nuts, bolts and all machined threads with applicable lubricants. Use of antisieze compound and/or thread lubricant on capscrew and nut threaded areas prevents corrosion and allows for ease of disassembly of component.

### 1/2 to 5 ton Trolley Installation

(Reference: Parts Dwg. MHTPA0274)

Pre-adjust trolley width for the beam flange measurement of Table 1 using Dwg. MHTPA0350 as a guide. The trolley must be installed from underneath the beam using the following procedure.

1. Calculate dimensions "A" and "B" using Table 1 and Dwg. MHTPA0350 for guidance.
2. Install suspender shaft (5) into threaded sideplate (7) by turning in a clockwise direction until dimension "A" is reached.

**TABLE 1**

1/2 to 5 ton Trolley Suspender Adjustment Guide				
Size (ton)	Track Size (mm)		Dimension Adjustment Calculation (mm)	
	W		A	B
	Min.	Max.		
1/2	50	125	$(W+13) \times 1/2$	$125 - W$
1	60	125	$(W+13) \times 1/2$	$125 - W$
2	75	155	$(W+14) \times 1/2$	$155 - W$
3	90	170	$(W+17) \times 1/2$	$170 - W$
5	100	175	$(W+12) \times 1/2$	$175 - W$

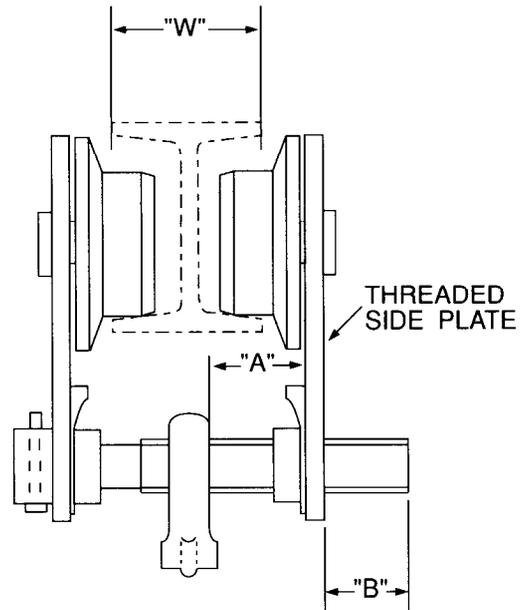

(Dwg. MHTPA0350)

## NOTICE

- Dimension "A" is measured from the inside face of side plate (7) to end of the threads on suspender shaft (5). **DO NOT** include non-threaded portion of suspender shaft in measurement of dimension "A".
3. Place suspender (6) at beginning of threads on suspender shaft (5).
  4. Hold suspender (6) to maintain distance between suspender and threaded side plate (7). Rotate suspender shaft (5) **clockwise** until dimension "B" is obtained. Adjust to ensure suspender shaft (5) hole vertically aligns with hole in plain (11) or geared (21) side plate shaft sleeve.
  5. Place assembled portion of trolley on beam. Place plain (11) or geared (21) side plate on beam and guide suspender shaft (5) through side plate shaft sleeve.
  6. Insert shaft stopper pin (10) through side plate sleeve and suspender shaft (5). Install pin retainer (9) to lock shaft stopper pin (10) in place.
  7. Check total clearance between beam and trolley wheel flanges.

## NOTICE

- The total clearance between the beam and the trolley wheel flanges is 3/32 to 5/32 inches (2 to 4 mm) when trolley is installed correctly. See Dwg. MHTPA0342, the difference between dimensions "X" and "Y" equals the total clearance.
8. Upon completion of installation, conduct initial operating checks as described in the "OPERATION" section.

## 10 Ton Trolley Installation

(Reference: Parts Dwg. MHTPC0275)

The 10 ton trolley assembly consists of 4 sideplate assemblies, 2 shafts, 2 hanging plates and the suspender pin. The following procedure details the steps required to install and adjust the trolley to ensure safe operation.

### ⚠ WARNING

• Depending on the size you select, the trolley alone may weigh more than 222 lbs (101 kg). If parts of the trolley or hoist are dropped, they can injure personnel or damage property. Adequately support the trolley when lifting into place on the beam.

• To avoid an unbalanced load, which may cause personnel injury and damage, the suspender pin (33) must be centered under the trolley by the spacers (26) to ensure the attached hoist will be centered when installed.

Pre-adjust trolley width using the "Spacer to Beam Track Width Chart" (Table 2).

The trolley must be installed from underneath the beam using the following procedure.

1. Remove nut (24), washers (25) and adjusting spacers (26) from shaft (27).
2. Insert shaft (27) into side plate (11) for plain wheels, or side plate (21) for geared wheels. Align shaft and side plate (11 or 21) holes. Install capscrew (29) and nut (38) to lock shaft (27) in place.
3. Install spacers (26) on shafts (27) [if required].
4. Install a hanging plate (31).
5. Slide collars (32) over shafts (27).
6. Install remaining hanging plate (31).
7. Install spacers on shafts (27) [if required].

TABLE 2

10 Ton Trolley Spacer to Beam Track Width Chart						
Track Width	in	5.9	6	6.4	6.7	7
	mm	150	156	163	169	175
Spacers required between side plates and hanging plates.		0	1	2	3	4
Spacers required on outside of side plates.		8	6	4	2	0

### ⚠ CAUTION

• Spacers (26) must be installed to both sides in equal amounts to ensure the suspender pin (33) is properly centered. Spacers (26) not used between the side plates (11 or 21) and the hanging plates (31) are to be installed outside the side plates (11) and secured in place by nut (24).

8. Adequately support the assembled portion of Trolley in place on beam flange.
9. Slide remaining side plates (11) over shafts (27). Push all plates together.
10. Slide remaining spacers (26) over the end of the shafts and install washers (25) and nuts (24).

### ⚠ CAUTION

• The nuts (24), washers (25) and spacers (26) must firmly hold the trolley. If the side plates can be spread further apart, install additional spacers as necessary between side plates (11) and washers (25). Secure in place with nuts (24).

11. Install suspender pin (33). Secure in place with keys (34) and capscrews (35).
12. Check total clearance between beam and trolley wheel flanges.

### ⚠ CAUTION

• The total clearance between the beam and the trolley wheel flanges is 3/32 to 5/32 inches (2 to 4 mm) when trolley is installed correctly. As shown in Dwg. MHTPA0342, the difference between dimensions "X" and "Y" equals the total clearance.

13. Upon completion of installation, conduct initial operating checks as described in the "OPERATION" section of this manual.

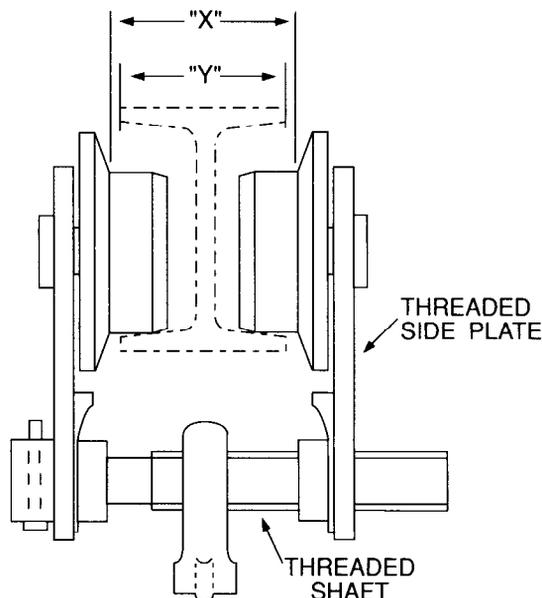

(Dwg. MHTPA0342)

## OPERATION

The four most important aspects of trolley operation are:

1. Follow all safety instructions when operating trolley.
2. Allow only qualified people to operate a trolley.
3. Subject each trolley to regular inspections and a scheduled maintenance program.
4. Be aware of the hoist and trolley capacity and weight of load at all times. Do not overload.

### **⚠ WARNING**

• **Severe injury can be caused by: 1) falling under a moving load, 2) being caught between a moving load and an object, 3) tripping over an unseen object. To avoid injury, push to move the trolley, do not pull. Pushing will allow you to stay out of the path of the load and also look in the direction you are moving.**

### Initial Operating Checks

1. After trolley installation ensure the side plates are vertical.
2. With hoist installed, verify that hoist is centered below trolley.
3. Raise a load equal to the lower of the rated capacities of either the trolley or hoist a few inches (cm) off the floor.
4. Operate the trolley along the entire length of the beam.
5. Inspect trolley performance when raising, moving and lowering test load(s). Trolley must operate smoothly prior to being placed in service for general use.

### Plain Trolley (1/2 to 10 ton)

1. To move an unloaded hoist/trolley, push on the hoist load chain.
2. To move a loaded hoist/trolley, push on the load or the hoist load hook shank.

### Geared Trolley (1 to 10 ton)

(Ref. Dwg. MHTPA0100)

1. When facing the trolley hand wheel:
  - a. Pull down on right side of hand chain (Clockwise rotation) to move left.
  - b. Pull down on left side of hand chain (Counterclockwise rotation) to move right.

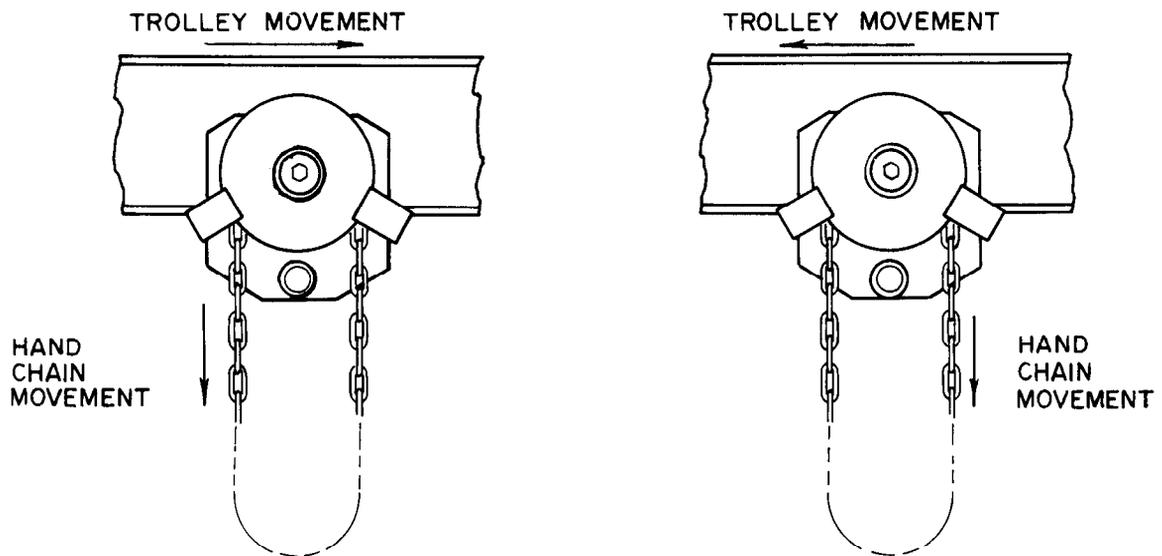

(Dwg. MHTPA0100)

There are two types of inspection: the frequent inspection performed by the operator and periodic inspections performed by qualified personnel.

Careful inspection on a regular basis will reveal potentially dangerous conditions while still in the early stages, allowing corrective action to be taken before the condition becomes dangerous.

Any deficiency revealed through inspection must be reported to an appointed person. A determination must be made as to whether a deficiency constitutes a safety hazard before resuming operation of the trolley or hoist.

### Records and Reports

Some form of inspection record should be maintained for each trolley, listing all points requiring periodic inspection. A written report should be made quarterly on the condition of the critical parts (e.g. wheels, bearings, gears, side plates and hoist suspender) of each trolley. These reports should be dated, signed by the person who performed the inspection, and kept on file where they are readily available to authorized personnel.

## NOTICE

**• During assembly/disassembly visually inspect each component for distortion, wear and damage. Replace items indicating damage, distortion and/or excessive wear. Proper use, inspections and maintenance will increase the life and usefulness of your INGERSOLL-RAND equipment.**

### Frequent Inspection

On trolleys in continuous service, frequent inspection should be made at the beginning of each shift. In addition, visual inspections should be conducted during regular service for any damage or evidence of malfunction.

1. **OPERATION.** Operate the trolley so that it travels a few feet (1 meter). During the few feet (1 meter) of travel, check for visual signs or abnormal noises which could indicate a defect. Check for smooth operation. Do not operate the trolley until all defects have been corrected.

### Periodic Inspection

According to ASME B30.16 (Overhead Hoists), frequency of periodic inspection depends on the severity of usage:

<b>NORMAL</b>	<b>HEAVY</b>	<b>SEVERE</b>
yearly	semi-annually	quarterly

Disassembly may be required for HEAVY or SEVERE usage. Keep accumulative written records of periodic inspections to provide a basis for continuing evaluation. Inspect all the items in "Frequent Inspection." Also inspect the following:

1. **FASTENERS.** Check retainer rings, split pins, cap-screws and nuts. Replace if missing or damaged and tighten if loose.
2. **ALL COMPONENTS.** Inspect for wear, damage, distortion, deformation and cleanliness. If external evidence indicates the need, disassemble. Check gears, shafts, bearings, and chain guides. Replace worn or damaged parts. Clean, lubricate and reassemble.
3. **HAND CHAIN WHEEL.** Check for damage or excessive wear. Replace if necessary.
4. **SUPPORTING STRUCTURE.** Check for distortion, wear and continued ability to support load.
5. **TROLLEY.** Check that the trolley wheels track the beam properly and total clearance between wheels and beam equals 3/32 to 5/32 in. (2 to 4 mm). Check side plates for spreading due to bending. Repair as necessary.
6. **LABELS.** Check for presence and legibility. Replace if necessary.

### Trolleys Not in Regular Use

A trolley which has been idle for a period of one month or more, but less than six months, shall be given an inspection conforming with the requirements of "Frequent Inspection".

A trolley which has been idle for a period of over six months shall be given a complete inspection conforming with the requirements of "Periodic Inspection". Standby trolleys shall be inspected at least semi-annually in accordance with the requirements of "Frequent Inspection". If abnormal operating conditions apply trolleys may require more frequent inspections.

## NOTICE

• **Proper use, inspections and maintenance will increase the life and usefulness of your INGERSOLL-RAND equipment. During assembly lubricate gears, nuts, bolts and all machined threads with applicable lubricants. Use of antisieze compound and/or thread lubricant on capscrew and nut threaded areas prevents corrosion and allows for ease of disassembly of component.**

### Trolley Wheel Shafts

During assembly lubricate trolley wheel shafts and bearing housings with an antisieze compound or thread lubricant as applicable to prevent corrosion.

### Hand Chain

Hand chain, used on geared trolleys, normally requires no lubrication.

### Pinion Shaft

Lubricate pinion shaft before installing in geared side plate (21) shaft sleeve. For temperatures -20° to 50° F (-29° to 10° C) use EP 1 grease or equivalent. For temperatures 30° to 120° F (-1° to 49° C) use EP 2 grease or equivalent.

## ⚠ CAUTION

• **When greasing pinion and geared wheels make sure excess grease is cleaned off of trolley wheel riding surface and track of beam. Failure to keep track and wheel contact surfaces clean could affect the safe operation of the trolley.**

### Geared Trolley Wheels

Lubricate exposed trolley drive pinion and wheel teeth. Brush with grease as often as necessary to keep teeth liberally covered. If the grease becomes contaminated with sand, dirt or other abrasive materials, clean off old grease and brush on new. For temperatures -20° to 50° F (-29° to 10° C) use EP 1 grease or equivalent. For temperatures 30° to 120° F (-1° to 49° C) use EP 2 grease or equivalent.

## TROUBLESHOOTING

During all rigging and transporting situations the single most important point to keep in mind is **SAFETY**. Any uncorrected abnormal condition may result in personnel injury, death or property damage. At the first indication of a change in normal trolley operation conduct the following: (1) **stop** all operations on the affected trolley, (2) properly **secure** the trolley, and (3) **investigate** to determine the cause of the change in operation. The chart below provides a brief guide to common trolley problems, probable causes and solutions.

PROBLEM	CAUSE	SOLUTION
Trolley will not operate.	Trolley is overloaded.	Reduce load to within rated capacity.
	Trolley wheel bearings are damaged.	Replace trolley wheel bearings. *
Trolley won't stop or trolley wheels slip.	Too much oil or grease on track of beam and wheels.	Clean track and trolley wheels.
Hand Chain operation difficult / impossible.	Twisted chain.	Untwist chain. *
	Hand Wheel damaged.	Replace Hand Wheel. *
	Pinion Shaft damaged.	Replace Pinion Shaft. *
	Geared Wheel(s) damaged.	Replace Geared Wheel(s). *
Suspender does not automatically adjust to load shifts.	Suspender/Suspender Shaft threads dirty.	Clean threads.
	Suspender/Suspender Shaft threads damaged.	Repair or replace suspender and/or suspender shaft.

\* Procedure provided in "MAINTENANCE" section.

**⚠ WARNING**

- Never perform maintenance on the trolley while it is supporting a load. A falling load can cause injury or death of personnel and damage to property.
- Before starting maintenance, tag trolley:  
**DANGER - DO NOT OPERATE - EQUIPMENT BEING REPAIRED.**
- Only allow qualified service personnel to perform maintenance.
- After performing maintenance, test trolley to 150% of its rated capacity (or to that amount required by the applicable regulations) before returning to service.

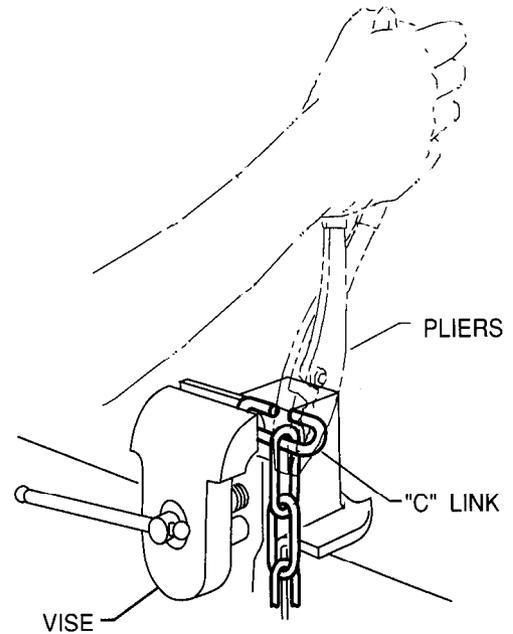

(Dwg. MHTPA0014)

**Hand Chain Adjustment or Replacement**

**⚠ CAUTION**

- When cutting the weld side of a hand chain link, do not cut or nick the opposite side. A damaged link must be replaced to prevent premature failure. A falling hand chain can injure personnel.

**NOTICE**

• Proper use, inspections and maintenance will increase the life and usefulness of your INGERSOLL-RAND equipment. During assembly lubricate gears, nuts, bolts and all machined threads with applicable lubricants. Use of antisieze compound and/or thread lubricant on capscrew and nut threaded areas prevents corrosion and allows for ease of disassembly of component.

1. To create a "C" link, cut the welded side of the link with a hack saw. Clamp one side of the "C" link in a vise and bend it open by using pliers to grip the exposed part of the link.
2. If you are replacing the hand chain, disconnect it at the "C" link and carefully remove the hand chain.

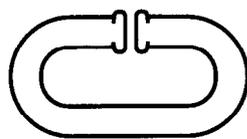

"C" Link

(Dwg. MHTPA0016)

3. **To replace chain:**
  - a. Cut a length of chain 2 times the required hand chain drop plus 1 foot (30 cm).
  - b. Run the new chain up through the left hand chain guide, around the hand wheel, making sure the hand chain is seated in the hand wheel pockets, and back down through the right hand chain guide.
4. **To adjust chain length:**
  - a. Add or remove a length of chain 2 times the desired amount of chain adjustment.

**NOTICE**

• To prevent the hand chain from twisting maintain an even number of links. (Ref. Dwg. MHTPA0015)

5. Connect the hand chain ends with the "C" link(s), make the total number of links even, and bend the "C" link(s) shut.
6. Make sure the hand chain is not twisted. To untwist, open a "C" link and remove one hand chain link.

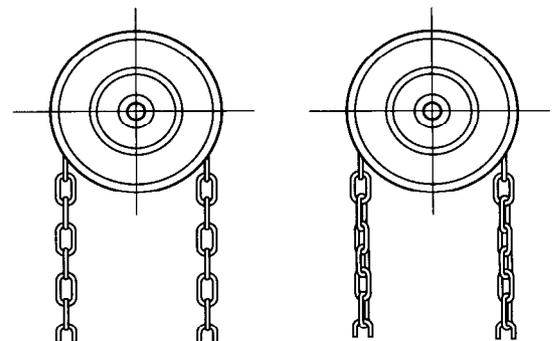

UNTWISTED

TWISTED

(Dwg. MHTPA0015)

## Disassembly Procedures

### NOTICE

- **Prior to disassembly record the following: suspender and suspender shaft Dimension "A" and "B" for 1/2 to 5 ton trolleys; the number of spacers between side plates and hanging plates on the 10 ton trolley.**

- **1/2 ton trolleys are only available as plain trolleys. Procedures listed for geared trolley do not apply to the 1/2 ton unit.**

- **During maintenance assembly/disassembly visually inspect components for distortion, wear and damage. Replace any item indicating damage, distortion and/or excessive wear.**

### CAUTION

- **Observe proper safety precautions when conducting maintenance on or around trolleys. It is recommended that trolley be removed from beam and moved to a safe work area.**

- **Depending on the size you select, the trolley alone may weigh more than 222 lbs (101 kg). If parts of the trolley or hoist are dropped, they can injure personnel or damage property. Adequately support the hoist and trolley when lifting or removing them from the beam.**

### 1 to 10 ton Geared Trolley Hand Wheel Disassembly

This section details the disassembly of the geared trolley hand wheel.

1. Remove split pin (23) from pinion shaft (14).

### NOTICE

- **Discard split pin (23). Do not reuse a bent split pin. During reassembly install a new split pin (23).**

2. Remove nut (19) and washer (22) from pinion shaft (14).
3. Remove hand wheel (17) from pinion shaft (14).
4. Remove chain guide (16) from geared sideplate (21) by removing 2 capscrews (20).

### NOTICE

- **Do not remove pinion shaft (14) unless necessary to repair, replace or inspect.**

5. To remove the pinion shaft gently tap on shaft head with a soft mallet to loosen. Slide pinion shaft (14) out of side plate (21) pinion sleeve.

### 1/2 to 5 ton Trolley Disassembly

This section details the disassembly of the 1/2 to 5 ton trolley assembly.

1. Remove pin retainer (9).
2. Remove shaft stopper pin (10).
3. Remove side plate (11 or 21) by sliding along suspender shaft (5).
4. Remove suspender (6) from suspender shaft (5) by turning counter-clockwise.

### NOTICE

- **Record number of turns required to remove suspender (6) and suspender shaft (5). Note Table 1 dimensions "A" and "B" in the "INSTALLATION" section for use during re-installation.**

- **During disassembly, repair, inspection and re-installation periods be careful not to damage threads on suspender shaft (5), suspender (6) or threaded side plate (7). When removed, wrap suspender shaft (5) with protective material to prevent damage to threads. To prevent galling of threads make sure threaded areas are clean, show no indication of thread burrs or flat spots and are lightly coated with an applicable thread lubricant prior to assembly of parts.**

5. Remove suspender shaft (5) from threaded side plate (7) by turning shaft counter-clockwise.

### NOTICE

- **To re-install 1/2 to 5 ton trolley suspender shaft (5) in side plate (7) and suspender (6) on suspender shaft turn clockwise the same number of turns recorded during disassembly. Take dimension "A" and "B" measurements. Make remaining minor adjustments to bring dimensions into tolerances of Table 1. (Ref. "INSTALLATION" section).**

6. Assemble and re-install trolley as described in the applicable trolley "INSTALLATION" section.
7. Conduct trolley operational test as described in "OPERATION" section of this manual. Trolley must operate safely and smoothly prior to being placed in service for general use.

## 10 ton Trolley Hanging Plate Disassembly

This section details the disassembly of the 10 ton trolley hanging plate sub-assembly.

### CAUTION

• **Observe proper safety precautions when conducting maintenance on or around trolleys. It is recommended that trolley be removed from beam and moved to a safe work area.**

1. Remove capscrews (35), keys (34) and suspension shaft (33).

### NOTICE

• **Record the number of spacers (26) between hanging plates (31) and side plates (11 or 21), and on the outside of side plates (11) for use during re-installation.**

2. Remove nuts (24), washers (25) and spacers (26) from shaft (27).
3. Remove side plates (11) by sliding along shaft (27) until clear.
4. Remove spacers (26) from shafts (27).
5. Remove hanging plate (31) by sliding off shafts (27).
6. Remove collars (32).
7. Remove hanging plate (31) by sliding off shafts (27).
8. Remove spacers (26) from shafts (27).
9. Remove shafts (27) from side plates (11 or 21) by disassembly of capscrews (29) and nuts (38).
10. Assemble and re-install trolley as described in the applicable trolley "INSTALLATION" section.

### NOTICE

• **During reassembly install spacers (26) between hanging plates (31) and side plates (11 or 21) and on the outside of side plates (11) in same configuration as noted in disassembly or as directed by Table 2 of the "INSTALLATION" section.**

11. Conduct trolley operational test as described in "OPERATION" section of this manual. Trolley must operate safely and smoothly prior to being placed in service for general use.

## 1/2 to 10 ton Trolley Wheel Repair

This section details disassembly of the wheel assembly from the side plate and includes procedures for bearing removal, inspection of the wheel-bearing housing, bearing installation and wheel to trolley assembly.

1. To repair or replace geared (13) or plain (1) wheels, remove retainer ring (4) from side plate (7, 11 or 21) wheel shaft.
2. Remove wheel assembly from sideplate. If wheel assembly is stuck to side plate wheel shaft, gently tap wheel and wheel shaft with a soft mallet to loosen. For wheels difficult to remove, use a gear puller.
3. To replace wheel bearing (2), press or pull the bearing from the back of the trolley wheel (1 or 13). When removed, clean wheel shaft and bearing housing area. Inspect for abnormal wear or damage. Repair or replace wheel as required. Prior to reassembly lightly coat shaft and bearing housing areas with applicable lubricant.
4. To install wheel bearing (2), press bearing into the back of the wheel.

### NOTICE

• **Press only on the outer race of the bearing. Press evenly to ensure bearing does not misalign, jam or become damaged during installation.**

5. Install plain (1) or geared (13) wheel assembly on side plate (7, 11 or 21) wheel shaft and secure with retainer ring (4). During assembly coat wheel shaft with an applicable lubricant to prevent corrosion.
6. Re-install trolley as described in the applicable trolley "INSTALLATION" section.

### NOTICE

• **To re-install 1/2 to 5 ton trolley suspender shaft (5) in side plate (7) and suspender (6) on suspender shaft turn clockwise the same number of turns recorded during disassembly. Take dimension "A" and "B" measurements. Make remaining minor adjustments to bring dimensions into tolerances of Table 1 in "INSTALLATION" section.**

• **During reinstallation of 10 ton trolley install spacers (26) between hanging plates (31) and side plates (11 or 21) and on the outside of side plates (11) in same configuration as noted in disassembly or as directed by Table 2 of the "INSTALLATION" section.**

7. Conduct trolley operational test as described in "OPERATION" section of this manual. Trolley must operate safely and smoothly prior to being placed in service for general use.

1 to 5 ton Geared Trolley

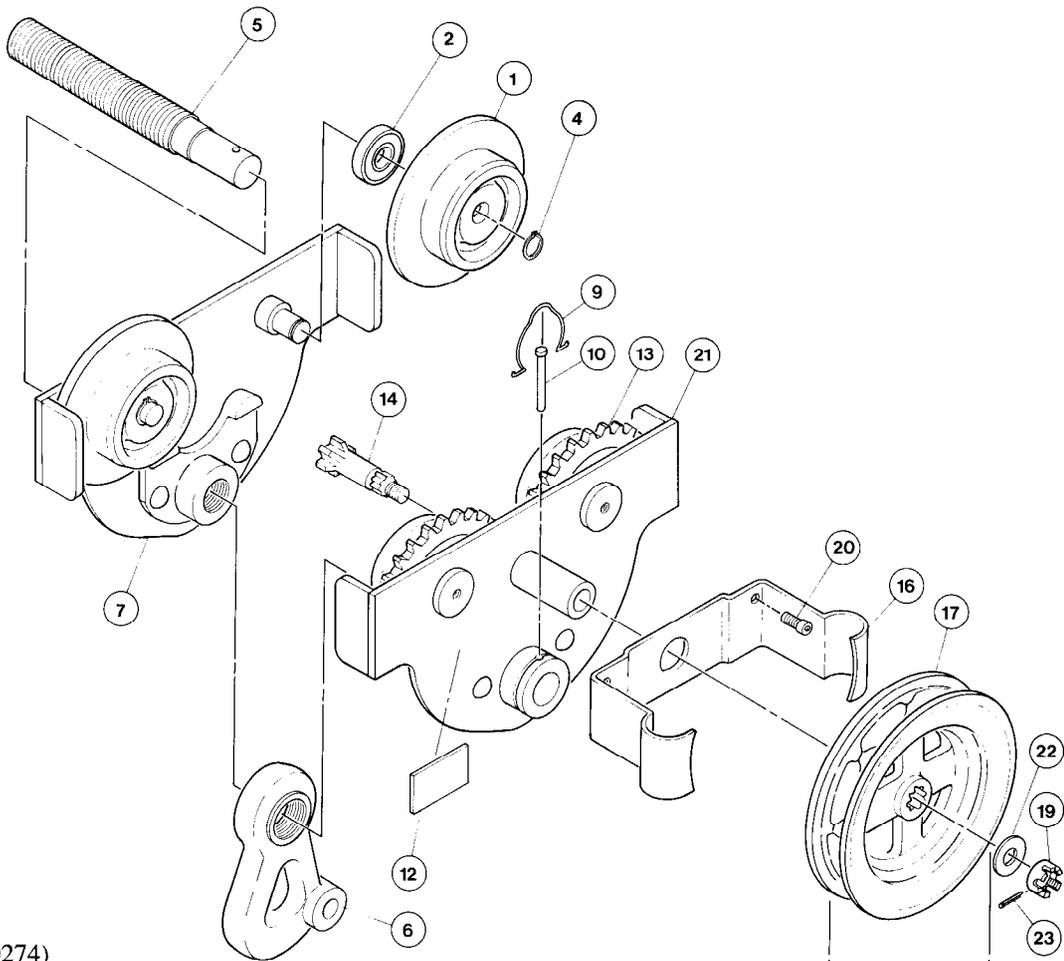

(Dwg. MHTPA0274)

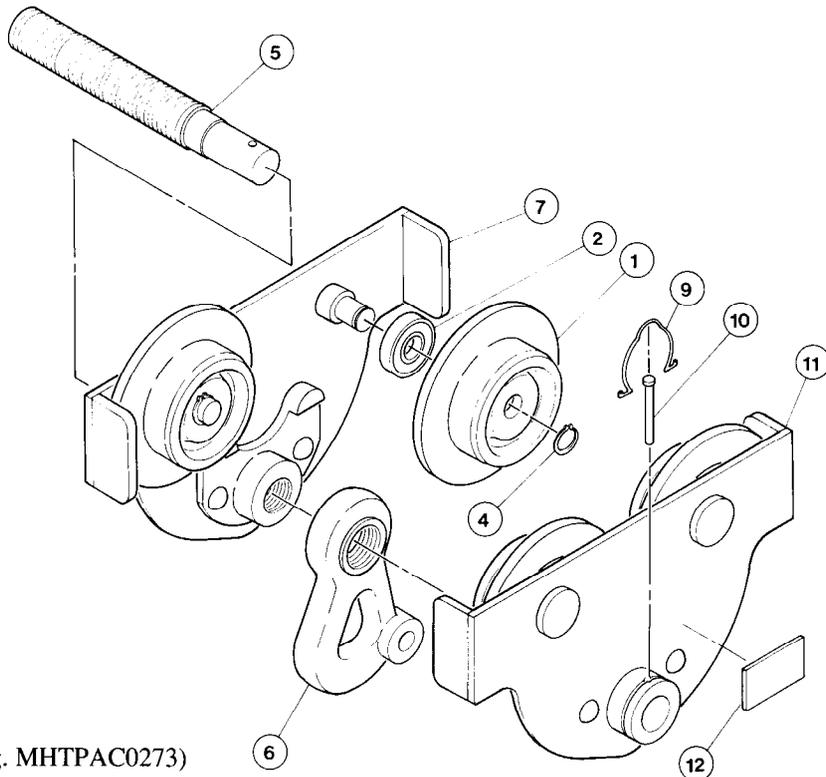

(Dwg. MHTPAC0273)

1/2 to 5 ton Plain Trolley

## 1/2 TO 5 METRIC TON PLAIN AND GEARED TROLLEY PARTS LIST

ITEM NO.	PART DESCRIPTION	QTY. TOTAL	PART NUMBER				
			1/2 ton	1 ton	2 ton	3 ton	5 ton
1	Wheel (Plain)	*	71113443	71113450	71113468	71113476	71113484
● 2	Bearing	4	71113492	71113500	71113518	71113526	71113534
● 4	Retainer Ring	4	71113542	71113559	71113567	71113575	71113583
5	Suspender Shaft	1	71113591		71113609	71113617	71113625
6	Suspender	1	71113633		71113658	71113666	71113674
7	Side Plate (Threaded)	**	Not sold separately				
● 9	Pin Retainer	1	71113732		71113740	71113757	71113765
10	Shaft Stopper Pin	1	71113773		71113781	71113799	71113807
11	Side Plate (Plain)	**	Not sold separately				
12	Capacity Label (Plain)	1	71084313	71084305	71084321	71084347	71084362
	Capacity Label (Geared)		---	71084297	71084339	71084354	71084370
	Trolley Warning Label		71107130				
13	Wheel (Geared)	*	---	71113864	71113872	71113880	71113898
14	Pinion Shaft	1	---	71113906		71113922	
16	Chain Guide	1	---	71113963	71113971	71113989	
17	Hand Wheel	1	---	71113997	71114003	71114011	
18	Hand Chain	1	---	HCCB005	HCCV020		
19	Nut	1	---	71114029			
20	Capscrew	2	---	71114045			
21	Side Plate (Geared)	**	---	Not sold separately			
22	Washer	1	---	71114110			
● 23	Split Pin	1	---	71114128			

● Recommended Spare

### Quantity Required:

- \* Plain Trolley - 4 Plain Wheels (1).
- \* Geared Trolley - 2 Plain Wheels (1) & 2 Geared Wheels (13).
- \*\* Plain Trolley - 1 Plain Side Plate (11) & 1 Threaded Side Plate (7).
- \*\* Geared Trolley - 1 Threaded Side Plate (7) & 1 Geared Side Plate (21).

## ACCESSORIES

DESCRIPTION OF ACCESSORY	ACCESSORY PART NUMBER
Lubricant	Lubri-Link
Touch-up Paint	MHD-OR

# 10 METRIC TON GEARED TROLLEY ASSEMBLY DRAWING

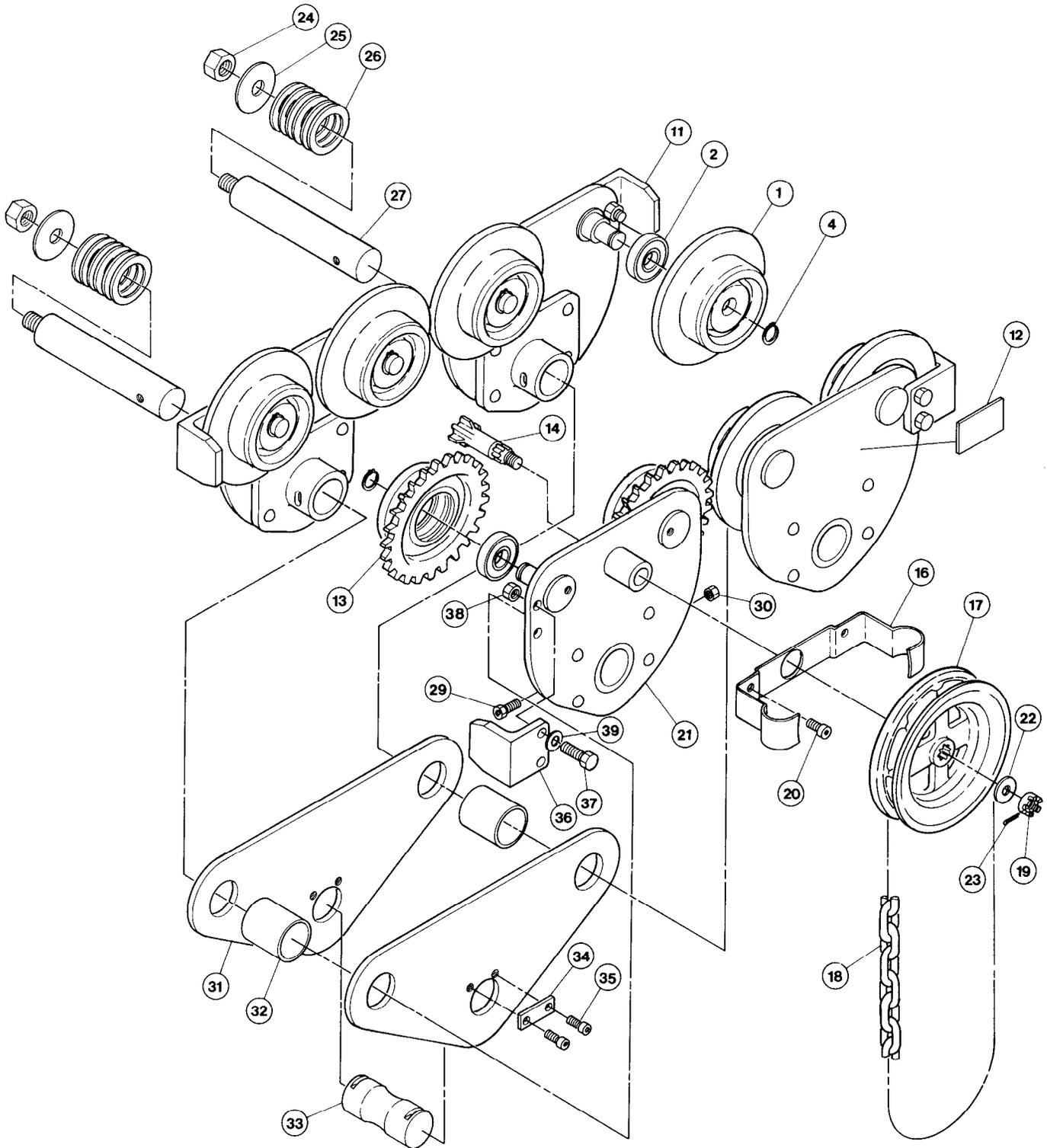

(Dwg. MHTPC0275)

## 10 METRIC TON PLAIN AND GEARED TROLLEY PARTS LIST

ITEM NO.	PART DESCRIPTION	QTY. TOTAL	PART NUMBER
1	Wheel (Plain)	*	71113484
		8	71113534
		6	71113583
11	Side Plate (Plain)	**	Not sold seperately
12	Capacity Label (Plain)	1	71084388
	Capacity Label (Geared)		71084396
	Trolley Warning Label		71107130
13	Wheel (Geared)	2	71113898
14	Pinion Shaft	1	71113922
16	Chain Guide	1	71113989
17	Hand Wheel	1	71114011
18	Hand Chain	1	HCCV020
19	Nut	1	71114029
20	Capscrew	2	71114045
21	Side Plate (Geared)	1	Not sold seperately
22	Washer	1	71114110
		1	71114128
24	Nut	2	71114136
25	Washer	2	71114144
26	Spacer	16	71114151
27	Shaft	2	71114169
29	Capscrew	2	71114177
30	Nut	8	71114243
31	Hanging Plate	2	71114185
32	Collar	2	71114193
33	Suspender Pin	1	71114201
34	Key	2	71114219
35	Capscrew	4	71114227
36	Drop Stop	4	71114235
37	Capscrew	8	71109110
38	Nut	2	71114243
39	Washer	8	71114250

 Recommended Spare

\* Quantity Required: Plain Trolley - 8 / Geared Trolley - 6.

\*\* Quantity Required: Plain Trolley - 4 / Geared Trolley - 3.

## PARTS ORDERING INFORMATION

The use of replacement parts other than **INGERSOLL-RAND Material Handling** will invalidate the Company's warranty. For prompt service and genuine **INGERSOLL-RAND Material Handling** parts, provide your nearest Distributor with the following:

1. Complete trolley model number and serial number as it appears on the nameplate.
2. Part number and part description as shown in this manual.
3. Quantity required.

### Return Goods Policy

**Ingersoll-Rand** will not accept any returned goods for warranty or service work unless prior arrangements have been made and written authorization has been provided from the location where the goods were purchased.

### NOTICE

• If your trolley has special finish requirements for painted parts, please specify when ordering replacement parts.

• Continuing improvement and advancement of design may cause changes to this trolley which are not included in this manual. Manuals are periodically revised to incorporate changes. Always check the manual edition number on the front cover for the latest issue.

### NOTICE

• When the life of the trolley has expired, it is recommended that the trolley be disassembled, degreased and parts separated as to materials so that they may be recycled.

For additional information contact:

#### Ingersoll-Rand Material Handling

P.O. Box 24046  
2724 Sixth Avenue South  
Seattle, WA 98124-0046  
Phone: (206) 624-0466  
Fax: (206) 624-6265

or

#### Ingersoll-Rand Material Handling Samiia, Douai Operations

111, avenue Roger Salengro  
59450 SIN LE NOBLE, France  
Phone: (33) 27-87-11-11  
Fax: (22) 27-96-03-29

## TROLLEY LABEL PLATE

### NOTICE

• Trolley capacity label located on side plate.

Each trolley is supplied from the factory with the label shown. If the label is not attached to your unit, order a new label and install it. See the parts list for the part number. Label may not be shown actual size.



## HOIST AND WINCH LIMITED WARRANTY

**Ingersoll-Rand Company (I-R)** warrants to the original user its Hoists and Winches (Products) to be free of defects in material and workmanship for a period of one year from the date of purchase. I-R will repair, without cost, any Product found to be defective, including parts and labor charges, or at its option, will replace such Products or refund the purchase price less a reasonable allowance for depreciation, in exchange for the Product. Repairs or replacements are warranted for the remainder of the original warranty period.

If any Product proves defective within its original one year warranty period, it should be returned to any Authorized Hoist and Winch Service Distributor, transportation prepaid with proof of purchase or warranty card.

This warranty does not apply to Products which I-R has determined to have been misused or abused, improperly maintained by the user, or where the malfunction or defect can be attributed to the use of non-genuine I-R parts.

**I-R makes no other warranty, and all implied warranties including any warranty of merchantability or fitness for a particular purpose are limited to the duration of the expressed warranty period as set forth above. I-R's maximum liability is limited to the purchase price of the Product and in no event shall I-R be liable for any consequential, indirect, incidental, or special damages of any nature rising from the sale or use of the Product, whether based on contract, tort, or otherwise.**

**Note:** Some states do not allow limitations on incidental or consequential damages or how long an implied warranty lasts so that the above limitations may not apply to you.

This warranty gives you specific legal rights and you may also have other rights which may vary from state to state.

## IMPORTANT NOTICE

It is our policy to promote safe delivery of all orders.

This shipment has been thoroughly checked, packed and inspected before leaving our plant and receipt for it in good condition has been received from the carrier. Any loss or damage which occurs to this shipment while enroute is not due to any action or conduct of the manufacturer.

### **VISIBLE LOSS OR DAMAGE**

If any of the goods called for on the bill of lading or express receipt are damaged or the quantity is short, do not accept them until the freight or express agent makes an appropriate notation on your freight bill or express receipt.

### **CONCEALED LOSS OR DAMAGE**

When a shipment has been delivered to you in apparent good condition, but upon opening the crate or container, loss or damage has taken place while in transit, notify the carrier's agent immediately.

### **DAMAGE CLAIMS**

You must file claims for damage with the carrier. It is the transportation company's responsibility to reimburse you for repair or replacement of goods damaged in shipment. Claims for loss or damage in shipment must not be deducted from the Ingersoll-Rand invoice, nor should payment of Ingersoll-Rand invoice be withheld awaiting adjustment of such claims as the carrier guarantees safe delivery.

You may return products damaged in shipment to us for repair, which services will be for your account and form your basis for claim against the carrier.

## United States Office Locations

### For Order Entry and Order Status:

**Ingersoll-Rand  
Distribution Center**  
P.O. Box 618  
510 Hester Drive  
White House, TN 37188  
Phone: (615) 672-0321  
Telex: 786573  
Fax: (615) 672-0801

**Ingersoll-Rand  
Material Handling  
Technical Support**  
P.O. Box 24046  
2724 Sixth Avenue South  
Seattle, WA 98124-0046  
Phone: (206) 624-0466  
Telex: 328795  
Fax: (206) 624-6265

### Regional Sales Offices:

**Atlanta, GA**  
111 Ingersoll-Rand Drive  
Chamblee, GA 30341  
Phone: (404) 936-6230

**Detroit, MI**  
23192 Commerce Drive  
Farmington Hills, MI 48335  
Phone: (313) 476-6677  
Fax: (313) 476-6670

**Houston, TX**  
Suite 150  
2500 East T.C. Jester  
Houston, TX 77008  
Phone: (713) 864-3700

**Los Angeles, CA**  
5533 East Olympic Blvd.  
Los Angeles, CA 90022  
Phone: (213) 725-2826

**Milwaukee, WI**  
12311 W. Silver Spring Dr.  
Milwaukee, WI 53225  
Phone: (414) 461-0973

**Philadelphia, PA**  
P.O. Box 425  
900 E. 8th Ave., Suite 103  
King of Prussia, PA 19406  
Phone: (215) 337-5930

## International Office Locations

Offices and distributors in principal cities throughout the world. Contact the nearest Ingersoll-Rand office for the name and address of the distributor in your country or write/fax to:

**Ingersoll-Rand  
Material Handling**  
P.O. Box 24046  
2724 Sixth Avenue South  
Seattle, WA 98124-0046  
USA  
Phone: (206) 624-0466  
Telex: 328795  
Fax: (206) 624-6265

**Canada:  
National Sales Office  
Regional Warehouse  
Toronto, Ontario**  
51 Worcester Road  
Rexdale, Ontario  
M9W 4K2  
Phone: (416) 675-5611  
Fax: (416) 675-6920

### Regional Sales Offices

**Calgary, Alberta**  
333 11th Avenue S.W.  
Calgary, Alberta  
T2R 0C7  
Phone: (403) 261-8652

**Montreal, Quebec**  
3501 St. Charles Blvd.  
Kirkland, Quebec  
H9H 4S3  
Phone: (514) 695-9040

**British Columbia**  
201-6351 Westminster Hwy  
Richmond, B.C.  
V7C 5C7  
Phone: (604) 278-0459

**British Columbia  
Regional Warehouse  
Technical Support**  
123 Bowser Avenue  
North Vancouver, British  
Columbia V7P 3H1  
Phone: (604) 985-4470  
Fax: (604) 985-0160

**Latin America Operations  
Ingersoll-Rand  
Production Equipment  
Group**  
730 N.W. 107 Avenue  
Suite 300, Miami, FL  
33172-3107  
Phone: (305) 559-0500  
Telex: 441617TLS UI  
Fax: (305) 559-7505

**Europe, Middle East and  
Africa  
Ingersoll-Rand  
Material Handling  
Samiia, Douai Operations**  
111, avenue Roger Salengro  
59450 SIN LE NOBLE,  
France  
Phone: (33) 27-87-11-11  
Fax: (22) 27-96-03-29