

Form MHD56029
Edition 2
April 1990
71056584

PARTS LIST
for
K5B-546 and K5B-550
AIR MOTORS

Refer All Communications to the Nearest
Ingersoll-Rand Material Handling Products
Office or Distributor.

© *Ingersoll-Rand Company 1990*

INGERSOLL-RAND®

MATERIAL HANDLING

K5B-546 and K5B-550 AIR MOTORS

DESCRIPTION

The K5B-546 and K5B-550 air motors are reciprocating, radial 5 piston motors that use compressed air for a power source up to 110 psig maximum (7.5 bar). They have infinite variable speeds, develop maximum torque at low RPM and can be stalled-started-stopped and reversed without damage. Air motor performance characteristics can be preset to a maximum level with a commercial adjustable pressure regulator and controlled with a spring loaded manual throttle valve. The throttle can be ordered mounted on the motor or as a separate remotely mounted universal type valve used for remote control operation.

Lubrication

CAUTION

The motors are shipped less oil and must be refilled prior to operation of the motor. Shut off air supply and add 4 oz. (1/4 cup) motor oil to air hose before running motor. Air supply to the motor must be filtered and lubricated at all times or damage to the motor will result.

Filling the motor with oil:

1. Motors are shipped with cans of I-R motor oil, or the following oil can be substituted.
below 32° F (0° C): SAE 10 W or Dextron AFT
32° F to 80° F (26° C): SAE 20 W or Dextron ATF
above 80° F (26° C): SAE 30 W or Dextron ATF
(Motors use approximately 64 oz.)
2. Maintain motor in a horizontal position.
3. Remove oil fill/vent cap (11) and oil level plug (4).
4. While pouring oil through the fill hole (11) SLOWLY rotate the motor less than 50 RPM.
5. Motor case is full when oil starts flowing out of level hole (4).
6. Reinstall level plug (4) and fill/vent cap (11).

Oil Level Checks

Check oil levels at the following conditions:

1. At temperatures above 32° F (0° C): after the motor has been off for several hours or overnight, loosen the drain plug (2) located at the bottom of motor case and allow the accumulated water to drain out.
2. At temperatures below 32° F (0° C): allow the motor to remain off long enough for the water to separate from the oil but not long enough for it to freeze. The actual ambient air temperatures and oil temperature after shut-down will determine how long this will take. Drain the water and replenish oil as above.

Should this procedure be impractical, drain the entire contents from the motor case immediately after motor operation ceases.

NOTICE

The motor may need to be cranked over slowly (less than 50 RPM) a few revolutions to push the oil out of the lower two cylinders.

CAUTION

If motor will not be refilled at this time, tag the motor and throttle so it will not be used prior to refilling or motor damage will result.

NOTICE

If motor case is not drained in temperatures below freezing, water may eventually accumulate and cause the motor to freeze tight.

3. After every eight (8) hours of operation inject two or three pumps of #2 cup grease from a hand grease gun into fittings (38) and (49).

Air Supply Lines

Air motors require approximately 30 cfm of free air at 100 psig (6.8 bar) to generate one (1) horsepower. The K5B-546 will require approximately 720 cfm for continuous operation at maximum horsepower. To achieve this performance an air line of 2" (51mm) or greater in diameter should be used. The supply air must be clean, free of water moisture and oil lubricated. Therefore the air supply system must include an inlet filter of 20 micron filtration, a moisture trap and a line oiler. The air line oiler should deliver 10-15 drops per minute of SAE 10 W oil or Dextron ATF transmission fluid.

NOTICE

The air line oiler is not a substitute for the motor case oil described in the lubrication section. Ensure there is enough oil in the lubricator prior to each use for proper rotary valve lubrication.

Installation

General Information

The motor must be mounted in a horizontal position with the throttle handle straight up. If the motor is to be mounted at an angle of 10° or more off of horizontal, poor internal lubrication will result. Consult the factory for special instructions.

Flange mounted motors can be mounted in either of the following two methods.

Method 1. Provide a mounting with a close fit on the 13 3/8" (339.7mm) reference pilot diameter on the mounting flange cover (64). Fasten with the ten capscrews, washers and nuts (67, 68, and 69).

Method 2. Use the 16 1/8" (409.6mm) reference outside diameter of the mounting flange cover (64). Fasten with the ten capscrews, washers and nuts (67, 68 and 69).

For either method, the following general information applies:

1. It is necessary to provide a bearing for the outer end of the motor shaft pinion or shaft extension. Locate it as far from the motor as practical and be certain that it is properly aligned.
2. Do not make shaft extensions a tight fit in the broached spline of the crank. An outboard bearing cannot be perfectly aligned with the crank bearings and, therefore, the splined fit must serve to a limited extent as a flexible coupling.
3. The motor shaft must be supported in such a manner that no end thrust will be transferred to the crank.
4. Consult the factory if more detail is needed.

Motor Disassembly

Refer to drawing number P90G1012 for parts location

WARNING

Shut off, bleed down and disconnect the air supply line before performing any disassembly procedures.

1. Drain the motor oil from the motor case by removing drain plug (2).

WARNING

Motor weighs approximately 260 pounds (118 kgs). Provide adequate support before removing mounting capscrews.

2. Remove ten mounting capscrews (67).
3. Remove the five capscrews (39) from the exhaust flange. Do not remove the two capscrews (45) from the throttle valve housing (47).
4. Remove the rotary valve housing (36) by pulling it out of the motor housing (1) as an assembly with the exhaust flange.

CAUTION

Do not remove the exhaust flange until the rotary valve (40) has been removed from the valve chest.

5. Remove rotary valve (40) by pulling it out from the assembly through the motor housing end of the rotary valve housing.
6. Remove exhaust flange (44) and throttle valve (47) by removing capscrews (45) and (52), respectively.
7. Remove each cylinder head by removing the four capscrews (35). Remove head gasket (34).
8. Remove mounting flange (64) by removing fasteners (67), (68) and (69) and then pulling mounting flange straight off.
9. Pull the cylinder (33) straight out.
10. Position the piston (27) at the top of its stroke. In this position, with the cylinder pulled out in step 9, the wrist pin (30) can be removed. For K5B-546 motors remove one pin retainer (31) from either side of piston. Push the wrist pin out by hand from one side. If the wrist pin is too tight it is allowable to carefully heat the piston to 200° F (93° C) or less and then push the pin out.

NOTICE

If piston, wrist pin, rod or cylinder are to be re-assembled, number each set. Also add radial alignment marks for each piston and cylinder to the motor case.

11. Remove the other four cylinders and pistons as in steps 9 and 10.
12. Crank shaft assembly (16) can now be removed with the oil slinger (17) by pulling straight out from the motor housing. Use care while guiding the connecting rods (23) through the inside of the motor housing.

Crankshaft Disassembly

1. Remove cotter pin (21) and the taper pin nut (20).
2. Remove lock pin (19) by carefully driving it out of its location. Use care not to damage the threads.
3. Pull the crankshaft valve end (16A) off the crankshaft (16B).
4. Remove rings (24), bushings (25 and 26) and connecting rods (23). Record number and direction of foot for the five rods (23) so they can be installed in the same order.
5. Oil slinger (17) does not have to be removed unless damaged. If removal is required heating of the five screws (18) may be required to loosen the loc-tite connection.

Throttle Valve Disassembly

NOTICE

Match mark throttle valve parts to ensure proper reassembly.

1. Remove two capscrews (not shown) that hold the valve body retainer (56A).
2. The throttle handle (58) may remain assembled to the valve (55) unless parts are damaged.
3. Make note on how the throttle spring (59) is positioned before removing it. Pull valve (55) out of the valve bushing (54) while disconnecting the throttle spring.
4. Check parts for score marks or wear. Clearance between the valve bushing and valve should not exceed .002" (.05mm) or excessive air leakage will occur.

Motor Assembly

General instructions

- use all new gaskets and seals
- replace worn parts
- lubricate all parts with a mixture of half SAE 20 W oil and half STP
- refer to assembly drawing number P90G1012 for parts location.

1. For throttle valve assembly, install both seal rings (56) on the valve body (55). Install valve body into the valve housing (47).
2. Install valve body retainer (56A) with two capscrews (56B) and torque to 25 ft-lbs (3.5 kg.m).
3. If spring stud (60) was removed during disassembly, reinstall and torque to 25 ft-lbs (3.5 kg.m).
4. Install spring (59) and handle (58) on square shaft of valve body (55) taking note of the match marks put on during disassembly. The ends of the spring (59) must straddle the studs (60) on throttle handle. Install roll pin (61).
5. Assemble throttle assembly, gasket (51) and exhaust flange (44) to rotary valve housing (36) using four capscrews (52). Install two capscrews (45) that attach exhaust flange (44) to throttle valve housing.
6. Tighten capscrews (45 and 52) to 25 ft-lbs (3.5 kg.m). Throttle handle should move freely left and right with no binding and should center from left or right by the spring force only.
7. Assemble bearing (41) to rear of rotary valve (40) by pressing only on the inner race of the bearing. To install seal ring (42) on the crank shaft end of the rotary valve (40). With the exhaust flange (44) down install rotary valve (40) into rotary valve housing (36).
9. Install O-ring seal (10) into motor housing (1).
10. Install the rotary valve housing gasket (37) onto rotary valve housing (36). With the exhaust flange down on the bench, install motor housing (1) on to rotary valve housing (36). Check for any evidence of damage to O-ring (10) when the rotary valve housing is fully engaged. Install and tighten capscrews (39) to 50 ft-lbs (7 kg.m).
11. If removed, press crankshaft bearing (22) on crankshaft with seals located as shown in the cross-section drawing. Apply pressure only on the inner race of the bearing.
12. Place crankshaft on a work bench with the oil splasher down and slide the sleeve (26) (with tang up) on the crankpin.
13. Slide bushing (25) over the sleeve (26) and first retaining ring (24) with the chamfer up.
14. Install the connecting rods (23) in the same order as removed, with all feet pointing in the same direction, using the first retaining ring (24) to hold one side of the connecting rod feet.
15. Slide the second retaining ring (24) over the other side of the connection rod feet with the chamfer on the ring facing down (toward the stem of the connecting rod).
16. Slide the crankshaft valve end (16A) over the crankpin while simultaneously aligning the tang on the sleeve (26) with the slot in the crankshaft.

17. Rotate and position the crankshaft valve end relative to the crankpin to allow installation of the lock pin (19).
18. Tap the pin (19) in place and install the nut (20). Tighten nut to 60 ft-lbs (8.3 kg.m) of torque.
19. Install cotter pin (21).
20. Install timing pin (43) and bearing (22) into the valve end of the crankshaft.
21. Check that all connecting rods move freely around the crank. Position the crankshaft assembly (16) into the motor housing (1) so the bearing (22) is seated and connecting rods (23) are centered in the cylinder holes.

NOTICE

Make certain that the timing pin (43) and the three lugs on the rotary valve (40) line up with the corresponding hole and lugs on the crankshaft.

NOTICE

Do not let the rotary valve (40) slide back in housing (36). If the rotary valve slides in too far, the ring (42) will lock-up in the internal grooves of the housing (36) causing further assembly to be impossible.

22. Rotate the crankshaft so one connecting rod is at the top of its stroke. Install a piston (27) with its rings (28 and 29) to the connecting rod with wrist pin (30) and retaining rings (31).
23. Install a new cylinder gasket (34) before installing the cylinder.
24. Install the cylinder (33) over the piston by compressing both piston rings (28 and 29) with a single band ring compressor.
25. Install cylinder head (32) over the cylinder and secure head to motor housing (1) with four cap-screws (35). Torque cap screws to 60 ft-lbs (8.3 kg.m).
26. Repeat Steps 14 through 17 with the remaining cylinders.
27. Rotate motor by hand. There should be no binding.
28. Install mounting flange (64) and gasket (66) on the front of the motor housing. Make sure notches on both parts are aligned.
29. Install ten capscrews (67) with nuts (68) and washers (69) finger tight to temporarily hold motor.
30. Add oil to the reservoir as described in the lubrication section. Run motor slowly with lubricated air at 100-200 RPM with no load to check for freeness of rotation.
31. Tighten all bolts and run motor for two (2) hours as a break-in period at 100-200 RPM.

AIR MOTOR TROUBLE SHOOTING GUIDE

This trouble-shooting table provides a basic guide to the cause and remedy of some of the more common troubles associated with radial air motors and air motor operation. Since it is impossible to anticipate all of the mechanical failures and operator errors that might occur, thorough trouble shooting depends on the skill of maintenance personnel.

TROUBLE	CAUSE	REMEDY
1. Motor will not start.	A. Low air pressure or insufficient cfm's. B. Starting load excessive. C. Oil slinger and/or lower piston frozen. D. One of the exhaust ports may be plugged.	Check air pressure and flow at inlet of the motor. Check load motor. Load should not exceed the rated load capacity. Thaw motor. Check both exhaust ports for any plug.
2. Motor loses power during operation.	A. Low air pressure or insufficient cfm's. B. Ice in exhaust port and/or air lines. C. Input air line damaged or foreign material in input or exhaust lines. D. Excessive load on motor. E. Improper lubrication.	Same as 1A. Check aftercoolers and traps. Add airline antifreeze to air supply. Check input air line for crimps, leakage, or other damage. Same as 1B. Check crankcase for proper oil level. Refill as required. See lubrication section.
3. Motor makes excessive noises during operation.	A. Foreign material in rotary valve or cylinder. B. Improper lubrication. C. Broken piston, connecting rod, or other rotating element.	Remove rotary valve housing end-plate and/or cylinder heads and check for foreign material. Same as 2E. Disassemble and repair motor.

K5B-546 and K5B-550 AIR MOTOR PARTS LIST

ITEM NO.	DESCRIPTION OF PART	QTY. TOTAL	PART NO. K5B-546	PART NO. K5B-550
1	Motor Housing	1	K5B-501	K5B-501
2	3/8" Pipe Plug	2	GA57-95	GA57-95
3	1/4" Pipe Plug	1	ROH-377	ROH-377
4	1/8" Pipe Plug	1	TC-368	TC-368
5	Eye Bolt	2	KU-888	KU-888
6	Cover Plate	1	K5B-1001	K5B-1001
7	Gasket	1	K5B-1002	K5B-1002
8	Capscrew	2	119A2A202	119A2A202
9	Lock Washer	2	D02-321	D02-321
10	O-ring	1	20A11CM248	20A11CM248
11	Vent Cap Assembly	2	K5B-A303	K5B-A303
12	Cotter Pin	1	D02-893	D02-893
13	Chain	1	D02-891	D02-891
14	S-Hook	1	D02-421	D02-421
15	Screen	1	K5B-889	K5B-889
*	Nameplate	1	K5B-301	K5B-301
*	Drive Screw	4	R4K-302	R4K-302
*	Caution Tag	1	K5B-113	K5B-113
16	Crank Assembly-includes 17-26 (components not sold separately)	1	K5B-A516	K5B-A516
17	Oil Slinger	1	K5B-540	K5B-540
18	Button Head Screw	5	K5B-541	K5B-541
19	Lock Pin	1	HU-520	HU-520
20	Pin Nut	1	D02-394	D02-394
21	Cotter Pin	1	D02-524	D02-524
22	Crank Bearing	2	K5B-518	K5B-518
23	Connecting Rod	5	K5B-509	K5B-509
24	Connecting Rod Ring	1	K5B-510	K5B-510
25	Connecting Rod Bushing	1	K5B-511	K5B-511
26	Sleeve	1	K5B-519	K5B-519
	Piston Assembly-includes items 27-31 (can be ordered separately)	1	K5B-A513-47	K5B-A513A-50
27	Piston	5	K5B-513-47	K5B-A513A-50
28	Compression Ring	5	K5B-337-47	KU-337
29	Oil Ring	5	K5B-338-47	KU-338
30	Wrist Pin	5	HU-514A	251A0223A
31	Retainer Ring	10	902A45-632	N/A

 Recommended spares

* Not Shown

N/A Not Applicable

K5B-546 and K5B-550 AIR MOTOR PARTS LIST

ITEM NO.	DESCRIPTION OF PART	QTY. TOTAL	PART NO. K5B-546	PART NO. K5B-550
	Cylinder Assembly-includes items 32 & 33 (can be ordered separately)	1	K5B-A505-47	251P2830A
32	Cylinder Head	5	K5B-H505	N/A
33	Cylinder Liner	5	K5B-L505-47	N/A
34	Head Gasket	5	K5B-507	K5B-507
35	Capscrew	20	119A2A251	119A2A251
36	Rotary Valve Housing	1	K5B-545	K5B-545
37	Gasket	2	K5B-928	K5B-928
38	Grease Fitting	1	23-188	23-188
39	Capscrew	5	119A2A267	119A2A267
40	Rotary Valve	1	K5B-526	K5B-526
41	Bearing	1	K5B-97	K5B-97
42	Seal Ring	1	K5B-607	K5B-607
43	Roll Pin	1	WF171-15	WF171-15
44	Exhaust Flange	1	K5B-276	K5B-276
45	Capscrew	2	119A2A200	119A2A200
46	Lock Washer	2	D02-321	D02-321
47	Throttle Valve Housing	1	K5B-1101	K5B-1101
48	Pipe Plug	2	E5UD-947	E5UD-947
49	Grease Fitting	1	23-188	23-188
50	Roll Pin	1	25A13C92	25A13C92
51	Gasket	1	K5B-547	K5B-547
52	Capscrew	4	119A2A202	119A2A202
53	Lock Washer	4	D02-321	D02-321
54	Throttle Valve Bushing	1	K5B-945	K5B-945
55	Valve Body	1	K5B-944	K5B-944
56	Seal Ring	2	K5B-606	K5B-606
56A*	Valve Body Retainer	1	K5B-1110	K5B-1110
56B*	Capscrew	2	119A2A198	119A2A198
57	Lock Screw	2	D02-321	D02-321
58	Handle	1	K5B-556	K5B-556
59	Throttle Spring	1	K5B-412	K5B-412
60	Spring Retaining Stud	1	K5B-553	K5B-553
61	Roll Pin	1	K5B-1115	K5B-1115
62	Latch	1	K5B-869	K5B-869
63	Roll Pin	1	HLK-20	HLK-20
64	Mounting Flange	1	K5B-502	K5B-502
65	Oil Seal	1	K5B-270	K5B-270
66	Gasket	1	K5B-592	K5B-592

Recommended spares

* Not Shown

N/A Not Applicable

K5B-546 and K5B-550 AIR MOTOR PARTS LIST

ITEM NO.	DESCRIPTION OF PART	QTY. TOTAL	PART NO. K5B-546	PART NO. K5B-550
67	Capscrew	10	119A2A254	119A2A254
68	Nut	10	215-182	215-182
69	Lock Washer	10	D10-322	D10-322
70	3/8" Pipe Plug	1	GA57-95	GA57-95
73	Flat Head Screw	1	139A2A266	139A2A266

Reference drawing **P90G1012**

 Recommended spares

* Not Shown

N/A Not Applicable

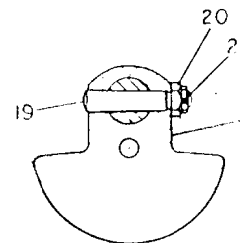
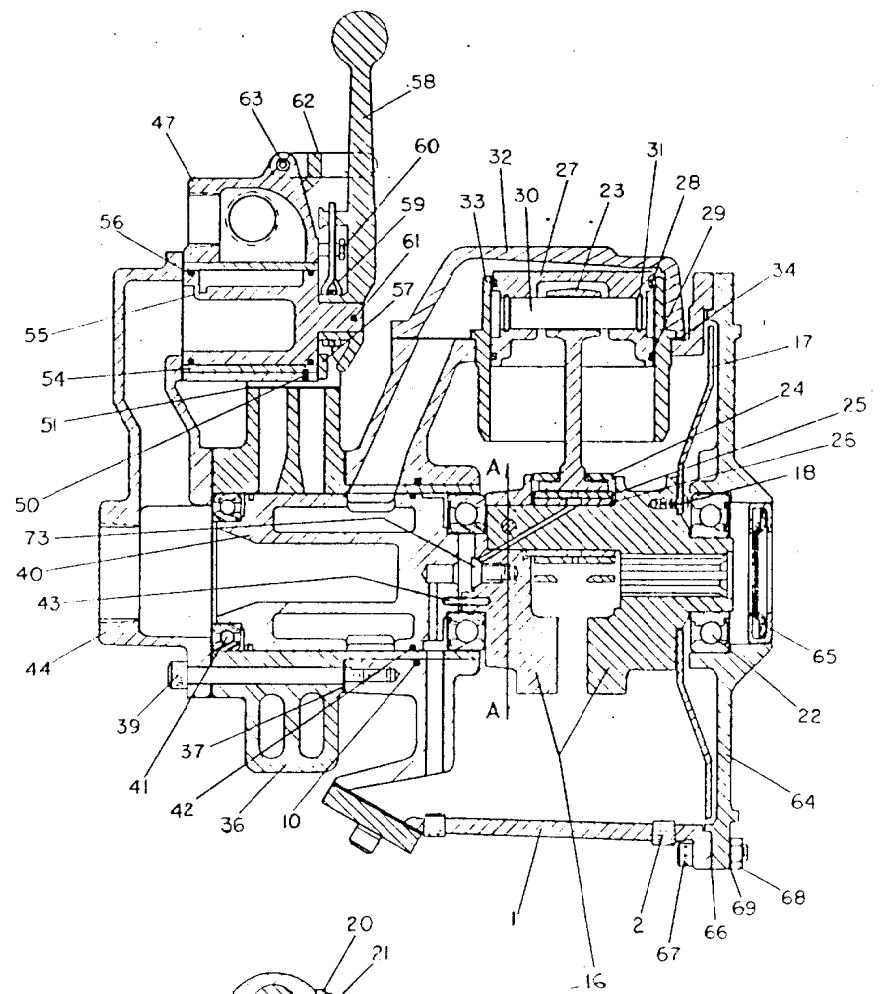
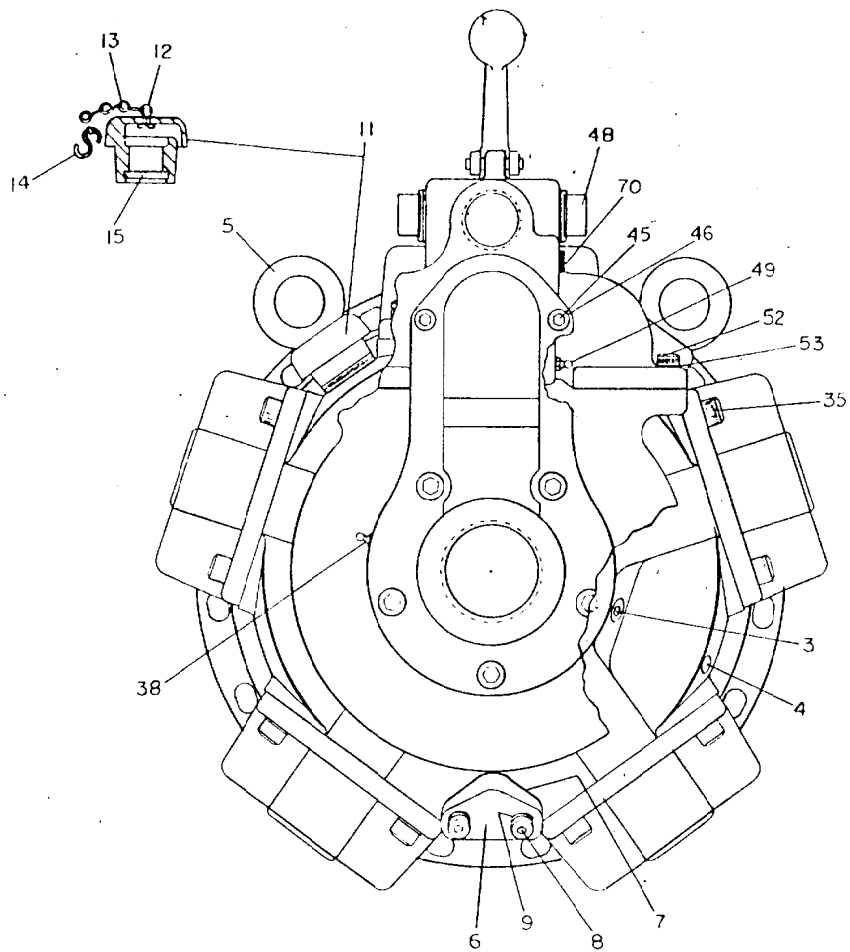

SEC. AA

INGERSOLL-RAND	
Title	Motor Assembly
Drawing No.	P90G1012

NOTES

NOTES

HOIST AND WINCH LIMITED WARRANTY

Ingersoll-Rand Company (I-R) warrants to the original user its Hoists and Winches (Products) to be free of defects in material and workmanship for a period of one year from the date of purchase. I-R will repair, without cost, any Product found to be defective, including parts and labor charges, or at its option, will replace such Products or refund the purchase price less a reasonable allowance for depreciation, in exchange for the Product. Repairs or replacements are warranted for the remainder of the original warranty period.

If any Product proves defective within its original one year warranty period, it should be returned to any Authorized Hoist and Winch Service Distributor, transportation prepaid with proof of purchase or warranty card.

This warranty does not apply to Products which I-R has determined to have been misused or abused, improperly maintained by the user, or where the malfunction or defect can be attributed to the use of non-genuine I-R parts.

I-R makes no other warranty, and all implied warranties including any warranty of merchantability or fitness for a particular purpose are limited to the duration of the expressed warranty period as set forth above. I-R's maximum liability is limited to the purchase price of the Product and in no event shall I-R be liable for any consequential, indirect, incidental, or special damages of any nature rising from the sale or use of the Product, whether based on contract, tort, or otherwise.

Note: Some states do not allow limitations on incidental or consequential damages or how long an implied warranty lasts so that the above limitations may not apply to you.

This warranty gives you specific legal rights and you may also have other rights which may vary from state to state.

IMPORTANT NOTICE

It is our policy to promote safe delivery of all orders.

This shipment has been thoroughly checked, packed and inspected before leaving our plant and receipt for it in good condition has been received from the carrier. Any loss or damage which occurs to this shipment while enroute is not due to any action or conduct of the manufacturer.

VISIBLE LOSS OR DAMAGE

If any of the goods called for on the bill of lading or express receipt are damaged or the quantity is short, do not accept them until the freight or express agent makes an appropriate notation on your freight bill or express receipt.

CONCEALED LOSS OR DAMAGE

When a shipment has been delivered to you in

apparent good condition, but upon opening the crate or container, loss or damage has taken place while in transit, notify the carrier's agent immediately.

DAMAGE CLAIMS

You must file claims for damage with the carrier. It is the transportation company's responsibility to reimburse you for repair or replacement of goods damaged in shipment. Claims for loss or damage in shipment must not be deducted from the Ingersoll-Rand invoice, nor should payment of Ingersoll-Rand invoice be withheld awaiting adjustment of such claims as the carrier guarantees safe delivery. You may return products damaged in shipment to us for repair, which services will be for your account and form your basis for claim against the carrier.

INGERSOLL-RAND Material Handling Division
2724 Sixth Avenue South, Seattle, Washington, USA 98134-2102
P.O. Box 24046, Seattle, Washington, USA 98124-0046
Phone (206) 624-0466, Telex: 3723554
Fax (206) 447-0715

INGERSOLL-RAND
MATERIAL HANDLING PRODUCTS
2724 SIXTH AVENUE SOUTH, SEATTLE, WASHINGTON 98134-2102
PHONE (206) 624-0466, TELEX: 3723554, TELEFAX: (206) 447 0715
P.O. BOX 24046, SEATTLE, WASHINGTON 98124-0046